

<b>GENERAL INDEX</b>	PAGES FOR REFER
	050 ~ 391











**PRODUCT INFORMATION**

	BALL BEARINGS	050 ~ 076
	TAPER ROLLER BEARINGS	078 ~ 089
	SPHERICAL ROLLER BEARINGS	092 ~ 117
	NEEDLE ROLLER BEARINGS	121 ~ 273
	LINEAR BALL BEARINGS	284 ~ 303
	TRACK ROLLER BEARINGS	317 ~ 327
	ROD ENDS	334 ~ 343
	BEARING UNITS	376 ~ 391
	TERMS & CONDITIONS	TC 1 - TC 6
	PACKING METHOD	PM 1 - PM 17
	MARKING IN WORKSHOP	MW 1 - MW 10



<h1>BALL BEARINGS</h1>	PAGES FOR REFER
	050 ~ 076

**BALL BEARINGS**

	60.., 60..LLB, 60..ZZ SERIES	050 ~ 051
	62.., 62..LLB, 62..ZZ SERIES	052 ~ 053
	63.., 63..LLB, 63..ZZ SERIES	054 ~ 055
	160.. SERIES	056
	68.., 68..LLB, 68..ZZ SERIES	057 ~ 058
	69.., 69..LLB, 69..ZZ SERIES	059 ~ 060
	622.., 622..2RS SERIES	061
	623.., 623..2RS SERIES	062
	630.., 630..2RS SERIES	063
	64.. SERIES	064

**DOUBLE-ROW ANGULAR CONTACT BALL BEARINGS**







	52.., 52..2RS SERIES	065 ~ 066
	53.., 53..2RS SERIES	067 ~ 068









**SELF-ALIGNING BALL BEARINGS**

















	12.., 12..K SERIES	069
	13.., 13..K SERIES	070
	22.., 22..K, 22..2RS SERIES	071 ~ 072
	23.., 23..K, 23..2RS SERIES	073 ~ 074

**STAINLESS STEEL BALL BEARINGS**

	S 60.. 2RS SERIES	075
	S 62.. 2RS SERIES	076

TAPER ROLLER BEARING		PAGES FOR REFER
		078 ~ 089
	302 SERIES	078 ~ 079
	303 SERIES	080 ~ 081
	320 SERIES	082 ~ 083
	322 SERIES	084 ~ 085
	323 SERIES	086 ~ 087
	332 SERIES	088 ~ 089

SPHERICAL ROLLER BEARINGS		PAGES FOR REFER
		092 ~ 117
	213 MB/W33, 213 K-MB/W33 SERIES	092 ~ 095
	222 MB/W33, 222 K-MB/W33 SERIES	096 ~ 103
	223 MB/W33, 223 K-MB/W33 SERIES	104 ~ 107
	230 MB/W33, 230 K-MB/W33 SERIES	108 ~ 109
	231 MB/W33, 231 K-MB/W33 SERIES	110 ~ 111
	232 MB/W33, 232 K-MB/W33 SERIES	112 ~ 113
	240 MB/W33, 240 K-MB/W33 SERIES	114 ~ 115
	241 MB/W33, 241 K-MB/W33 SERIES	116 ~ 117

<b>NEEDLE ROLLER BEARINGS</b>		<b>PAGES FOR REFER</b>
		123 ~ 207
<b>NEEDLE ROLLER AND CAGE ASSEMBLIES</b>		
	<b>K SERIES</b>	123 ~ 134
<b>DRAWN CUP NEEDLE ROLLER BEARINGS</b>		
	<b>HK &amp; BK SERIES</b>	138 ~ 142
	<b>HK.. L &amp; HK.. LL SERIES</b>	144 ~ 145
	<b>BK.. L SERIES</b>	144 ~ 145
<b>MACHINED-RING NEEDLE ROLLER BEARINGS</b>		
	<b>NA 48, NA 49, NA 59 &amp; NA 69 ZW SERIES</b>	150 ~ 161
	<b>NA 49.. L, RNA 49.. L, NA 49.. LL &amp; RNA 49.. LL SERIES</b>	162 ~ 163
	<b>RNA 48, RNA 49, RNA 59 &amp; RNA 69 ZW SERIES</b>	164 ~ 175
	<b>NK SERIES</b>	176 ~ 180
	<b>NKI SERIES</b>	181 ~ 183
<b>THRUST NEEDLE ROLLER BEARINGS</b>		
	<b>AXK 11, AS, WS &amp; GS SERIES</b>	188 ~ 191
	<b>LS SERIES</b>	192 ~ 193
	<b>K 811 &amp; K 812 SERIES</b>	194 ~ 195
<b>COMPLEX BEARINGS</b>		
	<b>NKX &amp; NKX.. Z SERIES</b>	200 ~ 201
	<b>NKXR &amp; NKXR.. Z SERIES</b>	202 ~ 203
	<b>NKIA 59 SERIES</b>	204 ~ 205
	<b>NKIB 59 SERIES</b>	206 ~ 207



## NEEDLE ROLLER BEARINGS

 PAGES FOR  
 REFER

214 ~ 273

### ROLLER FOLLOWERS

	NATR & NATR.. LL SERIES	214 ~ 215
	NATV & NATV.. LL SERIES	216 ~ 217
	NUTR SERIES	218 ~ 219
	NA 22.. LL & RNA 22.. LL SERIES	220 ~ 221

### CAM FOLLOWERS

	KR SERIES	226 ~ 227
	KRV SERIES	228 ~ 229
	NUKR SERIES	230 ~ 231

### COMPONENTS

	IR SERIES	235 ~ 250
---	-----------	-----------

### ONE-WAY CLUTCHES









	HF SERIES	253
	HFL SERIES	254





### MACHINED-RING NEEDLE ROLLER BEARINGS, SEPARABLE











	RNAO SERIES	258 ~ 263
	NAO SERIES	264 ~ 267

### SEALS



	G & SD SERIES	271 ~ 273











BALL BUSHING		PAGES FOR REFER
	LME..AS SERIES	284 ~ 285
	LME..UUOP AS SERIES	286 ~ 287
	LME..UUAJ AS SERIES	288 ~ 289
	LME-F SERIES	290 ~ 291
	LME-K SERIES	292 ~ 293
	LMES SERIES	294
	LMES..OP SERIES	295
	KH SERIES, OPEN TYPES & PP	296

ALUMINIUM HOUSINGS & COMPLETE UNITS		PAGES FOR REFER
	FGWA SERIES	298
	SB..AS, SB LME..UUAS SERIES	299
	SO..AS, SO LME..UUOP AS SERIES	300
	S2B..N, S2B..N+LME SERIES	301
	SBT..AS, SBT..AS+LME SERIES	302 ~ 303

TRACK ROLLER BEARINGS		PAGES FOR REFER
		317 ~ 327
	LR..NPP, LR..RRU SERIES	317
	LR 50..NPPU SERIES	318
	LR 52..NPPU, LR 52..KDD SERIES	319
	LR 53..NPPU SERIES	320
	LFR..ZZ, LFR..2RS SERIES	321
	RC., RE., RC..A1, RE..A1 SERIES	322
	RV.. SERIES	323
	RM..ZZ, RM..2RS SERIES	324
	RV..C, RV..E SERIES	325
	RPC., RPE.. SERIES	326
	RA..A SERIES	327

ROD ENDS		PAGES FOR REFER
		334 ~ 337
	BNM., BNML.. SERIES	334
	BNF., BNFL.. SERIES	335
	DM., DML.. SERIES	336
	DF., DFL.. SERIES	337

ROD ENDS		PAGES FOR REFER
		338 ~ 343
	BNM...K, BNML..K SERIES	338
	BNF...K, BNFL..K SERIES	339
	DMSS.., DMSSL.. SERIES	340
	DFSS.., DFSSL.. SERIES	341
	RBL SERIES	342
	RBI SERIES	343

BEARING UNITS		PAGES FOR REFER
		376 ~ 391
	UCP 200 SERIES	376 ~ 377
	UCF 200 SERIES	378 ~ 379
	UCFL 200 SERIES	380 ~ 381
	UCFC 200 SERIES	382 ~ 383
	UCT 200 SERIES	384 ~ 385
	UCUP 200 SERIES	386 ~ 387
	UC 200 SERIES	388
	AEL 200 SERIES	389
	AS 200 SERIES	390
	UK 200 SERIES	391



# BALL BEARINGS



**BALL BEARING**  
**SERIES 60**

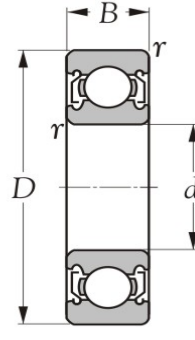
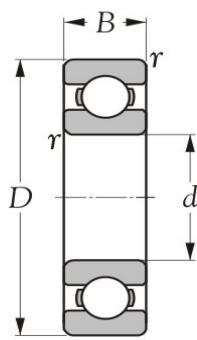

Shielded type  
(ZZ)



Non-contact  
sealed type  
(LLB)

Items (20)	Data  Model nos.	Dimension			Packing method	Quantity  Min. order qty.  Pcs	Delivery  Days	-	2014-09-01	Compare percentages (%)	Production code(s)		
		Bearing sizes										Unit price structure  USD	Unit price structure  USD
		d	D	B									
		mm											
1	<b>608 (5x8)</b>	8	22	7	N2	2,500	90	-	<b>0.31</b>	-	BN		
2	<b>608 LLB (5x8)</b>	8	22	7	N2	2,500	90	-	<b>0.35</b>	-	BN		
3	<b>608 ZZ (5x8)</b>	8	22	7	N2	2,500	90	-	<b>0.35</b>	-	BN		
4	<b>609 (5x8)</b>	9	24	7	N2	2,500	90	-	<b>0.33</b>	-	BN		
5	<b>609 LLB (5x8)</b>	9	24	7	N2	2,500	90	-	<b>0.36</b>	-	BN		
6	<b>609 ZZ (5x8)</b>	9	24	7	N2	2,500	90	-	<b>0.36</b>	-	BN		
7	<b>6000</b>	10	26	8	N1	2,500	90	-	<b>0.46</b>	-	BN		
8	* <b>6000 LLB</b>	10	26	8	N1	2,500	90	-	<b>0.50</b>	-	BN		
9	* <b>6000 ZZ</b>	10	26	8	N1	2,500	90	-	<b>0.48</b>	-	BN		
10	* <b>6001</b>	12	28	8	N1	2,500	90	-	<b>0.48</b>	-	BN		
11	* <b>6001 LLB</b>	12	28	8	N1	2,500	90	-	<b>0.53</b>	-	BN		
12	* <b>6001 ZZ</b>	12	28	8	N1	2,500	90	-	<b>0.50</b>	-	BN		
13	<b>6002</b>	15	32	9	N1	2,000	90	-	<b>0.51</b>	-	BN		
14	* <b>6002 LLB</b>	15	32	9	N1	2,000	90	-	<b>0.58</b>	-	BN		
15	* <b>6002 ZZ</b>	15	32	9	N1	2,000	90	-	<b>0.53</b>	-	BN		
16	<b>6003</b>	17	35	10	N1	1,800	90	-	<b>0.76</b>	-	BN		
17	* <b>6003 LLB</b>	17	35	10	N1	1,800	90	-	<b>0.81</b>	-	BN		
18	* <b>6003 ZZ</b>	17	35	10	N1	1,800	90	-	<b>0.79</b>	-	BN		
19	<b>6004</b>	20	42	12	N1	1,500	90	-	<b>0.98</b>	-	BN		
20	* <b>6004 LLB</b>	20	42	12	N1	1,500	90	-	<b>1.04</b>	-	BN		

Remark : 1. Marking on OEM products should all be marked on rubber seals/shields.( Details of marking please refer to the bottom pages "NIKO marking standard").  
2. Exceptional of OEM products, all the other bearings should be marked in workshops.(Details of marking please refer to the bottom pages NIKO marking standard). However,in case the min. order quantity does not meet the production requirement, marking on rubber seals/shields should be accepted.

Remark	Technical supplement		
	Cage(s)	Precision	Grease
	Steel - <input checked="" type="checkbox"/>	Class 6 (JIS)	Multemp SRL -40°C~+150°C
	Polymid - <input checked="" type="checkbox"/>	Class 0 (JIS)	Alvania S2 -25°C~+120°C
	Brass - <input checked="" type="checkbox"/>		

Qualified Sub-contractor(s)	Since
BN	2003
-	-
-	-

**BALL BEARING  
SERIES 60**

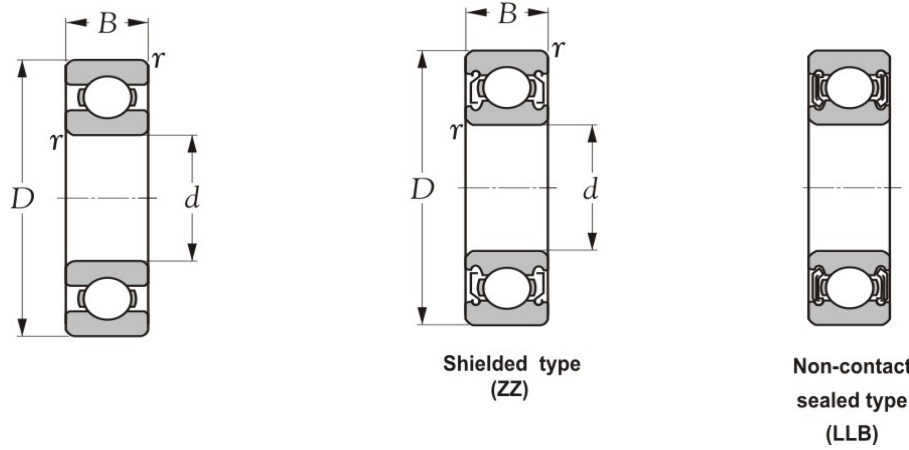

Items (20)	Data  Model nos.	Dimension			Packing method	Quantity  Min. order qty.  Pcs	Delivery  Days	-	2014-09-01	Compare percentages (%)	Production code(s)		
		Bearing sizes										Unit price structure  USD	Unit price structure  USD
		d	D	B									
		mm											
21	* 6004 ZZ	20	42	12	N1	1,500	90	-	1.01	-	BN		
22	* 6005	25	47	12	N1	1,000	90	-	0.78	-	HY		
23	* 6005 LLB	25	47	12	N1	1,000	90	-	0.79	-	HY		
24	* 6005 ZZ	25	47	12	N1	1,000	90	-	0.76	-	HY		
25	6006	30	55	13	N1	1,000	90	-	0.98	-	HY		
26	* 6006 LLB	30	55	13	N1	1,000	90	-	0.96	-	HY		
27	* 6006 ZZ	30	55	13	N1	1,000	90	-	0.93	-	HY		
28	6007	35	62	14	N1	800	90	-	1.23	-	HY		
29	* 6007 LLB	35	62	14	N1	800	90	-	1.34	-	HY		
30	* 6007 ZZ	35	62	14	N1	800	90	-	1.30	-	HY		
31	6008	40	68	15	N1	700	90	-	1.44	-	HY		
32	* 6008 LLB	40	68	15	N1	700	90	-	1.56	-	HY		
33	* 6008 ZZ	40	68	15	N1	700	90	-	1.50	-	HY		
34	6009	45	75	16	N1	-	-	-	-	-	-		
35	6009 LLB	45	75	16	N1	-	-	-	-	-	-		
36	6009 ZZ	45	75	16	N1	-	-	-	-	-	-		
37	6010	50	80	16	N1	-	-	-	-	-	-		
38	6010 LLB	50	80	16	N1	-	-	-	-	-	-		
39	6010 ZZ	50	80	16	N1	-	-	-	-	-	-		
40	6011	55	90	18	N1	-	-	-	-	-	-		

Remark : 1. Marking on OEM products should all be marked on rubber seals/shields.( Details of marking please refer to the bottom pages "NIKO marking standard").  
2. Exceptional of OEM products, all the other bearings should be marked in workshops.(Details of marking please refer to the bottom pages NIKO marking standard). However,in case the min. order quantity does not meet the production requirement, marking on rubber seals/shields should be accepted.

Remark	Technical supplement		
	Cage(s)	Precision	Grease
	Steel - <input checked="" type="checkbox"/>	Class 6 (JIS)	Multemp SRL -40°C~+150°C
	Polymid - <input checked="" type="checkbox"/>	Class 0 (JIS)	Alvania S2 -25°C~+120°C
	Brass - <input checked="" type="checkbox"/>		

Qualified Sub-contractor(s)	Since
BN	2003
HY	2004
JC	2005

**BALL BEARING**  
**SERIES 60**

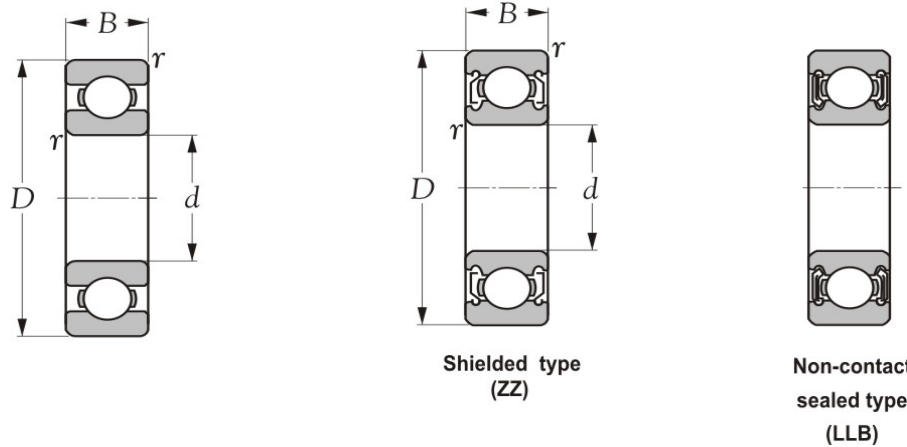

Items (20)	Data  Model nos.	Dimension			Packing method	Quantity  Min. order qty.  Pcs	Delivery  Days	-	2014-09-01	Compare percentages (%)	Production code(s)		
		Bearing sizes										Unit price structure  USD	Unit price structure  USD
		d	D	B									
		mm											
41	6011 LLB	55	90	18	N1	-	-	-	-	-	-		
42	6011 ZZ	55	90	18	N1	-	-	-	-	-	-		
43	6012	60	95	18	N1	-	-	-	-	-	-		
44	6012 LLB	60	95	18	N1	-	-	-	-	-	-		
45	6012 ZZ	60	95	18	N1	-	-	-	-	-	-		
46	6013	65	100	18	N1	-	-	-	-	-	-		
47	6013 LLB	65	100	18	N1	-	-	-	-	-	-		
48	6013 ZZ	65	100	18	N1	-	-	-	-	-	-		
49	6014	70	110	20	N1	-	-	-	-	-	-		
50	6014 LLB	70	110	20	N1	-	-	-	-	-	-		
51	6014 ZZ	70	110	20	N1	-	-	-	-	-	-		
52	6015	75	115	20	N1	-	-	-	-	-	-		
53	6015 LLB	75	115	20	N1	-	-	-	-	-	-		
54	6015 ZZ	75	115	20	N1	-	-	-	-	-	-		
55	6016	80	125	22	N1	-	-	-	-	-	-		
56	6016 LLB	80	125	22	N1	-	-	-	-	-	-		
57	6016 ZZ	80	125	22	N1	-	-	-	-	-	-		
58	6017	85	130	22	N1	-	-	-	-	-	-		
59	6017 LLB	85	130	22	N1	-	-	-	-	-	-		
60	6017 ZZ	85	130	22	N1	-	-	-	-	-	-		

Remark : 1. Marking on OEM products should all be marked on rubber seals/shields.( Details of marking please refer to the bottom pages "NIKO marking standard").  
2. Exceptional of OEM products, all the other bearings should be marked in workshops.(Details of marking please refer to the bottom pages NIKO marking standard). However,in case the min. order quantity does not meet the production requirement, marking on rubber seals/shields should be accepted.

Remark	Technical supplement		
	Cage(s)	Precision	Grease
	Steel - <input checked="" type="checkbox"/>	Class 6 (JIS)	Multemp SRL -40°C~+150°C
	Polymid - <input checked="" type="checkbox"/>	Class 0 (JIS)	Alvania S2 -25°C~+120°C
	Brass - <input checked="" type="checkbox"/>		

Qualified Sub-contractor(s)	Since
-	-
-	-
-	-



**BALL BEARING  
SERIES 60**

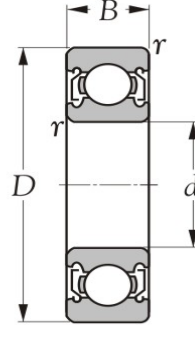
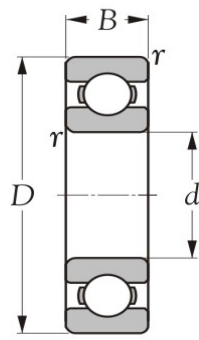

Shielded type  
(ZZ)



Non-contact  
sealed type  
(LLB)

Items (9)	Data  Model nos.	Dimension			Packing method	Quantity  Min. order qty.  Pcs	Delivery  Days	-		2014-09-01  Unit price structure  USD	Compare percentages (%)	Production code(s)
		Bearing sizes						Unit price structure	Unit price structure			
		d	D	B								
		mm						USD	USD			
61	<b>6018</b>	90	140	24	N1	-	-	-	-	-	-	-
62	<b>6018 LLB</b>	90	140	24	N1	-	-	-	-	-	-	-
63	<b>6018 ZZ</b>	90	140	24	N1	-	-	-	-	-	-	-
64	<b>6019</b>	95	145	24	N1	-	-	-	-	-	-	-
65	<b>6019 LLB</b>	95	145	24	N1	-	-	-	-	-	-	-
66	<b>6019 ZZ</b>	95	145	24	N1	-	-	-	-	-	-	-
67	<b>6020</b>	100	150	24	N1	-	-	-	-	-	-	-
68	<b>6020 LLB</b>	100	150	24	N1	-	-	-	-	-	-	-
69	<b>6020 ZZ</b>	100	150	24	N1	-	-	-	-	-	-	-

Remark : 1. Marking on OEM products should all be marked on rubber seals/shields.( Details of marking please refer to the bottom pages "NIKO marking standard").

2. Exceptional of OEM products, all the other bearings should be marked in workshops.(Details of marking please refer to the bottom pages NIKO marking standard). However,in case the min. order quantity does not meet the production requirement, marking on rubber seals/shields should be accepted.

Remark	Technical supplement		
	Cage(s)	Precision	Grease
	Steel - ✓	Class 6 (JIS)	Multemp SRL -40°C~+150°C
	Polymid - ✗	Class 0 (JIS)	Alvania S2 -25°C~+120°C
	Brass - ✗		

Qualified Sub-contractor(s)	Since
-	-
-	-
-	-

**BALL BEARING**  
**SERIES 62**

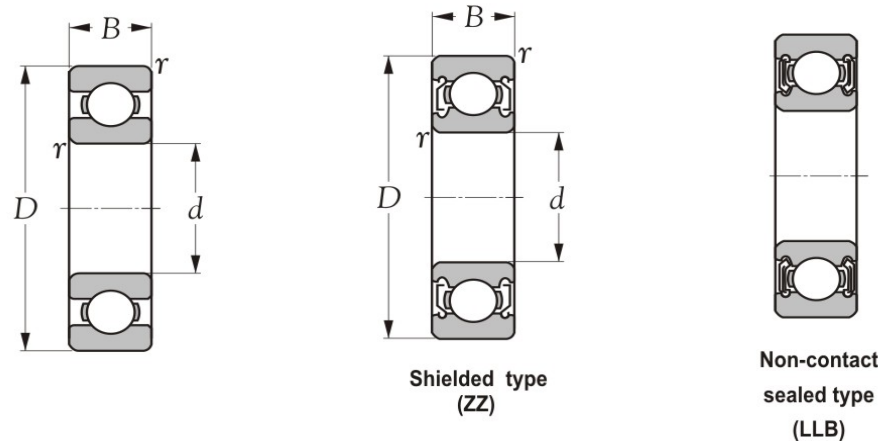

Items (20)	Data  Model nos.	Dimension			Packing method	Quantity  Min. order qty.  Pcs	Delivery  Days	-	2014-09-01	Compare percentages (%)	Production code(s)		
		Bearing sizes										Unit price structure  USD	Unit price structure  USD
		d	D	B									
		mm											
1	<b>628 (5x8)</b>	8	24	8	N2	2,500	90	-	<b>0.36</b>	-	BN		
2	<b>628 LLB (5x8)</b>	8	24	8	N2	2,500	90	-	<b>0.40</b>	-	BN		
3	<b>628 ZZ (5x8)</b>	8	24	8	N2	2,500	90	-	<b>0.40</b>	-	BN		
4	<b>629 (5x8)</b>	9	26	8	N2	2,500	90	-	<b>0.40</b>	-	BN		
5	* <b>629 LLB (5x8)</b>	9	26	8	N2	2,500	90	-	<b>0.41</b>	-	BN		
6	* <b>629 ZZ (5x8)</b>	9	26	8	N2	2,500	90	-	<b>0.41</b>	-	BN		
7	* <b>6200</b>	10	30	9	N1	2,500	90	-	<b>0.51</b>	-	BN		
8	* <b>6200 LLB</b>	10	30	9	N1	2,500	90	-	<b>0.58</b>	-	BN		
9	* <b>6200 ZZ</b>	10	30	9	N1	2,500	90	-	<b>0.53</b>	-	BN		
10	* <b>6201</b>	12	32	10	N1	2,500	90	-	<b>0.55</b>	-	BN		
11	* <b>6201 LLB</b>	12	32	10	N1	2,500	90	-	<b>0.58</b>	-	BN		
12	* <b>6201 ZZ</b>	12	32	10	N1	2,500	90	-	<b>0.58</b>	-	BN		
13	<b>6202</b>	15	35	11	N1	2,000	90	-	<b>0.58</b>	-	BN		
14	* <b>6202 LLB</b>	15	35	11	N1	2,000	90	-	<b>0.64</b>	-	BN		
15	* <b>6202 ZZ</b>	15	35	11	N1	2,000	90	-	<b>0.61</b>	-	BN		
16	<b>6203</b>	17	40	12	N1	1,800	90	-	<b>0.83</b>	-	BN		
17	* <b>6203 LLB</b>	17	40	12	N1	1,800	90	-	<b>0.91</b>	-	BN		
18	* <b>6203 ZZ</b>	17	40	12	N1	1,800	90	-	<b>0.89</b>	-	BN		
19	* <b>6204</b>	20	47	14	N1	1,500	90	-	<b>1.01</b>	-	BN		
20	* <b>6204 LLB</b>	20	47	14	N1	1,500	90	-	<b>1.08</b>	-	BN		

Remark : 1. Marking on OEM products should all be marked on rubber seals/shields.( Details of marking please refer to the bottom pages "NIKO marking standard").

2. Exceptional of OEM products, all the other bearings should be marked in workshops.(Details of marking please refer to the bottom pages NIKO marking standard). However,in case the min. order quantity does not meet the production requirement, marking on rubber seals/shields should be accepted.

Remark	Technical supplement		
	Cage(s)	Precision	Grease
	Steel - <input checked="" type="checkbox"/>	Class 6 (JIS)	Multemp SRL -40°C~+150°C
	Polymid - <input checked="" type="checkbox"/>	Class 0 (JIS)	Alvania S2 -25°C~+120°C
	Brass - <input checked="" type="checkbox"/>		

Qualified Sub-contractor(s)	Since
BN	2003
-	-
-	-

**BALL BEARING**  
**SERIES 62**

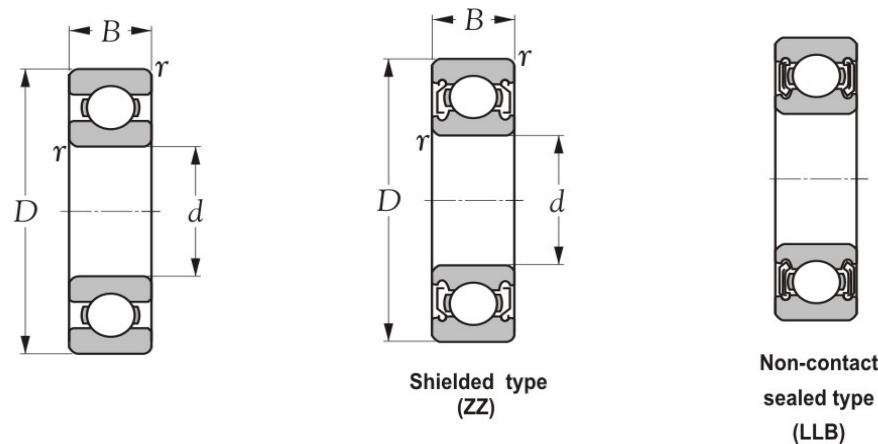

Items (20)	Data  Model nos.	Dimension			Packing method	Quantity  Min. order qty.  Pcs	Delivery  Days	-	2014-09-01	Compare percentages (%)	Production code(s)		
		Bearing sizes										Unit price structure  USD	Unit price structure  USD
		d	D	B									
		mm											
21	* 6204 ZZ	20	47	14	N1	1,500	90	-	1.04	-	BN		
22	* 6205	25	52	15	N1	1,000	90	-	1.01	-	HY		
23	* 6205 LLB	25	52	15	N1	1,000	90	-	0.99	-	HY		
24	* 6205 ZZ	25	52	15	N1	1,000	90	-	0.99	-	HY		
25	6206	30	62	16	N1	1,000	90	-	1.38	-	HY		
26	* 6206 LLB	30	62	16	N1	1,000	90	-	1.35	-	HY		
27	* 6206 ZZ	30	62	16	N1	1,000	90	-	1.34	-	HY		
28	6207	35	72	17	N1	800	90	-	1.85	-	HY		
29	* 6207 LLB	35	72	17	N1	800	90	-	1.95	-	HY		
30	* 6207 ZZ	35	72	17	N1	800	90	-	1.90	-	HY		
31	6208	40	80	18	N1	-	-	-	-	-	-		
32	* 6208 LLB	40	80	18	N1	-	-	-	-	-	-		
33	* 6208 ZZ	40	80	18	N1	-	-	-	-	-	-		
34	6209	45	85	19	N1	-	-	-	-	-	-		
35	6209 LLB	45	85	19	N1	-	-	-	-	-	-		
36	6209 ZZ	45	85	19	N1	-	-	-	-	-	-		
37	6210	50	90	20	N1	-	-	-	-	-	-		
38	6210 LLB	50	90	20	N1	-	-	-	-	-	-		
39	6210 ZZ	50	90	20	N1	-	-	-	-	-	-		
40	6211	55	100	21	N1	-	-	-	-	-	-		

Remark : 1. Marking on OEM products should all be marked on rubber seals/shields.( Details of marking please refer to the bottom pages "NIKO marking standard").

2. Exceptional of OEM products, all the other bearings should be marked in workshops.(Details of marking please refer to the bottom pages NIKO marking standard). However,in case the min. order quantity does not meet the production requirement, marking on rubber seals/shields should be accepted.

Remark	Technical supplement		
	Cage(s)	Precision	Grease
	Steel - ✓	Class 6 (JIS)	Multemp SRL -40°C~+150°C
	Polymid - ✗	Class 0 (JIS)	Alvania S2 -25°C~+120°C
	Brass - ✗		

Qualified Sub-contractor(s)	Since
BN	2003
HY	2004
-	-

**BALL BEARING**  
**SERIES 62**

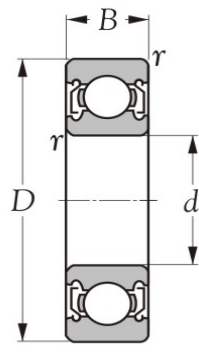
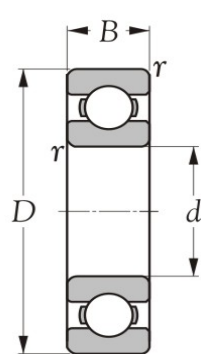

Shielded type  
(ZZ)



Non-contact  
sealed type  
(LLB)

Items (20)	Data  Model nos.	Dimension			Packing method	Quantity  Min. order qty.  Pcs	Delivery  Days	-	2014-09-01	Compare percentages (%)	Production code(s)		
		Bearing sizes										Unit price structure  USD	Unit price structure  USD
		d	D	B									
		mm											
41	6211 LLB	55	100	21	N1	-	-	-	-	-	-		
42	6211 ZZ	55	100	21	N1	-	-	-	-	-	-		
43	6212	60	110	22	N1	-	-	-	-	-	-		
44	6212 LLB	60	110	22	N1	-	-	-	-	-	-		
45	6212 ZZ	60	110	22	N1	-	-	-	-	-	-		
46	6213	65	120	23	N1	-	-	-	-	-	-		
47	6213 LLB	65	120	23	N1	-	-	-	-	-	-		
48	6213 ZZ	65	120	23	N1	-	-	-	-	-	-		
49	6214	70	125	24	N1	-	-	-	-	-	-		
50	6214 LLB	70	125	24	N1	-	-	-	-	-	-		
51	6214 ZZ	70	125	24	N1	-	-	-	-	-	-		
52	6215	75	130	25	N1	-	-	-	-	-	-		
53	6215 LLB	75	130	25	N1	-	-	-	-	-	-		
54	6215 ZZ	75	130	25	N1	-	-	-	-	-	-		
55	6216	80	140	26	N1	-	-	-	-	-	-		
56	6216 LLB	80	140	26	N1	-	-	-	-	-	-		
57	6216 ZZ	80	140	26	N1	-	-	-	-	-	-		
58	6217	85	150	28	N1	-	-	-	-	-	-		
59	6217 LLB	85	150	28	N1	-	-	-	-	-	-		
60	6217 ZZ	85	150	28	N1	-	-	-	-	-	-		

Remark : 1. Marking on OEM products should all be marked on rubber seals/shields.( Details of marking please refer to the bottom pages "NIKO marking standard").

2. Exceptional of OEM products, all the other bearings should be marked in workshops.(Details of marking please refer to the bottom pages NIKO marking standard). However,in case the min. order quantity does not meet the production requirement, marking on rubber seals/shields should be accepted.

Remark	Technical supplement		
	Cage(s)	Precision	Grease
	Steel - <input checked="" type="checkbox"/>	Class 6 (JIS)	Multemp SRL -40°C~+150°C
	Polymid - <input checked="" type="checkbox"/>	Class 0 (JIS)	Alvania S2 -25°C~+120°C
	Brass - <input checked="" type="checkbox"/>		

Qualified Sub-contractor(s)	Since
-	-
-	-
-	-

**BALL BEARING  
SERIES 62**

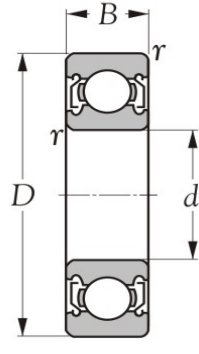
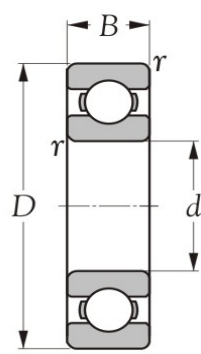

Shielded type  
(ZZ)



Non-contact  
sealed type  
(LLB)

Items (9)	Data  Model nos.	Dimension			Packing method	Quantity  Min. order qty.  Pcs	Delivery  Days	-	2014-09-01	Compare percentages (%)	Production code(s)		
		Bearing sizes										Unit price structure  USD	Unit price structure  USD
		d	D	B									
		mm											
61	<b>6218</b>	90	160	30	N1	-	-	-	-	-	-		
62	<b>6218 LLB</b>	90	160	30	N1	-	-	-	-	-	-		
63	<b>6218 ZZ</b>	90	160	30	N1	-	-	-	-	-	-		
64	<b>6219</b>	95	170	32	N1	-	-	-	-	-	-		
65	<b>6219 LLB</b>	95	170	32	N1	-	-	-	-	-	-		
66	<b>6219 ZZ</b>	95	170	32	N1	-	-	-	-	-	-		
67	<b>6220</b>	100	180	34	N1	-	-	-	-	-	-		
68	<b>6220 LLB</b>	100	180	34	N1	-	-	-	-	-	-		
69	<b>6220 ZZ</b>	100	180	34	N1	-	-	-	-	-	-		

Remark : 1. Marking on OEM products should all be marked on rubber seals/shields.( Details of marking please refer to the bottom pages "NIKO marking standard").  
2. Exceptional of OEM products, all the other bearings should be marked in workshops.(Details of marking please refer to the bottom pages NIKO marking standard). However,in case the min. order quantity does not meet the production requirement, marking on rubber seals/shields should be accepted.

Remark	Technical supplement		
	Cage(s)	Precision	Grease
	Steel - ✓	Class 6 (JIS)	Multemp SRL -40°C~+150°C
	Polymid - ×	Class 0 (JIS)	Alvania S2 -25°C~+120°C
	Brass - ×		

Qualified Sub-contractor(s)	Since
-	-
-	-
-	-

**BALL BEARING**  
**SERIES 63**

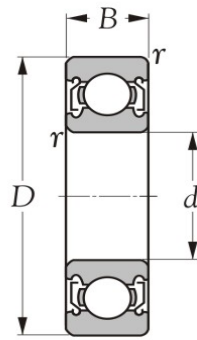
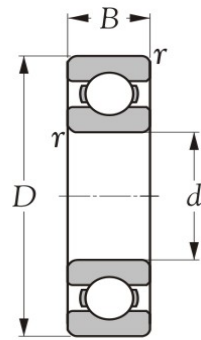

Shielded type  
(ZZ)



Non-contact  
sealed type  
(LLB)

Items (20)	Data  Model nos.	Dimension			Packing method	Quantity  Min. order qty.  Pcs	Delivery  Days	-	2014-09-01	Compare percentages (%)	Production code(s)		
		Bearing sizes										Unit price structure  USD	Unit price structure  USD
		d	D	B									
		mm											
1	<b>6300</b>	10	35	11	N1	1,250	90	-	<b>0.68</b>	-	BN		
2	<b>6300 LLB</b>	10	35	11	N1	1,250	90	-	<b>0.73</b>	-	BN		
3	<b>6300 ZZ</b>	10	35	11	N1	1,250	90	-	<b>0.73</b>	-	BN		
4	<b>6301</b>	12	37	12	N1	1,250	90	-	<b>0.73</b>	-	BN		
5	<b>6301 LLB</b>	12	37	12	N1	1,250	90	-	<b>0.76</b>	-	BN		
6	<b>6301 ZZ</b>	12	37	12	N1	1,250	90	-	<b>0.76</b>	-	BN		
7	<b>6302</b>	15	42	13	N1	1,000	90	-	<b>0.86</b>	-	BN		
8	<b>6302 LLB</b>	15	42	13	N1	1,000	90	-	<b>0.94</b>	-	BN		
9	<b>6302 ZZ</b>	15	42	13	N1	1,000	90	-	<b>0.94</b>	-	BN		
10	<b>6303</b>	17	47	14	N1	-	-	-	-	-	-		
11	<b>6303 LLB</b>	17	47	14	N1	-	-	-	-	-	-		
12	<b>6303 ZZ</b>	17	47	14	N1	-	-	-	-	-	-		
13	<b>6304</b>	20	52	15	N1	-	-	-	-	-	-		
14	<b>6304 LLB</b>	20	52	15	N1	-	-	-	-	-	-		
15	<b>6304 ZZ</b>	20	52	15	N1	-	-	-	-	-	-		
16	<b>6305</b>	25	62	17	N1	-	-	-	-	-	-		
17	<b>6305 LLB</b>	25	62	17	N1	-	-	-	-	-	-		
18	<b>6305 ZZ</b>	25	62	17	N1	-	-	-	-	-	-		
19	<b>6306</b>	30	72	19	N1	-	-	-	-	-	-		
20	<b>6306 LLB</b>	30	72	19	N1	-	-	-	-	-	-		

Remark : 1. Marking on OEM products should all be marked on rubber seals/shields.( Details of marking please refer to the bottom pages "NIKO marking standard").  
2. Exceptional of OEM products, all the other bearings should be marked in workshops.(Details of marking please refer to the bottom pages NIKO marking standard). However,in case the min. order quantity does not meet the production requirement, marking on rubber seals/shields should be accepted.

Remark	Technical supplement		
	Cage(s)	Precision	Grease
	Steel - ✓	Class 6 (JIS)	Multemp SRL -40°C~+150°C
	Polymid - ×	Class 0 (JIS)	Alvania S2 -25°C~+120°C
	Brass - ×		

Qualified Sub-contractor(s)	Since
BN	2003
-	-
-	-

**BALL BEARING**  
**SERIES 63**

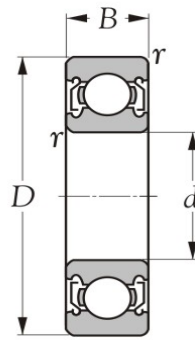
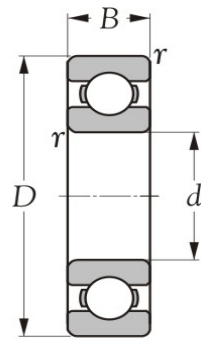

Shielded type  
(ZZ)



Non-contact  
sealed type  
(LLB)

Items (20)	Data  Model nos.	Dimension			Packing method	Quantity  Min. order qty.  Pcs	Delivery  Days	-	2014-09-01	Compare percentages (%)	Production code(s)		
		Bearing sizes										Unit price structure  USD	Unit price structure  USD
		d	D	B									
		mm											
21	<b>6306 ZZ</b>	30	72	19	N1	-	-	-	-	-			
22	<b>6307</b>	35	80	21	N1	-	-	-	-	-			
23	<b>6307 LLB</b>	35	80	21	N1	-	-	-	-	-			
24	<b>6307 ZZ</b>	35	80	21	N1	-	-	-	-	-			
25	<b>6308</b>	40	90	23	N1	-	-	-	-	-			
26	<b>6308 LLB</b>	40	90	23	N1	-	-	-	-	-			
27	<b>6308 ZZ</b>	40	90	23	N1	-	-	-	-	-			
28	<b>6309</b>	45	100	25	N1	-	-	-	-	-			
29	<b>6309 LLB</b>	45	100	25	N1	-	-	-	-	-			
30	<b>6309 ZZ</b>	45	100	25	N1	-	-	-	-	-			
31	<b>6310</b>	50	110	27	N1	-	-	-	-	-			
32	<b>6310 LLB</b>	50	110	27	N1	-	-	-	-	-			
33	<b>6310 ZZ</b>	50	110	27	N1	-	-	-	-	-			
34	<b>6311</b>	55	120	29	N1	-	-	-	-	-			
35	<b>6311 LLB</b>	55	120	29	N1	-	-	-	-	-			
36	<b>6311 ZZ</b>	55	120	29	N1	-	-	-	-	-			
37	<b>6312</b>	60	130	31	N1	-	-	-	-	-			
38	<b>6312 LLB</b>	60	130	31	N1	-	-	-	-	-			
39	<b>6312 ZZ</b>	60	130	31	N1	-	-	-	-	-			
40	<b>6313</b>	65	140	33	N1	-	-	-	-	-			

Remark : 1. Marking on OEM products should all be marked on rubber seals/shields.( Details of marking please refer to the bottom pages "NIKO marking standard").  
2. Exceptional of OEM products, all the other bearings should be marked in workshops.(Details of marking please refer to the bottom pages NIKO marking standard). However,in case the min. order quantity does not meet the production requirement, marking on rubber seals/shields should be accepted.



**Technical supplement**

<b>Cage(s)</b>	<b>Precision</b>	<b>Grease</b>
Steel - ✓	Class 6 (JIS)	Multemp SRL -40°C~+150°C
Polymid - ✗	Class 0 (JIS)	Alvania S2 -25°C~+120°C
Brass - ✗		

Qualified Sub-contractor(s)	Since
-	-
-	-
-	-

**BALL BEARING**  
**SERIES 63**

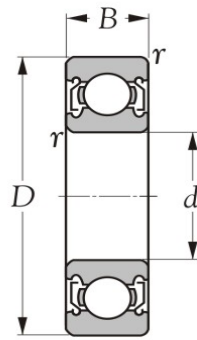
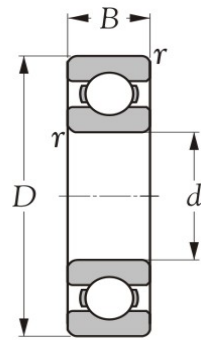

Shielded type  
(ZZ)



Non-contact  
sealed type  
(LLB)

Items (20)	Data  Model nos.	Dimension			Packing method	Quantity  Min. order qty.  Pcs	Delivery  Days	-	2014-09-01	Compare percentages (%)	Production code(s)		
		Bearing sizes										Unit price structure  USD	Unit price structure  USD
		d	D	B									
		mm											
41	6313 LLB	65	140	33	N1	-	-	-	-	-	-		
42	6313 ZZ	65	140	33	N1	-	-	-	-	-	-		
43	6314	70	150	35	N1	-	-	-	-	-	-		
44	6314 LLB	70	150	35	N1	-	-	-	-	-	-		
45	6314 ZZ	70	150	35	N1	-	-	-	-	-	-		
46	6315	75	160	37	N1	-	-	-	-	-	-		
47	6315 LLB	75	160	37	N1	-	-	-	-	-	-		
48	6315 ZZ	75	160	37	N1	-	-	-	-	-	-		
49	6316	80	170	39	N1	-	-	-	-	-	-		
50	6316 LLB	80	170	39	N1	-	-	-	-	-	-		
51	6316 ZZ	80	170	39	N1	-	-	-	-	-	-		
52	6317	85	180	41	N1	-	-	-	-	-	-		
53	6317 LLB	85	180	41	N1	-	-	-	-	-	-		
54	6317 ZZ	85	180	41	N1	-	-	-	-	-	-		
55	6318	90	190	43	N1	-	-	-	-	-	-		
56	6318 LLB	90	190	43	N1	-	-	-	-	-	-		
57	6318 ZZ	90	190	43	N1	-	-	-	-	-	-		
58	6319	95	200	45	N1	-	-	-	-	-	-		
59	6319 ZZ	95	200	45	N1	-	-	-	-	-	-		
60	6320	100	215	47	N1	-	-	-	-	-	-		

Remark : 1. Marking on OEM products should all be marked on rubber seals/shields.( Details of marking please refer to the bottom pages "NIKO marking standard").  
2. Exceptional of OEM products, all the other bearings should be marked in workshops.(Details of marking please refer to the bottom pages NIKO marking standard). However,in case the min. order quantity does not meet the production requirement, marking on rubber seals/shields should be accepted.



**Technical supplement**

<b>Cage(s)</b>	<b>Precision</b>	<b>Grease</b>
Steel - ✓	Class 6 (JIS)	Multemp SRL -40°C~+150°C
Polymid - ✗	Class 0 (JIS)	Alvania S2 -25°C~+120°C
Brass - ✗		

Qualified Sub-contractor(s)	Since
-	-
-	-
-	-



**BALL BEARING**  
**SERIES 63**

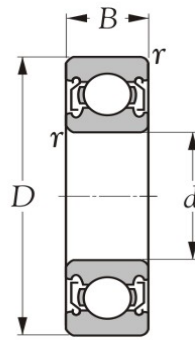
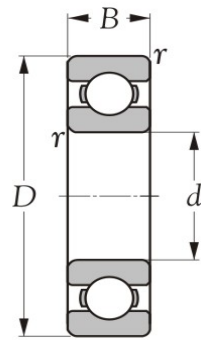

Shielded type  
(ZZ)



Non-contact  
sealed type  
(LLB)

Items (1)	Data  Model nos.	Dimension			Packing method	Quantity  Min. order qty.	Delivery  Days	Unit price structure  USD	2014-09-01  Unit price structure  USD	Compare percentages (%)	Production code(s)
		Bearing sizes									
		d	D	B							
		mm				Pcs		USD	USD		
61	<b>6320 ZZ</b>	100	215	47	N1	-	-	-	-	-	-

Remark : 1. Marking on OEM products should all be marked on rubber seals/shields.( Details of marking please refer to the bottom pages "NIKO marking standard").  
2. Exceptional of OEM products, all the other bearings should be marked in workshops.(Details of marking please refer to the bottom pages NIKO marking standard). However,in case the min. order quantity does not meet the production requirement, marking on rubber seals/shields should be accepted.



**Technical supplement**

Cage(s)	Precision	Grease
Steel - ✓	Class 6 (JIS)	Multemp SRL -40°C~+150°C
Polymid - ✗	Class 0 (JIS)	Alvania S2 -25°C~+120°C
Brass - ✗		

Qualified Sub-contractor(s)	Since
-	-
-	-
-	-

**BALL BEARING**  
**SERIES 160**

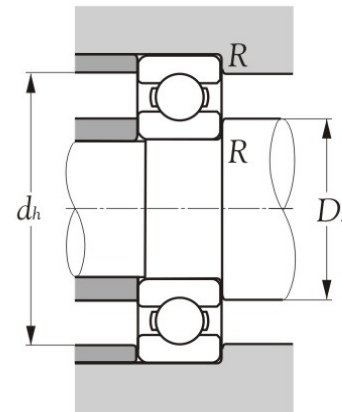
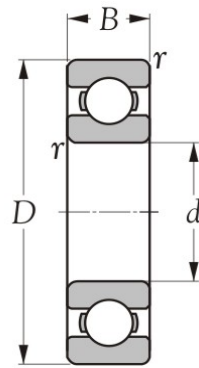

Items (20)	Data  Model nos.	Dimension			Packing method	Quantity  Min. order qty.	Delivery  Days	-	2014-09-01	Compare percentages (%)	Production code(s)		
		Bearing sizes										Unit price structure	Unit price structure
		d	D	B									
		mm				Pcs							
1	<b>16001 (10x1)</b>	12	28	7	N2	1,000	120	-	<b>0.64</b>	-	CHYX		
2	<b>16002 (10x1)</b>	15	32	8	N2	1,000	120	-	<b>0.74</b>	-	CHYX		
3	<b>16003 (2x1)</b>	17	35	8	N2	1,000	120	-	<b>0.78</b>	-	CHYX		
4	<b>16004 (2x1)</b>	20	42	8	N2	1,000	120	-	<b>0.91</b>	-	CHYX		
5	<b>16005 (2x1)</b>	25	47	8	N2	800	120	-	<b>1.05</b>	-	CHYX		
6	<b>16006</b>	30	55	9	N1	800	120	-	<b>1.25</b>	-	CHYX		
7	<b>16007</b>	35	62	9	N1	800	120	-	<b>1.49</b>	-	CHYX		
8	<b>16008</b>	40	68	9	N1	500	120	-	<b>1.95</b>	-	CHYX		
9	<b>16009</b>	45	75	10	N1	500	120	-	<b>2.23</b>	-	CHYX		
10	<b>16010</b>	50	80	10	N1	400	120	-	<b>2.68</b>	-	CHYX		
11	<b>16011</b>	55	90	11	N1	300	120	-	<b>3.68</b>	-	JC		
12	<b>16012</b>	60	95	11	N1	250	120	-	<b>4.03</b>	-	JC		
13	<b>16013</b>	65	100	11	N1	250	120	-	<b>4.45</b>	-	JC		
14	<b>16014</b>	70	110	13	N1	200	120	-	<b>5.98</b>	-	JC		
15	<b>16015</b>	75	115	13	N1	150	120	-	<b>6.80</b>	-	JC		
16	<b>16016</b>	80	125	14	N1	120	120	-	<b>9.39</b>	-	JC		
17	<b>16017</b>	85	130	14	N1	100	120	-	<b>10.81</b>	-	JC		
18	<b>16018</b>	90	140	16	N1	100	120	-	<b>13.06</b>	-	JC		
19	<b>16019</b>	95	145	16	N1	80	120	-	<b>14.80</b>	-	JC		
20	<b>16020</b>	100	150	16	N1	80	120	-	<b>15.93</b>	-	JC		

Remark : 1. Marking on OEM products should all be marked on rubber seals/shields.( Details of marking please refer to the bottom pages "NIKO marking standard").

2. Exceptional of OEM products, all the other bearings should be marked in workshops.(Details of marking please refer to the bottom pages NIKO marking standard). However,in case the min. order quantity does not meet the production requirement, marking on rubber seals/shields should be accepted.

<b>Remark</b>	<b>Technical supplement</b>		
	<b>Cage(s)</b>	<b>Precision</b>	<b>Grease</b>
	Steel - <input checked="" type="checkbox"/>	Class 6 (JIS)	Nil
	Polymid - <input checked="" type="checkbox"/>		
Brass - <input checked="" type="checkbox"/>			

<b>Qualified Sub-contractor(s)</b>	Since
CHYX	2008
JC	2005
-	-

**BALL BEARING  
SERIES 160**

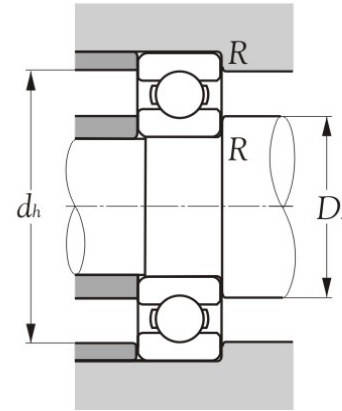
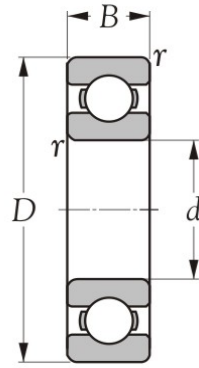

Items (3)	Data  Model nos.	Dimension			Packing method	Quantity  Min. order qty.	Delivery	-	2014-09-01	Compare percentages (%)	Production code(s)		
		Bearing sizes										Unit price structure	Unit price structure
		d	D	B									
		mm			Pcs	Days	USD	USD					
21	<b>16021</b>	105	160	18	N1	-	-	-	-	-			
22	<b>16022</b>	110	170	19	N1	-	-	-	-	-			
23	<b>16024</b>	120	180	19	N1	-	-	-	-	-			

Remark : 1. Marking on OEM products should all be marked on rubber seals/shields.( Details of marking please refer to the bottom pages "NIKO marking standard").

2. Exceptional of OEM products, all the other bearings should be marked in workshops.(Details of marking please refer to the bottom pages NIKO marking standard). However,in case the min. order quantity does not meet the production requirement, marking on rubber seals/shields should be accepted.

Remark	Technical supplement							
	Cage(s)	Precision	Grease					
	<table border="1"> <tr> <td>Steel -</td> <td>✓</td> </tr> <tr> <td>Polymid -</td> <td>×</td> </tr> <tr> <td>Brass -</td> <td>×</td> </tr> </table>	Steel -	✓	Polymid -	×	Brass -	×	Class 6 (JIS)
Steel -	✓							
Polymid -	×							
Brass -	×							

Qualified Sub-contractor(s)	Since
JC	2005
-	-
-	-

**BALL BEARING**  
**SERIES 68**

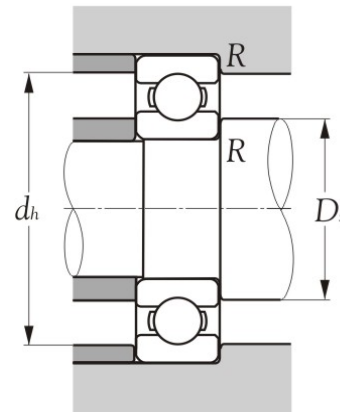
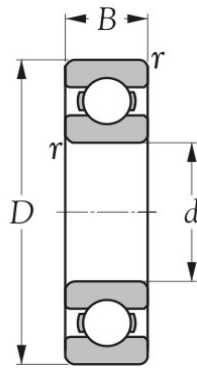

Items (17)	Data  Model nos.	Dimension			Packing method	Quantity  Min. order qty.	Delivery  Days	-		Compare percentages (%)	Production code(s)
		Bearing sizes						Unit price structure	2014-09-01 Unit price structure		
		d	D	B							
		mm				Pcs					
1	<b>6800 (UG) (5x10)</b>	10	19	5	N2	200	90	-	<b>0.35</b>	-	TY
2	<b>6801 (UG) (5x10)</b>	12	21	5	N2	200	90	-	<b>0.35</b>	-	TY
3	<b>6802 (UG) (5x4)</b>	15	24	5	N2	200	90	-	<b>0.48</b>	-	TY
4	<b>6803 (UG) (5x4)</b>	17	26	5	N2	200	90	-	<b>0.51</b>	-	TY
5	<b>6804 (UG) (5x4)</b>	20	32	7	N2	200	90	-	<b>0.60</b>	-	TY
6	* <b>6805 (UG) (5x4)</b>	25	37	7	N2	200	90	-	<b>0.73</b>	-	TY
7	* <b>6806 (UG) (5x4)</b>	30	42	7	N2	200	90	-	<b>0.91</b>	-	TY
8	<b>6807 (UG)</b>	35	47	7	N1	200	90	-	<b>1.10</b>	-	TY
9	* <b>6808 (UG)</b>	40	52	7	N1	200	90	-	<b>1.66</b>	-	TY
10	<b>6809 (UG)</b>	45	58	7	N1	200	90	-	<b>2.16</b>	-	TY
11	<b>6810 (UG)</b>	50	65	7	N1	200	90	-	<b>2.46</b>	-	TY
12	<b>6811 (UG)</b>	55	72	9	N1	200	90	-	<b>2.70</b>	-	TY
13	<b>6812 (UG)</b>	60	78	10	N1	20	90	-	<b>3.36</b>	-	TY
14	<b>6813 (UG)</b>	65	85	10	N1	20	90	-	<b>5.23</b>	-	TY
15	<b>6814 (UG)</b>	70	90	10	N1	20	90	-	<b>6.50</b>	-	TY
16	<b>6815 (UG)</b>	75	95	10	N1	20	90	-	<b>9.13</b>	-	TY
17	<b>6816 (UG)</b>	80	100	10	N1	20	90	-	<b>10.93</b>	-	TY

Remark : 1. Marking on OEM products should all be marked on rubber seals/shields.( Details of marking please refer to the bottom pages "NIKO marking standard").  
2. Exceptional of OEM products, all the other bearings should be marked in workshops.(Details of marking please refer to the bottom pages NIKO marking standard). However,in case the min. order quantity does not meet the production requirement, marking on rubber seals/shields should be accepted.

Remark	Technical supplement									
	Cage(s)	Precision	Grease							
	<table border="1"> <tr> <td>Steel -</td> <td>✓</td> </tr> <tr> <td>Polymid -</td> <td>×</td> </tr> <tr> <td>Brass -</td> <td>×</td> </tr> </table>	Steel -	✓	Polymid -	×	Brass -	×	<table border="1"> <tr> <td>Class 0 (JIS)</td> </tr> </table>	Class 0 (JIS)	<table border="1"> <tr> <td>Nil</td> </tr> </table>
Steel -	✓									
Polymid -	×									
Brass -	×									
Class 0 (JIS)										
Nil										

Qualified Sub-contractor(s)	Since
TY	2003
-	-
-	-

BALL BEARING

SERIES **68..LLB, 68..ZZ**

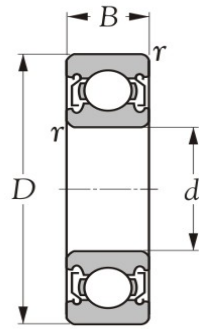

Shielded type  
(ZZ)



Non-contact  
sealed type  
(LLB)

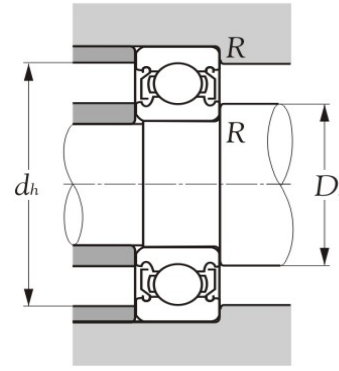

Items (20)	Data  Model nos.	Dimension			Packing method	Quantity  Min. order qty.  Pcs	Delivery  Days	-	2014-09-01  Unit price structure  USD	Compare percentages (%)	Production code(s)
		Bearing sizes									
		d	D	B							
		mm									
18	* 6800 LLB (5x10)	10	19	5	N2	5,000	90	-	0.38	-	TY
19	* 6801 LLB (5x10)	12	21	5	N2	5,000	90	-	0.38	-	TY
20	* 6802 LLB (5x4)	15	24	5	N2	3,500	90	-	0.46	-	TY
21	* 6803 LLB (5x4)	17	26	5	N2	3,500	90	-	0.51	-	TY
22	* 6804 LLB (5x4)	20	32	7	N2	3,500	90	-	0.60	-	TY
23	* 6805 LLB (5x4)	25	37	7	N2	2,000	90	-	0.73	-	TY
24	* 6806 LLB (5x4)	30	42	7	N2	2,000	90	-	1.04	-	TY
25	* 6807 LLB	35	47	7	N1	1,500	90	-	1.19	-	TY
26	* 6808 LLB	40	52	7	N1	1,500	90	-	1.71	-	TY
27	* 6809 LLB	45	58	7	N1	700	90	-	2.29	-	TY
28	* 6810 LLB	50	65	7	N1	700	90	-	2.64	-	TY
29	* 6811 LLB	55	72	9	N1	500	90	-	3.21	-	TY
30	* 6812 LLB	60	78	10	N1	500	90	-	3.60	-	TY
31	* 6813 LLB	65	85	10	N1	300	90	-	5.58	-	TY
32	6814 LLB	70	90	10	N1	300	90	-	7.29	-	TY
33	6815 LLB	75	95	10	N1	200	90	-	9.89	-	TY
34	6816 LLB	80	100	10	N1	200	90	-	11.74	-	TY
35	6800 ZZ (5x10)	10	19	5	N2	5,000	90	-	0.38	-	TY
36	6801 ZZ (5x10)	12	21	5	N2	5,000	90	-	0.41	-	TY
37	* 6802 ZZ (5x4)	15	24	5	N2	3,500	90	-	0.46	-	TY

Remark : 1. Marking on OEM products should all be marked on rubber seals/shields.( Details of marking please refer to the bottom pages "NIKO marking standard").

2. Exceptional of OEM products, all the other bearings should be marked in workshops.(Details of marking please refer to the bottom pages NIKO marking standard). However,in case the min. order quantity does not meet the production requirement, marking on rubber seals/shields should be accepted.

Remark	Technical supplement		
	Cage(s)	Precision	Grease
	Steel - <input checked="" type="checkbox"/>	Class 0 (JIS)	Alvania S2 -25℃~+120℃
	Polymid - <input checked="" type="checkbox"/>		
	Brass - <input checked="" type="checkbox"/>		

Qualified Sub-contractor(s)	Since
TY	2003
-	-
-	-

**BALL BEARING**  
**SERIES 68..LLB, 68..ZZ**

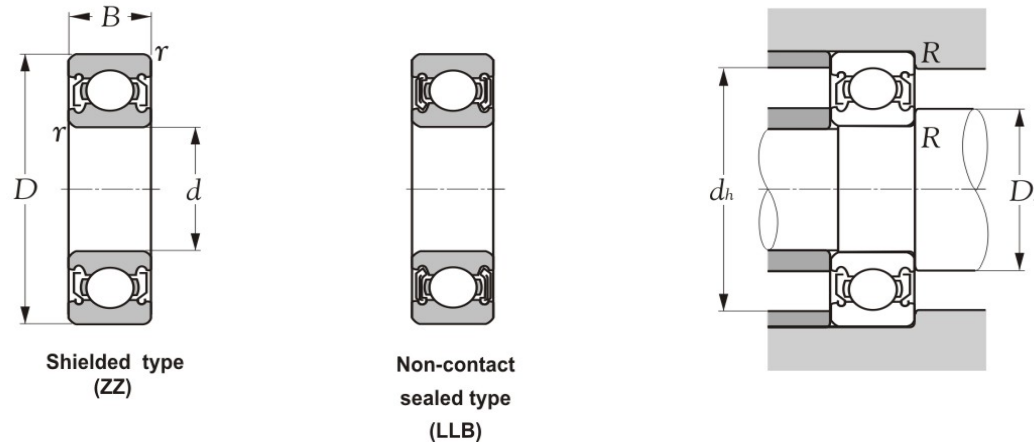

Items (14)	Data  Model nos.	Dimension			Packing method	Quantity  Min. order qty.	Delivery  Days	-	2014-09-01	Compare percentages (%)	Production code(s)		
		Bearing sizes										Unit price structure	Unit price structure
		d	D	B									
		mm				Pcs							
38	<b>6803 ZZ (5x4)</b>	17	26	5	N2	3,500	90	-	<b>0.50</b>	-	TY		
39	* <b>6804 ZZ (5x4)</b>	20	32	7	N2	3,500	90	-	<b>0.63</b>	-	TY		
40	* <b>6805 ZZ (5x4)</b>	25	37	7	N2	2,000	90	-	<b>0.69</b>	-	TY		
41	<b>6806 ZZ (5x4)</b>	30	42	7	N2	2,000	90	-	<b>0.98</b>	-	TY		
42	* <b>6807 ZZ</b>	35	47	7	N1	1,500	90	-	<b>1.19</b>	-	TY		
43	<b>6808 ZZ</b>	40	52	7	N1	1,500	90	-	<b>1.71</b>	-	TY		
44	<b>6809 ZZ</b>	45	58	7	N1	700	90	-	<b>2.28</b>	-	TY		
45	* <b>6810 ZZ</b>	50	65	7	N1	700	90	-	<b>2.64</b>	-	TY		
46	* <b>6811 ZZ</b>	55	72	9	N1	500	90	-	<b>3.19</b>	-	TY		
47	<b>6812 ZZ</b>	60	78	10	N1	500	90	-	<b>3.58</b>	-	TY		
48	<b>6813 ZZ</b>	65	85	10	N1	300	90	-	<b>6.50</b>	-	TY		
49	<b>6814 ZZ</b>	70	90	10	N1	300	90	-	<b>7.83</b>	-	TY		
50	<b>6815 ZZ</b>	75	95	10	N1	200	90	-	<b>10.40</b>	-	TY		
51	<b>6816 ZZ</b>	80	100	10	N1	200	90	-	<b>12.54</b>	-	TY		

Remark : 1. Marking on OEM products should all be marked on rubber seals/shields.( Details of marking please refer to the bottom pages "NIKO marking standard").  
2. Exceptional of OEM products, all the other bearings should be marked in workshops.(Details of marking please refer to the bottom pages NIKO marking standard). However,in case the min. order quantity does not meet the production requirement, marking on rubber seals/shields should be accepted.

Remark	Technical supplement		
	Cage(s)	Precision	Grease
	Steel - ✓	Class 0 (JIS)	Alvania S2 -25℃~+120℃
	Polymid - ✗		
	Brass - ✗		

Qualified Sub-contractor(s)	Since
TY	2003
-	-
-	-

**BALL BEARING**  
**SERIES 69**

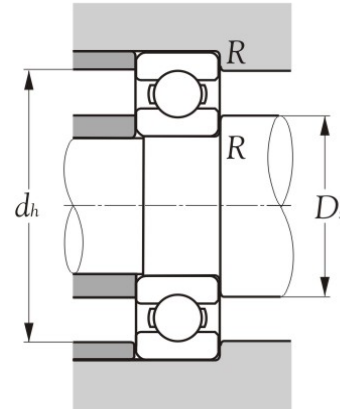
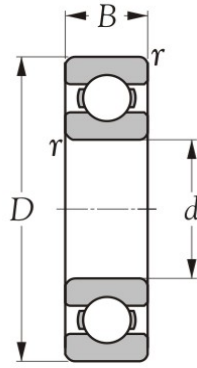

Items (17)	Data  Model nos.	Dimension			Packing method	Quantity  Min. order qty.	Delivery  Days	-		Compare percentages (%)	Production code(s)
		Bearing sizes						Unit price structure	2014-08-01 Unit price structure		
		d	D	B							
		mm				Pcs		USD	USD		
1	6900 (UG) (5x10)	10	22	6	N2	200	90	-	0.35	-	TY
2	6901 (UG) (5x10)	12	24	6	N2	200	90	-	0.38	-	TY
3	6902 (UG) (5x4)	15	28	7	N2	200	90	-	0.48	-	TY
4	6903 (UG) (5x4)	17	30	7	N2	200	90	-	0.51	-	TY
5	6904 (UG) (5x4)	20	37	9	N2	200	90	-	0.60	-	TY
6	6905 (UG) (5x4)	25	42	9	N2	200	90	-	0.73	-	TY
7	6906 (UG) (5x4)	30	47	9	N2	200	90	-	0.94	-	TY
8	* 6907 (UG)	35	55	10	N1	200	90	-	1.08	-	TY
9	6908 (UG)	40	62	12	N1	200	90	-	1.64	-	TY
10	6909 (UG)	45	68	12	N1	200	90	-	2.16	-	TY
11	6910 (UG)	50	72	12	N1	200	90	-	2.41	-	TY
12	6911 (UG)	55	80	13	N1	20	90	-	3.03	-	TY
13	6912 (UG)	60	85	13	N1	20	90	-	3.94	-	TY
14	6913 (UG)	65	90	13	N1	20	90	-	5.48	-	TY
15	6914 (UG)	70	100	16	N1	20	90	-	7.29	-	TY
16	6915 (UG)	75	105	16	N1	20	90	-	9.89	-	TY
17	6916 (UG)	80	110	16	N1	20	90	-	11.74	-	TY

Remark : 1. Marking on OEM products should all be marked on rubber seals/shields.( Details of marking please refer to the bottom pages "NIKO marking standard").  
2. Exceptional of OEM products, all the other bearings should be marked in workshops.(Details of marking please refer to the bottom pages NIKO marking standard). However,in case the min. order quantity does not meet the production requirement, marking on rubber seals/shields should be accepted.

Remark	Technical supplement		
	Cage(s)	Precision	Grease
	Steel - <input checked="" type="checkbox"/> Polymid - <input type="checkbox"/> Brass - <input type="checkbox"/>	Class 0 (JIS)	Nil

Qualified Sub-contractor(s)	Since
TY	2003
-	-
-	-

BALL BEARING

SERIES **69..LLB, 69..ZZ**

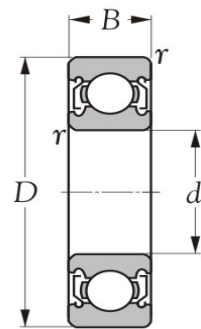

Shielded type (ZZ)



Non-contact sealed type (LLB)

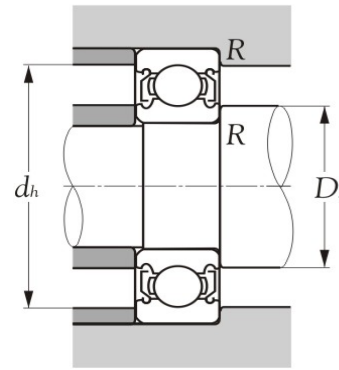

Items (20)	Data Model nos.	Dimension			Packing method	Quantity Min. order qty. Pcs	Delivery Days	-	2014-08-01 Unit price structure USD	Compare percentages (%)	Production code(s)
		Bearing sizes									
		d	D	B							
18	* 6900 LLB (5x10)	10	22	6	N2	2,500	90	-	0.38	-	TY
19	* 6901 LLB (5x10)	12	24	6	N2	2,500	90	-	0.41	-	TY
20	* 6902 LLB (5x4)	15	28	7	N2	1,500	90	-	0.46	-	TY
21	* 6903 LLB (5x4)	17	30	7	N2	1,500	90	-	0.51	-	TY
22	* 6904 LLB (5x4)	20	37	9	N2	1,500	90	-	0.68	-	TY
23	* 6905 LLB (5x4)	25	42	9	N2	1,000	90	-	0.73	-	TY
24	* 6906 LLB (5x4)	30	47	9	N2	1,000	90	-	1.04	-	TY
25	* 6907 LLB	35	55	10	N1	650	90	-	1.19	-	TY
26	* 6908 LLB	40	62	12	N1	650	90	-	1.76	-	TY
27	* 6909 LLB	45	68	12	N1	350	90	-	2.29	-	TY
28	* 6910 LLB	50	72	12	N1	350	90	-	2.64	-	TY
29	* 6911 LLB	55	80	13	N1	250	90	-	3.29	-	TY
30	6912 LLB	60	85	13	N1	250	90	-	4.48	-	TY
31	* 6913 LLB	65	90	13	N1	150	90	-	5.73	-	TY
32	6914 LLB	70	100	16	N1	150	90	-	7.83	-	TY
33	6915 LLB	75	105	16	N1	80	90	-	10.40	-	TY
34	6916 LLB	80	110	16	N1	80	90	-	12.54	-	TY
35	6900 ZZ (5x10)	10	22	6	N2	2,500	90	-	0.38	-	TY
36	6901 ZZ (5x10)	12	24	6	N2	2,500	90	-	0.41	-	TY
37	* 6902 ZZ (5x4)	15	28	7	N2	1,500	90	-	0.46	-	TY

Remark : 1. Marking on OEM products should all be marked on rubber seals/shields.( Details of marking please refer to the bottom pages "NIKO marking standard").  
 2. Exceptional of OEM products, all the other bearings should be marked in workshops.(Details of marking please refer to the bottom pages NIKO marking standard). However,in case the min. order quantity does not meet the production requirement, marking on rubber seals/shields should be accepted.

Remark	Technical supplement		
	Cage(s)	Precision	Grease
	Steel - <input checked="" type="checkbox"/>	Class 0 (JIS)	Alvania S2 -25°C~+120°C
	Polymid - <input checked="" type="checkbox"/>		
	Brass - <input checked="" type="checkbox"/>		

Qualified Sub-contractor(s)	Since
TY	2003
-	-
-	-



BALL BEARING

SERIES **69..LLB, 69..ZZ**

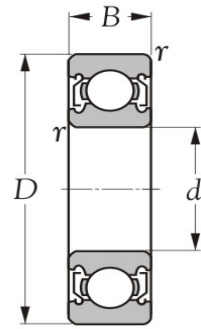

Shielded type (ZZ)



Non-contact sealed type (LLB)

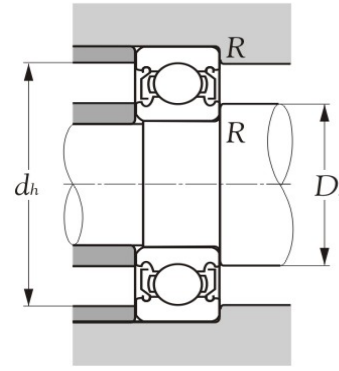

Items (14)	Data Model nos.	Dimension			Packing method	Quantity Min. order qty. Pcs	Delivery Days	-	2014-08-01	Compare percentages (%)	Production code(s)		
		Bearing sizes										Unit price structure USD	Unit price structure USD
		d	D	B									
		mm											
38	6903 ZZ (5x4)	17	30	7	N2	1,500	90	-	0.50	-	TY		
39	6904 ZZ (5x4)	20	37	9	N2	1,500	90	-	0.68	-	TY		
40	6905 ZZ (5x4)	25	42	9	N2	1,000	90	-	0.73	-	TY		
41	6906 ZZ (5x4)	30	47	9	N2	1,000	90	-	0.98	-	TY		
42	6907 ZZ	35	55	10	N1	650	90	-	1.24	-	TY		
43	6908 ZZ	40	62	12	N1	650	90	-	1.84	-	TY		
44	6909 ZZ	45	68	12	N1	350	90	-	2.28	-	TY		
45	6910 ZZ	50	72	12	N1	350	90	-	2.64	-	TY		
46	6911 ZZ	55	80	13	N1	250	90	-	3.19	-	TY		
47	6912 ZZ	60	85	13	N1	250	90	-	4.31	-	TY		
48	6913 ZZ	65	90	13	N1	150	90	-	6.80	-	TY		
49	6914 ZZ	70	100	16	N1	150	90	-	8.40	-	TY		
50	6915 ZZ	75	105	16	N1	80	90	-	10.93	-	TY		
51	6916 ZZ	80	110	16	N1	80	90	-	13.04	-	TY		

Remark : 1. Marking on OEM products should all be marked on rubber seals/shields.( Details of marking please refer to the bottom pages "NIKO marking standard").  
 2. Exceptional of OEM products, all the other bearings should be marked in workshops.(Details of marking please refer to the bottom pages NIKO marking standard). However,in case the min. order quantity does not meet the production requirement, marking on rubber seals/shields should be accepted.

Remark	Technical supplement		
	Cage(s)	Precision	Grease
	Steel - ✓	Class 0 (JIS)	Alvania S2 -25°C~+120°C
	Polymid - ×		
	Brass - ×		

Qualified Sub-contractor(s)	Since
TY	2003
-	-
-	-

**BALL BEARING**  
**SERIES 622..2RS**

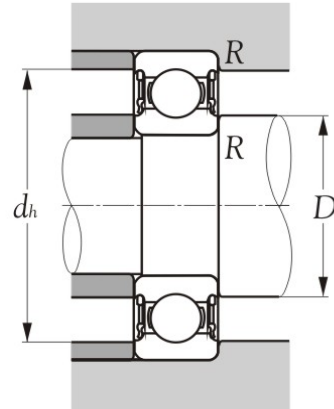
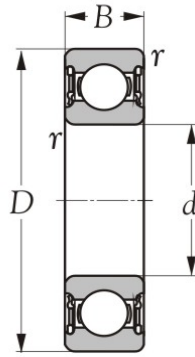

Items (12)	Data  Model nos.	Dimension			Packing method	Quantity  Min. order qty.	Delivery  Days	-	2014-09-01	Compare percentages (%)	Production code(s)
		Bearing sizes						Unit price structure	Unit price structure		
		d	D	B				USD	USD		
mm			Pcs								
1	* 62200 2RS (5x5)	10	30	14	N2	1,500	120	-	1.01	-	CHYX
2	* 62201 2RS (5x5)	12	32	14	N2	1,500	120	-	1.05	-	CHYX
3	* 62202 2RS (5x5)	15	35	14	N2	1,500	120	-	1.18	-	CHYX
4	* 62203 2RS (5x4)	17	40	16	N2	1,250	120	-	1.24	-	CHYX
5	* 62204 2RS (5x2)	20	47	18	N2	1,000	120	-	1.60	-	CHYX
6	* 62205 2RS (5x2)	25	52	18	N2	800	120	-	1.88	-	CHYX
7	* 62206 2RS	30	62	20	N1	600	120	-	2.68	-	CHYX
8	* 62207 2RS	35	72	23	N1	500	120	-	3.09	-	CHYX
9	* 62208 2RS	40	80	23	N1	350	120	-	4.08	-	CHYX
10	* 62209 2RS	45	85	23	N1	250	120	-	5.88	-	CHYX
11	* 62210 2RS	50	90	23	N1	200	120	-	6.55	-	CHYX
12	* 62212 2RS	60	110	28	N1	200	120	-	8.63	-	CHYX

Remark : 1. Marking on OEM products should all be marked on rubber seals/shields.( Details of marking please refer to the bottom pages "NIKO marking standard").  
2. Exceptional of OEM products, all the other bearings should be marked in workshops.(Details of marking please refer to the bottom pages NIKO marking standard). However,in case the min. order quantity does not meet the production requirement, marking on rubber seals/shields should be accepted.

Remark	Technical supplement		
	Cage(s)	Precision	Grease
	Steel - <input checked="" type="checkbox"/>	Class 0 (JIS)	Alvania S2 -25°C~+120°C
	Polymid - <input checked="" type="checkbox"/>		
	Brass - <input checked="" type="checkbox"/>		

Qualified Sub-contractor(s)	Since
CHYX	2008
-	-
-	-

**BALL BEARING**  
**SERIES 623..2RS**

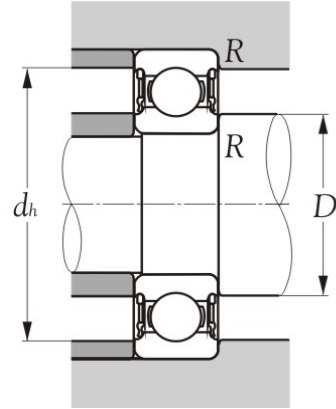
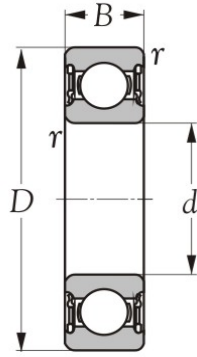

Items (11)	Data  Model nos.	Dimension			Packing method	Quantity  Min. order qty.	Delivery  Days	-	2014-09-01	Compare percentages (%)	Production code(s)
		Bearing sizes						Unit price structure	Unit price structure		
		d	D	B				USD	USD		
mm			Pcs								
1	<b>62300 2RS (5x5)</b>	10	35	17	N2	1,350	120	-	<b>1.38</b>	-	CHYX
2	* <b>62301 2RS (5x5)</b>	12	37	17	N2	1,250	120	-	<b>1.38</b>	-	CHYX
3	* <b>62302 2RS (5x2)</b>	15	42	17	N2	1,000	120	-	<b>1.54</b>	-	CHYX
4	* <b>62303 2RS (5x3)</b>	17	47	19	N2	800	120	-	<b>1.69</b>	-	CHYX
5	* <b>62304 2RS</b>	20	52	21	N1	650	120	-	<b>2.43</b>	-	CHYX
6	* <b>62305 2RS</b>	25	62	24	N1	500	120	-	<b>2.93</b>	-	CHYX
7	* <b>62306 2RS</b>	30	72	27	N1	350	120	-	<b>3.96</b>	-	CHYX
8	* <b>62307 2RS</b>	35	80	31	N1	300	120	-	<b>5.26</b>	-	CHYX
9	* <b>62308 2RS</b>	40	90	33	N1	150	120	-	<b>8.86</b>	-	CHYX
10	<b>62309 2RS</b>	45	100	36	N1	150	120	-	<b>10.68</b>	-	CHYX
11	<b>62310 2RS</b>	50	110	40	N1	150	120	-	<b>9.65</b>	-	CHYX

Remark : 1. Marking on OEM products should all be marked on rubber seals/shields.( Details of marking please refer to the bottom pages "NIKO marking standard").  
2. Exceptional of OEM products, all the other bearings should be marked in workshops.(Details of marking please refer to the bottom pages NIKO marking standard). However,in case the min. order quantity does not meet the production requirement, marking on rubber seals/shields should be accepted.

Remark	Technical supplement		
	Cage(s)	Precision	Grease
	Steel - ✓	Class 0 (JIS)	Alvania S2 -25°C~+120°C
	Polymid - ×		
	Brass - ×		

Qualified Sub-contractor(s)	Since
CHYX	2008
-	-
-	-

**BALL BEARING**  
**SERIES 630..2RS**

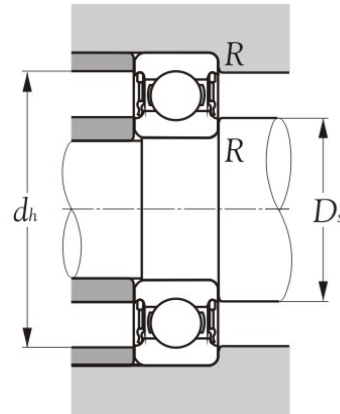
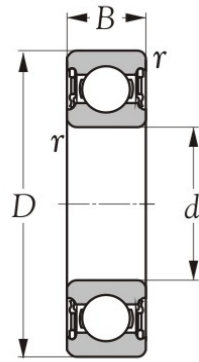

Items (11)	Data  Model nos.	Dimension			Packing method	Quantity  Min. order qty.	Delivery  Days	-	2014-09-01	Compare percentages (%)	Production code(s)
		Bearing sizes						Unit price structure	Unit price structure		
		d	D	B				USD	USD		
		mm				Pcs		USD			
1	<b>63000 2RS (25x1)</b>	10	26	12	N2	750	120	-	<b>0.96</b>	-	CHYX
2	* <b>63001 2RS (25x1)</b>	12	28	12	N2	750	120	-	<b>1.03</b>	-	CHYX
3	* <b>63002 2RS (25x1)</b>	15	32	13	N2	700	120	-	<b>1.20</b>	-	CHYX
4	* <b>63003 2RS (20x1)</b>	17	35	14	N2	600	120	-	<b>1.40</b>	-	CHYX
5	* <b>63004 2RS (10x1)</b>	20	42	16	N2	500	120	-	<b>1.51</b>	-	CHYX
6	* <b>63005 2RS (10x1)</b>	25	47	16	N2	500	120	-	<b>1.76</b>	-	CHYX
7	* <b>63006 2RS</b>	30	55	19	N1	450	120	-	<b>1.80</b>	-	CHYX
8	* <b>63007 2RS</b>	35	62	20	N1	250	120	-	<b>2.93</b>	-	CHYX
9	* <b>63008 2RS</b>	40	68	21	N1	200	120	-	<b>3.63</b>	-	CHYX
10	<b>63009 2RS</b>	45	75	23	N1	200	120	-	<b>3.83</b>	-	CHYX
11	<b>63010 2RS</b>	50	80	23	N1	150	120	-	<b>4.34</b>	-	CHYX

Remark : 1. Marking on OEM products should all be marked on rubber seals/shields.( Details of marking please refer to the bottom pages "NIKO marking standard").  
2. Exceptional of OEM products, all the other bearings should be marked in workshops.(Details of marking please refer to the bottom pages NIKO marking standard). However,in case the min. order quantity does not meet the production requirement, marking on rubber seals/shields should be accepted.

<b>Remark</b>	Technical supplement		
	Cage(s)	Precision	Grease
	Steel - ✓	Class 0 (JIS)	Alvania S2 -25℃~+120℃
	Polymid - ×		
Brass - ×			

Qualified Sub-contractor(s)	Since
CHYX	2008
-	-
-	-

**BALL BEARING**  
**SERIES 64**

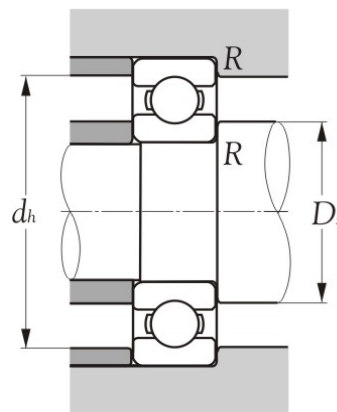
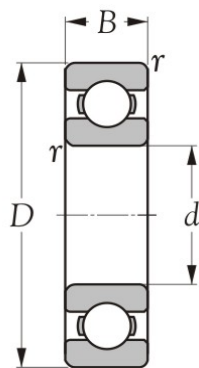

Items (10)	Data  Model nos.	Dimension			Packing method	Quantity  Min. order qty.	Delivery  Days	-	2014-09-01	Compare percentages (%)	Production code(s)
		Bearing sizes						Unit price structure	Unit price structure		
		d	D	B				USD	USD		
mm			Pcs	Days	USD	USD					
1	<b>6403</b>	17	62	17	N1	250	120	-	<b>3.49</b>	-	ZS
2	<b>6404</b>	20	72	19	N1	200	120	-	<b>4.59</b>	-	ZS
3	<b>6405</b>	25	80	21	N1	200	120	-	<b>5.31</b>	-	ZS
4	<b>6406</b>	30	90	23	N1	150	120	-	<b>6.51</b>	-	ZS
5	<b>6407</b>	35	100	25	N1	100	120	-	<b>9.09</b>	-	ZS
6	<b>6408</b>	40	110	27	N1	100	120	-	<b>10.30</b>	-	ZS
7	<b>6409</b>	45	120	29	N1	-	-	-	-	-	-
8	<b>6410</b>	50	130	31	N1	-	-	-	-	-	-
9	<b>6411</b>	55	140	33	N1	-	-	-	-	-	-
10	<b>6412</b>	60	150	35	N1	-	-	-	-	-	-

Remark : 1. Marking on OEM products should all be marked on rubber seals/shields.( Details of marking please refer to the bottom pages "NIKO marking standard").

2. Exceptional of OEM products, all the other bearings should be marked in workshops.(Details of marking please refer to the bottom pages NIKO marking standard). However,in case the min. order quantity does not meet the production requirement, marking on rubber seals/shields should be accepted.

Remark	Technical supplement									
	Cage(s)	Precision	Grease							
	<table border="1"> <tr> <td>Steel -</td> <td>✓</td> </tr> <tr> <td>Polymid -</td> <td>×</td> </tr> <tr> <td>Brass -</td> <td>×</td> </tr> </table>	Steel -	✓	Polymid -	×	Brass -	×	<table border="1"> <tr> <td>Class 0 (JIS)</td> </tr> </table>	Class 0 (JIS)	<table border="1"> <tr> <td>Nil</td> </tr> </table>
Steel -	✓									
Polymid -	×									
Brass -	×									
Class 0 (JIS)										
Nil										

Qualified Sub-contractor(s)	Since
ZS	2004
-	-
-	-

**BALL BEARING**  
**SERIES 52**

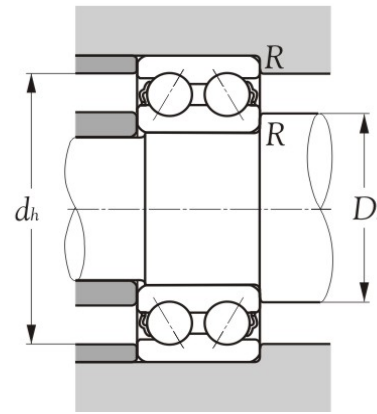
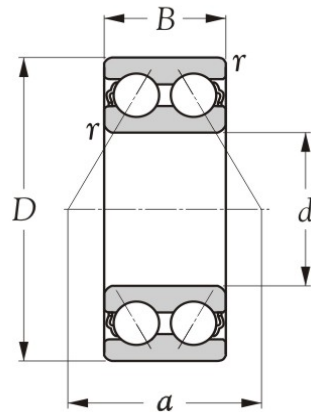

Items (20)	Data  Model nos.	Dimension			Packing method	Quantity  Min. order qty.	Delivery  Days	-	2014-09-01	Compare percentages (%)	Production code(s)		
		Bearing sizes										Unit price structure	Unit price structure
		d	D	B									
		mm				Pcs							
1	5200 (UG) (25x1)	10	30	14.3	N2	50	90	-	2.54	-	FY		
2	5200 A (UG) (25x1)	10	30	14.3	N2	400	90	-	2.29	-	FY		
3	5201 (UG) (25x1)	12	32	15.9	N2	50	90	-	2.73	-	FY		
4	5201 A (UG) (25x1)	12	32	15.9	N2	350	90	-	2.41	-	FY		
5	* 5202 (UG) (25x1)	15	35	15.9	N2	50	90	-	3.00	-	FY		
6	5202 A (UG) (25x1)	15	35	15.9	N2	350	90	-	2.68	-	FY		
7	* 5203 (UG) (10x1)	17	40	17.5	N2	50	90	-	3.20	-	FY		
8	5203 A (UG) (10x1)	17	40	17.5	N2	350	90	-	2.83	-	FY		
9	* 5204 (UG) (10x1)	20	47	20.6	N2	50	90	-	3.36	-	FY		
10	5204 A (UG) (10x1)	20	47	20.6	N2	300	90	-	2.93	-	FY		
11	* 5205 (UG)	25	52	20.6	N1	50	90	-	3.61	-	FY		
12	5205 A (UG)	25	52	20.6	N1	300	90	-	3.26	-	FY		
13	* 5206 (UG)	30	62	23.8	N1	50	90	-	4.26	-	FY		
14	5206 A (UG)	30	62	23.8	N1	200	90	-	4.29	-	FY		
15	* 5207 (UG)	35	72	27	N1	50	90	-	5.28	-	FY		
16	5207 A (UG)	35	72	27	N1	200	90	-	4.99	-	FY		
17	* 5208 (UG)	40	80	30.2	N1	50	90	-	6.34	-	FY		
18	5208 A (UG)	40	80	30.2	N1	150	90	-	5.98	-	FY		
19	* 5209 (UG)	45	85	30.2	N1	50	90	-	7.69	-	FY		
20	5209 A (UG)	45	85	30.2	N1	150	90	-	7.23	-	FY		

Remark : 1. Marking on OEM products should all be marked on rubber seals/shields.( Details of marking please refer to the bottom pages "NIKO marking standard").  
2. Exceptional of OEM products, all the other bearings should be marked in workshops.(Details of marking please refer to the bottom pages NIKO marking standard). However,in case the min. order quantity does not meet the production requirement, marking on rubber seals/shields should be accepted.

Remark	Technical supplement		
	Cage(s)	Precision	Grease
	Steel - <input checked="" type="checkbox"/>	Class 0 (JIS)	Nil
	Polymid - <input type="checkbox"/>		
	Brass - <input checked="" type="checkbox"/>		

Qualified Sub-contractor(s)	Since
FY	2005
-	-
-	-

**BALL BEARING**  
**SERIES 52..2RS**

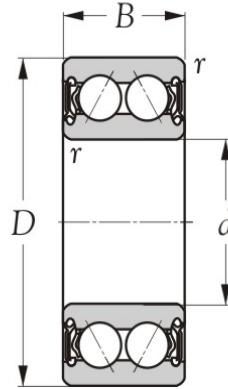

Items (20)	Data  Model nos.	Dimension			Packing method	Quantity  Min. order qty.  Pcs	Delivery  Days	-	2014-09-01	Compare percentages (%)	Production code(s)		
		Bearing sizes										Unit price structure  USD	Unit price structure  USD
		d	D	B									
		mm											
21	* 5210 (UG)	50	90	30.2	N1	50	90	-	9.65	-	FY		
22	5210 A (UG)	50	90	30.2	N1	130	90	-	8.16	-	FY		
23	* 5200 2RS (25x1)	10	30	14.3	N2	500	90	-	2.73	-	FY		
24	5200 A 2RS (25x1)	10	30	14.3	N2	-	-	-	-	-	-		
25	* 5201 2RS (25x1)	12	32	15.9	N2	450	90	-	2.99	-	FY		
26	5201 A 2RS (25x1)	12	32	15.9	N2	350	90	-	2.56	-	FY		
27	* 5202 2RS (25x1)	15	35	15.9	N2	400	90	-	3.20	-	FY		
28	5202 A 2RS (25x1)	15	35	15.9	N2	300	90	-	2.69	-	FY		
29	* 5203 2RS (10x1)	17	40	17.5	N2	400	90	-	3.36	-	FY		
30	5203 A 2RS (10x1)	17	40	17.5	N2	300	90	-	2.99	-	FY		
31	* 5204 2RS (10x1)	20	47	20.6	N2	350	90	-	3.61	-	FY		
32	5204 A 2RS (10x1)	20	47	20.6	N2	300	90	-	3.20	-	FY		
33	* 5205 2RS	25	52	20.6	N1	350	90	-	3.75	-	FY		
34	5205 A 2RS	25	52	20.6	N1	250	90	-	3.30	-	FY		
35	* 5206 2RS	30	62	23.8	N1	300	90	-	4.55	-	FY		
36	5206 A 2RS	30	62	23.8	N1	200	90	-	4.49	-	FY		
37	* 5207 2RS	35	72	27	N1	250	90	-	5.40	-	FY		
38	5207 A 2RS	35	72	27	N1	150	90	-	5.45	-	FY		
39	* 5208 2RS	40	80	30.2	N1	200	90	-	6.95	-	FY		
40	5208 A 2RS	40	80	30.2	N1	150	90	-	6.56	-	FY		

Remark : 1. Marking on OEM products should all be marked on rubber seals/shields.( Details of marking please refer to the bottom pages "NIKO marking standard").  
2. Exceptional of OEM products, all the other bearings should be marked in workshops.(Details of marking please refer to the bottom pages NIKO marking standard). However,in case the min. order quantity does not meet the production requirement, marking on rubber seals/shields should be accepted.

Remark	Technical supplement		
	Cage(s)	Precision	Grease
	Steel - <input checked="" type="checkbox"/>	Class 0 (JIS)	Alvania S2 -25°C~+120°C
	Polymid - <input type="checkbox"/>		
	Brass - <input checked="" type="checkbox"/>		

Qualified Sub-contractor(s)	Since
FY	2005
-	-
-	-

**BALL BEARING**  
**SERIES 52..2RS**

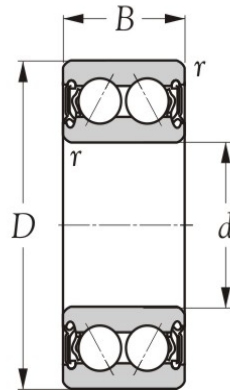

Items (2)	Data  Model nos.	Dimension			Packing method	Quantity  Min. order qty.	Delivery  Days	-		2014-09-01  Unit price structure	Compare percentages (%)	Production code(s)
		Bearing sizes						Unit price structure	Unit price structure			
		d	D	B								
		mm				Pcs		USD	USD			
41	* 5209 2RS	45	85	30.2	N1	150	90	-	8.36	-	FY	
42	5209 A 2RS	45	85	30.2	N1	150	90	-	8.00	-	FY	

Remark : 1. Marking on OEM products should all be marked on rubber seals/shields.( Details of marking please refer to the bottom pages "NIKO marking standard").  
 2. Exceptional of OEM products, all the other bearings should be marked in workshops.(Details of marking please refer to the bottom pages NIKO marking standard). However,in case the min. order quantity does not meet the production requirement, marking on rubber seals/shields should be accepted.

Remark	Technical supplement		
	Cage(s)	Precision	Grease
	Steel - <input checked="" type="checkbox"/>	Class 0 (JIS)	Alvania S2 -25°C~+120°C
	Polymid - <input checked="" type="checkbox"/>		
	Brass - <input checked="" type="checkbox"/>		

Qualified Sub-contractor(s)	Since
FY	2005
-	-
-	-



**BALL BEARING**  
**SERIES 53**

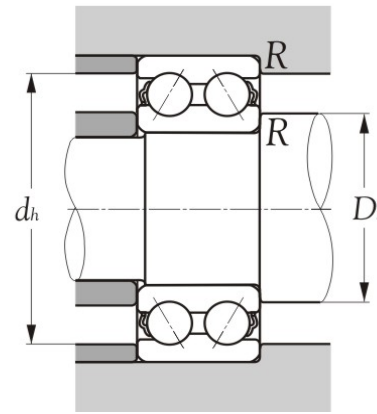
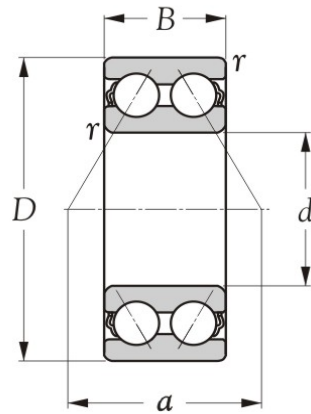

Items (18)	Data  Model nos.	Dimension			Packing method	Quantity  Min. order qty.	Delivery  Days	-	2014-09-01	Compare percentages (%)	Production code(s)		
		Bearing sizes										Unit price structure	Unit price structure
		d	D	B									
		mm				Pcs							
1	5302 (UG)	15	42	19	N1	50	90	-	3.00	-	FY		
2	5302 A (UG)	15	42	19	N1	350	90	-	2.66	-	FY		
3	5303 (UG)	17	47	22.2	N1	50	90	-	3.41	-	FY		
4	5303 A (UG)	17	47	22.2	N1	300	90	-	3.14	-	FY		
5	* 5304 (UG)	20	52	22.2	N1	50	90	-	3.81	-	FY		
6	5304 A (UG)	20	52	22.2	N1	250	90	-	3.56	-	FY		
7	5305 (UG)	25	62	25.4	N1	50	90	-	4.76	-	FY		
8	5305 A (UG)	25	62	25.4	N1	200	90	-	4.55	-	FY		
9	* 5306 (UG)	30	72	30.2	N1	50	90	-	5.81	-	FY		
10	5306 A (UG)	30	72	30.2	N1	150	90	-	5.64	-	FY		
11	5307 (UG)	35	80	34.9	N1	50	90	-	7.69	-	FY		
12	5307 A (UG)	35	80	34.9	N1	150	90	-	7.61	-	FY		
13	5308 (UG)	40	90	36.5	N1	50	90	-	10.10	-	FY		
14	5308 A (UG)	40	90	36.5	N1	100	90	-	10.21	-	FY		
15	5309 (UG)	45	100	39.7	N1	50	90	-	12.89	-	FY		
16	5309 A (UG)	45	100	39.7	N1	100	90	-	12.46	-	FY		
17	5310 (UG)	50	110	44.4	N1	50	90	-	20.38	-	FY		
18	5310 A (UG)	50	110	44.4	N1	80	90	-	20.16	-	FY		

Remark : 1. Marking on OEM products should all be marked on rubber seals/shields.( Details of marking please refer to the bottom pages "NIKO marking standard").  
2. Exceptional of OEM products, all the other bearings should be marked in workshops.(Details of marking please refer to the bottom pages NIKO marking standard). However,in case the min. order quantity does not meet the production requirement, marking on rubber seals/shields should be accepted.

Remark	Technical supplement		
	Cage(s)	Precision	Grease
	Steel - ✓	Class 0 (JIS)	Nil
	Polymid - A		
	Brass - X		

Qualified Sub-contractor(s)	Since
FY	2005
-	-
-	-

**BALL BEARING**  
**SERIES 53..2RS**

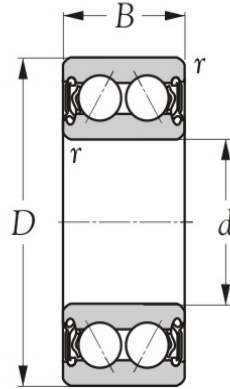

Items (14)	Data  Model nos.	Dimension			Packing method	Quantity  Min. order qty.  Pcs	Delivery  Days	-	2014-09-01	Compare percentages (%)	Production code(s)		
		Bearing sizes										Unit price structure  USD	Unit price structure  USD
		d	D	B									
		mm											
19	5302 2RS	15	42	19	N1	200	90	-	3.31	-	FY		
20	5302 A 2RS	15	42	19	N1	250	90	-	2.89	-	FY		
21	* 5303 2RS	17	47	22.2	N1	200	90	-	3.56	-	FY		
22	5303 A 2RS	17	47	22.2	N1	225	90	-	3.26	-	FY		
23	* 5304 2RS	20	52	22.2	N1	200	90	-	3.98	-	FY		
24	5304 A 2RS	20	52	22.2	N1	200	90	-	3.78	-	FY		
25	5305 2RS	25	62	25.4	N1	150	90	-	4.99	-	FY		
26	5305 A 2RS	25	62	25.4	N1	175	90	-	4.76	-	FY		
27	5306 2RS	30	72	30.2	N1	120	90	-	6.10	-	FY		
28	5306 A 2RS	30	72	30.2	N1	150	90	-	5.98	-	FY		
29	5307 2RS	35	80	34.9	N1	100	90	-	8.06	-	FY		
30	5307 A 2RS	35	80	34.9	N1	150	90	-	7.98	-	FY		
31	5308 2RS	40	90	36.5	N1	80	90	-	10.69	-	FY		
32	5308 A 2RS	40	90	36.5	N1	100	90	-	10.68	-	FY		
33	5309 2RS	45	100	39.7	N1	50	90	-	13.39	-	FY		
34	5309 A 2RS	45	100	39.7	N1	100	90	-	12.78	-	FY		

Remark : 1. Marking on OEM products should all be marked on rubber seals/shields.( Details of marking please refer to the bottom pages "NIKO marking standard").  
2. Exceptional of OEM products, all the other bearings should be marked in workshops.(Details of marking please refer to the bottom pages NIKO marking standard). However,in case the min. order quantity does not meet the production requirement, marking on rubber seals/shields should be accepted.

Remark	Technical supplement		
	Cage(s)	Precision	Grease
	Steel - ✓	Class 0 (JIS)	Alvania S2 -25°C~+120°C
	Polymid - A		
	Brass - X		

Qualified Sub-contractor(s)	Since
FY	2005
-	-
-	-

**BALL BEARING**  
**SERIES 12,12..K**

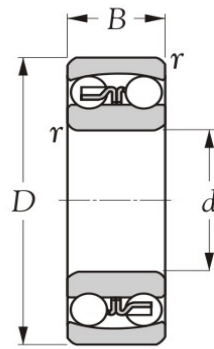

Cylindrical bore

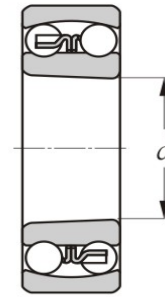

Tapered bore  
taper 1:12

Items (20)	Data  Model nos.	Dimension			Packing method	Quantity  Min. order qty.  Pcs	Delivery  Days	-	2014-09-01	Compare percentages (%)	Production code(s)		
		Bearing sizes										Unit price structure  USD	Unit price structure  USD
		d	D	B									
		mm											
1	<b>1200 E</b>	10	30	9	N1	350	90	-	<b>1.08</b>	-	ZS		
2	<b>1201 E</b>	12	32	10	N1	350	90	-	<b>1.15</b>	-	ZS		
3	<b>1202 E</b>	15	35	11	N1	300	90	-	<b>1.25</b>	-	ZS		
4	* <b>1203 E</b>	17	40	12	N1	250	90	-	<b>1.51</b>	-	ZS		
5	<b>1204</b>	20	47	14	N1	200	90	-	<b>1.85</b>	-	ZS		
6	<b>1205</b>	25	52	15	N1	200	90	-	<b>1.96</b>	-	ZS		
7	<b>1206</b>	30	62	16	N1	180	90	-	<b>2.13</b>	-	ZS		
8	* <b>1207</b>	35	72	17	N1	150	90	-	<b>2.53</b>	-	ZS		
9	<b>1208</b>	40	80	18	N1	120	90	-	<b>3.26</b>	-	ZS		
10	<b>1209</b>	45	85	19	N1	100	90	-	<b>3.55</b>	-	ZS		
11	<b>1210</b>	50	90	20	N1	100	90	-	<b>3.80</b>	-	ZS		
12	<b>1211</b>	55	100	21	N1	80	90	-	<b>4.79</b>	-	ZS		
13	<b>1212</b>	60	110	22	N1	70	90	-	<b>5.69</b>	-	ZS		
14	<b>1213</b>	65	120	23	N1	50	90	-	<b>7.05</b>	-	ZS		
15	<b>1214</b>	70	125	24	N1	40	90	-	<b>8.91</b>	-	ZS		
16	<b>1215</b>	75	130	25	N1	40	90	-	<b>9.58</b>	-	ZS		
17	<b>1216</b>	80	140	26	N1	-	-	-	-	-	-		
18	<b>1204 K</b>	20	47	14	N1	200	90	-	<b>1.88</b>	-	ZS		
19	<b>1205 K</b>	25	52	15	N1	180	90	-	<b>2.06</b>	-	ZS		
20	<b>1206 K</b>	30	62	16	N1	160	90	-	<b>2.21</b>	-	ZS		

Remark	Technical supplement		
	Cage(s)	Precision	Grease
	Steel - <input checked="" type="checkbox"/>	Class 0 (JIS)	Nil
	Polymid - <input checked="" type="checkbox"/>		
Brass - <input checked="" type="checkbox"/>			

Qualified Sub-contractor(s)	Since
ZS	2005
-	-
-	-

**BALL BEARING**  
**SERIES 12, 12..K**

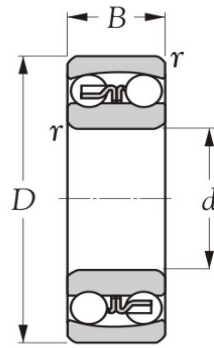

Cylindrical bore

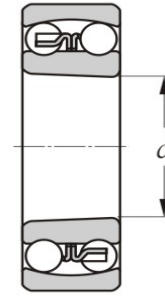

Tapered bore  
taper 1:12

Items (9)	Data  Model nos.	Dimension			Packing method	Quantity  Min. order qty.  Pcs	Delivery  Days	-	2014-09-01	Compare percentages (%)	Production code(s)		
		Bearing sizes										Unit price structure  USD	Unit price structure  USD
		d	D	B									
		mm											
21	<b>1207 K</b>	35	72	17	N1	150	90	-	<b>2.58</b>	-	ZS		
22	<b>1208 K</b>	40	80	18	N1	120	90	-	<b>3.26</b>	-	TZ		
23	<b>1209 K</b>	45	85	19	N1	100	90	-	<b>3.63</b>	-	TZ		
24	<b>1210 K</b>	50	90	20	N1	100	90	-	<b>4.01</b>	-	TZ		
25	<b>1211 K</b>	55	100	21	N1	80	90	-	<b>4.91</b>	-	TZ		
26	<b>1212 K</b>	60	110	22	N1	65	90	-	<b>5.76</b>	-	TZ		
27	<b>1213 K</b>	65	120	23	N1	50	90	-	<b>7.16</b>	-	TZ		
28	<b>1215 K</b>	75	130	25	N1	40	90	-	<b>9.71</b>	-	TZ		
29	<b>1216 K</b>	80	140	26	N1	-	-	-	-	-	-		

Remark	Technical supplement		
	Cage(s)	Precision	Grease
	Steel - <input checked="" type="checkbox"/> Polymid - <input type="checkbox"/> E Brass - <input checked="" type="checkbox"/>	Class 0 (JIS)	Nil

Qualified Sub-contractor(s)	Since
ZS	2005
TZ	2004
-	-

**BALL BEARING**  
**SERIES 13,13..K**

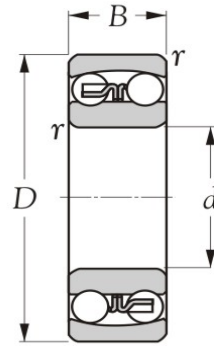

Cylindrical bore

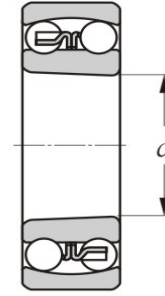

Tapered bore  
taper 1:12

Items (22)	Data  Model nos.	Dimension			Packing method	Quantity  Min. order qty.  Pcs	Delivery  Days	-	2014-09-01	Compare percentages (%)	Production code(s)		
		Bearing sizes										Unit price structure  USD	Unit price structure  USD
		d	D	B									
		mm											
1	1300 E	10	35	11	N1	120	90	-	1.88	-	ZS		
2	1301 E	12	37	12	N1	120	90	-	1.90	-	ZS		
3	1302 E	15	42	13	N1	100	90	-	2.08	-	ZS		
4	1303 E	17	47	14	N1	100	90	-	2.21	-	ZS		
5	1304	20	52	15	N1	90	90	-	2.59	-	ZS		
6	1305	25	62	17	N1	80	90	-	2.83	-	ZS		
7	1306	30	72	19	N1	70	90	-	3.26	-	ZS		
8	1307	35	80	21	N1	50	90	-	4.19	-	ZS		
9	1308	40	90	23	N1	40	90	-	5.21	-	ZS		
10	1309	45	100	25	N1	35	90	-	6.70	-	ZS		
11	* 1310	50	110	27	N1	30	90	-	7.99	-	ZS		
12	1311	55	120	29	N1	25	90	-	9.33	-	ZS		
13	1312	60	130	31	N1	20	90	-	12.65	-	ZS		
14	1304 K	20	52	15	N1	85	90	-	2.68	-	ZS		
15	1305 K	25	62	17	N1	80	90	-	2.85	-	ZS		
16	1306 K	30	72	19	N1	70	90	-	3.26	-	ZS		
17	1307 K	35	80	21	N1	50	90	-	4.29	-	ZS		
18	1308 K	40	90	23	N1	40	90	-	5.35	-	ZS		
19	1309 K	45	100	25	N1	30	90	-	6.88	-	ZS		
20	1310 K	50	110	27	N1	30	90	-	8.21	-	ZS		
21	1311 K	55	120	29	N1	25	90	-	9.65	-	ZS		
22	1312 K	60	130	31	N1	20	90	-	12.65	-	ZS		

<b>Remark</b>	Technical supplement		
	Cage(s)	Precision	Grease
	Steel - <input checked="" type="checkbox"/>	Class 0 (JIS)	Nil
	Polymid - <input type="checkbox"/> E		
Brass - <input checked="" type="checkbox"/> X			

Qualified Sub-contractor(s)	Since
ZS	2005
-	-
-	-

**BALL BEARING**  
**SERIES 22, 22..K**

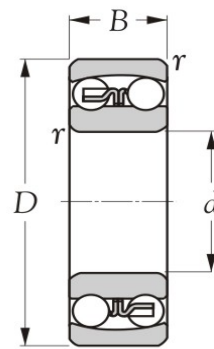

Cylindrical bore

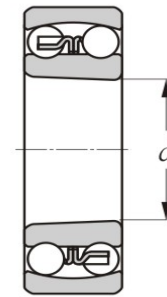

Tapered bore  
taper 1:12

Items (22)	Data  Model nos.	Dimension			Packing method	Quantity  Min. order qty.  Pcs	Delivery  Days	-	2014-09-01	Compare percentages (%)	Production code(s)		
		Bearing sizes										Unit price structure  USD	Unit price structure  USD
		d	D	B									
		mm											
1	2200 E	10	30	14	N1	200	90	-	1.59	-	ZS		
2	2201 E	12	32	14	N1	200	90	-	1.64	-	ZS		
3	2202	15	35	14	N1	200	90	-	1.64	-	ZS		
4	2203	17	40	16	N1	180	90	-	1.95	-	ZS		
5	2204	20	47	18	N1	140	90	-	2.44	-	ZS		
6	2205	25	52	18	N1	125	90	-	2.44	-	ZS		
7	2206	30	62	20	N1	100	90	-	3.40	-	ZS		
8	2207	35	72	23	N1	80	90	-	4.31	-	ZS		
9	2208	40	80	23	N1	70	90	-	4.90	-	ZS		
10	2209	45	85	23	N1	60	90	-	6.14	-	ZS		
11	2210	50	90	23	N1	50	90	-	6.85	-	ZS		
12	2211	55	100	25	N1	40	90	-	8.25	-	ZS		
13	2212	60	110	28	N1	30	90	-	11.30	-	ZS		
14	2204 K	20	47	18	N1	140	90	-	2.51	-	ZS		
15	2205 K	25	52	18	N1	120	90	-	2.51	-	ZS		
16	2206 K	30	62	20	N1	100	90	-	3.58	-	ZS		
17	2207 K	35	72	23	N1	80	90	-	4.58	-	ZS		
18	2208 K	40	80	23	N1	70	90	-	5.21	-	ZS		
19	2209 K	45	85	23	N1	50	90	-	6.45	-	ZS		
20	2210 K	50	90	23	N1	50	90	-	7.18	-	ZS		
21	2211 K	55	100	25	N1	40	90	-	8.55	-	ZS		
22	2212 K	60	110	28	N1	30	90	-	12.00	-	ZS		

Remark : 1. Marking on OEM products should all be marked on rubber seals/shields.( Details of marking please refer to the bottom pages "NIKO marking standard").  
2. Exceptional of OEM products, all the other bearings should be marked in workshops.(Details of marking please refer to the bottom pages NIKO marking standard). However,in case the min. order quantity does not meet the production requirement, marking on rubber seals/shields should be accepted.

Remark	Technical supplement		
	Cage(s)	Precision	Grease
	Steel - <input checked="" type="checkbox"/>	Class 0 (JIS)	Nil
	Polymid - <input type="checkbox"/>		
	Brass - <input checked="" type="checkbox"/>		

Qualified Sub-contractor(s)	Since
ZS	2005
-	-
-	-

**BALL BEARING**  
**SERIES 22..2RS**

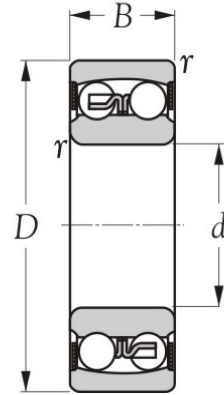

Items (15)	Data  Model nos.	Dimension			Packing method	Quantity  Min. order qty.	Delivery  Days	-	2014-09-01	Compare percentages (%)	Production code(s)
		Bearing sizes						Unit price structure	Unit price structure		
		d	D	B				USD	USD		
mm			Pcs								
23	* 2200 E 2RS	10	30	14	N1	200	90	-	1.70	-	ZS
24	* 2201 E 2RS	12	32	14	N1	200	90	-	1.66	-	ZS
25	* 2202 2RS	15	35	14	N1	180	90	-	1.88	-	ZS
26	* 2203 2RS	17	40	16	N1	150	90	-	2.23	-	ZS
27	* 2204 2RS	20	47	18	N1	140	90	-	2.53	-	ZS
28	* 2205 2RS	25	52	18	N1	120	90	-	2.69	-	ZS
29	* 2206 2RS	30	62	20	N1	100	90	-	3.51	-	ZS
30	* 2207 2RS	35	72	23	N1	80	90	-	4.58	-	ZS
31	* 2208 2RS	40	80	23	N1	70	90	-	5.30	-	ZS
32	* 2209 2RS	45	85	23	N1	50	90	-	6.66	-	ZS
33	* 2210 2RS	50	90	23	N1	40	90	-	7.78	-	ZS
34	* 2211 2RS	55	100	25	N1	40	90	-	8.83	-	ZS
35	2212 2RS	60	110	28	N1	40	90	-	13.75	-	ZS

Remark : 1. Marking on OEM products should all be marked on rubber seals/shields.( Details of marking please refer to the bottom pages "NIKO marking standard").  
2. Exceptional of OEM products, all the other bearings should be marked in workshops.(Details of marking please refer to the bottom pages NIKO marking standard). However,in case the min. order quantity does not meet the production requirement, marking on rubber seals/shields should be accepted.

Remark	Technical supplement		
	Cage(s)	Precision	Grease
	Steel - ✓	Class 0 (JIS)	Alvania S2 -25°C~+120°C
	Polymid - E		
	Brass - X		

Qualified Sub-contractor(s)	Since
ZS	2005
-	-
-	-

**BALL BEARING**  
**SERIES 23, 23..K**

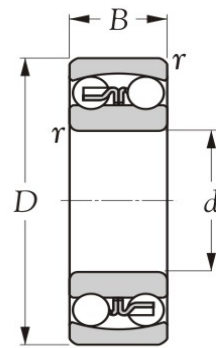

Cylindrical bore

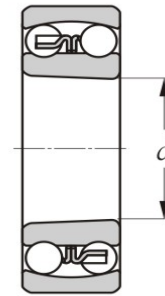

Tapered bore  
taper 1:12

Items (22)	Data  Model nos.	Dimension			Packing method	Quantity  Min. order qty.  Pcs	Delivery  Days	-	2014-09-01	Compare percentages (%)	Production code(s)		
		Bearing sizes										Unit price structure  USD	Unit price structure  USD
		d	D	B									
		mm											
1	2300 E	10	35	17	N1	80	90	-	2.63	-	ZS		
2	2301 E	12	37	17	N1	70	90	-	2.78	-	ZS		
3	2302	15	42	17	N1	70	90	-	2.73	-	ZS		
4	2303	17	47	19	N1	70	90	-	3.11	-	ZS		
5	2304	20	52	21	N1	50	90	-	3.83	-	ZS		
6	2305	25	62	24	N1	40	90	-	4.64	-	ZS		
7	2306	30	72	27	N1	40	90	-	5.74	-	ZS		
8	2307	35	80	31	N1	30	90	-	7.23	-	ZS		
9	2308	40	90	33	N1	-	-	-	-	-	-		
10	2309	45	100	36	N1	-	-	-	-	-	-		
11	2310	50	110	40	N1	-	-	-	-	-	-		
12	2311	55	120	43	N1	-	-	-	-	-	-		
13	2312	60	130	46	N1	-	-	-	-	-	-		
14	2304 K	20	52	21	N1	50	90	-	4.03	-	ZS		
15	2305 K	25	62	24	N1	40	90	-	5.09	-	ZS		
16	2306 K	30	72	27	N1	30	90	-	6.05	-	ZS		
17	2307 K	35	80	31	N1	30	90	-	7.49	-	ZS		
18	2308 K	40	90	33	N1	-	-	-	-	-	-		
19	2309 K	45	100	36	N1	-	-	-	-	-	-		
20	2310 K	50	110	40	N1	-	-	-	-	-	-		
21	2311 K	55	120	43	N1	-	-	-	-	-	-		
22	2312 K	60	130	46	N1	-	-	-	-	-	-		

Remark : 1. Marking on OEM products should all be marked on rubber seals/shields.( Details of marking please refer to the bottom pages "NIKO marking standard").  
2. Exceptional of OEM products, all the other bearings should be marked in workshops.(Details of marking please refer to the bottom pages NIKO marking standard). However, in case the min. order quantity does not meet the production requirement, marking on rubber seals/shields should be accepted.

Remark	Technical supplement		
	Cage(s)	Precision	Grease
	Steel - <input checked="" type="checkbox"/> Polymid - <input type="checkbox"/> E Brass - <input checked="" type="checkbox"/>	Class 0 (JIS)	Nil

Qualified Sub-contractor(s)	Since
ZS	2005
-	-
-	-



**BALL BEARING**  
**SERIES 23..2RS**

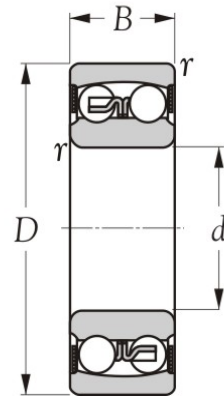

Items (9)	Data  Model nos.	Dimension			Packing method	Quantity  Min. order qty.  Pcs	Delivery  Days	-	2014-09-01	Compare percentages (%)	Production code(s)		
		Bearing sizes										Unit price structure  USD	Unit price structure  USD
		d	D	B									
		mm											
23	<b>2302 2RS</b>	15	42	17	N1	90	90	-	<b>2.34</b>	-	ZS		
24	* <b>2303 2RS</b>	17	47	19	N1	80	90	-	<b>2.64</b>	-	ZS		
25	<b>2304 2RS</b>	20	52	21	N1	70	90	-	<b>3.16</b>	-	ZS		
26	<b>2305 2RS</b>	25	62	24	N1	60	90	-	<b>3.71</b>	-	ZS		
27	<b>2306 2RS</b>	30	72	27	N1	50	90	-	<b>4.45</b>	-	ZS		
28	<b>2307 2RS</b>	35	80	31	N1	30	90	-	<b>6.25</b>	-	ZS		
29	<b>2308 2RS</b>	40	90	33	N1	-	-	-	-	-	-		
30	<b>2309 2RS</b>	45	100	36	N1	-	-	-	-	-	-		
31	<b>2310 2RS</b>	50	110	40	N1	-	-	-	-	-	-		

Remark : 1. Marking on OEM products should all be marked on rubber seals/shields.( Details of marking please refer to the bottom pages "NIKO marking standard").  
 2. Exceptional of OEM products, all the other bearings should be marked in workshops.(Details of marking please refer to the bottom pages NIKO marking standard). However,in case the min. order quantity does not meet the production requirement, marking on rubber seals/shields should be accepted.

Remark	Technical supplement		
	Cage(s)	Precision	Grease
	Steel - ✓	Class 0 (JIS)	Alvania S2 -25°C~+120°C
	Polymid - E		
	Brass - X		

Qualified Sub-contractor(s)	Since
ZS	2005
-	-
-	-

**STAINLESS STEEL BALL BEARINGS**  
**SERIES S 60.. 2RS**

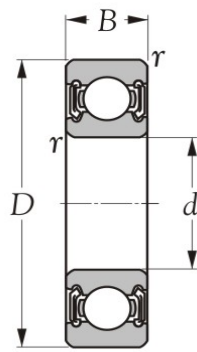

Non-contact sealed type (2RS)

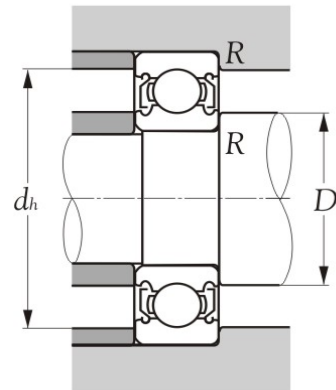

Items (14)	Data Model nos.	Dimension			Packing method	Quantity Min. order qty. Pcs	Delivery Days	-		Compare percentages (%)	Production code(s)
		Bearing sizes						Unit price structure USD	2014-09-01 Unit price structure USD		
		d	D	B							
		mm									
1	S 6000 2RS (10x1)	10	26	8	N2	1,500	90	-	1.10	-	ZHXJ
2	S 6001 2RS (10x1)	12	28	8	N2	1,400	90	-	1.19	-	ZHXJ
3	S 6002 2RS (5x1)	15	32	9	N2	1,200	90	-	1.49	-	ZHXJ
4	S 6003 2RS	17	35	10	N1	1,000	90	-	1.80	-	ZHXJ
5	S 6004 2RS	20	42	12	N1	800	90	-	2.18	-	ZHXJ
6	S 6005 2RS	25	47	12	N1	700	90	-	2.49	-	ZHXJ
7	S 6006 2RS	30	55	13	N1	500	90	-	3.88	-	ZHXJ
8	S 6007 2RS	35	62	14	N1	400	90	-	4.95	-	ZHXJ
9	S 6008 2RS	40	68	15	N1	300	90	-	6.20	-	ZHXJ
10	S 6009 2RS	45	75	16	N1	250	90	-	7.75	-	ZHXJ
11	S 6010 2RS	50	80	16	N1	200	90	-	9.29	-	ZHXJ
12	S 6011 2RS	55	90	18	N1	150	90	-	12.39	-	ZHXJ
13	S 6012 2RS	60	95	18	N1	150	90	-	15.51	-	ZHXJ
14	S 6013 2RS	65	100	18	N1	100	90	-	21.70	-	ZHXJ

Remark : 1. Marking on OEM products should all be marked on rubber seals/shields.( Details of marking please refer to the bottom pages "NIKO marking standard").

2. Exceptional of OEM products, all the other bearings should be marked in workshops.(Details of marking please refer to the bottom pages NIKO marking standard). However,in case the min. order quantity does not meet the production requirement, marking on rubber seals/shields should be accepted.

Remark	Technical supplement		
	Cage(s)	Precision	Grease
	Steel - ✓	Class 0 (JIS)	Alvania S2 -25°C~+120°C
	Polymid - ✗		
	Brass - ✗		

Qualified Sub-contractor(s)	Since
ZHXJ	2008
-	-
-	-

**STAINLESS STEEL BALL BEARINGS**  
**SERIES S 62.. 2RS**

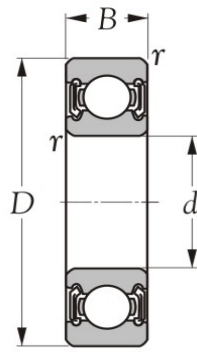

Non-contact sealed type (2RS)

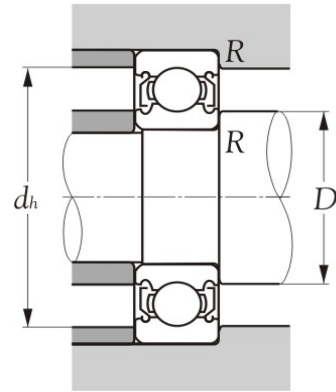

Items (11)	Data Model nos.	Dimension			Packing method	Quantity Min. order qty. Pcs	Delivery Days	-		Compare percentages (%)	Production code(s)
		Bearing sizes						Unit price structure USD	2014-09-01 Unit price structure USD		
		d	D	B							
		mm									
1	S 6200 2RS (5x1)	10	30	9	N2	1,300	90	-	1.30	-	ZHXJ
2	S 6201 2RS (5x1)	12	32	10	N2	1,100	90	-	1.54	-	ZHXJ
3	S 6202 2RS	15	35	11	N1	900	90	-	1.86	-	ZHXJ
4	S 6203 2RS	17	40	12	N1	800	90	-	2.33	-	ZHXJ
5	S 6204 2RS	20	47	14	N1	600	90	-	2.95	-	ZHXJ
6	S 6205 2RS	25	52	15	N1	500	90	-	3.88	-	ZHXJ
7	S 6206 2RS	30	62	16	N1	400	90	-	5.14	-	ZHXJ
8	S 6207 2RS	35	72	17	N1	250	90	-	7.44	-	ZHXJ
9	S 6208 2RS	40	80	18	N1	200	90	-	9.91	-	ZHXJ
10	S 6209 2RS	45	85	19	N1	150	90	-	12.39	-	ZHXJ
11	S 6210 2RS	50	90	20	N1	120	90	-	14.89	-	ZHXJ

Remark : 1. Marking on OEM products should all be marked on rubber seals/shields.( Details of marking please refer to the bottom pages "NIKO marking standard").  
2. Exceptional of OEM products, all the other bearings should be marked in workshops.(Details of marking please refer to the bottom pages NIKO marking standard). However,in case the min. order quantity does not meet the production requirement, marking on rubber seals/shields should be accepted.

Remark	Technical supplement		
	Cage(s)	Precision	Grease
	Steel - ✓	Class 0 (JIS)	Alvania S2 -25°C~+120°C
	Polymid - ✗		
	Brass - ✗		

Qualified Sub-contractor(s)	Since
ZHXJ	2008
-	-
-	-



# TAPER ROLLER BEARINGS



**TAPER ROLLER BEARING**  
**SERIES 302**

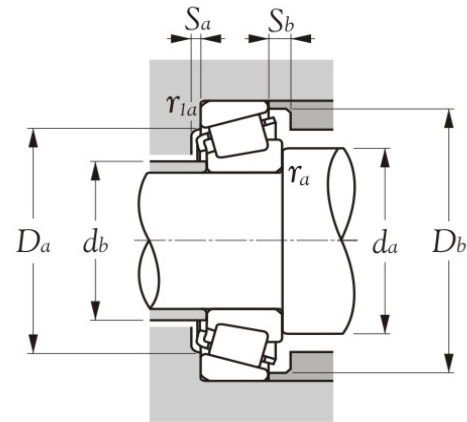
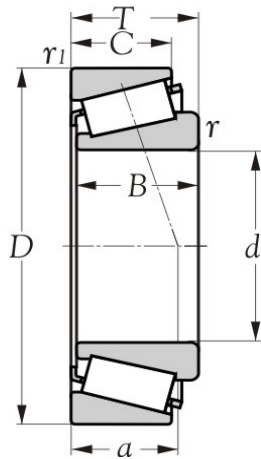

Items (18)	Data  Model nos.	Dimension			Packing method	Quantity  Min. order qty.	Delivery  Days	-	2014-09-01	Compare percentages (%)	Production code(s)		
		Bearing sizes										Unit price structure	Unit price structure
		d	D	T									
		mm				Pcs							
1	30203-A	17	40	13.25	N1	275	105	-	1.75	-	THLS		
2	30204-A	20	47	15.25	N1	225	105	-	2.20	-	THLS		
3	* 30205-A	25	52	16.25	N1	200	105	-	2.53	-	THLS		
4	30206-A	30	62	17.25	N1	175	105	-	2.79	-	THLS		
5	* 30207-A	35	72	18.25	N1	150	105	-	3.11	-	THLS		
6	30208-A	40	80	19.75	N1	100	105	-	4.59	-	THLS		
7	* 30209-A	45	85	20.75	N1	100	105	-	4.89	-	THLS		
8	* 30210-A	50	90	21.75	N1	100	105	-	5.56	-	THLS		
9	* 30211-A	55	100	22.75	N1	75	105	-	7.24	-	THLS		
10	* 30212-A	60	110	23.75	N1	75	105	-	8.24	-	THLS		
11	30213-A	65	120	24.75	N1	50	105	-	9.54	-	THLS		
12	* 30214-A	70	125	26.25	N1	45	105	-	10.88	-	THLS		
13	* 30215-A	75	130	27.25	N1	40	105	-	11.53	-	THLS		
14	30216-A	80	140	28.25	N1	35	105	-	13.49	-	THLS		
15	30217-A	85	150	30.5	N1	30	105	-	17.13	-	THLS		
16	30218-A	90	160	32.5	N1	25	105	-	20.96	-	THLS		
17	30219-A	95	170	34.5	N1	20	105	-	24.34	-	THLS		
18	30220-A	100	180	37	N1	20	105	-	29.78	-	THLS		

<b>Remark</b>	Technical supplement	Precision	Grease
	Cage(s)		
	Steel - ✓	Class 0 (JIS)	Nil
	Polymid - ✗		
Brass - ✗			

Qualified Sub-contractor(s)	Since
THLS	2005
-	-
-	-

**TAPER ROLLER BEARING**  
**SERIES 303**

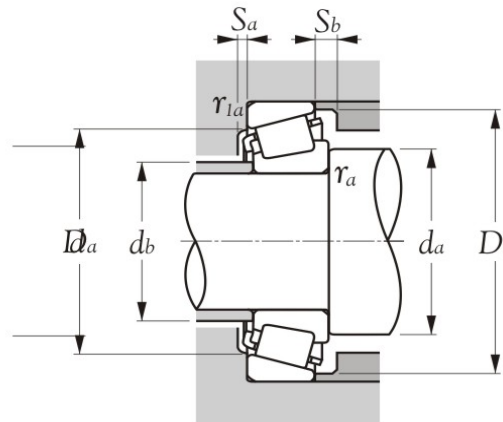
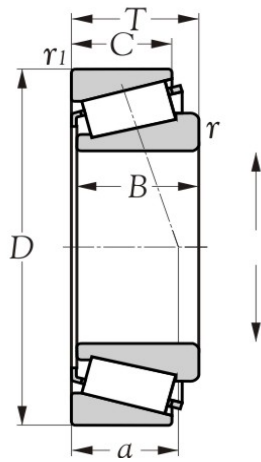

Items (14)	Data  Model nos.	Dimension			Packing method	Quantity  Min. order qty.	Delivery  Days	Unit price structure  USD	2014-09-01  Unit price structure  USD	Compare percentages (%)	Production code(s)
		Bearing sizes									
		d	D	T							
		mm				Pcs					
1	30303	17	47	15.25	N1	225	105	-	2.10	-	THLS
2	30304	20	52	16.25	N1	200	105	-	2.44	-	THLS
3	30305	25	62	18.25	N1	150	105	-	3.09	-	THLS
4	30306	30	72	20.75	N1	125	105	-	3.91	-	THLS
5	* 30307	35	80	22.75	N1	100	105	-	4.89	-	THLS
6	30308	40	90	25.25	N1	75	105	-	6.25	-	THLS
7	30309	45	100	27.25	N1	75	105	-	8.24	-	THLS
8	30310	50	110	29.25	N1	45	105	-	10.21	-	THLS
9	30311	55	120	31.5	N1	40	105	-	12.20	-	THLS
10	30312	60	130	33.5	N1	30	105	-	14.94	-	THLS
11	30313	65	140	36	N1	30	105	-	17.61	-	THLS
12	30314	70	150	38	N1	25	105	-	21.60	-	THLS
13	30315	75	160	40	N1	20	105	-	25.59	-	THLS
14	30316	80	170	42.5	N1	15	105	-	30.90	-	THLS

<b>Remark</b>	Technical supplement		
	Cage(s)	Precision	Grease
	Steel - ✓	Class 0 (JIS)	Nil
	Polymid - ✗		
Brass - ✗			

Qualified Sub-contractor(s)	Since
THLS	2005
-	-
-	-

**TAPER ROLLER BEARING**  
**SERIES 320**

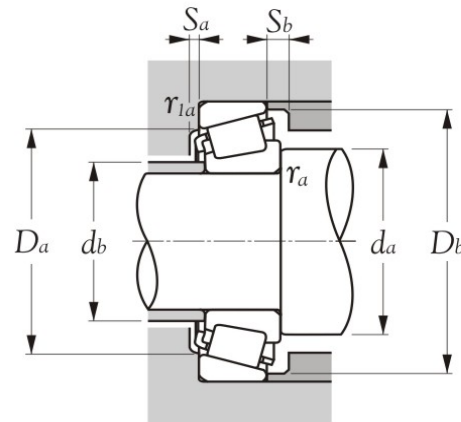
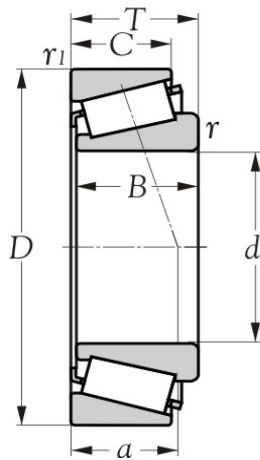

Items (20)	Data  Model nos.	Dimension			Packing method	Quantity  Min. order qty.	Delivery  Days	-	2014-09-01	Compare percentages (%)	Production code(s)		
		Bearing sizes										Unit price structure	Unit price structure
		d	D	T									
		mm				Pcs							
1	32004 X	20	42	15	N1	175	105	-	2.74	-	THLS		
2	320/22 X	22	44	15	N1	75	105	-	6.46	-	THLS		
3	32005 X	25	47	15	N1	175	105	-	2.85	-	THLS		
4	320/28 X	28	52	16	N1	75	105	-	6.46	-	THLS		
5	* 32006 X	30	55	17	N1	175	105	-	2.91	-	THLS		
6	320/32 X	32	58	17	N1	75	105	-	6.46	-	THLS		
7	* 32007 X	35	62	18	N1	150	105	-	3.56	-	THLS		
8	* 32008 X	40	68	19	N1	125	105	-	4.06	-	THLS		
9	32009 X	45	75	20	N1	100	105	-	4.85	-	THLS		
10	* 32010 X	50	80	20	N1	100	105	-	5.49	-	THLS		
11	* 32011 X	55	90	23	N1	75	105	-	6.51	-	THLS		
12	* 32012 X	60	95	23	N1	75	105	-	6.84	-	THLS		
13	32013 X	65	100	23	N1	75	105	-	7.19	-	THLS		
14	32014 X	70	110	25	N1	75	105	-	8.49	-	THLS		
15	* 32015 X	75	115	25	N1	50	105	-	9.78	-	THLS		
16	* 32016 X	80	125	29	N1	40	105	-	11.76	-	THLS		
17	32017 X	85	130	29	N1	35	105	-	12.74	-	THLS		
18	* 32018 X	90	140	32	N1	30	105	-	15.24	-	THLS		
19	32019 X	95	145	32	N1	30	105	-	15.56	-	THLS		
20	32020 X	100	150	32	N1	30	105	-	16.93	-	THLS		

<b>Remark</b>	Technical supplement	Precision	Grease
	Cage(s)		
	Steel - <input checked="" type="checkbox"/>	Class 0 (JIS)	Nil
	Polymid - <input checked="" type="checkbox"/>		
Brass - <input checked="" type="checkbox"/>			

Qualified Sub-contractor(s)	Since
THLS	2005
-	-
-	-

**TAPER ROLLER BEARING**  
**SERIES 320**

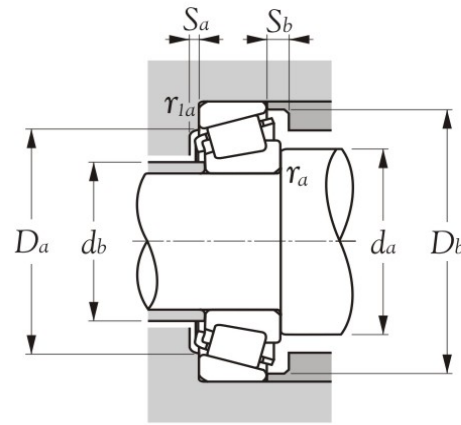
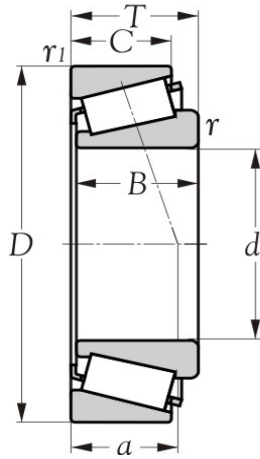

Items (3)	Data	Dimension			Packing method	Quantity Min. order qty.	Delivery	-	2014-09-01	Compare percentages (%)	Production code(s)		
	Model nos.	Bearing sizes										Unit price structure	Unit price structure
		d	D	T									
		mm				Pcs	Days						
21	<b>32021 X</b>	105	160	35	N1	20	105	-	<b>23.48</b>	-	THLS		
22	<b>32022 X</b>	110	170	38	N1	20	105	-	<b>28.50</b>	-	THLS		
23	<b>32024 X</b>	120	180	38	N1	15	105	-	<b>32.86</b>	-	THLS		

Remark	Technical supplement								
	Cage(s)	Precision	Grease						
	<table border="1"> <tr> <td>Steel -</td> <td>✓</td> </tr> <tr> <td>Polymid -</td> <td>×</td> </tr> <tr> <td>Brass -</td> <td>×</td> </tr> </table>	Steel -	✓	Polymid -	×	Brass -	×	Class 0 (JIS)	Nil
Steel -	✓								
Polymid -	×								
Brass -	×								

Qualified Sub-contractor(s)	Since
THLS	2005
-	-
-	-



**TAPER ROLLER BEARING**  
**SERIES 322**

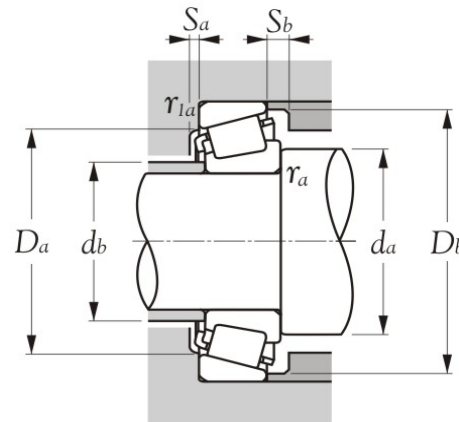
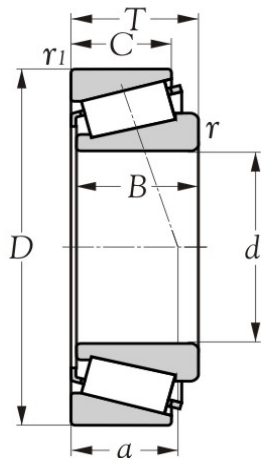

Items (13)	Data  Model nos.	Dimension			Packing method	Quantity  Min. order qty.	Delivery  Days	-	2014-09-01	Compare percentages (%)	Production code(s)		
		Bearing sizes										Unit price structure	Unit price structure
		d	D	T									
		mm				Pcs							
1	32205-A	25	52	19.25	N1	175	105	-	2.91	-	THLS		
2	32206-A	30	62	21.25	N1	150	105	-	3.43	-	THLS		
3	* 32207-A	35	72	24.25	N1	125	105	-	4.25	-	THLS		
4	* 32208-A	40	80	24.75	N1	100	105	-	5.21	-	THLS		
5	* 32209-A	45	85	24.75	N1	100	105	-	5.56	-	THLS		
6	32210-A	50	90	24.75	N1	75	105	-	6.21	-	THLS		
7	32211-A	55	100	26.75	N1	75	105	-	7.85	-	THLS		
8	32212-A	60	110	29.75	N1	50	105	-	9.21	-	THLS		
9	32213-A	65	120	32.75	N1	40	105	-	11.85	-	THLS		
10	* 32214-A	70	125	33.25	N1	35	105	-	12.85	-	THLS		
11	32215-A	75	130	33.25	N1	35	105	-	14.16	-	THLS		
12	32216-A	80	140	35.25	N1	30	105	-	17.13	-	THLS		
13	32217-A	85	150	38.5	N1	25	105	-	20.41	-	THLS		

<b>Remark</b>	Technical supplement		
	Cage(s)	Precision	Grease
	Steel - ✓	Class 0 (JIS)	Nil
	Polymid - ✗		
Brass - ✗			

Qualified Sub-contractor(s)	Since
THLS	2005
-	-
-	-

**TAPER ROLLER BEARING**  
**SERIES 323**

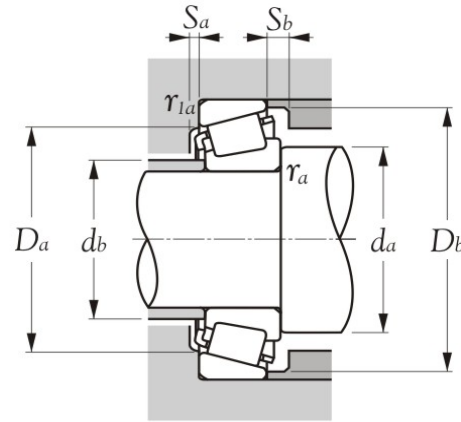
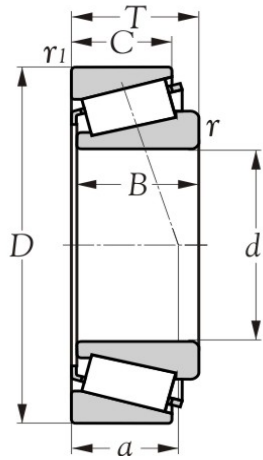

Items (9)	Data Model nos.	Dimension			Packing method	Quantity Min. order qty.	Delivery Days	Unit price structure USD	2014-09-01 Unit price structure USD	Compare percentages (%)	Production code(s)
		Bearing sizes									
		d	D	T							
		mm				Pcs					
1	32304-A	20	52	22.25	N1	200	105	-	2.35	-	THLS
2	32305-A	25	62	25.25	N1	125	105	-	3.93	-	THLS
3	* 32306-A	30	72	28.75	N1	100	105	-	5.21	-	THLS
4	* 32307-A	35	80	32.75	N1	75	105	-	6.59	-	THLS
5	32308-A	40	90	35.25	N1	75	105	-	8.24	-	THLS
6	32309-A	45	100	38.25	N1	45	105	-	10.88	-	THLS
7	* 32310-A	50	110	42.25	N1	35	105	-	13.95	-	THLS
8	* 32311-A	55	120	45.5	N1	30	105	-	16.28	-	THLS
9	* 32312-A	60	130	48.5	N1	25	105	-	19.93	-	THLS

<b>Remark</b>	Technical supplement	Precision	Grease
	Cage(s)		
	Steel - ✓	Class 0 (JIS)	Nil
	Polymid - ✗		
Brass - ✗			

Qualified Sub-contractor(s)	Since
THLS	2005
-	-
-	-

**TAPER ROLLER BEARING**  
**SERIES 332**

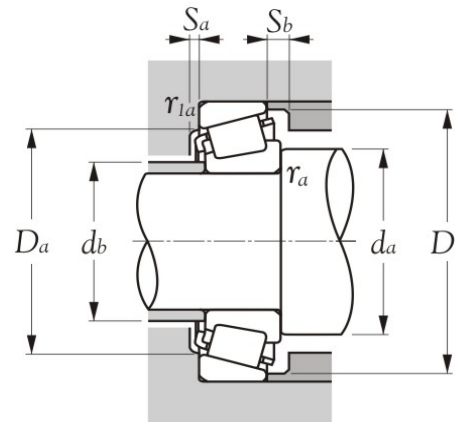
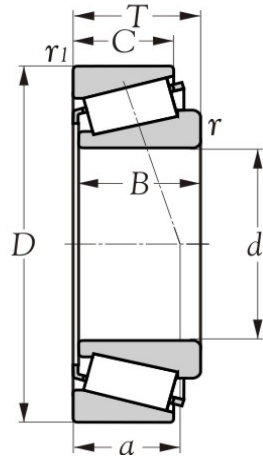

Items (7)	Data  Model nos.	Dimension			Packing method	Quantity  Min. order qty.	Delivery  Days	-	2014-09-01	Compare percentages (%)	Production code(s)		
		Bearing sizes										Unit price structure	Unit price structure
		d	D	T									
		mm				Pcs		USD	USD				
1	33205	25	52	22	N1	100	105	-	4.85	-	THLS		
2	33206	30	62	25	N1	100	105	-	5.83	-	THLS		
3	33207	35	72	28	N1	75	105	-	6.46	-	THLS		
4	33208	40	80	32	N1	75	105	-	7.51	-	THLS		
5	33209	45	85	32	N1	75	105	-	8.15	-	THLS		
6	33210	50	90	32	N1	75	105	-	8.49	-	THLS		
7	33211	55	100	35	N1	40	105	-	11.41	-	THLS		

<b>Remark</b>	Technical supplement		
	Cage(s)	Precision	Grease
	Steel - ✓	Class 0 (JIS)	Nil
	Polymid - ✗		
Brass - ✗			

Qualified Sub-contractor(s)	Since
THLS	2005
-	-
-	-



# SPHERICAL ROLLER BEARINGS



**SPHERICAL ROLLER BEARINGS**

**SERIES 213**

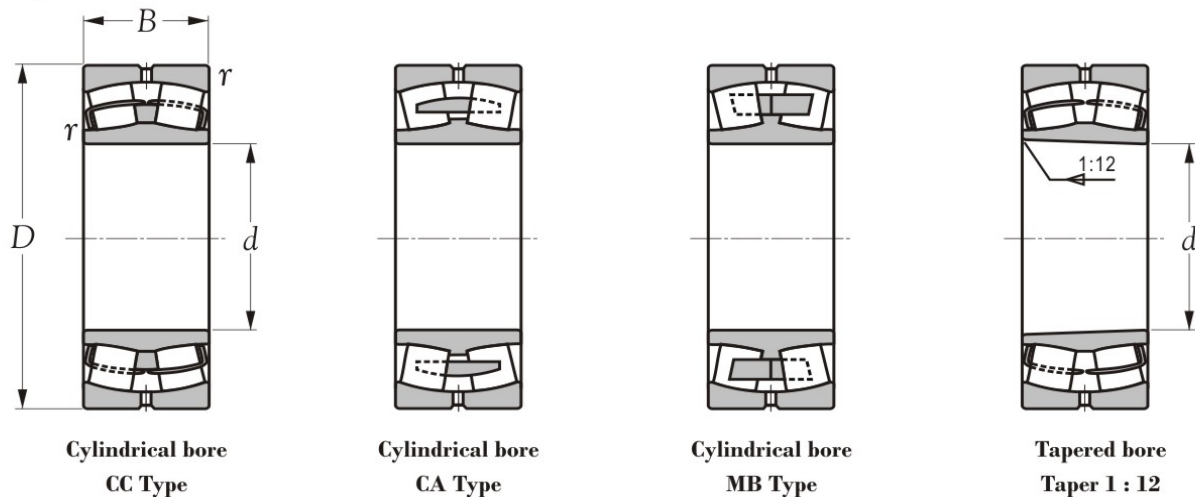

Items (20)	Data  Model nos.	Dimension			Packing method	Quantity  Min. order qty.  Pcs	Delivery  Days	-	2014-09-01	-	Production code(s)			
		Bearing sizes										Unit price structure  USD	Unit price structure  USD	Compare percentages (%)
		d	D	B										
		mm												
1	21304 MB W33	20	52	15	N1	130	105	-	14.54	-	XSYC			
2	21304 MB/K W33	20	52	15	N1	130	105	-	15.28	-	XSYC			
3	21304 CA W33	20	52	15	N1	130	105	-	14.54	-	XSYC			
4	21304 CA/K W33	20	52	15	N1	130	105	-	15.28	-	XSYC			
5	21305 MB W33	25	62	17	N1	88	105	-	17.94	-	XSYC			
6	21305 MB/K W33	25	62	17	N1	88	105	-	17.94	-	XSYC			
7	21305 CA W33	25	62	17	N1	88	105	-	17.94	-	XSYC			
8	21305 CA/K W33	25	62	17	N1	88	105	-	17.94	-	XSYC			
9	21306 MB W33	30	72	19	N1	83	105	-	18.61	-	XSYC			
10	21306 MB/K W33	30	72	19	N1	83	105	-	18.61	-	XSYC			
11	21306 CA W33	30	72	19	N1	83	105	-	18.61	-	XSYC			
12	21306 CA/K W33	30	72	19	N1	83	105	-	18.61	-	XSYC			
13	21306 CC W33	30	72	19	N1	83	105	-	17.61	-	XSYC			
14	21306 CC/K W33	30	72	19	N1	83	105	-	17.61	-	XSYC			
15	21307 MB W33	35	80	21	N1	78	105	-	16.25	-	XSYC			
16	21307 MB/K W33	35	80	21	N1	78	105	-	16.91	-	XSYC			
17	21307 CA W33	35	80	21	N1	78	105	-	16.25	-	XSYC			
18	21307 CA/K W33	35	80	21	N1	78	105	-	16.91	-	XSYC			
19	21307 CC W33	35	80	21	N1	78	105	-	16.91	-	XSYC			
20	21307 CC/K W33	35	80	21	N1	78	105	-	16.91	-	XSYC			

Remark	Technical supplement		
	Cage(s)	Precision	Grease
	Steel - CC Polymid - X Brass - CA, MB	Class 0 (JIS)	Nil

Qualified Sub-contractor(s)	Since
XSYC	2013
-	-
-	-

SPHERICAL ROLLER BEARINGS

SERIES **213**

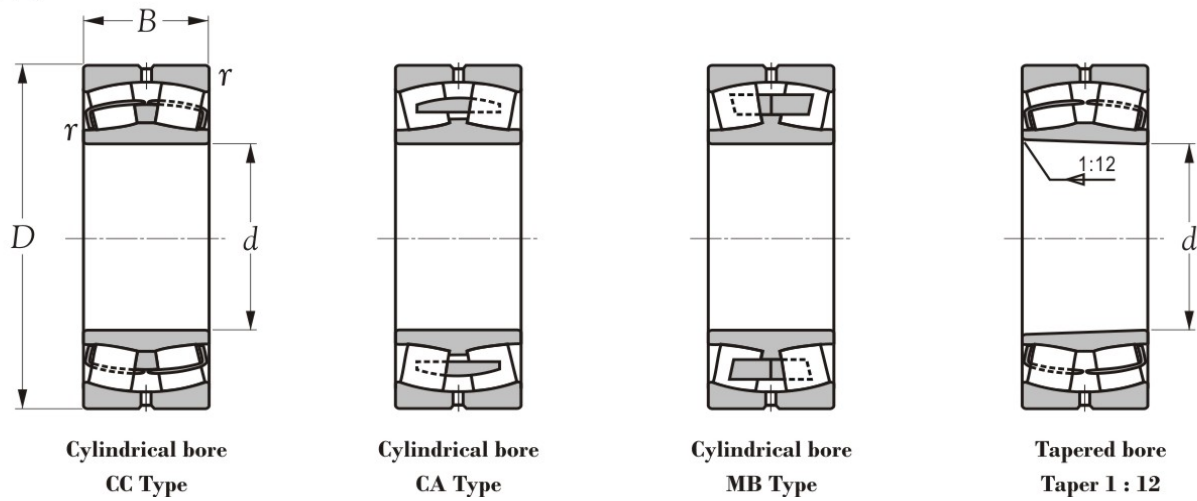

Items (20)	Data  Model nos.	Dimension			Packing method	Quantity  Min. order qty.  Pcs	Delivery  Days	-	Unit price structure  USD	2014-09-01	Compare percentages (%)	Production code(s)
		Bearing sizes								Unit price structure		
		d	D	B						USD		
		mm							USD			
21	21308 MB W33	40	90	23	N1	73	105	-	19.04	-	XSYC	
22	21308 MB/K W33	40	90	23	N1	73	105	-	19.04	-	XSYC	
23	21308 CA W33	40	90	23	N1	73	105	-	19.04	-	XSYC	
24	21308 CA/K W33	40	90	23	N1	73	105	-	19.04	-	XSYC	
25	21308 CC W33	40	90	23	N1	73	105	-	19.04	-	XSYC	
26	21308 CC/K W33	40	90	23	N1	73	105	-	19.04	-	XSYC	
27	21309 MB W33	45	100	25	N1	73	105	-	20.31	-	XSYC	
28	21309 MB/K W33	45	100	25	N1	73	105	-	20.31	-	XSYC	
29	21309 CA W33	45	100	25	N1	73	105	-	20.31	-	XSYC	
30	21309 CA/K W33	45	100	25	N1	73	105	-	20.31	-	XSYC	
31	21309 CC W33	45	100	25	N1	73	105	-	19.64	-	XSYC	
32	21309 CC/K W33	45	100	25	N1	73	105	-	19.64	-	XSYC	
33	21310 MB W33	50	110	27	N1	68	105	-	22.01	-	XSYC	
34	21310 MB/K W33	55	120	29	N1	68	105	-	22.01	-	XSYC	
35	21310 CA W33	50	110	27	N1	68	105	-	22.01	-	XSYC	
36	21310 CA/K W33	55	120	29	N1	68	105	-	22.01	-	XSYC	
37	21310 CC W33	35	80	21	N1	68	105	-	21.33	-	XSYC	
38	21310 CC/K W33	35	80	21	N1	68	105	-	21.33	-	XSYC	
39	21311 MB W33	55	120	29	N1	63	105	-	25.39	-	XSYC	
40	21311 MB/K W33	55	120	29	N1	63	105	-	25.39	-	XSYC	

<b>Remark</b>	Technical supplement	Precision	Grease
	Cage(s)		
	Steel - CC	Class 0 (JIS)	Nil
	Polymid - X		
Brass - CA, MB			

Qualified Sub-contractor(s)	Since
XSYC	2013
-	-
-	-

**SPHERICAL ROLLER BEARINGS**

**SERIES 213**

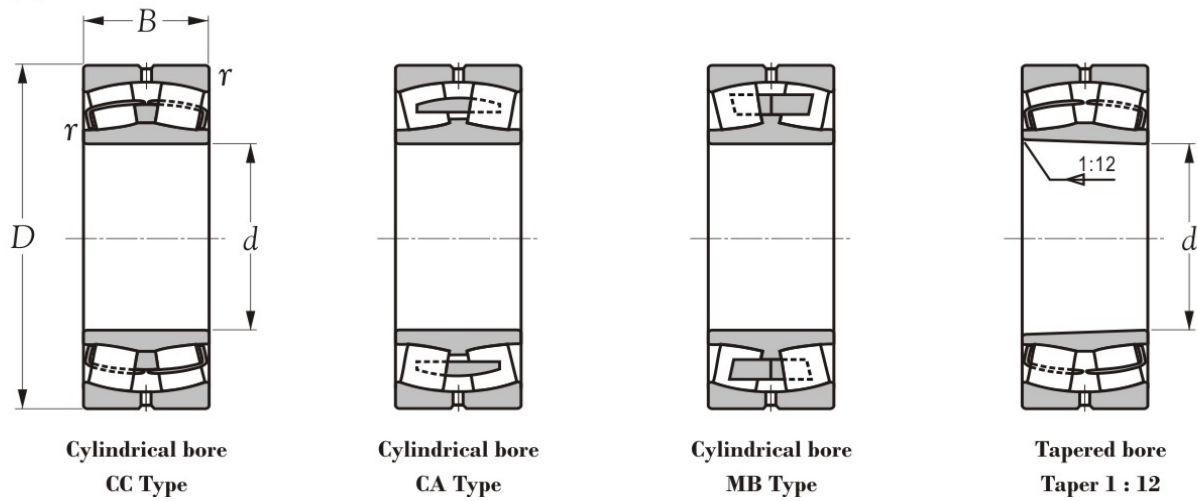

Items (20)	Data  Model nos.	Dimension			Packing method	Quantity  Min. order qty.  Pcs	Delivery  Days	-	2014-09-01	-	Production code(s)			
		Bearing sizes										Unit price structure  USD	Unit price structure  USD	Compare percentages (%)
		d	D	B										
		mm												
41	21311 CA W33	55	120	29	N1	63	105	-	25.39	-	XSYC			
42	21311 CA/K W33	55	120	29	N1	63	105	-	25.39	-	XSYC			
43	21311 CC W33	40	90	23	N1	63	105	-	24.71	-	XSYC			
44	21311 CC/K W33	40	90	23	N1	63	105	-	24.71	-	XSYC			
45	21312 MB W33	60	130	31	N1	58	105	-	28.78	-	XSYC			
46	21312 MB/K W33	60	130	31	N1	58	105	-	28.78	-	XSYC			
47	21312 CA W33	60	130	31	N1	58	105	-	28.78	-	XSYC			
48	21312 CA/K W33	60	130	31	N1	58	105	-	28.78	-	XSYC			
49	21312 CC W33	45	100	25	N1	58	105	-	28.09	-	XSYC			
50	21312 CC/K W33	45	100	25	N1	58	105	-	28.09	-	XSYC			
51	21313 MB W33	65	140	33	N1	53	105	-	32.15	-	XSYC			
52	21313 MB/K W33	65	140	33	N1	53	105	-	32.15	-	XSYC			
53	21313 CA W33	65	140	33	N1	53	105	-	32.15	-	XSYC			
54	21313 CA/K W33	65	140	33	N1	53	105	-	32.15	-	XSYC			
55	21313 CC W33	50	110	27	N1	53	105	-	31.49	-	XSYC			
56	21313 CC/K W33	55	120	29	N1	53	105	-	31.49	-	XSYC			
57	21314 MB W33	70	150	35	N1	45	105	-	35.54	-	XSYC			
58	21314 MB/K W33	70	150	35	N1	45	105	-	35.54	-	XSYC			
59	21314 CA W33	70	150	35	N1	45	105	-	35.54	-	XSYC			
60	21314 CA/K W33	70	150	35	N1	45	105	-	35.54	-	XSYC			

<b>Remark</b>	Technical supplement		
	Cage(s)	Precision	Grease
	Steel - CC	Class 0 (JIS)	Nil
	Polymid - X		
Brass - CA, MB			

Qualified Sub-contractor(s)	Since
XSYC	2013
-	-
-	-



**SPHERICAL ROLLER BEARINGS**

**SERIES 213**

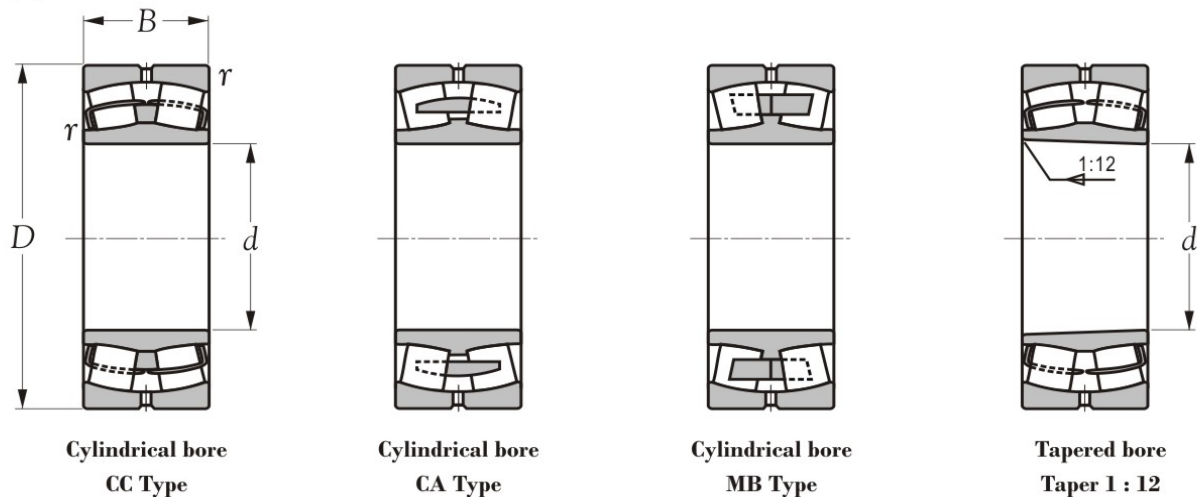

Items (20)	Data  Model nos.	Dimension			Packing method	Quantity  Min. order qty.  Pcs	Delivery  Days	-	2014-09-01	Compare	Production				
		Bearing sizes										Unit price structure  USD	Unit price structure  USD	percentages (%)	code(s)
		d	D	B											
		mm													
61	21314 CC W33	55	120	29	N1	45	105	-	34.86	-	XSYC				
62	21314 CC/K W33	55	120	29	N1	45	105	-	34.86	-	XSYC				
63	21315 MB W33	75	160	37	N1	40	105	-	45.70	-	XSYC				
64	21315 MB/K W33	75	160	37	N1	40	105	-	45.70	-	XSYC				
65	21315 CA W33	75	160	37	N1	40	105	-	45.70	-	XSYC				
66	21315 CA/K W33	75	160	37	N1	40	105	-	45.70	-	XSYC				
67	21315 CC W33	60	130	31	N1	40	105	-	44.68	-	XSYC				
68	21315 CC/K W33	60	130	31	N1	40	105	-	44.68	-	XSYC				
69	21316 MB W33	80	170	39	N1	35	105	-	52.46	-	XSYC				
70	21316 MB/K W33	80	170	39	N1	35	105	-	52.46	-	XSYC				
71	21316 CA W33	80	170	39	N1	35	105	-	52.46	-	XSYC				
72	21316 CA/K W33	80	170	39	N1	35	105	-	52.46	-	XSYC				
73	21316 CC W33	65	140	33	N1	35	105	-	50.78	-	XSYC				
74	21316 CC/K W33	65	140	33	N1	35	105	-	50.78	-	XSYC				
75	21317 MB W33	85	180	41	N1	30	105	-	64.31	-	XSYC				
76	21317 MB/K W33	85	180	41	N1	30	105	-	64.31	-	XSYC				
77	21317 CA W33	85	180	41	N1	30	105	-	64.31	-	XSYC				
78	21317 CA/K W33	85	180	41	N1	30	105	-	64.31	-	XSYC				
79	21317 CC W33	85	180	41	N1	30	105	-	62.61	-	XSYC				
80	21317 CC/K W33	85	180	41	N1	30	105	-	62.61	-	XSYC				

<b>Remark</b>	Technical supplement		
	Cage(s)	Precision	Grease
	Steel - CC	Class 0 (JIS)	Nil
	Polymid - X		
Brass - CA, MB			

Qualified Sub-contractor(s)	Since
XSYC	2013
-	-
-	-



SPHERICAL ROLLER BEARINGS

SERIES **213**

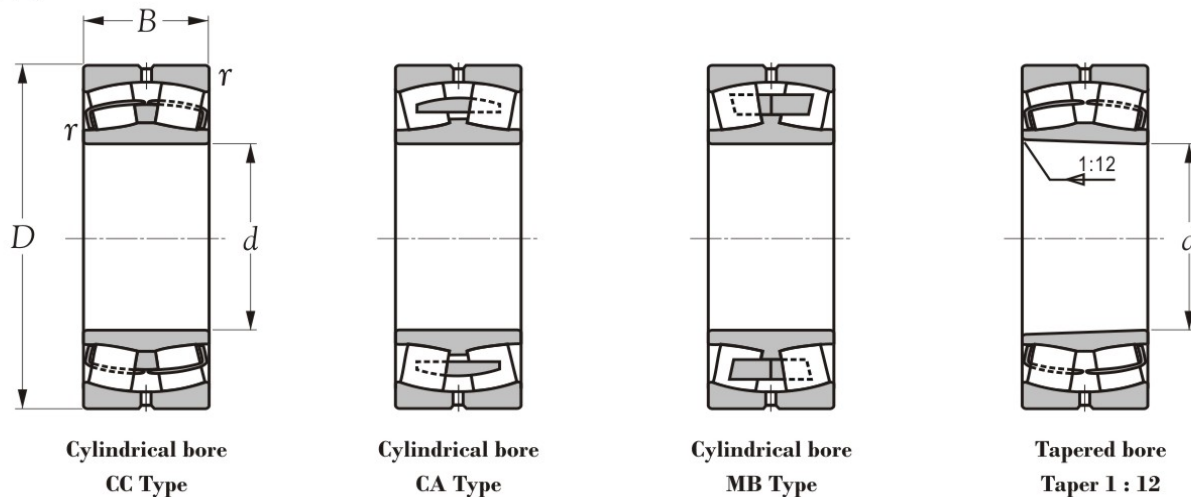

Items (20)	Data  Model nos.	Dimension			Packing method	Quantity  Min. order qty.  Pcs	Delivery  Days	-	2014-09-01	Compare	Production				
		Bearing sizes										Unit price structure  USD	Unit price structure  USD	percentages (%)	code(s)
		d	D	B											
		mm													
81	21318 MB W33	90	190	43	N1	25	105	-	67.69	-	XSYC				
82	21318 MB/K W33	90	190	43	N1	25	105	-	67.69	-	XSYC				
83	21318 CA W33	90	190	43	N1	25	105	-	67.69	-	XSYC				
84	21318 CA/K W33	90	190	43	N1	25	105	-	67.69	-	XSYC				
85	21318 CC W33	90	190	43	N1	25	105	-	66.01	-	XSYC				
86	21318 CC/K W33	90	190	43	N1	25	105	-	66.01	-	XSYC				
87	21319 MB W33	95	200	45	N1	25	105	-	74.46	-	XSYC				
88	21319 MB/K W33	95	200	45	N1	25	105	-	74.46	-	XSYC				
89	21319 CA W33	95	200	45	N1	25	105	-	74.46	-	XSYC				
90	21319 CA/K W33	95	200	45	N1	25	105	-	74.46	-	XSYC				
91	21319 CC W33	95	200	45	N1	25	105	-	72.78	-	XSYC				
92	21319 CC/K W33	95	200	45	N1	25	105	-	72.78	-	XSYC				
93	21320 MB W33	100	215	47	N1	20	105	-	94.78	-	XSYC				
94	21320 MB/K W33	100	215	47	N1	20	105	-	94.78	-	XSYC				
95	21320 CA W33	100	215	47	N1	20	105	-	94.78	-	XSYC				
96	21320 CA/K W33	100	215	47	N1	20	105	-	94.78	-	XSYC				
97	21320 CC W33	100	215	47	N1	20	105	-	91.39	-	XSYC				
98	21320 CC/K W33	100	215	47	N1	20	105	-	93.09	-	XSYC				
99	21322 MB W33	110	240	50	N1	15	105	-	118.48	-	XSYC				
100	21322 MB/K W33	110	240	50	N1	15	105	-	118.48	-	XSYC				

<b>Remark</b>	Technical supplement	Precision	Grease
	Cage(s)		
	Steel - CC	Class 0 (JIS)	Nil
	Polymid - X		
Brass - CA, MB			

Qualified Sub-contractor(s)	Since
XSYC	2013
-	-
-	-

**SPHERICAL ROLLER BEARINGS**  
**SERIES 213**

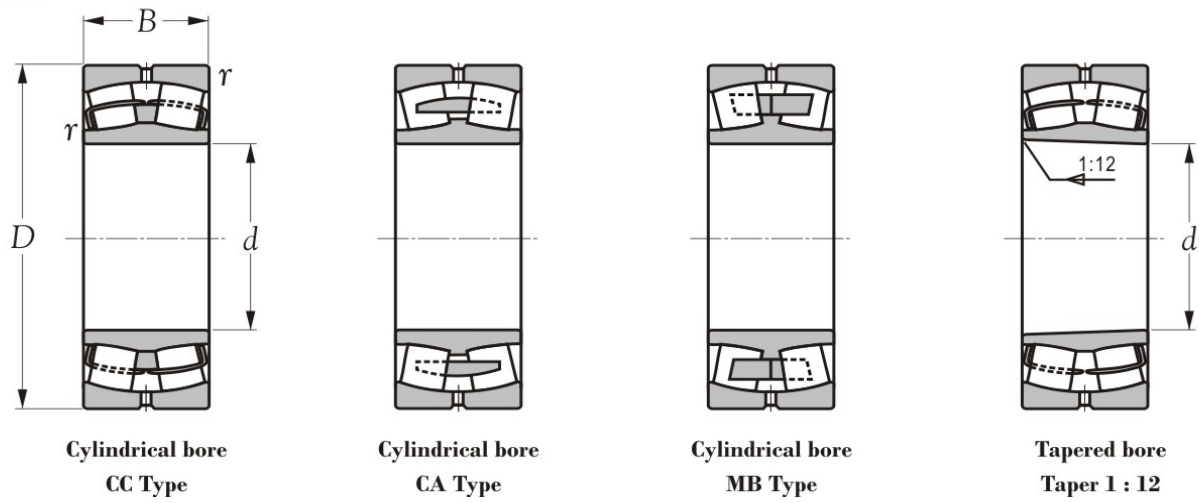

Items (4)	Data  Model nos.	Dimension			Packing method	Quantity  Min. order qty.  Pcs	Delivery  Days	-	Unit price structure  USD	2014-09-01	Compare percentages (%)	Production code(s)
		Bearing sizes								Unit price		
		d	D	B						structure		
		mm							USD			
101	21322 CA W33	110	240	50	N1	15	105	-	118.48	-	XSYC	
102	21322 CA/K W33	110	240	50	N1	15	105	-	118.48	-	XSYC	
103	21322 CC W33	110	240	50	N1	15	105	-	118.48	-	XSYC	
104	21322 CC/K W33	110	240	50	N1	15	105	-	118.48	-	XSYC	

<b>Remark</b>	Technical supplement	Precision	Grease
	Cage(s)		
	Steel - CC	Class 0 (JIS)	Nil
	Polymid - X		
Brass - CA, MB			

Qualified Sub-contractor(s)	Since
XSYC	2013
-	-
-	-

**SPHERICAL ROLLER BEARINGS**

**SERIES 222**

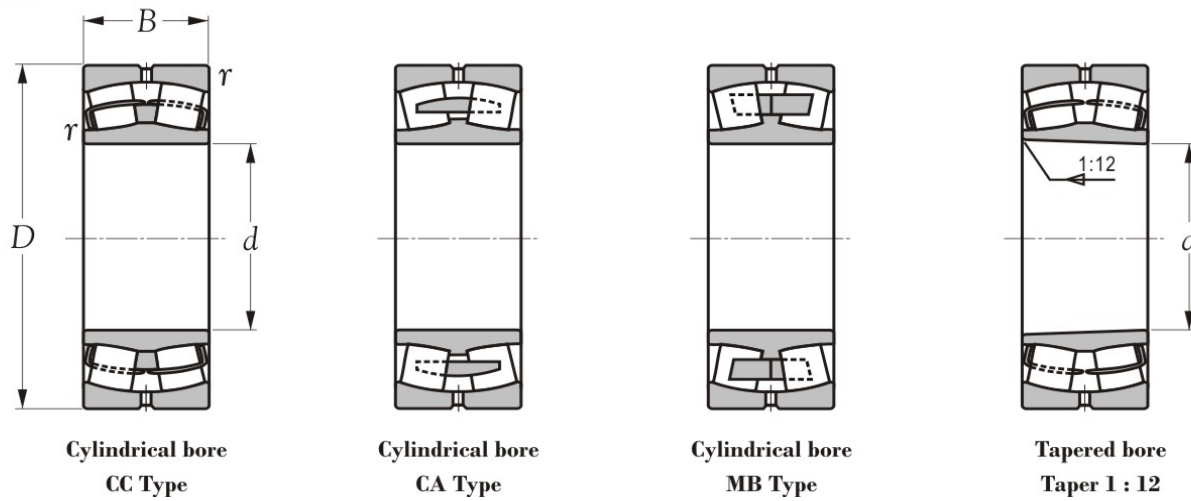

Items (20)	Data Model nos.	Dimension			Packing method	Quantity Min. order qty. Pcs	Delivery Days	Unit price structure USD	2014-09-01 Unit price structure USD	Compare percentages (%)	Production code(s)
		Bearing sizes									
		d	D	B							
1	22205 MB W33	25	52	18	N1	130	105	-	12.88	-	XSYC
2	22205 MB/K W33	25	52	18	N1	130	105	-	12.88	-	XSYC
3	22205 CA W33	25	52	18	N1	130	105	-	12.88	-	XSYC
4	22205 CA/K W33	25	52	18	N1	130	105	-	12.88	-	XSYC
5	22205 CC W33	25	52	18	N1	130	105	-	12.51	-	XSYC
6	22205 CC/K W33	25	52	18	N1	130	105	-	12.51	-	XSYC
7	22206 MB W33	30	62	20	N1	125	105	-	12.88	-	XSYC
8	22206 MB/K W33	30	62	20	N1	125	105	-	12.88	-	XSYC
9	22206 CA W33	30	62	20	N1	125	105	-	12.88	-	XSYC
10	22206 CA/K W33	30	62	20	N1	125	105	-	12.88	-	XSYC
11	22206 CC W33	30	62	20	N1	125	105	-	12.51	-	XSYC
12	22206 CC/K W33	30	62	20	N1	125	105	-	12.51	-	XSYC
13	22207 MB W33	35	72	23	N1	118	105	-	13.54	-	XSYC
14	22207 MB/K W33	35	72	23	N1	118	105	-	13.54	-	XSYC
15	22207 CA W33	35	72	23	N1	118	105	-	13.54	-	XSYC
16	22207 CA/K W33	35	72	23	N1	118	105	-	13.54	-	XSYC
17	22207 CC W33	35	72	23	N1	118	105	-	13.20	-	XSYC
18	22207 CC/K W33	35	72	23	N1	118	105	-	13.20	-	XSYC
19	22208 MB W33	40	80	23	N1	113	105	-	14.21	-	XSYC
20	22208 MB/K W33	40	80	23	N1	113	105	-	14.21	-	XSYC

<b>Remark</b>	Technical supplement		
	Cage(s)	Precision	Grease
	Steel - CC	Class 0 (JIS)	Nil
	Polymid - X		
Brass - CA, MB			

Qualified Sub-contractor(s)	Since
XSYC	2013
-	-
-	-

**SPHERICAL ROLLER BEARINGS**

**SERIES 222**

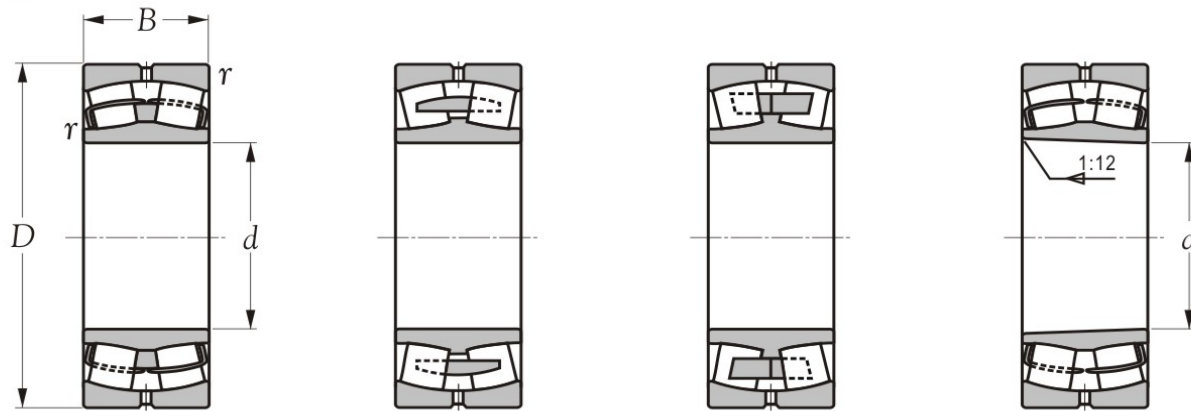

Cylindrical bore  
CC Type

Cylindrical bore  
CA Type

Cylindrical bore  
MB Type

Tapered bore  
Taper 1 : 12

Items (20)	Data  Model nos.	Dimension			Packing method	Quantity  Min. order qty.  Pcs	Delivery  Days	-	Unit price structure  USD	2014-09-01	Compare percentages (%)	Production code(s)
		Bearing sizes								Unit price structure		
		d	D	B						USD		
		mm							USD			
21	22208 CA W33	40	80	23	N1	113	105	-	14.21	-	XSYC	
22	22208 CA/K W33	40	80	23	N1	113	105	-	14.21	-	XSYC	
23	22208 CC W33	40	80	23	N1	113	105	-	13.88	-	XSYC	
24	22208 CC/K W33	40	80	23	N1	113	105	-	13.88	-	XSYC	
25	22209 MB W33	45	85	23	N1	108	105	-	14.89	-	XSYC	
26	22209 MB/K W33	45	85	23	N1	108	105	-	14.89	-	XSYC	
27	22209 CA W33	45	85	23	N1	108	105	-	14.89	-	XSYC	
28	22209 CA/K W33	45	85	23	N1	108	105	-	14.89	-	XSYC	
29	22209 CC W33	45	85	23	N1	108	105	-	14.55	-	XSYC	
30	22209 CC/K W33	45	85	23	N1	108	105	-	14.55	-	XSYC	
31	* 22210 MB W33	50	90	23	N1	103	105	-	15.58	-	XSYC	
32	22210 MB/K W33	50	90	23	N1	103	105	-	15.58	-	XSYC	
33	22210 CA W33	50	90	23	N1	103	105	-	15.58	-	XSYC	
34	22210 CA/K W33	50	90	23	N1	103	105	-	15.58	-	XSYC	
35	22210 CC W33	50	90	23	N1	103	105	-	15.24	-	XSYC	
36	22210 CC/K W33	50	90	23	N1	103	105	-	15.24	-	XSYC	
37	22211 MB W33	55	100	25	N1	95	105	-	17.61	-	XSYC	
38	22211 MB/K W33	55	100	25	N1	95	105	-	17.61	-	XSYC	
39	22211 CA W33	55	100	25	N1	95	105	-	17.61	-	XSYC	
40	22211 CA/K W33	55	100	25	N1	95	105	-	17.61	-	XSYC	

<b>Remark</b>	Technical supplement	Precision	Grease
	Cage(s)		
	Steel - CC	Class 0 (JIS)	Nil
	Polymid - X		
Brass - CA, MB			

Qualified Sub-contractor(s)	Since
XSYC	2013
-	-
-	-

**SPHERICAL ROLLER BEARINGS**

**SERIES 222**

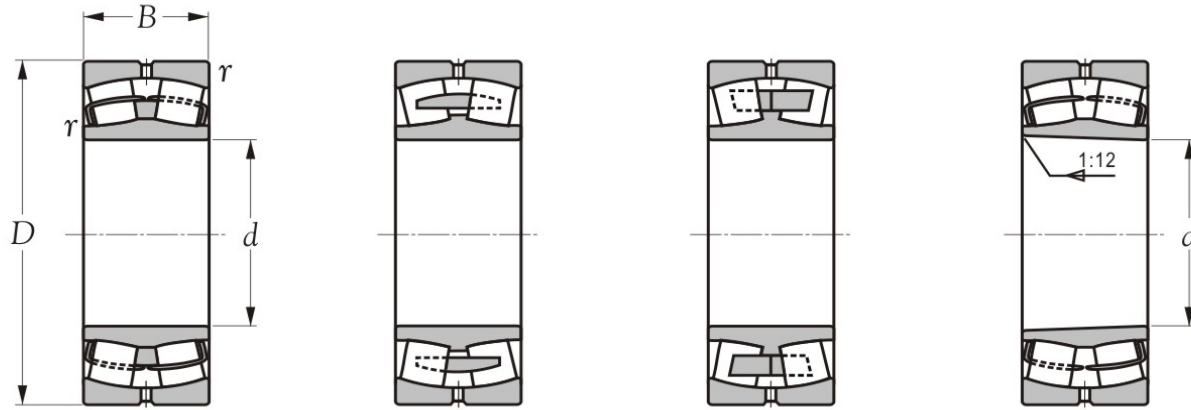

Cylindrical bore  
CC Type

Cylindrical bore  
CA Type

Cylindrical bore  
MB Type

Tapered bore  
Taper 1 : 12

Items (20)	Data  Model nos.	Dimension			Packing method	Quantity  Min. order qty.  Pcs	Delivery  Days	-	Unit price structure  USD	2014-09-01	Compare percentages (%)	Production code(s)
		Bearing sizes								Unit price structure		
		d	D	B						USD		
		mm							USD			
41	22211 CC W33	55	100	25	N1	95	105	-	17.28	-	XSYC	
42	22211 CC/K W33	55	100	25	N1	95	105	-	17.28	-	XSYC	
43	* 22212 MB W33	60	110	28	N1	83	105	-	20.31	-	XSYC	
44	22212 MB/K W33	60	110	28	N1	83	105	-	20.31	-	XSYC	
45	22212 CA W33	60	110	28	N1	83	105	-	20.31	-	XSYC	
46	22212 CA/K W33	60	110	28	N1	83	105	-	20.31	-	XSYC	
47	22212 CC W33	60	110	28	N1	83	105	-	19.98	-	XSYC	
48	22212 CC/K W33	60	110	28	N1	83	105	-	19.98	-	XSYC	
49	22213 MB W33	65	120	31	N1	75	105	-	22.01	-	XSYC	
50	22213 MB/K W33	65	120	31	N1	75	105	-	22.01	-	XSYC	
51	22213 CA W33	65	120	31	N1	75	105	-	22.01	-	XSYC	
52	22213 CA/K W33	65	120	31	N1	75	105	-	22.01	-	XSYC	
53	22213 CC W33	65	120	31	N1	75	105	-	21.65	-	XSYC	
54	22213 CC/K W33	65	120	31	N1	75	105	-	21.65	-	XSYC	
55	* 22214 MB W33	70	125	31	N1	73	105	-	22.68	-	XSYC	
56	22214 MB/K W33	70	125	31	N1	73	105	-	22.68	-	XSYC	
57	22214 CA W33	70	125	31	N1	73	105	-	22.68	-	XSYC	
58	22214 CA/K W33	70	125	31	N1	73	105	-	22.68	-	XSYC	
59	22214 CC W33	70	125	31	N1	73	105	-	22.35	-	XSYC	
60	22214 CC/K W33	70	125	31	N1	73	105	-	22.35	-	XSYC	

<b>Remark</b>	Technical supplement	Precision	Grease
	Cage(s)		
	Steel - CC	Class 0 (JIS)	Nil
	Polymid - X		
Brass - CA, MB			

Qualified Sub-contractor(s)	Since
XSYC	2013
-	-
-	-

**SPHERICAL ROLLER BEARINGS**

**SERIES 222**

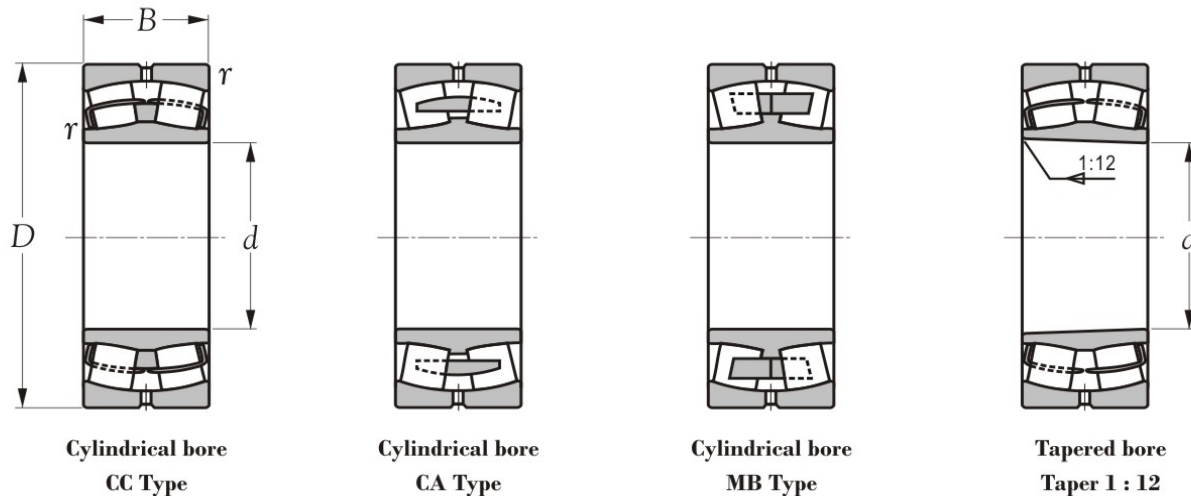

Items (20)	Data  Model nos.	Dimension			Packing method	Quantity  Min. order qty.  Pcs	Delivery  Days	Unit price structure  USD	2014-09-01  Unit price structure  USD	Compare percentages (%)	Production code(s)
		Bearing sizes									
		d	D	B							
		mm									
61	22215 MB W33	75	130	31	N1	68	105	-	23.69	-	XSYC
62	22215 MB/K W33	75	130	31	N1	68	105	-	23.69	-	XSYC
63	22215 CA W33	75	130	31	N1	68	105	-	23.69	-	XSYC
64	22215 CA/K W33	75	130	31	N1	68	105	-	23.69	-	XSYC
65	22215 CC W33	75	130	31	N1	68	105	-	23.01	-	XSYC
66	22215 CC/K W33	75	130	31	N1	68	105	-	23.01	-	XSYC
67	* 22216 MB W33	80	140	33	N1	63	105	-	27.09	-	XSYC
68	22216 MB/K W33	80	140	33	N1	63	105	-	27.09	-	XSYC
69	22216 CA W33	80	140	33	N1	63	105	-	27.09	-	XSYC
70	22216 CA/K W33	80	140	33	N1	63	105	-	27.09	-	XSYC
71	22216 CC W33	80	140	33	N1	63	105	-	26.41	-	XSYC
72	22216 CC/K W33	80	140	33	N1	63	105	-	26.41	-	XSYC
73	* 22217 MB W33	85	150	36	N1	55	105	-	28.78	-	XSYC
74	22217 MB/K W33	85	150	36	N1	55	105	-	28.78	-	XSYC
75	22217 CA W33	85	150	36	N1	55	105	-	28.78	-	XSYC
76	22217 CA/K W33	85	150	36	N1	55	105	-	28.78	-	XSYC
77	22217 CC W33	85	150	36	N1	55	105	-	27.09	-	XSYC
78	22217 CC/K W33	85	150	36	N1	55	105	-	27.75	-	XSYC
79	22218 MB W33	90	160	40	N1	48	105	-	32.49	-	XSYC
80	22218 MB/K W33	90	160	40	N1	48	105	-	33.16	-	XSYC

<b>Remark</b>	Technical supplement	Precision	Grease
	Cage(s)		
	Steel - CC	Class 0 (JIS)	Nil
	Polymid - X		
Brass - CA, MB			

Qualified Sub-contractor(s)	Since
XSYC	2013
-	-
-	-

**SPHERICAL ROLLER BEARINGS**

**SERIES 222**

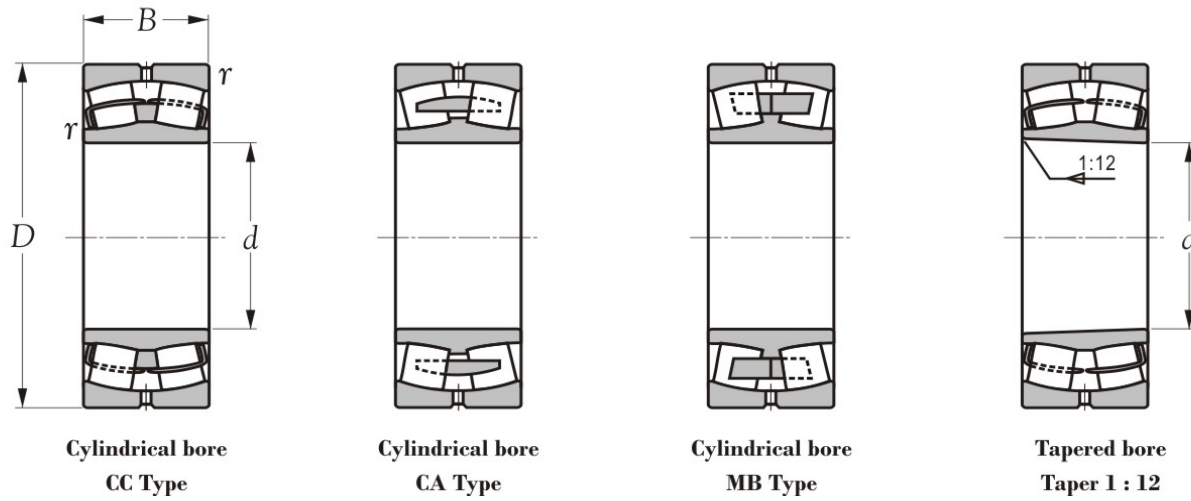

Items (20)	Data  Model nos.	Dimension			Packing method	Quantity  Min. order qty.  Pcs	Delivery  Days	-	2014-09-01	-	Production code(s)			
		Bearing sizes										Unit price structure  USD	Unit price structure  USD	Compare percentages (%)
		d	D	B										
		mm												
81	22218 CA W33	90	160	40	N1	48	105	-	32.49	-	XSYC			
82	22218 CA/K W33	90	160	40	N1	48	105	-	33.16	-	XSYC			
83	22218 CC W33	90	160	40	N1	48	105	-	31.83	-	XSYC			
84	22218 CC/K W33	90	160	40	N1	48	105	-	32.15	-	XSYC			
85	22219 MB W33	95	170	43	N1	43	105	-	37.23	-	XSYC			
86	22219 MB/K W33	95	170	43	N1	43	105	-	37.91	-	XSYC			
87	22219 CA W33	95	170	43	N1	43	105	-	37.23	-	XSYC			
88	22219 CA/K W33	95	170	43	N1	43	105	-	37.91	-	XSYC			
89	22219 CC W33	95	170	43	N1	43	105	-	36.56	-	XSYC			
90	22219 CC/K W33	95	170	43	N1	43	105	-	37.23	-	XSYC			
91	22220 MB W33	100	180	46	N1	38	105	-	44.00	-	XSYC			
92	22220 MB/K W33	100	180	46	N1	38	105	-	45.03	-	XSYC			
93	22220 CA W33	100	180	46	N1	38	105	-	44.00	-	XSYC			
94	22220 CA/K W33	100	180	46	N1	38	105	-	45.03	-	XSYC			
95	22220 CC W33	100	180	46	N1	38	105	-	44.00	-	XSYC			
96	22220 CC/K W33	100	180	46	N1	38	105	-	45.03	-	XSYC			
97	22222 MB W33	110	200	53	N1	28	105	-	60.94	-	XSYC			
98	22222 MB/K W33	110	200	53	N1	28	105	-	62.61	-	XSYC			
99	22222 CA W33	110	200	53	N1	28	105	-	60.94	-	XSYC			
100	22222 CA/K W33	110	200	53	N1	28	105	-	62.61	-	XSYC			

<b>Remark</b>	Technical supplement	Precision	Grease
	Cage(s)		
	Steel - CC	Class 0 (JIS)	Nil
	Polymid - X		
Brass - CA, MB			

Qualified Sub-contractor(s)	Since
XSYC	2013
-	-
-	-



SPHERICAL ROLLER BEARINGS

SERIES **222**

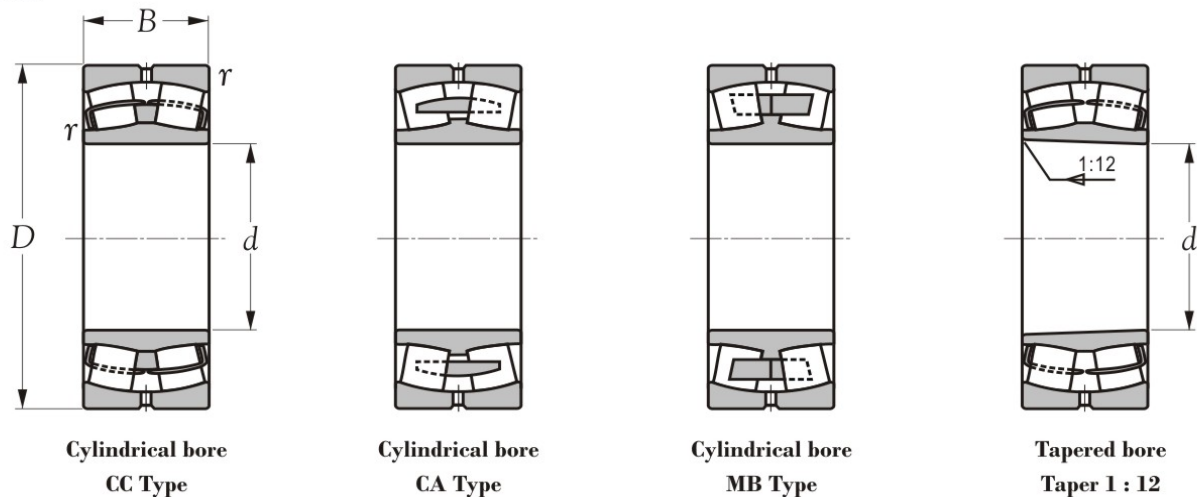

Items (20)	Data  Model nos.	Dimension			Packing method	Quantity  Min. order qty.  Pcs	Delivery  Days	-	Unit price structure  USD	2014-09-01	Compare percentages (%)	Production code(s)
		Bearing sizes								Unit price		
		d	D	B						structure		
		mm							USD			
101	22222 CC W33	110	200	53	N1	28	105	-	60.25	-	XSYC	
102	22222 CC/K W33	110	200	53	N1	28	105	-	61.94	-	XSYC	
103	22224 MB W33	120	215	58	N1	23	105	-	74.44	-	XSYC	
104	22224 MB/K W33	120	215	58	N1	23	105	-	76.15	-	XSYC	
105	22224 CA W33	120	215	58	N1	23	105	-	74.46	-	XSYC	
106	22224 CA/K W33	120	215	58	N1	23	105	-	76.15	-	XSYC	
107	22224 CC W33	120	215	58	N1	23	105	-	71.08	-	XSYC	
108	22224 CC/K W33	120	215	58	N1	23	105	-	72.78	-	XSYC	
109	22226 MB W33	130	230	64	N1	20	105	-	93.09	-	XSYC	
110	22226 MB/K W33	130	230	64	N1	20	105	-	94.78	-	XSYC	
111	22226 CA W33	130	230	64	N1	20	105	-	93.09	-	XSYC	
112	22226 CA/K W33	130	230	64	N1	20	105	-	94.78	-	XSYC	
113	22226 CC W33	130	230	64	N1	20	105	-	90.73	-	XSYC	
114	22226 CC/K W33	130	230	64	N1	20	105	-	92.40	-	XSYC	
115	22228 MB W33	140	250	68	N1	15	105	-	104.94	-	XSYC	
116	22228 MB/K W33	140	250	68	N1	15	105	-	108.31	-	XSYC	
117	22228 CA W33	140	250	68	N1	15	105	-	104.94	-	XSYC	
118	22228 CA/K W33	140	250	68	N1	15	105	-	108.31	-	XSYC	
119	22228 CC W33	140	250	68	N1	15	105	-	101.54	-	XSYC	
120	22228 CC/K W33	140	250	68	N1	15	105	-	104.94	-	XSYC	

<b>Remark</b>	Technical supplement	Precision	Grease
	Cage(s)		
	Steel - CC	Class 0 (JIS)	Nil
	Polymid - X		
Brass - CA, MB			

Qualified Sub-contractor(s)	Since
XSYC	2013
-	-
-	-



SPHERICAL ROLLER BEARINGS

SERIES **222**

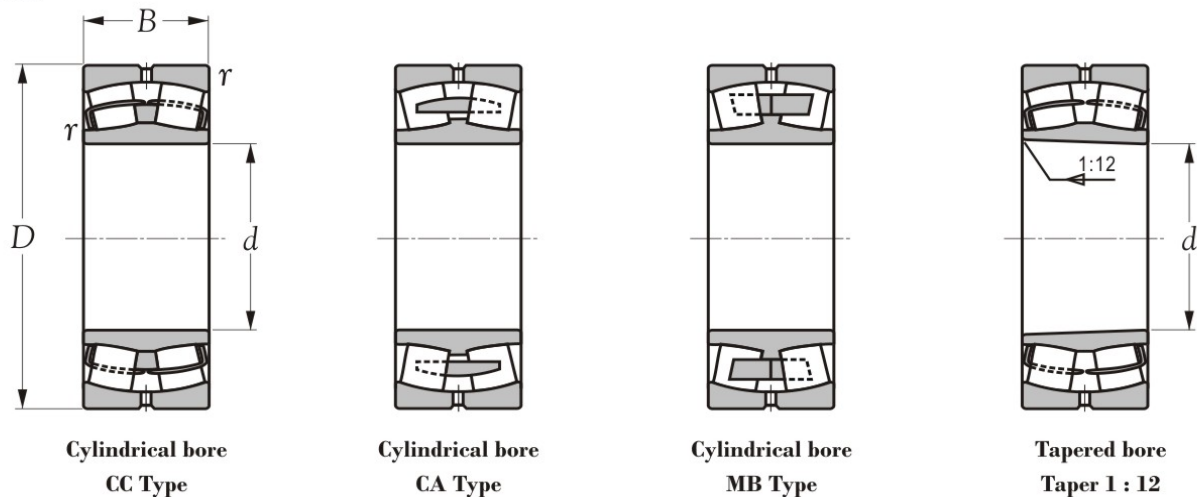

Items (6)	Data  Model nos.	Dimension			Packing method	Quantity  Min. order qty.  Pcs	Delivery  Days	-	2014-09-01	Compare percentages (%)	Production code(s)		
		Bearing sizes										Unit price structure  USD	Unit price structure  USD
		d	D	B									
		mm											
121	22230 MB W33	150	270	73	N1	13	105	-	121.85	-	XSYC		
122	22230 MB/K W33	150	270	73	N1	13	105	-	125.25	-	XSYC		
123	22230 CA W33	150	270	73	N1	13	105	-	121.85	-	XSYC		
124	22230 CA/K W33	150	270	73	N1	13	105	-	125.25	-	XSYC		
125	22230 CC W33	150	270	73	N1	13	105	-	118.48	-	XSYC		
126	22230 CC/K W33	150	270	73	N1	13	105	-	121.85	-	XSYC		

<b>Remark</b>	Technical supplement	Precision	Grease
	Cage(s)		
	Steel - CC	Class 0 (JIS)	Nil
	Polymid - X		
Brass - CA, MB			

Qualified Sub-contractor(s)	Since
XSYC	2013
-	-
-	-

**SPHERICAL ROLLER BEARINGS**

**SERIES 223**

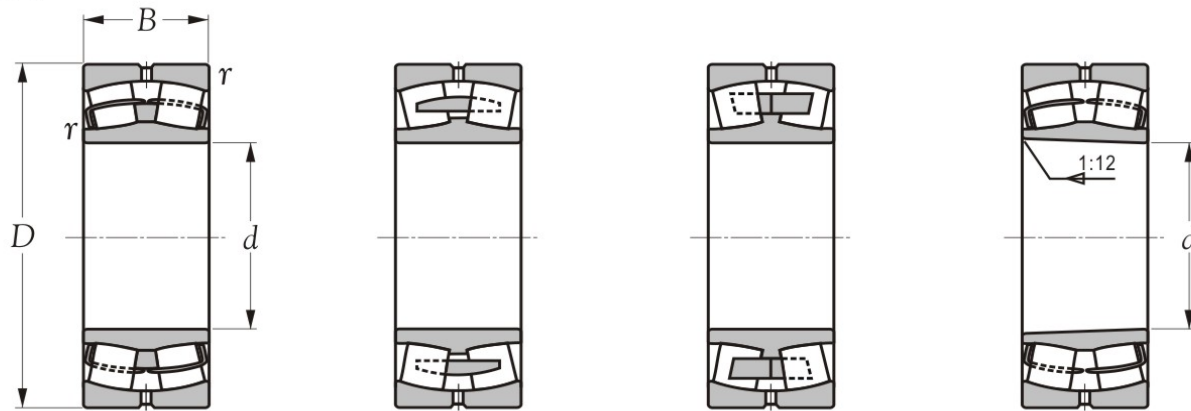

Cylindrical bore  
CC Type

Cylindrical bore  
CA Type

Cylindrical bore  
MB Type

Tapered bore  
Taper 1 : 12

Items (20)	Data  Model nos.	Dimension			Packing method	Quantity  Min. order qty.  Pcs	Delivery  Days	-	Unit price structure  USD	2014-09-01	Compare percentages (%)	Production code(s)
		Bearing sizes								Unit price structure		
		d	D	B						USD		
		mm							USD			
1	22308 MB W33	40	90	33	N1	90	105	-	16.25	-	XSYC	
2	22308 MB/K W33	40	90	33	N1	90	105	-	16.59	-	XSYC	
3	22308 CA W33	40	90	33	N1	90	105	-	16.25	-	XSYC	
4	22308 CA/K W33	40	90	33	N1	90	105	-	16.59	-	XSYC	
5	22308 CC W33	40	90	33	N1	90	105	-	16.25	-	XSYC	
6	22308 CC/K W33	40	90	33	N1	90	105	-	16.59	-	XSYC	
7	22309 MB W33	45	100	36	N1	78	105	-	18.61	-	XSYC	
8	22309 MB/K W33	45	100	36	N1	78	105	-	18.95	-	XSYC	
9	22309 CA W33	45	100	36	N1	78	105	-	18.61	-	XSYC	
10	22309 CA/K W33	45	100	36	N1	78	105	-	18.95	-	XSYC	
11	22309 CC W33	45	100	36	N1	78	105	-	18.61	-	XSYC	
12	22309 CC/K W33	45	100	36	N1	78	105	-	18.61	-	XSYC	
13	22310 MB W33	50	110	40	N1	70	105	-	22.01	-	XSYC	
14	22310 MB/K W33	50	110	40	N1	70	105	-	22.35	-	XSYC	
15	22310 CA W33	50	110	40	N1	70	105	-	22.01	-	XSYC	
16	22310 CA/K W33	50	110	40	N1	70	105	-	22.35	-	XSYC	
17	22310 CC W33	50	110	40	N1	70	105	-	21.33	-	XSYC	
18	22310 CC/K W33	50	110	40	N1	70	105	-	21.65	-	XSYC	
19	22311 MB W33	55	120	43	N1	63	105	-	25.39	-	XSYC	
20	22311 MB/K W33	55	120	43	N1	63	105	-	26.06	-	XSYC	

<b>Remark</b>	Technical supplement	Precision	Grease
	Cage(s)		
	Steel - CC	Class 0 (JIS)	Nil
	Polymid - X		
Brass - CA, MB			

Qualified Sub-contractor(s)	Since
XSYC	2013
-	-
-	-

**SPHERICAL ROLLER BEARINGS**

**SERIES 223**

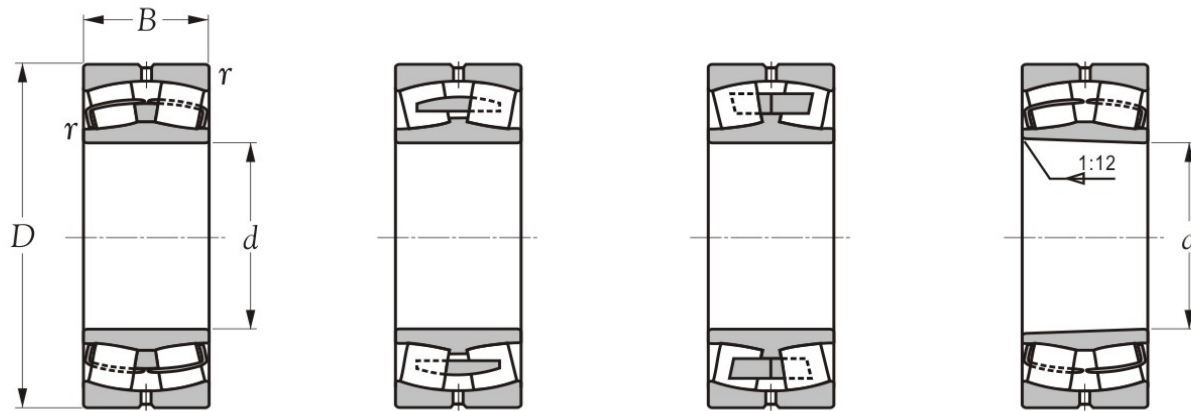

Cylindrical bore  
CC Type

Cylindrical bore  
CA Type

Cylindrical bore  
MB Type

Tapered bore  
Taper 1 : 12

Items (20)	Data  Model nos.	Dimension			Packing method	Quantity  Min. order qty.  Pcs	Delivery  Days	-	Unit price structure  USD	2014-09-01	Compare percentages (%)	Production code(s)
		Bearing sizes								Unit price structure		
		d	D	B						USD		
		mm							USD			
21	22311 CA W33	55	120	43	N1	63	105	-	25.39	-	XSYC	
22	22311 CA/K W33	55	120	43	N1	63	105	-	26.06	-	XSYC	
23	22311 CC W33	55	120	43	N1	63	105	-	24.71	-	XSYC	
24	22311 CC/K W33	55	120	43	N1	63	105	-	25.39	-	XSYC	
25	22312 MB W33	60	130	46	N1	55	105	-	28.78	-	XSYC	
26	22312 MB/K W33	60	130	46	N1	55	105	-	29.45	-	XSYC	
27	22312 CA W33	60	130	46	N1	55	105	-	28.78	-	XSYC	
28	22312 CA/K W33	60	130	46	N1	55	105	-	29.45	-	XSYC	
29	22312 CC W33	60	130	46	N1	55	105	-	28.09	-	XSYC	
30	22312 CC/K W33	60	130	46	N1	55	105	-	28.78	-	XSYC	
31	22313 MB W33	65	140	48	N1	48	105	-	33.16	-	XSYC	
32	22313 MB/K W33	65	140	48	N1	48	105	-	33.85	-	XSYC	
33	22313 CA W33	65	140	48	N1	48	105	-	33.16	-	XSYC	
34	22313 CA/K W33	65	140	48	N1	48	105	-	33.85	-	XSYC	
35	22313 CC W33	65	140	48	N1	48	105	-	32.15	-	XSYC	
36	22313 CC/K W33	65	140	48	N1	48	105	-	32.83	-	XSYC	
37	22314 MB W33	70	150	51	N1	43	105	-	35.54	-	XSYC	
38	22314 MB/K W33	70	150	51	N1	43	105	-	36.23	-	XSYC	
39	22314 CA W33	70	150	51	N1	43	105	-	35.54	-	XSYC	
40	22314 CA/K W33	70	150	51	N1	43	105	-	36.23	-	XSYC	

<b>Remark</b>	Technical supplement	Precision	Grease
	Cage(s)		
	Steel - CC	Class 0 (JIS)	Nil
	Polymid - X		
Brass - CA, MB			

Qualified Sub-contractor(s)	Since
XSYC	2013
-	-
-	-

**SPHERICAL ROLLER BEARINGS**

**SERIES 223**

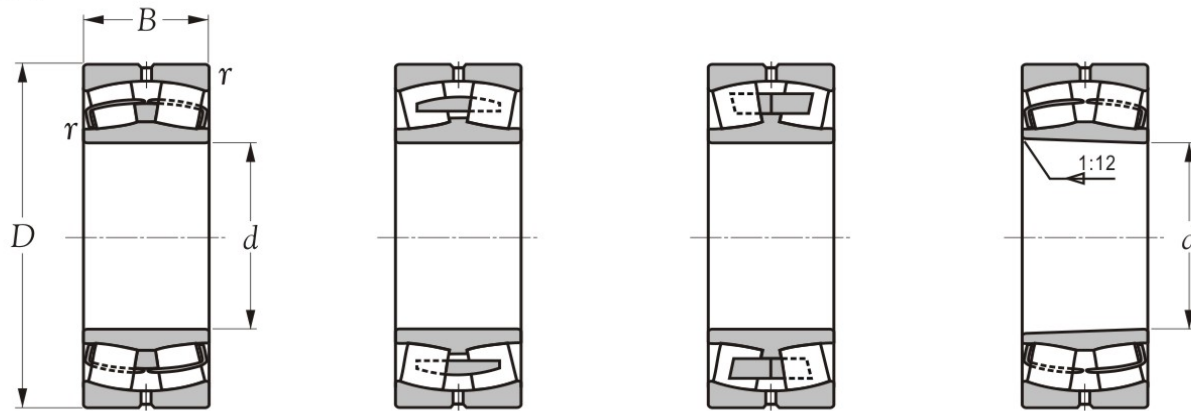

Cylindrical bore  
CC Type

Cylindrical bore  
CA Type

Cylindrical bore  
MB Type

Tapered bore  
Taper 1 : 12

Items (20)	Data  Model nos.	Dimension			Packing method	Quantity  Min. order qty.  Pcs	Delivery  Days	-	Unit price structure  USD	2014-09-01	Compare percentages (%)	Production code(s)
		Bearing sizes								Unit price structure		
		d	D	B						USD		
41	22314 CC W33	70	150	51	N1	43	105	-	34.86	-	XSYC	
42	22314 CC/K W33	70	150	51	N1	43	105	-	35.54	-	XSYC	
43	22315 MB W33	75	160	55	N1	35	105	-	45.70	-	XSYC	
44	22315 MB/K W33	75	160	55	N1	35	105	-	46.70	-	XSYC	
45	22315 CA W33	75	160	55	N1	35	105	-	45.70	-	XSYC	
46	22315 CA/K W33	75	160	55	N1	35	105	-	46.70	-	XSYC	
47	22315 CC W33	75	160	55	N1	35	105	-	45.03	-	XSYC	
48	22315 CC/K W33	75	160	55	N1	35	105	-	45.70	-	XSYC	
49	22316 MB W33	80	170	58	N1	33	105	-	52.46	-	XSYC	
50	22316 MB/K W33	80	170	58	N1	33	105	-	53.48	-	XSYC	
51	22316 CA W33	80	170	58	N1	33	105	-	52.46	-	XSYC	
52	22316 CA/K W33	80	170	58	N1	33	105	-	53.48	-	XSYC	
53	22316 CC W33	80	170	58	N1	33	105	-	50.78	-	XSYC	
54	22316 CC/K W33	80	170	58	N1	33	105	-	51.80	-	XSYC	
55	22317 MB W33	85	180	60	N1	28	105	-	59.24	-	XSYC	
56	22317 MB/K W33	85	180	60	N1	28	105	-	60.94	-	XSYC	
57	22317 CA W33	85	180	60	N1	28	105	-	59.24	-	XSYC	
58	22317 CA/K W33	85	180	60	N1	28	105	-	60.94	-	XSYC	
59	22317 CC W33	85	180	60	N1	28	105	-	57.54	-	XSYC	
60	22317 CC/K W33	85	180	60	N1	28	105	-	59.24	-	XSYC	

<b>Remark</b>	Technical supplement	Precision	Grease
	Cage(s)		
	Steel - CC	Class 0 (JIS)	Nil
	Polymid - X		
Brass - CA, MB			

Qualified Sub-contractor(s)	Since
XSYC	2013
-	-
-	-

SPHERICAL ROLLER BEARINGS

SERIES **223**

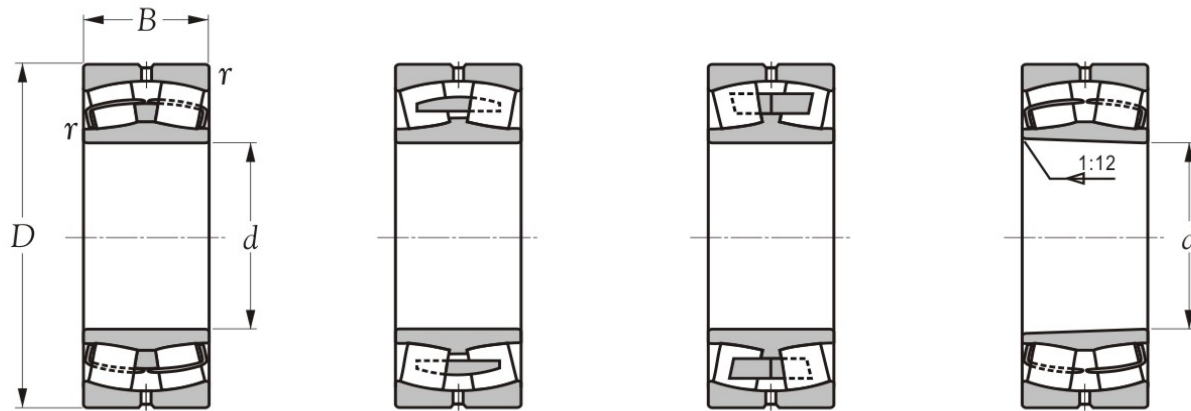

Cylindrical bore  
CC Type

Cylindrical bore  
CA Type

Cylindrical bore  
MB Type

Tapered bore  
Taper 1 : 12

Items (20)	Data  Model nos.	Dimension			Packing method	Quantity  Min. order qty.  Pcs	Delivery  Days	-	Unit price structure  USD	2014-09-01	Compare percentages (%)	Production code(s)
		Bearing sizes								Unit price structure		
		d	D	B						USD		
61	22318 MB W33	90	190	64	N1	25	105	-	62.61	-	XSYC	
62	22318 MB/K W33	90	190	64	N1	25	105	-	64.31	-	XSYC	
63	22318 CA W33	90	190	64	N1	25	105	-	62.61	-	XSYC	
64	22318 CA/K W33	90	190	64	N1	25	105	-	64.31	-	XSYC	
65	22318 CC W33	90	190	64	N1	25	105	-	60.94	-	XSYC	
66	22318 CC/K W33	90	190	64	N1	25	105	-	62.61	-	XSYC	
67	22319 MB W33	95	200	67	N1	23	105	-	76.15	-	XSYC	
68	22319 MB/K W33	95	200	67	N1	23	105	-	77.85	-	XSYC	
69	22319 CA W33	95	200	67	N1	23	105	-	76.15	-	XSYC	
70	22319 CA/K W33	95	200	67	N1	23	105	-	77.85	-	XSYC	
71	22319 CC W33	95	200	67	N1	23	105	-	72.78	-	XSYC	
72	22319 CC/K W33	95	200	67	N1	23	105	-	74.46	-	XSYC	
73	22320 MB W33	100	215	73	N1	20	105	-	91.39	-	XSYC	
74	22320 MB/K W33	100	215	73	N1	20	105	-	93.09	-	XSYC	
75	22320 CA W33	100	215	73	N1	20	105	-	91.39	-	XSYC	
76	22320 CA/K W33	100	215	73	N1	20	105	-	93.09	-	XSYC	
77	22320 CC W33	100	215	73	N1	20	105	-	88.00	-	XSYC	
78	22320 CC/K W33	100	215	73	N1	20	105	-	89.70	-	XSYC	
79	22322 MB W33	110	240	80	N1	15	105	-	128.63	-	XSYC	
80	22322 MB/K W33	110	240	80	N1	15	105	-	132.01	-	XSYC	

Remark	Technical supplement		
	Cage(s)	Precision	Grease
	Steel - CC Polyimid - X Brass - CA, MB	Class 0 (JIS)	Nil

Qualified Sub-contractor(s)	Since
XSYC	2013
-	-
-	-

**SPHERICAL ROLLER BEARINGS**

**SERIES 223**

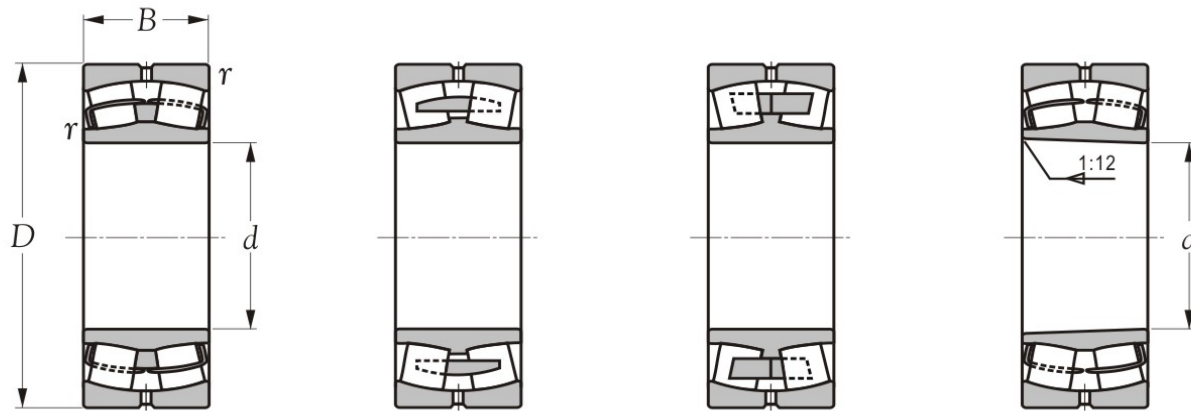

Cylindrical bore  
CC Type

Cylindrical bore  
CA Type

Cylindrical bore  
MB Type

Tapered bore  
Taper 1 : 12

Items (10)	Data  Model nos.	Dimension			Packing method	Quantity  Min. order qty.  Pcs	Delivery  Days	-	Unit price structure  USD	2014-09-01	Compare percentages (%)	Production code(s)
		Bearing sizes								Unit price		
		d	D	B						structure		
		mm							USD			
81	22322 CA W33	110	240	80	N1	15	105	-	128.63	-	XSYC	
82	22322 CA/K W33	110	240	80	N1	15	105	-	132.01	-	XSYC	
83	22322 CC W33	110	240	80	N1	15	105	-	128.63	-	XSYC	
84	22322 CC/K W33	110	240	80	N1	15	105	-	132.01	-	XSYC	
85	22324 MB W33	120	260	86	N1	10	105	-	169.24	-	XSYC	
86	22324 MB/K W33	120	260	86	N1	10	105	-	176.01	-	XSYC	
87	22324 CA W33	120	260	86	N1	10	105	-	169.24	-	XSYC	
88	22324 CA/K W33	120	260	86	N1	10	105	-	176.01	-	XSYC	
89	22324 CC W33	120	260	86	N1	10	105	-	169.24	-	XSYC	
90	22324 CC/K W33	120	260	86	N1	10	105	-	176.01	-	XSYC	

<b>Remark</b>	Technical supplement	Precision	Grease
	Cage(s)		
	Steel - CC	Class 0 (JIS)	Nil
	Polymid - X		
Brass - CA, MB			

Qualified Sub-contractor(s)	Since
XSYC	2013
-	-
-	-

**SPHERICAL ROLLER BEARINGS**  
**SERIES 230**

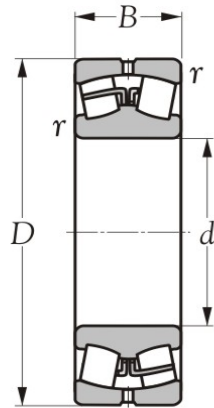

Cylindrical bore

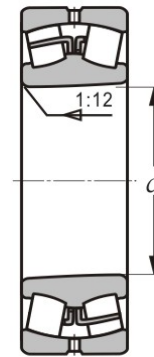

Tapered bore

Items (20)	Data  Model nos.	Dimension			Packing method	Quantity  Min. order qty.  Pcs	Delivery  Days	-	2014-09-01	Compare percentages (%)	Production code(s)		
		Bearing sizes										Unit price structure  USD	Unit price structure  USD
		d	D	B									
		mm											
1	23022 MB W33	110	170	45	N1	38	105	-	50.78	-	XSYC		
2	23022 MB/K W33	110	170	45	N1	38	105	-	50.78	-	XSYC		
3	23022 CA W33	110	170	45	N1	38	105	-	50.78	-	XSYC		
4	23022 CA/K W33	110	170	45	N1	38	105	-	50.78	-	XSYC		
5	23022 CC W33	110	170	45	N1	38	105	-	50.78	-	XSYC		
6	23022 CC/K W33	110	170	45	N1	38	105	-	50.78	-	XSYC		
7	23024 MB W33	120	180	46	N1	33	105	-	54.16	-	XSYC		
8	23024 MB/K W33	120	180	46	N1	33	105	-	54.16	-	XSYC		
9	23024 CA W33	120	180	46	N1	33	105	-	54.16	-	XSYC		
10	23024 CA/K W33	120	180	46	N1	33	105	-	54.16	-	XSYC		
11	23024 CC W33	120	180	46	N1	33	105	-	54.16	-	XSYC		
12	23024 CC/K W33	120	180	46	N1	33	105	-	54.16	-	XSYC		
13	23026 MB W33	130	200	52	N1	28	105	-	59.24	-	XSYC		
14	23026 MB/K W33	130	200	52	N1	28	105	-	59.24	-	XSYC		
15	23026 CA W33	130	200	52	N1	28	105	-	59.24	-	XSYC		
16	23026 CA/K W33	130	200	52	N1	28	105	-	59.24	-	XSYC		
17	23026 CC W33	130	200	52	N1	28	105	-	59.24	-	XSYC		
18	23026 CC/K W33	130	200	52	N1	28	105	-	59.24	-	XSYC		
19	23028 MB W33	140	210	53	N1	25	105	-	62.61	-	XSYC		
20	23028 MB/K W33	140	210	53	N1	25	105	-	62.61	-	XSYC		

Remark	Technical supplement		
	Cage(s)	Precision	Grease
	Steel - <b>CC</b> Polyimid - <b>X</b> Brass - <b>CA, MB</b>	<b>Class 0 (JIS)</b>	Nil

Qualified Sub-contractor(s)	Since
XSYC	2013
-	-
-	-



**SPHERICAL ROLLER BEARINGS**  
**SERIES 230**

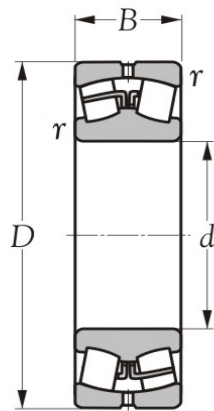

Cylindrical bore

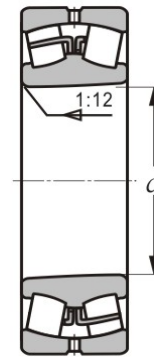

Tapered bore

Items (16)	Data  Model nos.	Dimension			Packing method	Quantity  Min. order qty.  Pcs	Delivery  Days	Unit price structure  USD	2014-09-01 Unit price structure  USD	Compare percentages (%)	Production code(s)
		Bearing sizes									
		d	D	B							
		mm									
21	23028 CA W33	140	210	53	N1	25	105	-	62.61	-	XSYC
22	23028 CA/K W33	140	210	53	N1	25	105	-	62.61	-	XSYC
23	23028 CC W33	140	210	53	N1	25	105	-	60.94	-	XSYC
24	23028 CC/K W33	140	210	53	N1	25	105	-	62.61	-	XSYC
25	23030 MB W33	150	225	56	N1	20	105	-	84.63	-	XSYC
26	23030 MB/K W33	150	225	56	N1	20	105	-	84.63	-	XSYC
27	23030 CA W33	150	225	56	N1	20	105	-	84.63	-	XSYC
28	23030 CA/K W33	150	225	56	N1	20	105	-	84.63	-	XSYC
29	23030 CC W33	150	225	56	N1	20	105	-	84.63	-	XSYC
30	23030 CC/K W33	150	225	56	N1	20	105	-	84.63	-	XSYC
31	23032 MB W33	160	240	60	N1	18	105	-	101.54	-	XSYC
32	23032 MB/K W33	160	240	60	N1	18	105	-	101.54	-	XSYC
33	23032 CA W33	160	240	60	N1	18	105	-	101.54	-	XSYC
34	23032 CA/K W33	160	240	60	N1	18	105	-	101.54	-	XSYC
35	23032 CC W33	160	240	60	N1	18	105	-	104.94	-	XSYC
36	23032 CC/K W33	160	240	60	N1	18	105	-	108.31	-	XSYC

Remark	Technical supplement		
	Cage(s)	Precision	Grease
	Steel - <b>CC</b> Polyimid - <b>X</b> Brass - <b>CA, MB</b>	<b>Class 0 (JIS)</b>	Nil

Qualified Sub-contractor(s)	Since
XSYC	2013
-	-
-	-



**SPHERICAL ROLLER BEARINGS**  
**SERIES 231**

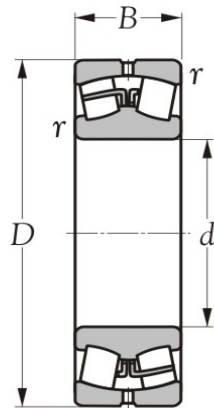

Cylindrical bore

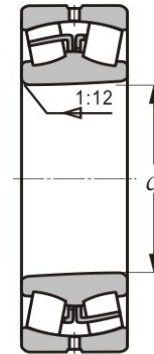

Tapered bore

Items (20)	Data  Model nos.	Dimension			Packing method	Quantity  Min. order qty.  Pcs	Delivery  Days	-	2014-09-01	Compare percentages (%)	Production code(s)		
		Bearing sizes										Unit price structure  USD	Unit price structure  USD
		d	D	B									
		mm											
1	23120 MB W33	100	165	52	N1	35	105	-	67.69	-	XSYC		
2	23120 MB/K W33	100	165	52	N1	35	105	-	67.69	-	XSYC		
3	23120 CA W33	100	165	52	N1	35	105	-	67.69	-	XSYC		
4	23120 CA/K W33	100	165	52	N1	35	105	-	67.69	-	XSYC		
5	23120 CC W33	100	165	52	N1	35	105	-	67.69	-	XSYC		
6	23120 CC/K W33	100	165	52	N1	35	105	-	67.69	-	XSYC		
7	23122 MB W33	110	180	56	N1	28	105	-	76.15	-	XSYC		
8	23122 MB/K W33	110	180	56	N1	28	105	-	76.15	-	XSYC		
9	23122 CA W33	110	180	56	N1	28	105	-	76.15	-	XSYC		
10	23122 CA/K W33	110	180	56	N1	28	105	-	76.15	-	XSYC		
11	23122 CC W33	110	180	56	N1	28	105	-	76.15	-	XSYC		
12	23122 CC/K W33	110	180	56	N1	28	105	-	76.15	-	XSYC		
13	23124 MB W33	120	200	62	N1	23	105	-	88.00	-	XSYC		
14	23124 MB/K W33	120	200	62	N1	23	105	-	88.00	-	XSYC		
15	23124 CA W33	120	200	62	N1	23	105	-	88.00	-	XSYC		
16	23124 CA/K W33	120	200	62	N1	23	105	-	88.00	-	XSYC		
17	23124 CC W33	120	200	62	N1	23	105	-	88.00	-	XSYC		
18	23124 CC/K W33	120	200	62	N1	23	105	-	88.00	-	XSYC		
19	23126 MB W33	130	210	64	N1	20	105	-	101.54	-	XSYC		
20	23126 MB/K W33	130	210	64	N1	20	105	-	101.54	-	XSYC		

Remark	Technical supplement		
	Cage(s)	Precision	Grease
	Steel - <b>CC</b> Polyamid - <b>X</b> Brass - <b>CA, MB</b>	<b>Class 0 (JIS)</b>	Nil

Qualified Sub-contractor(s)	Since
XSYC	2013
-	-
-	-

**SPHERICAL ROLLER BEARINGS**  
**SERIES 231**

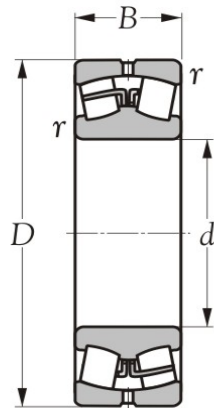

Cylindrical bore

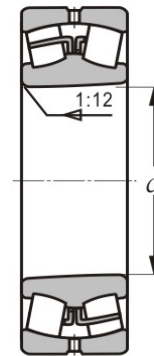

Tapered bore

Items (20)	Data  Model nos.	Dimension			Packing method	Quantity  Min. order qty.  Pcs	Delivery  Days	-	2014-09-01	Compare percentages (%)	Production code(s)		
		Bearing sizes										Unit price structure  USD	Unit price structure  USD
		d	D	B									
		mm											
21	23126 CA W33	130	210	64	N1	20	105	-	101.54	-	XSYC		
22	23126 CA/K W33	130	210	64	N1	20	105	-	101.54	-	XSYC		
23	23126 CC W33	130	210	64	N1	20	105	-	108.31	-	XSYC		
24	23126 CC/K W33	130	210	64	N1	20	105	-	111.70	-	XSYC		
25	23128 MB W33	140	225	68	N1	18	105	-	125.25	-	XSYC		
26	23128 MB/K W33	140	225	68	N1	18	105	-	125.25	-	XSYC		
27	23128 CA W33	140	225	68	N1	18	105	-	125.25	-	XSYC		
28	23128 CA/K W33	140	225	68	N1	18	105	-	125.25	-	XSYC		
29	23128 CC W33	140	225	68	N1	18	105	-	132.01	-	XSYC		
30	23128 CC/K W33	140	225	68	N1	18	105	-	135.39	-	XSYC		
31	23130 MB W33	150	250	80	N1	13	105	-	142.16	-	XSYC		
32	23130 MB/K W33	150	250	80	N1	13	105	-	142.16	-	XSYC		
33	23130 CA W33	150	250	80	N1	13	105	-	142.16	-	XSYC		
34	23130 CA/K W33	150	250	80	N1	13	105	-	142.16	-	XSYC		
35	23130 CC W33	150	250	80	N1	13	105	-	148.94	-	XSYC		
36	23130 CC/K W33	150	250	80	N1	13	105	-	148.94	-	XSYC		
37	23132 MB W33	160	270	86	N1	10	105	-	162.48	-	XSYC		
38	23132 MB/K W33	160	270	86	N1	10	105	-	162.48	-	XSYC		
39	23132 CA W33	160	270	86	N1	10	105	-	162.48	-	XSYC		
40	23132 CA/K W33	160	270	86	N1	10	105	-	162.48	-	XSYC		

Remark	Technical supplement		
	Cage(s)	Precision	Grease
	Steel - <b>CC</b> Polyimid - <b>X</b> Brass - <b>CA, MB</b>	<b>Class 0 (JIS)</b>	Nil

Qualified Sub-contractor(s)	Since
XSYC	2013
-	-
-	-

SPHERICAL ROLLER BEARINGS  
SERIES **231**

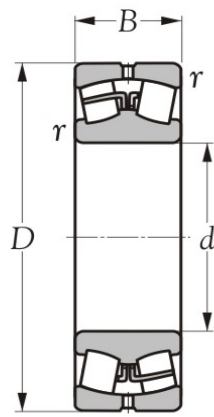

Cylindrical bore

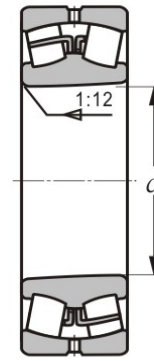

Tapered bore

Items (2)	Data  Model nos.	Dimension			Packing method	Quantity  Min. order qty.  Pcs	Delivery  Days	-	2014-09-01	-	2014-09-01	Compare percentages (%)	Production code(s)		
		Bearing sizes												Unit price structure	Unit price structure
		d	D	B											
		mm													
41	23132 CC W33	160	270	86	N1	10	105	-		169.24	-	XSYC			
42	23132 CC/K W33	160	270	86	N1	10	105	-		176.01	-	XSYC			

<b>Remark</b>	Technical supplement	Precision	Grease
	Cage(s)		
	Steel - <b>CC</b>	<b>Class 0 (JIS)</b>	Nil
	Polymid - <b>X</b>		
Brass - <b>CA, MB</b>			

Qualified Sub-contractor(s)	Since
XSYC	2013
-	-
-	-

**SPHERICAL ROLLER BEARINGS**  
**SERIES 232**

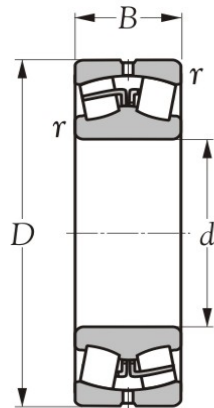

Cylindrical bore

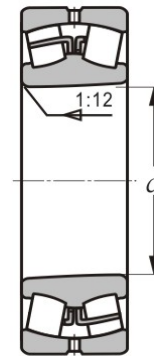

Tapered bore

Items (20)	Data  Model nos.	Dimension			Packing method	Quantity  Min. order qty.  Pcs	Delivery  Days	-	2014-09-01	Compare percentages (%)	Production code(s)		
		Bearing sizes										Unit price structure  USD	Unit price structure  USD
		d	D	B									
		mm											
1	23218 MB W33	90	160	52.4	N1	28	105	-	71.08	-	XSYC		
2	23218 MB/K W33	90	160	52.4	N1	28	105	-	71.08	-	XSYC		
3	23218 CA W33	90	160	52.4	N1	28	105	-	71.08	-	XSYC		
4	23218 CA/K W33	90	160	52.4	N1	28	105	-	71.08	-	XSYC		
5	23218 CC W33	90	160	52.4	N1	28	105	-	71.08	-	XSYC		
6	23218 CC/K W33	90	160	52.4	N1	28	105	-	71.08	-	XSYC		
7	23220 MB W33	100	180	60.3	N1	25	105	-	77.85	-	XSYC		
8	23220 MB/K W33	100	180	60.3	N1	25	105	-	77.85	-	XSYC		
9	23220 CA W33	100	180	60.3	N1	25	105	-	77.85	-	XSYC		
10	23220 CA/K W33	100	180	60.3	N1	25	105	-	77.85	-	XSYC		
11	23220 CC W33	100	180	60.3	N1	25	105	-	77.85	-	XSYC		
12	23220 CC/K W33	100	180	60.3	N1	25	105	-	77.85	-	XSYC		
13	23222 MB W33	110	200	69.8	N1	18	105	-	104.94	-	XSYC		
14	23222 MB/K W33	110	200	69.8	N1	18	105	-	104.94	-	XSYC		
15	23222 CA W33	110	200	69.8	N1	18	105	-	104.94	-	XSYC		
16	23222 CA/K W33	110	200	69.8	N1	18	105	-	104.94	-	XSYC		
17	23222 CC W33	110	200	69.8	N1	18	105	-	108.31	-	XSYC		
18	23222 CC/K W33	110	200	69.8	N1	18	105	-	108.31	-	XSYC		
19	23224 MB W33	120	215	76	N1	13	105	-	128.63	-	XSYC		
20	23224 MB/K W33	120	215	76	N1	13	105	-	128.63	-	XSYC		

Remark	Technical supplement		
	Cage(s)	Precision	Grease
	Steel - <b>CC</b> Polyimid - <b>X</b> Brass - <b>CA, MB</b>	<b>Class 0</b> (JIS)	Nil

Qualified Sub-contractor(s)	Since
XSYC	2013
-	-
-	-

**SPHERICAL ROLLER BEARINGS**  
**SERIES 232**

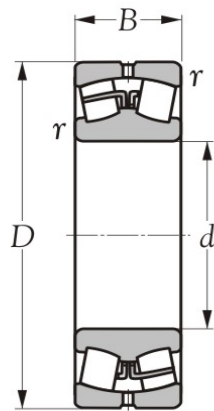

Cylindrical bore

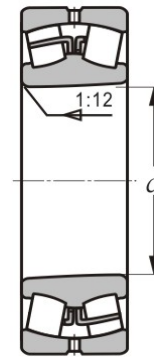

Tapered bore

Items (16)	Data  Model nos.	Dimension			Packing method	Quantity  Min. order qty.  Pcs	Delivery  Days	-	2014-09-01	Compare percentages (%)	Production code(s)		
		Bearing sizes										Unit price structure  USD	Unit price structure  USD
		d	D	B									
		mm											
21	23224 CA W33	120	215	76	N1	13	105	-	128.63	-	XSYC		
22	23224 CA/K W33	120	215	76	N1	13	105	-	128.63	-	XSYC		
23	23224 CC W33	120	215	76	N1	13	105	-	132.01	-	XSYC		
24	23224 CC/K W33	120	215	76	N1	13	105	-	132.01	-	XSYC		
25	23226 MB W33	130	230	80	N1	13	105	-	152.31	-	XSYC		
26	23226 MB/K W33	130	230	80	N1	13	105	-	152.31	-	XSYC		
27	23226 CA W33	130	230	80	N1	13	105	-	152.31	-	XSYC		
28	23226 CA/K W33	130	230	80	N1	13	105	-	152.31	-	XSYC		
29	23226 CC W33	130	230	80	N1	13	105	-	155.70	-	XSYC		
30	23226 CC/K W33	130	230	80	N1	13	105	-	155.70	-	XSYC		
31	23228 MB W33	140	250	88	N1	10	105	-	169.24	-	XSYC		
32	23228 MB/K W33	140	250	88	N1	10	105	-	169.24	-	XSYC		
33	23228 CA W33	140	250	88	N1	10	105	-	169.24	-	XSYC		
34	23228 CA/K W33	140	250	88	N1	10	105	-	169.24	-	XSYC		
35	23228 CC W33	140	250	88	N1	10	105	-	176.01	-	XSYC		
36	23228 CC/K W33	140	250	88	N1	10	105	-	176.01	-	XSYC		

Remark	Technical supplement		
	Cage(s)	Precision	Grease
	Steel - <b>CC</b> Polyimid - <b>X</b> Brass - <b>CA, MB</b>	<b>Class 0 (JIS)</b>	Nil

Qualified Sub-contractor(s)	Since
XSYC	2013
-	-
-	-

**SPHERICAL ROLLER BEARINGS**  
**SERIES 240**

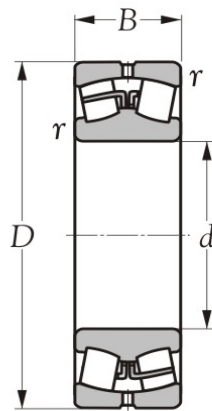

Cylindrical bore

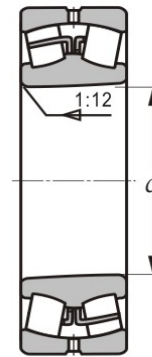

Tapered bore

Items (20)	Data  Model nos.	Dimension			Packing method	Quantity  Min. order qty.  Pcs	Delivery  Days	-	2014-09-01	Compare percentages (%)	Production code(s)		
		Bearing sizes										Unit price structure  USD	Unit price structure  USD
		d	D	B									
		mm											
1	24022 MB W33	110	170	60	N1	23	105	-	84.63	-	XSYC		
2	24022 MB/K W33	110	170	60	N1	23	105	-	84.63	-	XSYC		
3	24022 CA W33	110	170	60	N1	23	105	-	84.63	-	XSYC		
4	24022 CA/K W33	110	170	60	N1	23	105	-	84.63	-	XSYC		
5	24022 CC W33	110	170	60	N1	23	105	-	88.00	-	XSYC		
6	24022 CC/K W33	110	170	60	N1	23	105	-	88.00	-	XSYC		
7	24024 MB W33	120	180	60	N1	20	105	-	91.39	-	XSYC		
8	24024 MB/K W33	120	180	60	N1	20	105	-	91.39	-	XSYC		
9	24024 CA W33	120	180	60	N1	20	105	-	91.39	-	XSYC		
10	24024 CA/K W33	120	180	60	N1	20	105	-	91.39	-	XSYC		
11	24024 CC W33	120	180	60	N1	20	105	-	94.78	-	XSYC		
12	24024 CC/K W33	120	180	60	N1	20	105	-	98.16	-	XSYC		
13	24026 MB W33	130	200	69	N1	18	105	-	111.70	-	XSYC		
14	24026 MB/K W33	130	200	69	N1	18	105	-	111.70	-	XSYC		
15	24026 CA W33	130	200	69	N1	18	105	-	111.70	-	XSYC		
16	24026 CA/K W33	130	200	69	N1	18	105	-	111.70	-	XSYC		
17	24026 CC W33	130	200	69	N1	18	105	-	115.08	-	XSYC		
18	24026 CC/K W33	130	200	69	N1	18	105	-	118.48	-	XSYC		
19	24028 MB W33	140	210	69	N1	15	105	-	121.85	-	XSYC		
20	24028 MB/K W33	140	210	69	N1	15	105	-	121.85	-	XSYC		

Remark	Technical supplement		
	Cage(s)	Precision	Grease
	Steel - <b>CC</b> Polymid - <b>X</b> Brass - <b>CA, MB</b>	<b>Class 0 (JIS)</b>	Nil

Qualified Sub-contractor(s)	Since
XSYC	2013
-	-
-	-

**SPHERICAL ROLLER BEARINGS**  
**SERIES 240**

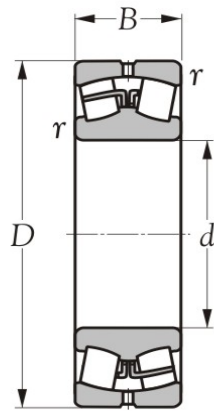

Cylindrical bore

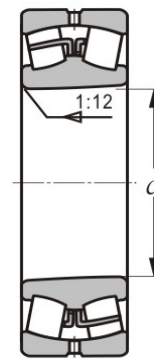

Tapered bore

Items (16)	Data  Model nos.	Dimension			Packing method	Quantity  Min. order qty.  Pcs	Delivery  Days	Unit price structure  USD	2014-09-01  Unit price structure  USD	Compare percentages (%)	Production code(s)
		Bearing sizes									
		d	D	B							
		mm									
21	24028 CA W33	140	210	69	N1	15	105	-	121.85	-	XSYC
22	24028 CA/K W33	140	210	69	N1	15	105	-	121.85	-	XSYC
23	24028 CC W33	140	210	69	N1	15	105	-	125.25	-	XSYC
24	24028 CC/K W33	140	210	69	N1	15	105	-	128.63	-	XSYC
25	24030 MB W33	150	225	75	N1	13	105	-	162.48	-	XSYC
26	24030 MB/K W33	150	225	75	N1	13	105	-	162.48	-	XSYC
27	24030 CA W33	150	225	75	N1	13	105	-	162.48	-	XSYC
28	24030 CA/K W33	150	225	75	N1	13	105	-	162.48	-	XSYC
29	24030 CC W33	150	225	75	N1	13	105	-	165.85	-	XSYC
30	24030 CC/K W33	150	225	75	N1	13	105	-	169.24	-	XSYC
31	24032 MB W33	160	240	80	N1	10	105	-	192.93	-	XSYC
32	24032 MB/K W33	160	240	80	N1	10	105	-	192.93	-	XSYC
33	24032 CA W33	160	240	80	N1	10	105	-	192.93	-	XSYC
34	24032 CA/K W33	160	240	80	N1	10	105	-	192.93	-	XSYC
35	24032 CC W33	160	240	80	N1	10	105	-	196.33	-	XSYC
36	24032 CC/K W33	160	240	80	N1	10	105	-	199.70	-	XSYC

<b>Remark</b>	Technical supplement	Precision	Grease
	Cage(s)		
	Steel - CC	Class 0 (JIS)	Nil
	Polymid - X		
Brass - CA, MB			

Qualified Sub-contractor(s)	Since
XSYC	2013
-	-
-	-

**SPHERICAL ROLLER BEARINGS**  
**SERIES 241**

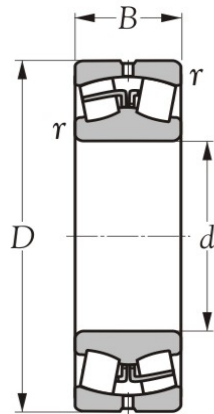

Cylindrical bore

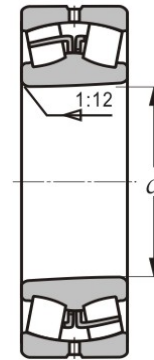

Tapered bore

Items (20)	Data  Model nos.	Dimension			Packing method	Quantity  Min. order qty.  Pcs	Delivery  Days	-	2014-09-01	Compare percentages (%)	Production code(s)		
		Bearing sizes										Unit price structure  USD	Unit price structure  USD
		d	D	B									
		mm											
1	24122 MB W33	110	180	69	N1	13	105	-	142.16	-	XSYC		
2	24122 MB/K W33	110	180	69	N1	13	105	-	142.16	-	XSYC		
3	24122 CA W33	110	180	69	N1	13	105	-	142.16	-	XSYC		
4	24122 CA/K W33	110	180	69	N1	13	105	-	142.16	-	XSYC		
5	24122 CC W33	110	180	69	N1	13	105	-	155.70	-	XSYC		
6	24122 CC/K W33	110	180	69	N1	13	105	-	159.08	-	XSYC		
7	24124 MB W33	120	200	80	N1	10	105	-	162.48	-	XSYC		
8	24124 MB/K W33	120	200	80	N1	10	105	-	162.48	-	XSYC		
9	24124 CA W33	120	200	80	N1	10	105	-	162.48	-	XSYC		
10	24124 CA/K W33	120	200	80	N1	10	105	-	162.48	-	XSYC		
11	24124 CC W33	120	200	80	N1	10	105	-	176.01	-	XSYC		
12	24124 CC/K W33	120	200	80	N1	10	105	-	179.39	-	XSYC		
13	24126 MB W33	130	210	80	N1	10	105	-	196.33	-	XSYC		
14	24126 MB/K W33	130	210	80	N1	10	105	-	196.33	-	XSYC		
15	24126 CA W33	130	210	80	N1	10	105	-	196.33	-	XSYC		
16	24126 CA/K W33	130	210	80	N1	10	105	-	196.33	-	XSYC		
17	24126 CC W33	130	210	80	N1	10	105	-	199.70	-	XSYC		
18	24126 CC/K W33	130	210	80	N1	10	105	-	203.08	-	XSYC		
19	24128 MB W33	140	225	85	N1	10	105	-	230.16	-	XSYC		
20	24128 MB/K W33	140	225	85	N1	10	105	-	230.16	-	XSYC		

Remark	Technical supplement		
	Cage(s)	Precision	Grease
	Steel - <b>CC</b> Polyimid - <b>X</b> Brass - <b>CA, MB</b>	<b>Class 0</b> (JIS)	Nil

Qualified Sub-contractor(s)	Since
XSYC	2013
-	-
-	-



**SPHERICAL ROLLER BEARINGS**  
**SERIES 241**

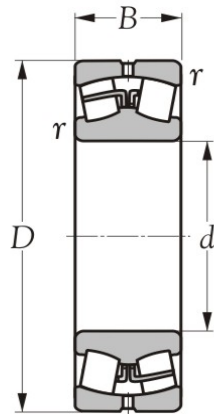

Cylindrical bore

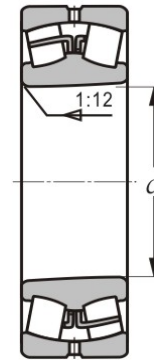

Tapered bore

Items (16)	Data  Model nos.	Dimension			Packing method	Quantity  Min. order qty.  Pcs	Delivery  Days	-	2014-09-01	Compare percentages (%)	Production code(s)		
		Bearing sizes										Unit price structure  USD	Unit price structure  USD
		d	D	B									
		mm											
21	24128 CA W33	140	225	85	N1	10	105	-	230.16	-	XSYC		
22	24128 CA/K W33	140	225	85	N1	10	105	-	230.16	-	XSYC		
23	24128 CC W33	140	225	85	N1	10	105	-	243.70	-	XSYC		
24	24128 CC/K W33	140	225	85	N1	10	105	-	247.10	-	XSYC		
25	24130 MB W33	150	250	100	N1	8	105	-	304.64	-	XSYC		
26	24130 MB/K W33	150	250	100	N1	8	105	-	304.64	-	XSYC		
27	24130 CA W33	150	250	100	N1	8	105	-	304.64	-	XSYC		
28	24130 CA/K W33	150	250	100	N1	8	105	-	304.64	-	XSYC		
29	24130 CC W33	150	250	100	N1	8	105	-	287.70	-	XSYC		
30	24130 CC/K W33	150	250	100	N1	8	105	-	294.48	-	XSYC		
31	24132 MB W33	160	270	109	N1	5	105	-	314.79	-	XSYC		
32	24132 MB/K W33	160	270	109	N1	5	105	-	314.79	-	XSYC		
33	24132 CA W33	160	270	109	N1	5	105	-	314.79	-	XSYC		
34	24132 CA/K W33	160	270	109	N1	5	105	-	314.79	-	XSYC		
35	24132 CC W33	160	270	109	N1	5	105	-	321.55	-	XSYC		
36	24132 CC/K W33	160	270	109	N1	5	105	-	331.70	-	XSYC		

Remark	Technical supplement		
	Cage(s)	Precision	Grease
	Steel - <b>CC</b> Polymid - <b>X</b> Brass - <b>CA, MB</b>	<b>Class 0 (JIS)</b>	Nil

Qualified Sub-contractor(s)	Since
XSYC	2013
-	-
-	-



# NEEDLE ROLLER BEARINGS



**CAGE AND ROLLER TYPE NEEDLE ROLLER BEARINGS**  
**SERIES K**

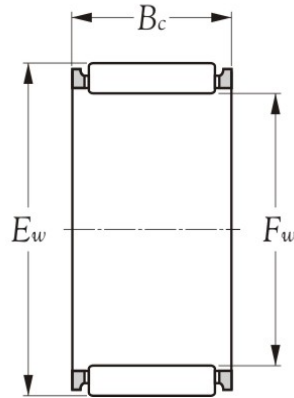

Items (20)	Data  Model nos.	Dimension			Packing method	Quantity  Min. order qty.  Pcs	Delivery  Days	Unit price structure  USD	2014-09-01  Unit price structure  USD	Compare percentages (%)	Production code(s)
		Bearing sizes									
		Fw	Ew	Bc							
		mm									
1	K 3x6x7 (10x2)	3	6	7	N2	1,000	90	-	0.45	-	YF
2	K 4x7x7 (10x2)	4	7	7	N2	1,000	90	-	0.45	-	YF
3	K 5x8x8 (10x2)	5	8	8	N2	1,000	90	-	0.45	-	YF
4	K 5x8x10 (10x2)	5	8	10	N2	1,000	90	-	0.45	-	YF
5	K 6x9x8 (10x2)	6	9	8	N2	1,000	90	-	0.45	-	YF
6	K 6x9x10 (10x1)	6	9	10	N2	1,000	90	-	0.48	-	YF
7	K 6x10x13 (5x1)	6	10	13	N2	1,000	90	-	0.61	-	YF
8	K 7x10x8 (5x1)	7	10	8	N2	1,000	90	-	0.45	-	YF
9	K 7x10x10 (5x1)	7	10	10	N2	1,000	90	-	0.48	-	YF
10	K 8x11x8 (10x2)	8	11	8	N2	1,000	90	-	0.45	-	YF
11	K 8x11x10 (10x2)	8	11	10	N2	1,000	90	-	0.45	-	YF
12	K 8x11x13 (10x2)	8	11	13	N2	550	90	-	0.51	-	YF
13	K 8x12x10 (10x2)	8	12	10	N2	550	90	-	0.48	-	YF
14	K 8x12x12 (10x2)	8	12	12	N2	550	90	-	0.48	-	YF
15	K 8x12x13 (10x2)	8	12	13	N2	550	90	-	0.48	-	YF
16	K 9x12x10 (10x2)	9	12	10	N2	550	90	-	0.48	-	YF
17	K 9x12x13 (10x2)	9	12	13	N2	550	90	-	0.48	-	YF
18	K 10x13x10 (5x1)	10	13	10	N2	550	90	-	0.48	-	YF
19	K 10x13x13 (5x1)	10	13	13	N2	550	90	-	0.48	-	YF
20	K 10x14x8 (5x1)	10	14	8	N2	550	90	-	0.48	-	YF

<b>Remark</b>	Technical supplement		
	Cage(s)	Precision	Grease
	Steel - <input checked="" type="checkbox"/>	Class 0 (JIS)	Nil
	Polymid - <input checked="" type="checkbox"/>		
Brass - <input checked="" type="checkbox"/>			

Qualified Sub-contractor(s)	Since
YF	2004
-	-
-	-

**CAGE AND ROLLER TYPE NEEDLE ROLLER BEARINGS**  
**SERIES K**

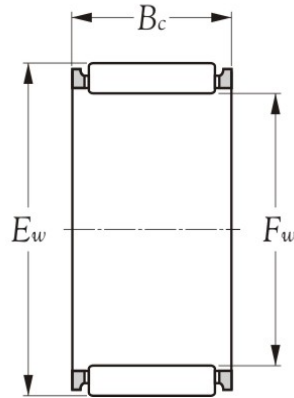

Items (20)	Data  Model nos.	Dimension			Packing method	Quantity  Min. order qty.  Pcs	Delivery  Days	Unit price structure  USD	2014-09-01  Unit price structure  USD	Compare percentages (%)	Production code(s)
		Bearing sizes									
		<i>F<sub>w</sub></i>	<i>E<sub>w</sub></i>	<i>B<sub>c</sub></i>							
		mm									
21	K 10x14x10 (5x1)	10	14	10	N2	550	90	-	0.41	-	YF
22	K 10x14x13 (5x1)	10	14	13	N2	550	90	-	0.40	-	YF
23	K 10x16x12 (5x1)	10	16	12	N2	550	90	-	0.45	-	YF
24	K 11x14x10 (5x1)	11	14	10	N2	550	90	-	0.48	-	YF
25	K 12x15x9 (5x1)	12	15	9	N2	550	90	-	0.48	-	YF
26	K 12x15x13	12	15	13	N1	450	90	-	0.48	-	YF
27	K 12x16x8 (5x1)	12	16	8	N2	550	90	-	0.48	-	YF
28	K 12x16x13 (5x1)	12	16	13	N2	450	90	-	0.48	-	YF
29	K 12x17x13 (5x1)	12	17	13	N2	450	90	-	0.45	-	YF
30	K 12x18x12 (5x1)	12	18	12	N2	400	90	-	0.48	-	YF
31	K 14x17x10 (5x1)	14	17	10	N2	450	90	-	0.48	-	YF
32	K 14x18x10 (5x1)	14	18	10	N2	450	90	-	0.48	-	YF
33	K 14x18x11 (5x1)	14	18	11	N2	450	90	-	0.48	-	YF
34	K 14x18x13 (5x1)	14	18	13	N2	450	90	-	0.48	-	YF
35	K 14x18x17	14	18	17	N1	400	90	-	0.41	-	YF
36	K 14x19x13	14	19	13	N1	400	90	-	0.53	-	YF
37	K 14x20x12	14	20	12	N1	350	90	-	0.53	-	YF
38	K 14x20x17	14	20	17	N1	300	90	-	0.56	-	YF
39	K 15x18x14 (5x1)	15	18	14	N2	400	90	-	0.51	-	YF
40	* K 15x19x17	15	19	17	N1	350	90	-	0.61	-	YF

<b>Remark</b>	Technical supplement		
	Cage(s)	Precision	Grease
	Steel - <input checked="" type="checkbox"/>	Class 0 (JIS)	Nil
	Polymid - <input checked="" type="checkbox"/>		
Brass - <input checked="" type="checkbox"/>			

Qualified Sub-contractor(s)	Since
YF	2004
-	-
-	-

CAGE AND ROLLER TYPE NEEDLE ROLLER BEARINGS

SERIES **K**

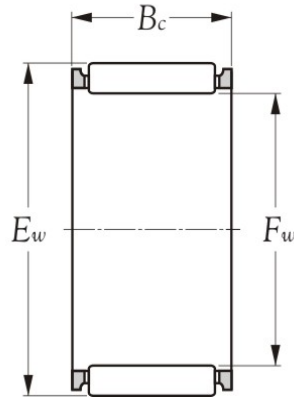

Items (20)	Data  Model nos.	Dimension			Packing method	Quantity  Min. order qty.  Pcs	Delivery  Days	Unit price structure  USD	2014-09-01  Unit price structure  USD	Compare percentages (%)	Production code(s)
		Bearing sizes									
		<i>F<sub>w</sub></i>	<i>E<sub>w</sub></i>	<i>B<sub>c</sub></i>							
		mm									
41	K 15x20x13	15	20	13	N1	300	90	-	0.56	-	YF
42	K 15x21x15	15	21	15	N1	350	90	-	0.56	-	YF
43	K 15x21x21	15	21	21	N1	300	90	-	0.61	-	YF
44	K 16x20x10	16	20	10	N1	350	90	-	0.53	-	YF
45	K 16x20x11	16	20	11	N1	350	90	-	0.53	-	YF
46	K 16x20x13	16	20	13	N1	350	90	-	0.53	-	YF
47	K 16x22x12	16	22	12	N1	300	90	-	0.61	-	YF
48	K 16x22x17	16	22	17	N1	300	90	-	0.64	-	YF
49	K 16x22x20	16	22	20	N1	300	90	-	0.68	-	YF
50	K 17x21x15	17	21	15	N1	350	90	-	0.53	-	YF
51	K 17x21x17	17	21	17	N1	350	90	-	0.56	-	YF
52	K 17x22x20	17	22	20	N1	300	90	-	0.68	-	YF
53	K 17x23x17	17	23	17	N1	250	90	-	0.68	-	YF
54	* K 18x22x10	18	22	10	N1	350	90	-	0.53	-	YF
55	K 18x22x13	18	22	13	N1	350	90	-	0.56	-	YF
56	K 18x22x17	18	22	17	N1	300	90	-	0.61	-	YF
57	K 18x24x12	18	24	12	N1	300	90	-	0.61	-	YF
58	K 18x24x13	18	24	13	N1	300	90	-	0.61	-	YF
59	K 18x24x20	18	24	20	N1	250	90	-	0.74	-	YF
60	K 18x25x17	18	25	17	N1	250	90	-	0.76	-	YF

<b>Remark</b>	Technical supplement		
	Cage(s)	Precision	Grease
	Steel - <input checked="" type="checkbox"/>	Class 0 (JIS)	Nil
	Polymid - <input checked="" type="checkbox"/>		
Brass - <input checked="" type="checkbox"/>			

Qualified Sub-contractor(s)	Since
YF	2004
-	-
-	-

CAGE AND ROLLER TYPE NEEDLE ROLLER BEARINGS

SERIES **K**

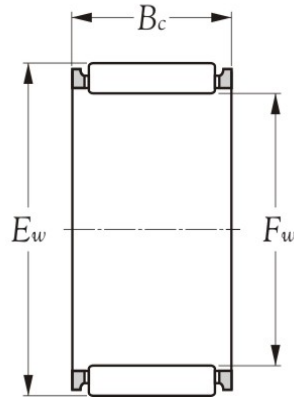

Items (20)	Data  Model nos.	Dimension			Packing method	Quantity  Min. order qty.  Pcs	Delivery  Days	-		2014-09-01  Unit price structure  USD	Compare percentages (%)	Production code(s)
		Bearing sizes						Unit price structure  USD	Unit price structure  USD			
		Fw	Ew	Bc								
		mm						USD	USD			
61	K 18x25x22	18	25	22	N1	200	90	-	0.79	-	YF	
62	K 19x23x13	19	23	13	N1	350	90	-	0.61	-	YF	
63	K 19x23x17	19	23	17	N1	300	90	-	0.64	-	YF	
64	K 20x24x11	20	24	11	N1	350	90	-	0.74	-	YF	
65	K 20x26x12	20	26	12	N1	300	90	-	0.68	-	YF	
66	K 20x28x25	20	28	25	N1	250	90	-	1.10	-	YF	
67	K 21x25x13	21	25	13	N1	300	90	-	0.68	-	YF	
68	K 21x25x17	21	25	17	N1	300	90	-	0.74	-	YF	
69	K 22x26x13	22	26	13	N1	250	90	-	0.71	-	YF	
70	K 22x27x20	22	27	20	N1	250	90	-	0.84	-	YF	
71	K 22x28x17	22	28	17	N1	250	90	-	0.84	-	YF	
72	K 22x30x15	22	30	15	N1	200	90	-	1.03	-	YF	
73	K 23x28x24	23	28	24	N1	250	90	-	0.96	-	YF	
74	K 24x28x13	24	28	13	N1	250	90	-	0.89	-	YF	
75	K 24x28x17	24	28	17	N1	250	90	-	0.93	-	YF	
76	K 24x29x13	24	29	13	N1	250	90	-	0.93	-	YF	
77	K 24x30x17	24	30	17	N1	200	90	-	0.96	-	YF	
78	K 25x29x10	25	29	10	N1	250	90	-	0.89	-	YF	
79	K 25x29x13	25	29	13	N1	250	90	-	0.91	-	YF	
80	K 25x30x13	25	30	13	N1	250	90	-	0.93	-	YF	

<b>Remark</b>	Technical supplement		
	Cage(s)	Precision	Grease
	Steel - <input checked="" type="checkbox"/>	Class 0 (JIS)	Nil
	Polymid - <input checked="" type="checkbox"/>		
Brass - <input checked="" type="checkbox"/>			

Qualified Sub-contractor(s)	Since
YF	2004
-	-
-	-

CAGE AND ROLLER TYPE NEEDLE ROLLER BEARINGS

SERIES **K**

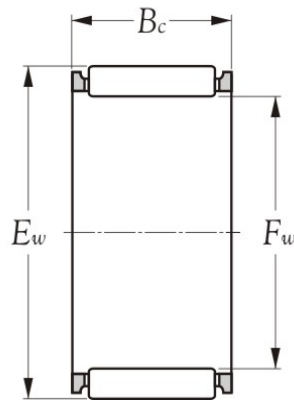

Items (20)	Data  Model nos.	Dimension			Packing method	Quantity  Min. order qty.  Pcs	Delivery  Days	Unit price structure  USD	2014-09-01  Unit price structure  USD	Compare percentages (%)	Production code(s)
		Bearing sizes									
		<i>F<sub>w</sub></i>	<i>E<sub>w</sub></i>	<i>B<sub>c</sub></i>							
		mm									
81	K 25x31x13	25	31	13	N1	250	90	-	0.96	-	YF
82	K 25x31x14	25	31	14	N1	250	90	-	0.96	-	YF
83	K 25x31x17	25	31	17	N1	250	90	-	1.03	-	YF
84	K 25x31x21	25	31	21	N1	200	90	-	1.10	-	YF
85	K 26x30x13	26	30	13	N1	250	90	-	0.96	-	YF
86	K 26x30x17	26	30	17	N1	250	90	-	0.99	-	YF
87	K 26x34x22	26	34	22	N1	250	90	-	1.13	-	YF
88	K 28x32x17	28	32	17	N1	250	90	-	1.03	-	YF
89	K 28x32x21	28	32	21	N1	250	90	-	1.05	-	YF
90	K 28x33x13	28	33	13	N1	250	90	-	1.10	-	YF
91	K 28x33x27	28	33	27	N1	200	90	-	1.13	-	YF
92	K 28x34x14	28	34	14	N1	200	90	-	1.13	-	YF
93	K 28x34x17	28	34	17	N1	200	90	-	1.19	-	YF
94	K 28x35x16	28	35	16	N1	200	90	-	1.19	-	YF
95	K 28x35x18	28	35	18	N1	200	90	-	1.24	-	YF
96	K 29x34x27	29	34	27	N1	180	90	-	1.30	-	YF
97	K 30x37x16	30	37	16	N1	160	90	-	1.19	-	YF
98	K 30x37x18	30	37	18	N1	160	90	-	1.24	-	YF
99	K 30x38x18	30	38	18	N1	150	90	-	1.30	-	YF
100	K 32x37x13	32	37	13	N1	180	90	-	1.03	-	YF

<b>Remark</b>	Technical supplement		
	Cage(s)	Precision	Grease
	Steel - <input checked="" type="checkbox"/>	Class 0 (JIS)	Nil
	Polymid - <input checked="" type="checkbox"/>		
Brass - <input checked="" type="checkbox"/>			

Qualified Sub-contractor(s)	Since
YF	2004
-	-
-	-

CAGE AND ROLLER TYPE NEEDLE ROLLER BEARINGS

SERIES **K**

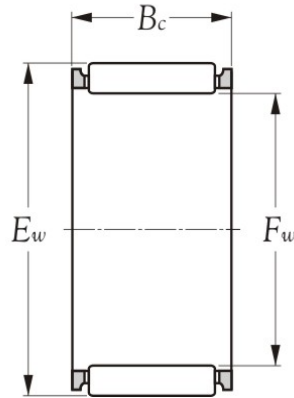

Items (20)	Data  Model nos.	Dimension			Packing method	Quantity  Min. order qty.  Pcs	Delivery  Days	-		Compare percentages (%)	Production code(s)
		Bearing sizes						Unit price structure	Unit price structure		
		<i>F<sub>w</sub></i>	<i>E<sub>w</sub></i>	<i>B<sub>c</sub></i>							
		mm					USD	USD			
101	K 32x38x26	32	38	26	N1	160	90	-	1.38	-	YF
102	K 32x39x16	32	39	16	N1	160	90	-	1.19	-	YF
103	K 32x39x18	32	39	18	N1	160	90	-	1.24	-	YF
104	K 35x40x13	35	40	13	N1	150	90	-	1.23	-	YF
105	K 35x40x17	35	40	17	N1	150	90	-	1.24	-	YF
106	K 35x41x14	35	41	14	N1	150	90	-	1.23	-	YF
107	K 35x41x15	35	41	15	N1	150	90	-	1.23	-	YF
108	K 35x42x16	35	42	16	N1	140	90	-	1.28	-	YF
109	K 35x42x18	35	42	18	N1	140	90	-	1.28	-	YF
110	K 35x42x20	35	42	20	N1	130	90	-	1.38	-	YF
111	K 35x42x30	35	42	30	N1	120	90	-	1.51	-	YF
112	K 37x42x13	37	42	13	N1	150	90	-	1.24	-	YF
113	K 37x44x18	37	44	18	N1	100	90	-	1.56	-	YF
114	K 38x43x17	38	43	17	N1	120	90	-	1.45	-	YF
115	K 38x43x27	38	43	27	N1	100	90	-	1.70	-	YF
116	K 38x46x32	38	46	32	N1	120	90	-	2.05	-	YF
117	K 40x45x13	40	45	13	N1	120	90	-	1.44	-	YF
118	K 40x45x17	40	45	17	N1	120	90	-	1.44	-	YF
119	K 40x45x21	40	45	21	N1	120	90	-	1.45	-	YF
120	K 40x45x27	40	45	27	N1	120	90	-	1.51	-	YF

<b>Remark</b>	Technical supplement		
	Cage(s)	Precision	Grease
	Steel - <input checked="" type="checkbox"/>	Class 0 (JIS)	Nil
	Polymid - <input checked="" type="checkbox"/>		
Brass - <input checked="" type="checkbox"/>			

Qualified Sub-contractor(s)	Since
YF	2004
-	-
-	-



CAGE AND ROLLER TYPE NEEDLE ROLLER BEARINGS

SERIES **K**

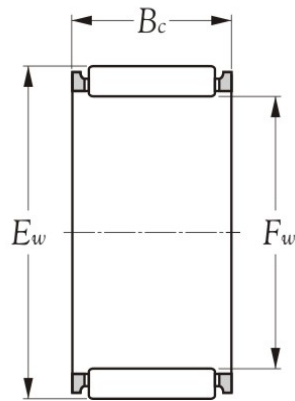

Items (20)	Data  Model nos.	Dimension			Packing method	Quantity  Min. order qty.  Pcs	Delivery  Days	Unit price structure  USD	2014-09-01  Unit price structure  USD	Compare percentages (%)	Production code(s)
		Bearing sizes									
		<i>F<sub>w</sub></i>	<i>E<sub>w</sub></i>	<i>B<sub>c</sub></i>							
		mm									
121	K 40x46x17	40	46	17	N1	120	90	-	1.44	-	YF
122	K 40x47x18	40	47	18	N1	120	90	-	1.49	-	YF
123	K 40x47x20	40	47	20	N1	120	90	-	1.51	-	YF
124	K 40x48x20	40	48	20	N1	120	90	-	1.59	-	YF
125	K 40x48x25	40	48	25	N1	120	90	-	1.70	-	YF
126	K 42x47x17	42	47	17	N1	150	90	-	1.38	-	YF
127	K 42x47x27	42	47	27	N1	120	90	-	1.51	-	YF
128	K 42x48x17	42	48	17	N1	120	90	-	1.44	-	YF
129	K 42x50x20	42	50	20	N1	120	90	-	1.70	-	YF
130	K 43x48x17	43	48	17	N1	120	90	-	1.70	-	YF
131	K 43x48x27	43	48	27	N1	120	90	-	1.70	-	YF
132	K 43x50x18	43	50	18	N1	120	90	-	1.70	-	YF
133	K 45x49x19	45	49	19	N1	120	90	-	1.51	-	YF
134	K 45x50x27	45	50	27	N1	120	90	-	1.70	-	YF
135	K 45x52x18	45	52	18	N1	120	90	-	1.70	-	YF
136	K 45x52x21	45	52	21	N1	120	90	-	1.70	-	YF
137	K 45x53x20	45	53	20	N1	120	90	-	1.86	-	YF
138	K 45x53x25	45	53	25	N1	120	90	-	1.98	-	YF
139	K 47x52x17	47	52	17	N1	120	90	-	1.64	-	YF
140	K 47x52x27	47	52	27	N1	120	90	-	1.86	-	YF

<b>Remark</b>	Technical supplement		
	Cage(s)	Precision	Grease
	Steel - <input checked="" type="checkbox"/>	Class 0 (JIS)	Nil
	Polymid - <input checked="" type="checkbox"/>		
Brass - <input checked="" type="checkbox"/>			

Qualified Sub-contractor(s)	Since
YF	2004
-	-
-	-

**CAGE AND ROLLER TYPE NEEDLE ROLLER BEARINGS**  
**SERIES K**

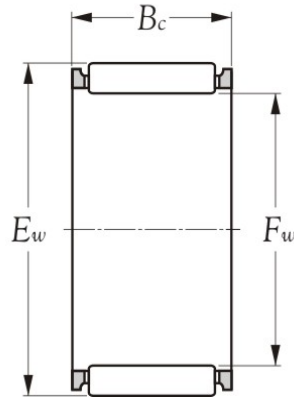

Items (20)	Data  Model nos.	Dimension			Packing method	Quantity  Min. order qty.  Pcs	Delivery  Days	Unit price structure  USD	2014-09-01  Unit price structure  USD	Compare percentages (%)	Production code(s)
		Bearing sizes									
		<i>F<sub>w</sub></i>	<i>E<sub>w</sub></i>	<i>B<sub>c</sub></i>							
		mm									
141	K 48x54x19	48	54	19	N1	100	90	-	1.80	-	YF
142	K 50x55x13.5	50	55	13.5	N1	120	90	-	1.70	-	YF
143	* K 50x55x20	50	55	20	N1	120	90	-	1.75	-	YF
144	K 50x55x27	50	55	27	N1	120	90	-	1.86	-	YF
145	K 50x55x30	50	55	30	N1	120	90	-	2.05	-	YF
146	K 50x57x18	50	57	18	N1	120	90	-	1.86	-	YF
147	K 50x58x20	50	58	20	N1	120	90	-	2.05	-	YF
148	K 50x58x25	50	58	25	N1	120	90	-	2.20	-	YF
149	K 52x58x19	52	58	19	N1	120	90	-	1.86	-	YF
150	K 55x60x17	55	60	17	N1	120	90	-	1.86	-	YF
151	K 55x60x20	55	60	20	N1	120	90	-	2.05	-	YF
152	K 55x60x30	55	60	30	N1	120	90	-	2.20	-	YF
153	K 55x61x19	55	61	19	N1	120	90	-	2.05	-	YF
154	K 55x61x20	55	61	20	N1	120	90	-	2.05	-	YF
155	K 55x61x30	55	61	30	N1	120	90	-	2.33	-	YF
156	K 55x62x18	55	62	18	N1	120	90	-	2.05	-	YF
157	K 55x63x20	55	63	20	N1	120	90	-	2.20	-	YF
158	K 55x63x25	55	63	25	N1	120	90	-	2.20	-	YF
159	K 55x63x32	55	63	32	N1	100	90	-	2.33	-	YF
160	K 58x64x19	58	64	19	N1	90	90	-	2.05	-	YF

<b>Remark</b>	Technical supplement		
	Cage(s)	Precision	Grease
	Steel - <input checked="" type="checkbox"/>	Class 0 (JIS)	Nil
	Polymid - <input checked="" type="checkbox"/>		
Brass - <input checked="" type="checkbox"/>			

Qualified Sub-contractor(s)	Since
YF	2004
-	-
-	-

**CAGE AND ROLLER TYPE NEEDLE ROLLER BEARINGS**  
**SERIES K**

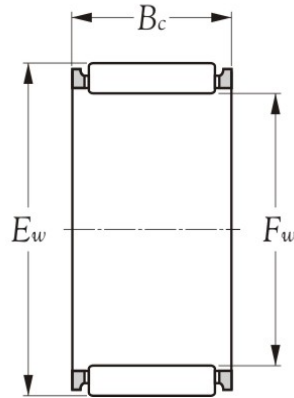

Items (20)	Data  Model nos.	Dimension			Packing method	Quantity  Min. order qty.  Pcs	Delivery  Days	Unit price structure  USD	2014-09-01  Unit price structure  USD	Compare percentages (%)	Production code(s)
		Bearing sizes									
		<i>F<sub>w</sub></i>	<i>E<sub>w</sub></i>	<i>B<sub>c</sub></i>							
		mm									
161	<b>K 60x65x20</b>	60	65	20	N1	120	90	-	<b>2.05</b>	-	YF
162	<b>K 60x65x30</b>	60	65	30	N1	90	90	-	<b>2.38</b>	-	YF
163	<b>K 60x66x19</b>	60	66	19	N1	120	90	-	<b>2.05</b>	-	YF
164	<b>K 60x66x20</b>	60	66	20	N1	120	90	-	<b>2.05</b>	-	YF
165	<b>K 60x66x30</b>	60	66	30	N1	90	90	-	<b>2.38</b>	-	YF
166	<b>K 60x68x15</b>	60	68	15	N1	100	90	-	<b>2.20</b>	-	YF
167	<b>K 60x68x20</b>	60	68	20	N1	90	90	-	<b>2.38</b>	-	YF
168	<b>K 60x68x23</b>	60	68	23	N1	90	90	-	<b>2.38</b>	-	YF
169	<b>K 60x68x25</b>	60	68	25	N1	90	90	-	<b>2.56</b>	-	YF
170	<b>K 60x68x27</b>	60	68	27	N1	80	90	-	<b>2.56</b>	-	YF
171	<b>K 61x66x20</b>	61	66	20	N1	100	90	-	<b>2.05</b>	-	YF
172	<b>K 61x66x30</b>	61	66	30	N1	90	90	-	<b>2.38</b>	-	YF
173	<b>K 63x70x21</b>	63	70	21	N1	90	90	-	<b>2.20</b>	-	YF
174	<b>K 64x70x16</b>	64	70	16	N1	90	90	-	<b>2.20</b>	-	YF
175	<b>K 65x70x20</b>	65	70	20	N1	90	90	-	<b>2.20</b>	-	YF
176	<b>K 65x70x30</b>	65	70	30	N1	90	90	-	<b>2.56</b>	-	YF
177	<b>K 65x73x23</b>	65	73	23	N1	90	90	-	<b>2.56</b>	-	YF
178	<b>K 65x73x30</b>	65	73	30	N1	80	90	-	<b>2.36</b>	-	YF
179	<b>K 68x74x20</b>	68	74	20	N1	90	90	-	<b>2.56</b>	-	YF
180	<b>K 68x74x30</b>	68	74	30	N1	80	90	-	<b>3.25</b>	-	YF

<b>Remark</b>	Technical supplement		
	Cage(s)	Precision	Grease
	Steel - <input checked="" type="checkbox"/>	Class 0 (JIS)	Nil
	Polymid - <input checked="" type="checkbox"/>		
Brass - <input checked="" type="checkbox"/>			

Qualified Sub-contractor(s)	Since
YF	2004
-	-
-	-

**CAGE AND ROLLER TYPE NEEDLE ROLLER BEARINGS**  
**SERIES K**

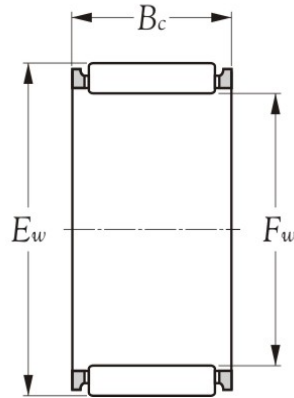

Items (20)	Data  Model nos.	Dimension			Packing method	Quantity  Min. order qty.  Pcs	Delivery  Days	Unit price structure  USD	2014-09-01  Unit price structure  USD	Compare percentages (%)	Production code(s)
		Bearing sizes									
		<i>F<sub>w</sub></i>	<i>E<sub>w</sub></i>	<i>B<sub>c</sub></i>							
		mm									
181	K 68x75x21	68	75	21	N1	80	90	-	2.70	-	YF
182	K 70x76x20	70	76	20	N1	80	90	-	2.70	-	YF
183	K 70x76x30	70	76	30	N1	80	90	-	3.40	-	YF
184	K 70x77x21	70	77	21	N1	80	90	-	2.70	-	YF
185	K 70x78x23	70	78	23	N1	70	90	-	2.89	-	YF
186	K 70x78x30	70	78	30	N1	60	90	-	3.58	-	YF
187	K 72x79x21	72	79	21	N1	70	90	-	2.89	-	YF
188	K 73x79x30	73	79	30	N1	60	90	-	3.76	-	YF
189	K 75x81x30	75	81	30	N1	70	90	-	3.78	-	YF
190	K 75x82x21	75	82	21	N1	70	90	-	2.84	-	YF
191	K 75x83x23	75	83	23	N1	70	90	-	3.15	-	YF
192	K 75x83x30	75	83	30	N1	70	90	-	4.08	-	YF
193	K 80x86x20	80	86	20	N1	70	90	-	3.15	-	YF
194	K 80x86x30	80	86	30	N1	60	90	-	3.78	-	YF
195	K 80x88x23	80	88	23	N1	60	90	-	4.08	-	YF
196	K 80x88x26	80	88	26	N1	60	90	-	4.24	-	YF
197	K 80x88x30	80	88	30	N1	60	90	-	4.39	-	YF
198	K 85x92x30	85	92	30	N1	50	90	-	4.39	-	YF
199	K 85x93x27	85	93	27	N1	50	90	-	4.39	-	YF
200	K 85x93x30	85	93	30	N1	50	90	-	4.74	-	YF

<b>Remark</b>	Technical supplement		
	Cage(s)	Precision	Grease
	Steel - <input checked="" type="checkbox"/>	Class 0 (JIS)	Nil
	Polymid - <input checked="" type="checkbox"/>		
Brass - <input checked="" type="checkbox"/>			

Qualified Sub-contractor(s)	Since
YF	2004
-	-
-	-

**CAGE AND ROLLER TYPE NEEDLE ROLLER BEARINGS**  
**SERIES K**

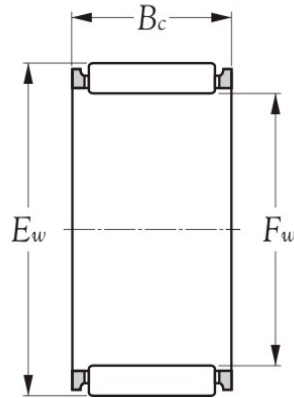

Items (20)	Data  Model nos.	Dimension			Packing method	Quantity  Min. order qty.  Pcs	Delivery  Days	Unit price structure  USD	2014-09-01  Unit price structure  USD	Compare percentages (%)	Production code(s)
		Bearing sizes									
		Fw	Ew	Bc							
		mm									
201	K 90x97x20	90	97	20	N1	50	90	-	4.39	-	YF
202	K 90x97x30	90	97	30	N1	40	90	-	5.33	-	YF
203	K 90x98x26	90	98	26	N1	40	90	-	4.74	-	YF
204	K 90x98x27	90	98	27	N1	40	90	-	4.74	-	YF
205	K 90x98x30	90	98	30	N1	40	90	-	5.04	-	YF
206	K 95x102x21	95	102	21	N1	30	90	-	5.33	-	YF
207	K 95x102x31	95	102	31	N1	30	90	-	6.28	-	YF
208	K 95x103x27	95	103	27	N1	30	90	-	7.23	-	YF
209	K 95x103x30	95	103	30	N1	20	90	-	7.85	-	YF
210	K 100x107x21	100	107	21	N1	20	90	-	7.85	-	YF
211	K 100x107x31	100	107	31	N1	20	90	-	9.43	-	YF
212	K 100x108x27	100	108	27	N1	20	90	-	8.80	-	YF
213	K 100x108x30	100	108	30	N1	20	90	-	9.74	-	YF
214	K 105x112x21	105	112	21	N1	20	90	-	8.16	-	YF
215	K 105x112x31	105	112	31	N1	20	90	-	10.05	-	YF
216	K 105x113x30	105	113	30	N1	20	90	-	10.36	-	YF
217	K 110x117x24	110	117	24	N1	-	-	-	-	-	-
218	K 110x117x34	110	117	34	N1	-	-	-	-	-	-
219	* K 110x118x30	110	118	30	N1	-	-	-	-	-	-
220	K 115x123x27	115	123	27	N1	-	-	-	-	-	-

<b>Remark</b>	Technical supplement		
	Cage(s)	Precision	Grease
	Steel - <input checked="" type="checkbox"/>	Class 0 (JIS)	Nil
	Polymid - <input checked="" type="checkbox"/>		
Brass - <input checked="" type="checkbox"/>			

Qualified Sub-contractor(s)	Since
YF	2004
-	-
-	-

**CAGE AND ROLLER TYPE NEEDLE ROLLER BEARINGS**  
**SERIES K**

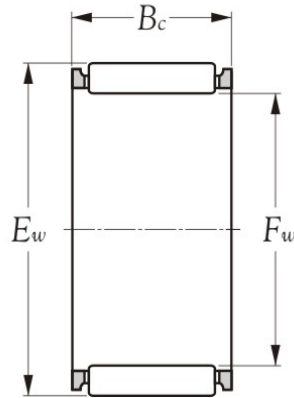

Items (20)	Data  Model nos.	Dimension			Packing method	Quantity  Min. order qty.  Pcs	Delivery  Days	-		2014-09-01  Unit price structure  USD	Compare percentages (%)	Production code(s)
		Bearing sizes						Unit price structure  USD	Unit price structure  USD			
		F <sub>w</sub>	E <sub>w</sub>	B <sub>c</sub>								
		mm						USD	USD			
221	K 115x125x34	115	125	34	N1	-	-	-	-	-	-	-
222	K 120x127x24	120	127	24	N1	-	-	-	-	-	-	-
223	K 120x127x34	120	127	34	N1	-	-	-	-	-	-	-
224	K 125x133x35	125	133	35	N1	-	-	-	-	-	-	-
225	K 125x135x34	125	135	34	N1	-	-	-	-	-	-	-
226	K 130x137x24	130	137	24	N1	-	-	-	-	-	-	-
227	K 130x137x34	130	137	34	N1	-	-	-	-	-	-	-
228	K 135x143x35	135	143	35	N1	-	-	-	-	-	-	-
229	K 135x150x38	135	150	38	N1	-	-	-	-	-	-	-
230	K 145x153x26	145	153	26	N1	-	-	-	-	-	-	-
231	K 145x153x28	145	153	28	N1	-	-	-	-	-	-	-
232	K 145x153x36	145	153	36	N1	-	-	-	-	-	-	-
233	K 150x160x46	150	160	46	N1	-	-	-	-	-	-	-
234	K 155x163x26	158	163	26	N1	-	-	-	-	-	-	-
235	K 155x163x36	155	163	36	N1	-	-	-	-	-	-	-
236	K 160x170x46	160	170	46	N1	-	-	-	-	-	-	-
237	K 165x173x26	165	173	26	N1	-	-	-	-	-	-	-
238	K 165x173x32	165	173	32	N1	-	-	-	-	-	-	-
239	K 165x173x36	165	173	36	N1	-	-	-	-	-	-	-
240	K 170x180x46	170	183	46	N1	-	-	-	-	-	-	-

<b>Remark</b>	Technical supplement		
	Cage(s)	Precision	Grease
	Steel - <input checked="" type="checkbox"/>	Class 0 (JIS)	Nil
	Polymid - <input checked="" type="checkbox"/>		
Brass - <input checked="" type="checkbox"/>			

Qualified Sub-contractor(s)	Since
YF	2004
-	-
-	-

**CAGE AND ROLLER TYPE NEEDLE ROLLER BEARINGS**  
**SERIES K**

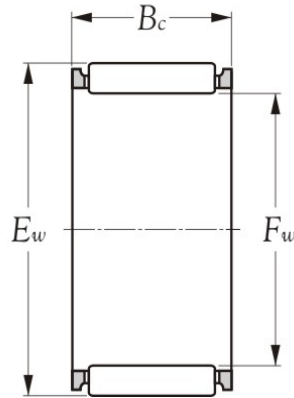

Items (8)	Data  Model nos.	Dimension			Packing method	Quantity  Min. order qty.  Pcs	Delivery  Days	-		2014-09-01  Unit price structure  USD	Compare percentages (%)	Production code(s)
		Bearing sizes						Unit price structure  USD	Unit price structure  USD			
		<i>F<sub>w</sub></i>	<i>E<sub>w</sub></i>	<i>B<sub>c</sub></i>								
		mm										
241	<b>K 175x183x32</b>	175	183	32	N1	-	-	-	-	-	-	-
242	<b>K 185x195x37</b>	185	195	37	N1	-	-	-	-	-	-	-
243	* <b>K 195x205x37</b>	195	205	37	N1	-	-	-	-	-	-	-
244	<b>K 210x220x42</b>	210	220	42	N1	-	-	-	-	-	-	-
245	<b>K 220x230x42</b>	220	230	42	N1	-	-	-	-	-	-	-
246	<b>K 240x250x42</b>	240	250	42	N1	-	-	-	-	-	-	-
247	<b>K 265x280x50</b>	265	280	50	N1	-	-	-	-	-	-	-
248	<b>K 285x300x50</b>	285	300	50	N1	-	-	-	-	-	-	-

<b>Remark</b>	Technical supplement		
	Cage(s)	Precision	Grease
	Steel - <input checked="" type="checkbox"/>	Class 0 (JIS)	Nil
	Polymid - <input checked="" type="checkbox"/>		
Brass - <input checked="" type="checkbox"/>			

Qualified Sub-contractor(s)	Since
YF	2004
-	-
-	-

**DRAWN CUP NEEDLE ROLLER BEARINGS**  
**SERIES HK.., BK..**

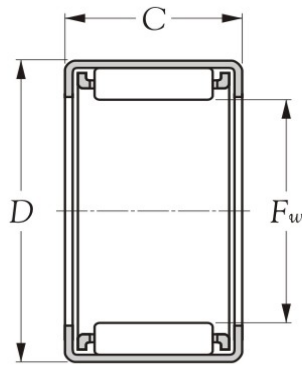

Type HK

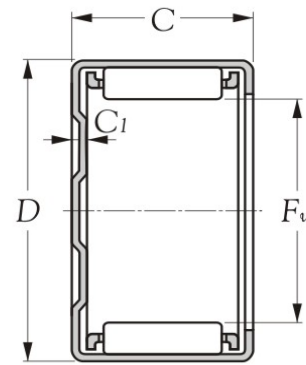

Type BK

Items (20)	Data  Model nos.	Dimension			Packing method	Quantity  Min. order qty.  Pcs	Delivery  Days	-	2014-09-01	Compare percentages (%)	Production code(s)		
		Bearing sizes										Unit price structure  USD	Unit price structure  USD
		F <sub>w</sub>	D	C									
		mm											
1	HK 0306 (10x2)	3	6.5	6	N2	1,000	90	-	0.23	-	YF		
2	* HK 0408 (10x2)	4	8	8	N2	1,000	90	-	0.21	-	YF		
3	* HK 0509 (10x2)	5	9	9	N2	1,000	90	-	0.21	-	YF		
4	* HK 0609 (5x1)	6	10	9	N2	1,000	90	-	0.20	-	YF		
5	* HK 0709 (10x2)	7	11	9	N2	1,000	90	-	0.20	-	YF		
6	* HK 0810 (10x2)	8	12	10	N2	1,000	90	-	0.20	-	YF		
7	* HK 0910 (5x1)	9	13	10	N2	1,000	90	-	0.20	-	YF		
8	HK 0912 (5x1)	9	13	12	N2	1,000	90	-	0.21	-	YF		
9	* HK 1010 (5x1)	10	14	10	N2	1,000	90	-	0.20	-	YF		
10	* HK 1012 (5x1)	10	14	12	N2	1,000	90	-	0.21	-	YF		
11	* HK 1015 (5x1)	10	14	15	N2	900	90	-	0.23	-	YF		
12	* HK 1210 (5x1)	12	16	10	N2	800	90	-	0.21	-	YF		
13	* HK 1212 (5x1)	12	18	12	N2	800	90	-	0.23	-	YF		
14	* HK 1312	13	19	12	N1	600	90	-	0.26	-	YF		
15	* HK 1412	14	20	12	N1	500	90	-	0.30	-	YF		
16	* HK 1416	14	20	16	N1	500	90	-	0.35	-	YF		
17	* HK 1512	15	21	12	N1	500	90	-	0.36	-	YF		
18	* HK 1516	15	21	16	N1	500	90	-	0.36	-	YF		
19	* HK 1612	16	22	12	N1	500	90	-	0.40	-	YF		
20	* HK 1616	16	22	16	N1	500	90	-	0.36	-	YF		

Remark	Technical supplement		
	Cage(s)	Precision	Grease
	Steel - <input checked="" type="checkbox"/>	Class 0 (JIS)	Nil
	Polymid - <input checked="" type="checkbox"/>		
	Brass - <input checked="" type="checkbox"/>		

Qualified Sub-contractor(s)	Since
YF	2004
-	-
-	-



**DRAWN CUP NEEDLE ROLLER BEARINGS**  
**SERIES HK.., BK..**

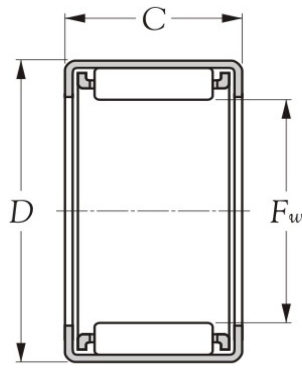

Type HK

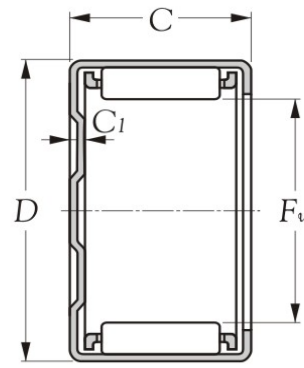

Type BK

Items (20)	Data  Model nos.	Dimension			Packing method	Quantity  Min. order qty.  Pcs	Delivery  Days	-		Compare percentages (%)	Production code(s)
		Bearing sizes						Unit price structure	Unit price structure		
		Fw	D	C							
mm			USD	USD							
21	* HK 1712	17	23	12	N1	500	90	-	0.36	-	YF
22	* HK 1812	18	24	12	N1	500	90	-	0.40	-	YF
23	* HK 1816	18	24	16	N1	400	90	-	0.41	-	YF
24	* HK 2012	20	26	12	N1	400	90	-	0.48	-	YF
25	* HK 2016	20	26	16	N1	400	90	-	0.56	-	YF
26	* HK 2020	20	26	20	N1	400	90	-	0.68	-	YF
27	* HK 2212	22	28	12	N1	400	90	-	0.48	-	YF
28	* HK 2216	22	28	16	N1	400	90	-	0.48	-	YF
29	* HK 2220	22	28	20	N1	300	90	-	0.53	-	YF
30	* HK 2512	25	32	12	N1	300	90	-	0.68	-	YF
31	* HK 2516	25	32	16	N1	300	90	-	0.68	-	YF
32	* HK 2520	25	32	20	N1	300	90	-	0.68	-	YF
33	* HK 2526	25	32	26	N1	300	90	-	0.74	-	YF
34	* HK 2816	28	35	16	N1	300	90	-	0.66	-	YF
35	* HK 2820	28	35	20	N1	250	90	-	0.71	-	YF
36	HK 3012	30	37	12	N1	200	90	-	0.76	-	YF
37	* HK 3016	30	37	16	N1	250	90	-	0.88	-	YF
38	* HK 3020	30	37	20	N1	200	90	-	1.05	-	YF
39	* HK 3026	30	37	26	N1	200	90	-	0.96	-	YF
40	* HK 3512	35	42	12	N1	200	90	-	1.10	-	YF

Remark	Technical supplement		
	Cage(s)	Precision	Grease
	Steel - <input checked="" type="checkbox"/>	Class 0 (JIS)	Nil
	Polymid - <input checked="" type="checkbox"/>		
	Brass - <input checked="" type="checkbox"/>		

Qualified Sub-contractor(s)	Since
YF	2004
-	-
-	-

**DRAWN CUP NEEDLE ROLLER BEARINGS**  
**SERIES HK.., BK..**

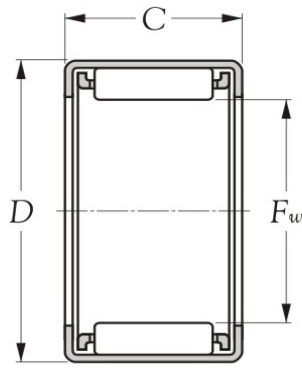

Type HK

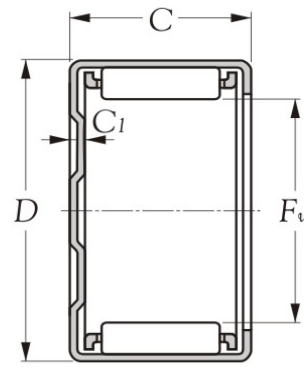

Type BK

Items (20)	Data  Model nos.	Dimension			Packing method	Quantity  Min. order qty.  Pcs	Delivery  Days	-		Compare percentages (%)	Production code(s)
		Bearing sizes						Unit price structure	Unit price structure		
		<i>F<sub>w</sub></i>	<i>D</i>	<i>C</i>							
mm			USD	USD							
41	* HK 3516	35	42	16	N1	200	90	-	1.19	-	YF
42	* HK 3520	35	42	20	N1	200	90	-	1.34	-	YF
43	* HK 4012	40	47	12	N1	200	90	-	1.14	-	YF
44	* HK 4016	40	47	16	N1	200	90	-	1.30	-	YF
45	* HK 4020	40	47	20	N1	200	90	-	1.44	-	YF
46	* HK 4516	45	52	16	N1	150	90	-	1.30	-	YF
47	* HK 4520	45	52	20	N1	150	90	-	1.45	-	YF
48	* HK 5020	50	58	20	N1	120	90	-	1.86	-	YF
49	* HK 5025	50	58	25	N1	120	90	-	2.05	-	YF
50	BK 0306 (10x2)	3	6.5	6	N2	1,000	90	-	0.23	-	YF
51	BK 0408 (10x2)	4	8	8	N2	1,000	90	-	0.21	-	YF
52	BK 0509 (10x1)	5	9	9	N2	1,000	90	-	0.21	-	YF
53	BK 0609 (5x1)	6	10	9	N2	1,000	90	-	0.20	-	YF
54	BK 0709 (10x2)	7	11	9	N2	1,000	90	-	0.20	-	YF
55	BK 0810 (10x2)	8	12	10	N2	1,000	90	-	0.19	-	YF
56	BK 0910 (5x1)	9	13	10	N2	1,000	90	-	0.20	-	YF
57	BK 0912 (5x1)	9	13	12	N2	1,000	90	-	0.21	-	YF
58	BK 1010 (5x1)	10	14	10	N2	1,000	90	-	0.19	-	YF
59	BK 1012 (5x1)	10	14	12	N2	1,000	90	-	0.21	-	YF
60	BK 1015 (5x1)	10	14	15	N2	900	90	-	0.25	-	YF

Remark	Technical supplement		
	Cage(s)	Precision	Grease
	Steel - <input checked="" type="checkbox"/>	Class 0 (JIS)	Nil
	Polymid - <input checked="" type="checkbox"/>		
	Brass - <input checked="" type="checkbox"/>		

Qualified Sub-contractor(s)	Since
YF	2004
-	-
-	-

**DRAWN CUP NEEDLE ROLLER BEARINGS**  
**SERIES HK.., BK..**

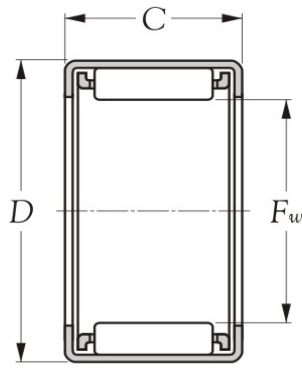

Type HK

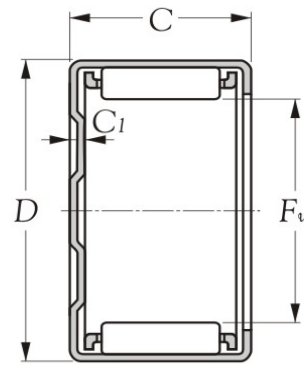

Type BK

Items (20)	Data  Model nos.	Dimension			Packing method	Quantity  Min. order qty.  Pcs	Delivery  Days	-		Compare percentages (%)	Production code(s)
		Bearing sizes						Unit price structure	2014-09-01 Unit price structure		
		F <sub>w</sub>	D	C							
		mm									
61	BK 1210 (5x1)	12	16	10	N2	800	90	-	0.21	-	YF
62	BK 1212 (5x1)	12	18	12	N2	800	90	-	0.23	-	YF
63	BK 1312	13	19	12	N1	600	90	-	0.26	-	YF
64	BK 1412	14	20	12	N1	500	90	-	0.31	-	YF
65	BK 1416	14	20	16	N1	500	90	-	0.35	-	YF
66	BK 1512	15	21	12	N1	500	90	-	0.36	-	YF
67	BK 1516	15	21	16	N1	500	90	-	0.36	-	YF
68	BK 1612	16	22	12	N1	500	90	-	0.36	-	YF
69	BK 1616	16	22	16	N1	500	90	-	0.36	-	YF
70	BK 1712	17	23	12	N1	500	90	-	0.40	-	YF
71	BK 1812	18	24	12	N1	500	90	-	0.40	-	YF
72	BK 1816	18	24	16	N1	400	90	-	0.40	-	YF
73	BK 2012	20	58	26	N1	400	90	-	0.40	-	YF
74	BK 2016	20	6.5	26	N1	400	90	-	0.48	-	YF
75	BK 2020	20	8	26	N1	400	90	-	0.51	-	YF
76	BK 2212	22	9	28	N1	400	90	-	0.48	-	YF
77	BK 2216	22	10	28	N1	400	90	-	0.48	-	YF
78	BK 2220	22	11	28	N1	300	90	-	0.53	-	YF
79	BK 2512	25	12	32	N1	300	90	-	0.53	-	YF
80	* BK 2516	25	13	32	N1	300	90	-	0.66	-	YF

Remark	Technical supplement		
	Cage(s)	Precision	Grease
	Steel - <input checked="" type="checkbox"/>	Class 0 (JIS)	Nil
	Polymid - <input checked="" type="checkbox"/>		
	Brass - <input checked="" type="checkbox"/>		

Qualified Sub-contractor(s)	Since
YF	2004
-	-
-	-

**DRAWN CUP NEEDLE ROLLER BEARINGS**  
**SERIES HK.., BK..**

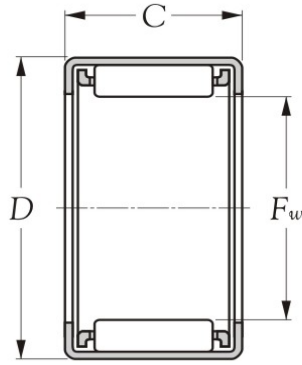

Type HK

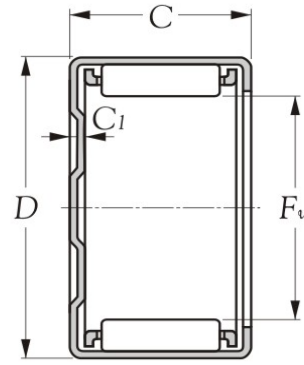

Type BK

Items (18)	Data  Model nos.	Dimension			Packing method	Quantity  Min. order qty.  Pcs	Delivery  Days	-		Compare percentages (%)	Production code(s)
		Bearing sizes						Unit price structure  USD	2014-09-01 Unit price structure  USD		
		Fw	D	C							
		mm									
81	BK 2520	25	13	32	N1	300	90	-	0.66	-	YF
82	BK 2526	25	14	32	N1	250	90	-	0.74	-	YF
83	BK 2816	28	14	35	N1	250	90	-	0.66	-	YF
84	BK 2820	28	14	35	N1	250	90	-	0.68	-	YF
85	BK 3012	30	16	37	N1	200	90	-	0.76	-	YF
86	BK 3016	30	18	37	N1	250	90	-	0.78	-	YF
87	BK 3020	30	19	37	N1	250	90	-	0.89	-	YF
88	BK 3026	30	20	37	N1	250	90	-	0.96	-	YF
89	BK 3512	35	20	42	N1	200	90	-	0.84	-	YF
90	BK 3516	35	21	42	N1	200	90	-	0.96	-	YF
91	BK 3520	35	21	42	N1	200	90	-	1.03	-	YF
92	BK 4012	40	22	47	N1	150	90	-	1.10	-	YF
93	BK 4016	40	22	47	N1	150	90	-	1.23	-	YF
94	BK 4020	40	23	47	N1	150	90	-	1.30	-	YF
95	BK 4516	45	24	52	N1	130	90	-	1.30	-	YF
96	BK 4520	45	24	52	N1	120	90	-	1.45	-	YF
97	BK 5020	50	58	20	N1	110	90	-	2.39	-	YF
98	BK 5025	50	58	25	N1	110	90	-	2.64	-	YF

Remark	Technical supplement									
	Cage(s)	Precision	Grease							
	<table border="1"> <tr> <td>Steel -</td> <td>✓</td> </tr> <tr> <td>Polymid -</td> <td>×</td> </tr> <tr> <td>Brass -</td> <td>×</td> </tr> </table>	Steel -	✓	Polymid -	×	Brass -	×	<table border="1"> <tr> <td>Class 0 (JIS)</td> </tr> </table>	Class 0 (JIS)	<table border="1"> <tr> <td>Nil</td> </tr> </table>
Steel -	✓									
Polymid -	×									
Brass -	×									
Class 0 (JIS)										
Nil										

Qualified Sub-contractor(s)	Since
YF	2004
-	-
-	-

DRAWN CUP NEEDLE ROLLER BEARINGS SEALED TYPE  
SERIES **HK..L, HK..LL, BK..L**

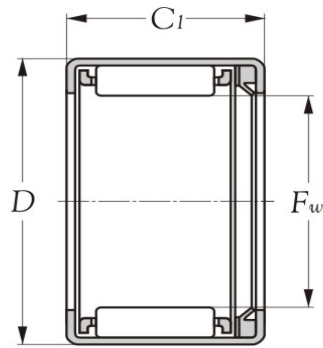

Type **HK..L**  
(Open end. single seal)

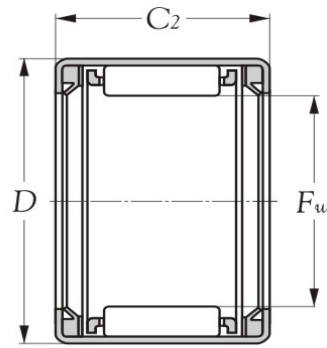

Type **HK..LL**  
(Open end. single seal)

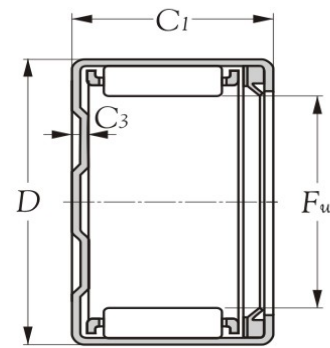

Type **BK..L**  
(Closed end. single seal)

Items (20)	Data  Model nos.	Dimension			Packing method	Quantity  Min. order qty.  Pcs	Delivery  Days	-	2014-09-01	Compare percentages (%)	Production code(s)		
		Bearing sizes										Unit price structure  USD	Unit price structure  USD
		<i>F<sub>w</sub></i>	<i>D</i>	<i>C</i>									
		mm											
1	<b>HK 1214 L (5x1)</b>	12	18	14	N2	2,000	90	-	<b>0.40</b>	-	YF		
2	<b>HK 1414 L</b>	14	20	14	N1	2,000	90	-	<b>0.40</b>	-	YF		
3	<b>HK 1514 L</b>	15	21	14	N1	2,000	90	-	<b>0.48</b>	-	YF		
4	<b>HK 1614 L</b>	16	22	14	N1	2,000	90	-	<b>0.48</b>	-	YF		
5	* <b>HK 1814 L</b>	18	24	14	N1	2,000	90	-	<b>0.48</b>	-	YF		
6	<b>HK 2018 L</b>	20	26	18	N1	2,000	90	-	<b>0.56</b>	-	YF		
7	<b>HK 2218 L</b>	22	28	18	N1	2,000	90	-	<b>0.66</b>	-	YF		
8	<b>HK 2518 L</b>	25	32	18	N1	2,000	90	-	<b>0.79</b>	-	YF		
9	<b>HK 3018 L</b>	30	37	18	N1	2,000	90	-	<b>0.94</b>	-	YF		
10	<b>HK 3518 L</b>	35	42	18	N1	2,000	90	-	<b>1.28</b>	-	YF		
11	<b>HK 4018 L</b>	40	47	18	N1	2,000	90	-	<b>1.34</b>	-	YF		
12	<b>HK 4518 L</b>	45	52	18	N1	2,000	90	-	<b>1.56</b>	-	YF		
13	<b>HK 5022 L</b>	50	58	22	N1	2,000	90	-	<b>2.20</b>	-	YF		
14	* <b>HK 1216 LL (5x1)</b>	12	18	16	N2	2,000	90	-	<b>0.41</b>	-	YF		
15	* <b>HK 1416 LL</b>	14	20	16	N1	2,000	90	-	<b>0.45</b>	-	YF		
16	* <b>HK 1516 LL</b>	15	21	16	N1	2,000	90	-	<b>0.48</b>	-	YF		
17	* <b>HK 1616 LL</b>	16	22	16	N1	2,000	90	-	<b>0.56</b>	-	YF		
18	<b>HK 1816 LL</b>	18	24	16	N1	2,000	90	-	<b>0.53</b>	-	YF		
19	<b>HK 2016 LL</b>	20	26	16	N1	2,000	90	-	<b>0.74</b>	-	YF		
20	* <b>HK 2020 LL</b>	20	26	20	N1	2,000	90	-	<b>0.74</b>	-	YF		

<b>Remark</b>	Technical supplement		
	Cage(s)	Precision	Grease
	Steel - <input checked="" type="checkbox"/>	Class 0 (JIS)	Alvania S2 -25°C~+120°C
	Polymid - <input checked="" type="checkbox"/>		
Brass - <input checked="" type="checkbox"/>			

Qualified Sub-contractor(s)	Since
YF	2004
-	-
-	-

DRAWN CUP NEEDLE ROLLER BEARINGS SEALED TYPE  
SERIES **HK..L, HK..LL, BK..L**

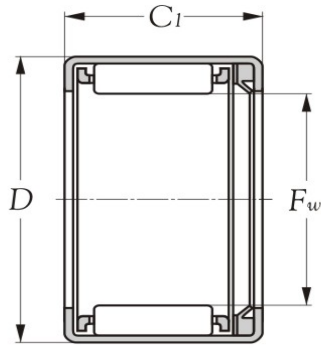

Type **HK..L**  
(Open end. single seal)

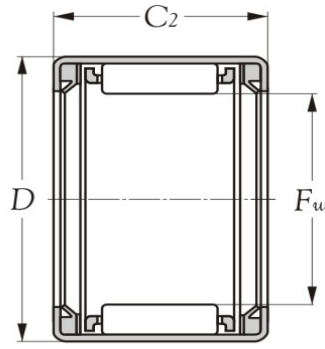

Type **HK..LL**  
(Open end. single seal)

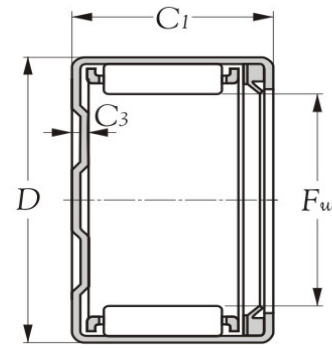

Type **BK..L**  
(Closed end. single seal)

Items (20)	Data  Model nos.	Dimension			Packing method	Quantity  Min. order qty.	Delivery  Days	-	2014-09-01	Compare percentages (%)	Production code(s)		
		Bearing sizes										Unit price structure	Unit price structure
		<i>F<sub>w</sub></i>	<i>D</i>	<i>C</i>									
		mm				Pcs							
21	HK 2216 LL	22	26	16	N1	2,000	90	-	0.74	-	YF		
22	HK 2220 LL	22	28	20	N1	2,000	90	-	0.84	-	YF		
23	* HK 2516 LL	25	32	16	N1	2,000	90	-	0.88	-	YF		
24	HK 2520 LL	25	32	20	N1	2,000	90	-	0.94	-	YF		
25	HK 2820 LL	28	35	20	N2	2,000	90	-	0.96	-	YF		
26	HK 3016 LL	30	37	16	N1	2,000	90	-	1.03	-	YF		
27	* HK 3020 LL	30	37	20	N1	2,000	90	-	1.10	-	YF		
28	HK 3516 LL	35	42	16	N1	2,000	90	-	1.28	-	YF		
29	HK 3520 LL	35	42	20	N1	2,000	90	-	1.30	-	YF		
30	HK 4016 LL	40	47	16	N1	2,000	90	-	1.44	-	YF		
31	* HK 4020 LL	40	47	20	N1	2,000	90	-	1.69	-	YF		
32	* HK 4520 LL	45	52	20	N1	2,000	90	-	1.59	-	YF		
33	HK 5024 LL	50	58	24	N1	2,000	90	-	2.38	-	YF		
34	BK 1214 L (5x1)	12	18	14	N2	2,000	90	-	0.40	-	YF		
35	BK 1414 L	14	20	14	N1	2,000	90	-	0.40	-	YF		
36	BK 1514 L	15	21	14	N1	2,000	90	-	0.48	-	YF		
37	BK 1614 L	16	22	14	N1	2,000	90	-	0.48	-	YF		
38	BK 1814 L	18	24	14	N1	2,000	90	-	0.53	-	YF		
39	BK 2018 L	20	26	18	N1	2,000	90	-	0.56	-	YF		
40	BK 2218 L	22	28	18	N1	2,000	90	-	0.66	-	YF		

<b>Remark</b>	Technical supplement		
	Cage(s)	Precision	Grease
	Steel - <input checked="" type="checkbox"/>	Class 0 (JIS)	Alvania S2 -25°C~+120°C
	Polymid - <input checked="" type="checkbox"/>		
Brass - <input checked="" type="checkbox"/>			

Qualified Sub-contractor(s)	Since
YF	2004
-	-
-	-

**DRAWN CUP NEEDLE ROLLER BEARINGS SEALED TYPE**  
**SERIES HK..L, HK..LL, BK..L**

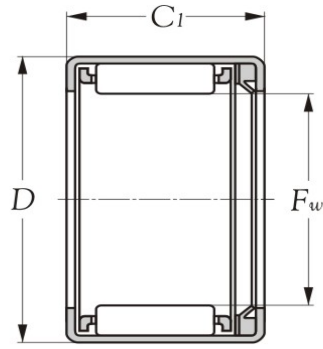

Type HK..L  
(Open end. single seal)

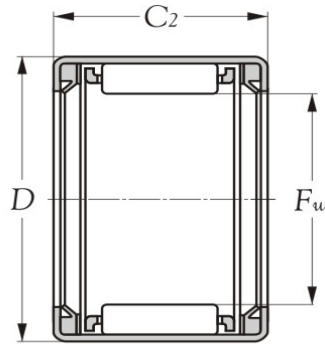

Type HK..LL  
(Open end. single seal)

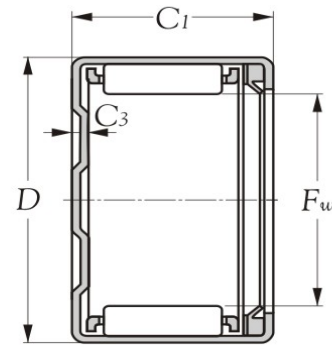

Type BK..L  
(Closed end. single seal)

Items (6)	Data  Model nos.	Dimension			Packing method	Quantity  Min. order qty.  Pcs	Delivery  Days	-		Compare percentages (%)	Production code(s)
		Bearing sizes						Unit price structure	Unit price structure		
		F <sub>w</sub>	D	C							
mm			USD	USD							
41	<b>BK 2518 L</b>	25	32	18	N1	2,000	90	-	<b>0.79</b>	-	YF
42	<b>BK 3018 L</b>	30	37	18	N1	2,000	90	-	<b>0.94</b>	-	YF
43	<b>BK 3518 L</b>	35	42	18	N1	2,000	90	-	<b>1.28</b>	-	YF
44	<b>BK 4018 L</b>	40	47	18	N1	2,000	90	-	<b>1.34</b>	-	YF
45	<b>BK 4518 L</b>	45	52	18	N1	2,000	90	-	<b>1.56</b>	-	YF
46	<b>BK 5022 L</b>	50	58	22	N1	2,000	90	-	<b>2.20</b>	-	YF

Remark : Item(s) indicate in red color(s) mean OEM business.

<b>Remark</b>	Technical supplement		Precision	Grease
	Cage(s)			
	Steel -	✓	Class 0 (JIS)	Alvania S2 -25°C~+120°C
	Polymid -	×		
Brass -	×			

Qualified Sub-contractor(s)	Since
YF	2004
-	-
-	-

MACHINED-RING NEEDLE ROLLER BEARINGS WITH INNER RING  
SERIES **NA 49-59-69**

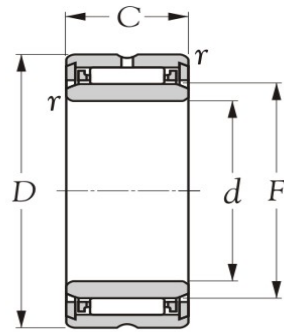

Type 49 (d ≤ 9mm)

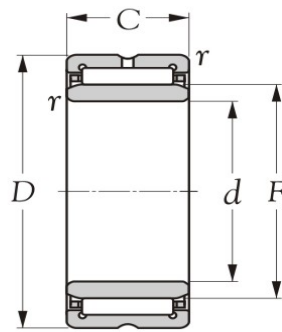

Type NA 49 (d ≥ 10mm)

Type NA 59

Type NA 69 (d ≤ 30mm)

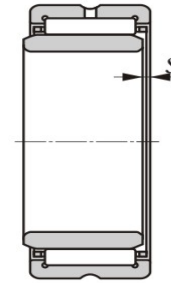

Items (20)	Data  Model nos.	Dimension			Packing method	Quantity  Min. order qty.  Pcs	Delivery  Days	-		Compare percentages (%)	Production code(s)
		Bearing sizes						Unit price structure	Unit price structure		
		d	D	C							
		mm						USD	USD		
1	NA 495 (5x1)	5	13	10	N2	130	90	-	2.38	-	YF
2	NA 496	6	15	10	N1	130	90	-	2.38	-	YF
3	NA 497 (5x1)	7	17	10	N2	130	90	-	2.05	-	YF
4	NA 498	8	19	11	N1	130	90	-	1.86	-	YF
5	NA 499	9	20	11	N1	130	90	-	1.70	-	YF
6	* NA 4900	10	22	13	N1	130	90	-	1.25	-	YF
7	* NA 4901	12	24	13	N1	130	90	-	1.33	-	YF
8	* NA 6901	12	24	22	N1	90	90	-	1.86	-	YF
9	* NA 4902	15	28	13	N1	130	90	-	1.33	-	YF
10	NA 5902	15	28	18	N1	130	90	-	2.05	-	YF
11	* NA 6902	15	28	23	N1	80	90	-	2.00	-	YF
12	* NA 4903	17	30	13	N1	110	90	-	1.70	-	YF
13	NA 5903	17	30	18	N1	110	90	-	2.20	-	YF
14	* NA 6903	17	30	23	N1	70	90	-	2.20	-	YF
15	* NA 4904	20	37	17	N1	90	90	-	1.81	-	YF
16	NA 5904	20	37	23	N1	70	90	-	2.70	-	YF
17	* NA 6904	20	37	30	N1	60	90	-	2.88	-	YF
18	NA 49/22	22	39	17	N1	70	90	-	2.38	-	YF
19	NA 59/22	22	39	23	N1	60	90	-	2.89	-	YF
20	NA 69/22	22	39	30	N1	60	90	-	3.08	-	YF

Remark	Technical supplement		
	Cage(s)	Precision	Grease
	Steel - <input checked="" type="checkbox"/>	Class 0 (JIS)	Nil
	Polymid - <input checked="" type="checkbox"/>		
	Brass - <input checked="" type="checkbox"/>		

Qualified Sub-contractor(s)	Since
YF	2004
-	-
-	-



MACHINED-RING NEEDLE ROLLER BEARINGS WITH INNER RING  
SERIES **NA 49-59-69**

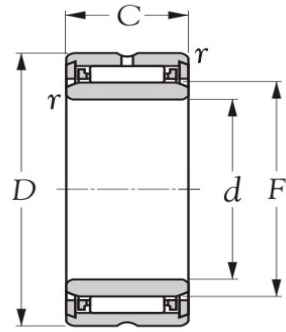

Type 49 (d ≤ 9mm)

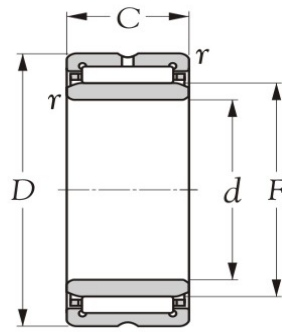

Type NA 49 (d ≥ 10mm)  
Type NA 59  
Type NA 69 (d ≤ 30mm)

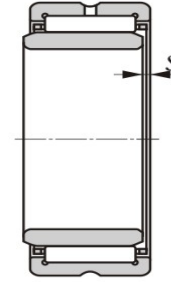

Items (20)	Data		Dimension			Packing method	Quantity Min. order qty.	Delivery	-	-	Compare percentages (%)	Production code(s)
	Model nos.	Bearing sizes	Bearing sizes									
			d	D	C							
		mm			Pcs	Days	USD	USD				
21	* NA 4905	25	42	17	N1	80	90	-	2.11	-	YF	
22	NA 5905	25	42	23	N1	60	90	-	3.25	-	YF	
23	* NA 6905	25	42	30	N1	50	90	-	3.25	-	YF	
24	NA 49/28	28	45	17	N1	60	90	-	2.70	-	YF	
25	NA 59/28	28	45	23	N1	50	90	-	3.58	-	YF	
26	NA 69/28	28	45	30	N1	40	90	-	3.76	-	YF	
27	* NA 4906	30	47	17	N1	70	90	-	2.58	-	YF	
28	NA 5906	30	47	23	N1	45	90	-	4.08	-	YF	
29	* NA 6906	30	47	30	N1	45	90	-	3.78	-	YF	
30	NA 49/32	32	52	20	N1	50	90	-	3.08	-	YF	
31	NA 59/32	32	52	27	N1	40	90	-	4.44	-	YF	
32	NA 69/32	32	52	36	N1	30	90	-	4.79	-	YF	
33	* NA 4907	35	55	20	N1	50	90	-	3.11	-	YF	
34	NA 5907	35	55	27	N1	40	90	-	5.10	-	YF	
35	* NA 6907	35	55	36	N1	35	90	-	4.60	-	YF	
36	* NA 4908	40	62	22	N1	45	90	-	3.78	-	YF	
37	NA 5908	40	62	30	N1	30	90	-	6.13	-	YF	
38	* NA 6908	40	62	40	N1	30	90	-	5.79	-	YF	
39	* NA 4909	45	68	22	N1	40	90	-	4.24	-	YF	
40	NA 5909	45	68	30	N1	30	90	-	7.49	-	YF	

Remark	Technical supplement		
	Cage(s)	Precision	Grease
	Steel - <input checked="" type="checkbox"/>	Class 0 (JIS)	Nil
	Polymid - <input checked="" type="checkbox"/>		
	Brass - <input checked="" type="checkbox"/>		

Qualified Sub-contractor(s)	Since
YF	2004
-	-
-	-

MACHINED-RING NEEDLE ROLLER BEARINGS WITH INNER RING  
 SERIES **NA 49-59-69**

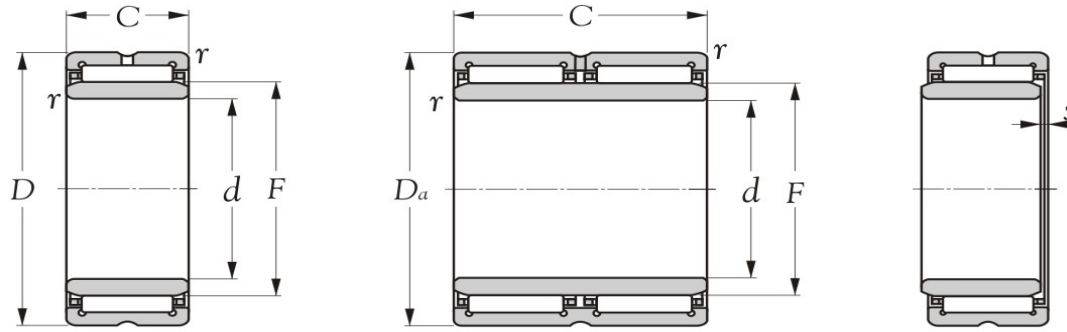

Type NA 49 (  $d \geq 10\text{mm}$  )  
 Type NA 59  
 Type NA 69 (  $d \leq 30\text{mm}$  )

Type NA 69 (  $d \geq 32\text{mm}$  )

Items (20)	Data		Dimension			Packing method	Quantity		Delivery	-	2014-09-01	Compare percentages (%)	Production code(s)		
	Model nos.	Bearing sizes	Bearing sizes				Min. order qty.	-						Unit price structure	Unit price structure
			d	D	C										
41	* NA 6909	45 68 40	45	68	40	N1	25	90	-	7.13	-	YF			
42	* NA 4910	50 72 22	50	72	22	N1	30	90	-	4.86	-	YF			
43	NA 5910	50 72 30	50	72	30	N1	20	90	-	8.51	-	YF			
44	* NA 6910	50 72 40	50	72	40	N1	20	90	-	8.14	-	YF			
45	* NA 4911	55 80 25	55	80	25	N1	30	90	-	5.50	-	YF			
46	NA 5911	55 80 34	55	80	34	N1	20	90	-	9.54	-	YF			
47	* NA 6911	55 80 45	55	80	45	N1	15	90	-	9.63	-	YF			
48	* NA 4912	60 85 25	60	85	25	N1	25	90	-	6.64	-	YF			
49	NA 5912	60 85 34	60	85	34	N1	20	90	-	10.89	-	YF			
50	* NA 6912	60 85 45	60	85	45	N1	15	90	-	11.76	-	YF			
51	* NA 4913	65 90 25	65	90	25	N1	20	90	-	7.49	-	YF			
52	NA 5913	65 90 34	65	90	34	N1	20	90	-	12.59	-	YF			
53	NA 6913	65 90 45	65	90	45	N1	10	90	-	16.49	-	YF			
54	* NA 4914	70 100 30	70	100	30	N1	20	90	-	9.96	-	YF			
55	NA 5914	70 100 40	70	100	40	N1	15	90	-	12.93	-	YF			
56	NA 6914	70 100 54	70	100	54	N1	15	90	-	19.69	-	YF			
57	NA 4915	75 105 30	75	105	30	N1	10	90	-	12.94	-	YF			
58	NA 5915	75 105 40	75	105	40	N1	10	90	-	19.04	-	YF			
59	NA 6915	75 105 54	75	105	54	N1	5	90	-	26.08	-	YF			
60	NA 4916	80 110 30	80	110	30	N1	10	90	-	16.45	-	YF			

<b>Remark</b>	Technical supplement		
	Cage(s)	Precision	Grease
	Steel - <input checked="" type="checkbox"/>	Class 0 (JIS)	Nil
	Polymid - <input checked="" type="checkbox"/>		
Brass - <input checked="" type="checkbox"/>			

Qualified Sub-contractor(s)	Since
YF	2004
-	-
-	-

MACHINED-RING NEEDLE ROLLER BEARINGS WITH INNER RING  
 SERIES **NA 49-59-69**

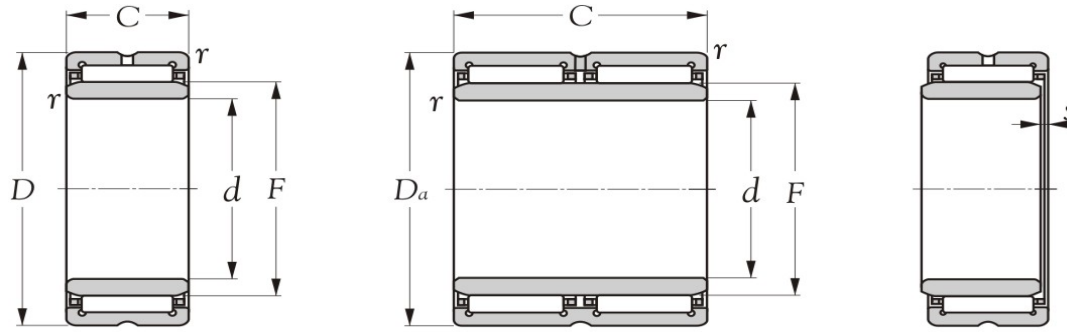

Type NA 49 (  $d \geq 10\text{mm}$  )  
 Type NA 59  
 Type NA 69 (  $d \leq 30\text{mm}$  )

Type NA 69 (  $d \geq 32\text{mm}$  )

Items (20)	Data  Model nos.	Dimension			Packing method	Quantity  Min. order qty.  Pcs	Delivery  Days	-		Compare percentages (%)	Production code(s)
		Bearing sizes						Unit price structure	2014-09-01 Unit price structure		
		d	D	C							
		mm									
61	NA 5916	80	110	40	N1	10	90	-	22.11	-	YF
62	NA 6916	80	110	54	N1	10	90	-	23.83	-	YF
63	NA 4917	85	120	35	N1	10	90	-	21.30	-	YF
64	NA 5917	85	120	46	N1	10	90	-	30.63	-	YF
65	NA 6917	85	120	63	N1	5	90	-	33.33	-	YF
66	NA 4918	90	125	35	N1	10	90	-	30.03	-	YF
67	NA 5918	90	125	46	N1	5	90	-	41.21	-	YF
68	NA 6918	90	125	63	N1	5	90	-	43.16	-	YF
69	NA 4919	95	130	35	N1	5	90	-	35.51	-	YF
70	NA 5919	95	130	46	N1	5	90	-	47.11	-	YF
71	NA 6919	95	130	63	N1	5	90	-	49.08	-	YF
72	NA 4920	100	140	40	N1	5	90	-	39.64	-	YF
73	NA 5920	100	140	54	N1	5	90	-	62.81	-	YF
74	NA 4822	110	140	30	N1	5	90	-	46.96	-	YF
75	NA 4922	110	150	40	N1	5	90	-	47.11	-	YF
76	NA 5922	110	150	54	N1	-	-	-	-	-	YF
77	NA 4824	120	150	30	N1	5	90	-	43.16	-	YF
78	NA 4924	120	165	45	N1	5	90	-	56.91	-	YF
79	NA 5924	120	165	60	N1	-	-	-	-	-	YF
80	NA 4826	130	165	35	N1	5	90	-	54.96	-	YF

<b>Remark</b>	Technical supplement		
	Cage(s)	Precision	Grease
	Steel - <input checked="" type="checkbox"/>	Class 0 (JIS)	Nil
	Polymid - <input checked="" type="checkbox"/>		
Brass - <input checked="" type="checkbox"/>			

Qualified Sub-contractor(s)	Since
YF	2004
-	-
-	-

MACHINED-RING NEEDLE ROLLER BEARINGS WITH INNER RING  
SERIES **NA 48-49-59**



Items (20)	Data  Model nos.	Dimension			Packing method	Quantity  Min. order qty.  Pcs	Delivery  Days	-	2014-09-01	Compare percentages (%)	Production code(s)		
		Bearing sizes										Unit price structure  USD	Unit price structure  USD
		d	D	C									
		mm											
81	NA 4926	130	180	50	N1	5	90	-	74.60	-	YF		
82	NA 5926	130	180	67	N1	-	-	-	-	-	-		
83	NA 4828	140	175	35	N1	5	90	-	62.81	-	YF		
84	NA 4928	140	190	50	N1	5	90	-	86.38	-	YF		
85	NA 5928	140	190	67	N1	-	-	-	-	-	-		
86	NA 4830	150	190	40	N1	5	90	-	86.38	-	YF		
87	NA 4930	150	210	60	N1	5	90	-	129.53	-	YF		
88	NA 4832	160	200	40	N1	5	90	-	102.05	-	YF		
89	NA 4932	160	220	60	N1	5	90	-	145.24	-	YF		
90	NA 4834	170	215	45	N1	5	90	-	125.60	-	YF		
91	NA 4934	170	230	60	N1	5	90	-	164.86	-	YF		
92	NA 4836	180	225	45	N1	5	90	-	145.24	-	YF		
93	NA 4936	180	250	69	N1	-	-	-	-	-	-		
94	NA 4838	190	240	50	N1	5	90	-	172.70	-	YF		
95	NA 4938	190	260	69	N1	-	-	-	-	-	-		
96	NA 4840	200	250	50	N1	5	90	-	188.41	-	YF		
97	NA 4940	200	280	80	N1	-	-	-	-	-	-		
98	NA 4844	220	270	50	N1	5	90	-	219.83	-	YF		
99	NA 4944	220	300	80	N1	-	-	-	-	-	-		
100	NA 4848	240	300	60	N1	-	-	-	-	-	-		

Remark	Technical supplement		
	Cage(s)	Precision	Grease
	Steel - <input checked="" type="checkbox"/> Polymid - <input checked="" type="checkbox"/> Brass - <input checked="" type="checkbox"/>	Class 0 (JIS)	Nil

Qualified Sub-contractor(s)	Since
YF	2004
-	-
-	-

MACHINED-RING NEEDLE ROLLER BEARINGS WITH INNER RING  
SERIES **NA 48-49**

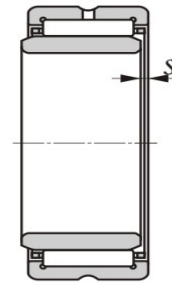
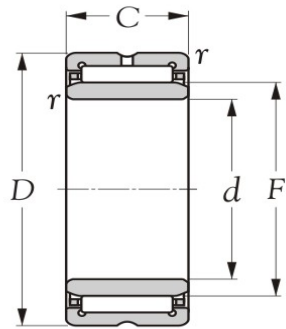

Type NA 48  
Type NA 49..R (d ≥ 10mm)  
Type NA 59

Items (18)	Data  Model nos.	Dimension			Packing method	Quantity  Min. order qty.  Pcs	Delivery  Days	-	2014-09-01	Compare percentages (%)	Production code(s)		
		Bearing sizes										Unit price structure  USD	Unit price structure  USD
		d	D	C									
		mm											
101	NA 4948	240	320	80	N1	-	-	-	-	-	-		
102	NA 4852	260	320	60	N1	-	-	-	-	-	-		
103	NA 4952	260	360	100	N1	-	-	-	-	-	-		
104	NA 4856	280	350	69	N1	-	-	-	-	-	-		
105	NA 4956	280	380	100	N1	-	-	-	-	-	-		
106	NA 4860	300	380	80	N1	-	-	-	-	-	-		
107	NA 4960	300	420	118	N1	-	-	-	-	-	-		
108	NA 4864	320	400	80	N1	-	-	-	-	-	-		
109	NA 4964	320	440	118	N1	-	-	-	-	-	-		
110	NA 4868	340	420	80	N1	-	-	-	-	-	-		
111	NA 4968	340	460	118	N1	-	-	-	-	-	-		
112	NA 4872	360	440	80	N1	-	-	-	-	-	-		
113	NA 4972	360	480	118	N1	-	-	-	-	-	-		
114	NA 4876	380	480	100	N1	-	-	-	-	-	-		
115	NA 4976	380	520	140	N1	-	-	-	-	-	-		
116	NA 4980	400	540	140	N1	-	-	-	-	-	-		
117	NA 4984	420	560	140	N1	-	-	-	-	-	-		
118	NA 4988	440	600	160	N1	-	-	-	-	-	-		

<b>Remark</b>	Technical supplement		
	Cage(s)	Precision	Grease
	Steel - <input checked="" type="checkbox"/>	Class 0 (JIS)	Nil
	Polymid - <input checked="" type="checkbox"/>		
Brass - <input checked="" type="checkbox"/>			

Qualified Sub-contractor(s)	Since
-	-
-	-
-	-

MACHINED-RING NEEDLE ROLLER BEARINGS WITH INNER RING SEALED TYPE  
SERIES **NA 49..L, LL**

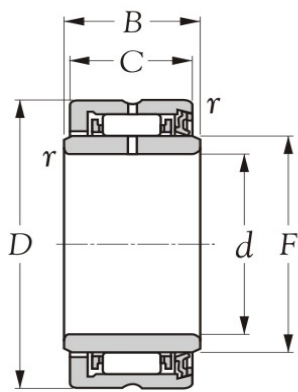

Type NA 49..L  
(With single seal)

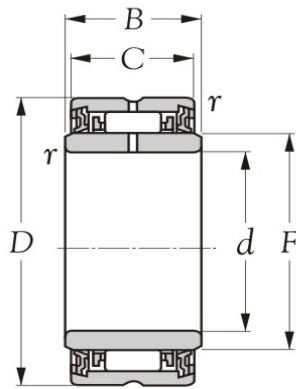

Type NA 49..LL  
(With double seal)

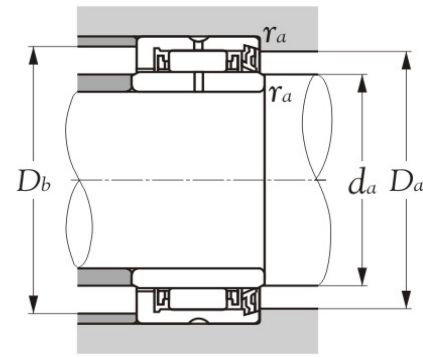

Items (22)	Data  Model nos.	Dimension			Packing method	Quantity  Min. order qty.  Pcs	Delivery  Days	-	2014-09-01	Compare percentages (%)	Production code(s)		
		Bearing sizes										Unit price structure  USD	Unit price structure  USD
		d	D	B									
		mm											
1	NA 4900 L	10	22	14	N1	110	90	-	1.66	-	YF		
2	NA 4901 L	12	24	14	N1	110	90	-	1.66	-	YF		
3	NA 4902 L	15	28	14	N1	100	90	-	1.74	-	YF		
4	NA 4903 L	17	30	14	N1	80	90	-	2.10	-	YF		
5	NA 4904 L	20	37	18	N1	70	90	-	2.39	-	YF		
6	NA 4905 L	25	42	18	N1	60	90	-	2.70	-	YF		
7	NA 4906 L	30	47	18	N1	50	90	-	3.20	-	YF		
8	NA 4907 L	35	55	21	N1	40	90	-	4.18	-	YF		
9	NA 4908 L	40	62	23	N1	35	90	-	4.95	-	YF		
10	NA 4909 L	45	68	23	N1	30	90	-	5.61	-	YF		
11	NA 4910 L	50	72	23	N1	25	90	-	6.41	-	YF		
12	* NA 4900 LL	10	22	14	N1	100	90	-	1.70	-	YF		
13	* NA 4901 LL	12	24	14	N1	100	90	-	1.61	-	YF		
14	* NA 4902 LL	15	28	14	N1	100	90	-	1.74	-	YF		
15	* NA 4903 LL	17	30	14	N1	80	90	-	2.11	-	YF		
16	* NA 4904 LL	20	37	18	N1	70	90	-	2.34	-	YF		
17	* NA 4905 LL	25	42	18	N1	60	90	-	2.66	-	YF		
18	* NA 4906 LL	30	47	18	N1	50	90	-	3.15	-	YF		
19	* NA 4907 LL	35	55	21	N1	40	90	-	4.21	-	YF		
20	* NA 4908 LL	40	62	23	N1	35	90	-	4.81	-	YF		
21	* NA 4909 LL	45	68	23	N1	30	90	-	5.76	-	YF		
22	* NA 4910 LL	50	72	23	N1	25	90	-	6.64	-	YF		

Remark	Technical supplement		
	Cage(s)	Precision	Grease
	Steel - <input checked="" type="checkbox"/> Polymid - <input checked="" type="checkbox"/> Brass - <input checked="" type="checkbox"/>	Class 0 (JIS)	Alvania S2 -25°C~+120°C

Qualified Sub-contractor(s)	Since
YF	2004
-	-
-	-

MACHINED-RING NEEDLE ROLLER BEARINGS WITHOUT INNER RING SEALED TYPE  
SERIES **RNA 49..L, LL**

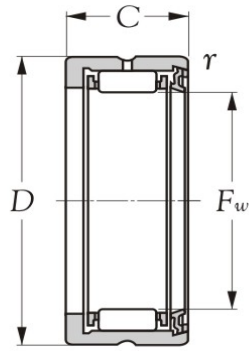

Type RNA 49..L  
( With single seal )

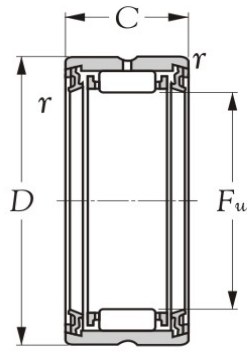

Type RNA 49..LL  
( With double seal )

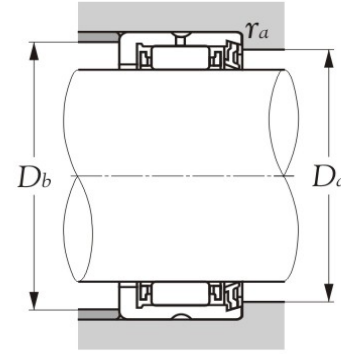

Items (22)	Data  Model nos.	Dimension			Packing method	Quantity  Min. order qty.  Pcs	Delivery  Days	-	2014-09-01	Compare percentages (%)	Production code(s)		
		Bearing sizes										Unit price structure  USD	Unit price structure  USD
		F <sub>w</sub>	D	C									
		mm											
1	RNA 4900 L	14	22	13	N1	150	90	-	1.23	-	YF		
2	RNA 4901 L	16	24	13	N1	140	90	-	1.28	-	YF		
3	RNA 4902 L	20	28	13	N1	130	90	-	1.38	-	YF		
4	RNA 4903 L	22	30	13	N1	110	90	-	1.56	-	YF		
5	RNA 4904 L	25	37	17	N1	100	90	-	1.74	-	YF		
6	RNA 4905 L	30	42	17	N1	80	90	-	2.11	-	YF		
7	RNA 4906 L	35	47	17	N1	70	90	-	2.64	-	YF		
8	RNA 4907 L	42	55	20	N1	50	90	-	3.40	-	YF		
9	RNA 4908 L	48	62	22	N1	40	90	-	3.99	-	YF		
10	RNA 4909 L	52	68	22	N1	35	90	-	4.59	-	YF		
11	RNA 4910 L	58	72	22	N1	30	90	-	5.36	-	YF		
12	RNA 4900 LL	14	22	13	N1	140	90	-	1.30	-	YF		
13	RNA 4901 LL	16	24	13	N1	130	90	-	1.34	-	YF		
14	* RNA 4902 LL	20	28	13	N1	120	90	-	1.44	-	YF		
15	RNA 4903 LL	22	30	13	N1	110	90	-	1.59	-	YF		
16	RNA 4904 LL	25	37	17	N1	90	90	-	1.86	-	YF		
17	RNA 4905 LL	30	42	17	N1	80	90	-	2.20	-	YF		
18	RNA 4906 LL	35	47	17	N1	60	90	-	2.70	-	YF		
19	RNA 4907 LL	42	55	20	N1	50	90	-	3.76	-	YF		
20	* RNA 4908 LL	48	62	22	N1	40	90	-	4.18	-	YF		
21	RNA 4909 LL	52	68	22	N1	35	90	-	4.79	-	YF		
22	RNA 4910 LL	58	72	22	N1	30	90	-	5.53	-	YF		

Remark	Technical supplement		
	Cage(s)	Precision	Grease
	Steel - <input checked="" type="checkbox"/>	Class 0 (JIS)	Alvania S2 -25°C~+120°C
	Polymid - <input checked="" type="checkbox"/>		
	Brass - <input checked="" type="checkbox"/>		

Qualified Sub-contractor(s)	Since
YF	2004
-	-
-	-

MACHINED-RING NEEDLE ROLLER BEARINGS WITHOUT INNER RING

SERIES **RNA 49-59-69**

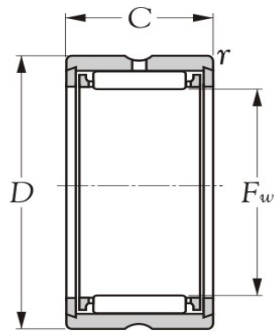

Type RNA 49 (  $F_w \leq 12\text{mm}$  )

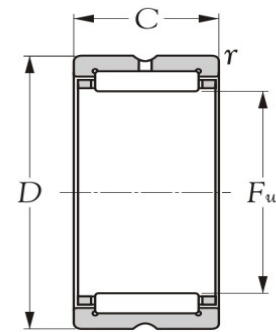

Type RNA 49 (  $F_w \geq 14\text{mm}$  )  
Type RNA 59  
Type RNA 69 (  $F_w \leq 35\text{mm}$  )

Items (20)	Data  Model nos.	Dimension			Packing method	Quantity  Min. order qty.  Pcs	Delivery  Days	-	2014-09-01	Compare percentages (%)	Production code(s)		
		Bearing sizes										Unit price structure  USD	Unit price structure  USD
		$F_w$	$D$	$C$									
		mm											
1	RNA 495 (5x1)	7	13	10	N2	100	90	-	1.84	-	YF		
2	RNA 496	8	15	10	N1	100	90	-	1.84	-	YF		
3	RNA 497 (5x1)	9	17	10	N2	100	90	-	1.65	-	YF		
4	RNA 498	10	19	11	N1	120	90	-	1.45	-	YF		
5	RNA 499	12	20	11	N1	150	90	-	1.28	-	YF		
6	* RNA 4900	14	22	13	N1	170	90	-	1.03	-	YF		
7	* RNA 4901	16	24	13	N1	150	90	-	1.14	-	YF		
8	RNA 6901	16	24	22	N1	110	90	-	1.59	-	YF		
9	RNA 4902	20	28	13	N1	140	90	-	1.28	-	YF		
10	RNA 5902	20	28	18	N1	140	90	-	1.56	-	YF		
11	RNA 6902	20	28	23	N1	100	90	-	1.74	-	YF		
12	RNA 4903	22	30	13	N1	120	90	-	1.44	-	YF		
13	RNA 5903	22	30	18	N1	100	90	-	1.75	-	YF		
14	RNA 6903	22	30	23	N1	90	90	-	1.96	-	YF		
15	RNA 4904	25	37	17	N1	110	90	-	1.66	-	YF		
16	RNA 5904	25	37	23	N1	90	90	-	2.03	-	YF		
17	RNA 6904	25	37	30	N1	80	90	-	2.20	-	YF		
18	RNA 49/22	28	39	17	N1	90	90	-	1.96	-	YF		
19	RNA 59/22	28	39	23	N1	90	90	-	2.36	-	YF		
20	RNA 69/22	28	39	30	N1	60	90	-	2.85	-	YF		

Remark	Technical supplement		
	Cage(s)	Precision	Grease
	Steel - <input checked="" type="checkbox"/> Polymid - <input checked="" type="checkbox"/> Brass - <input checked="" type="checkbox"/>	Class 0 (JIS)	Nil

Qualified Sub-contractor(s)	Since
YF	2004
-	-
-	-



MACHINED-RING NEEDLE ROLLER BEARINGS WITHOUT INNER RING  
SERIES **RNA 49-59-69**

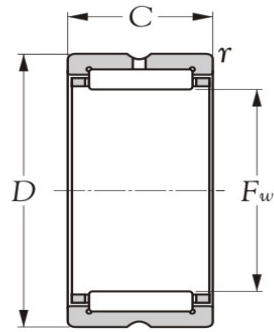

Type RNA 49 ( $F_w \geq 14\text{mm}$ )  
Type RNA 59  
Type RNA 69 ( $F_w \leq 35\text{mm}$ )

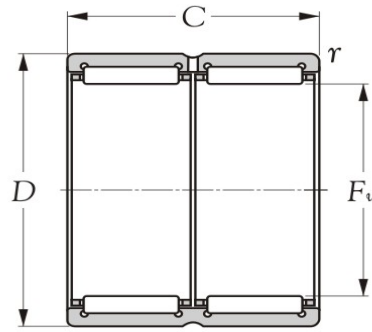

Type RNA 69 ( $F_w \geq 40\text{mm}$ )

Items (20)	Data  Model nos.	Dimension			Packing method	Quantity  Min. order qty.  Pcs	Delivery  Days	-		Compare percentages (%)	Production code(s)
		Bearing sizes						Unit price structure	2014-09-01 Unit price structure		
		$F_w$	$D$	$C$				USD	USD		
21	RNA 4905	30	42	17	N1	90	90	-	1.93	-	YF
22	RNA 5905	30	42	23	N1	90	90	-	2.44	-	YF
23	* RNA 6905	30	42	30	N1	60	90	-	2.95	-	YF
24	RNA 49/28	32	45	17	N1	70	90	-	2.36	-	YF
25	RNA 59/28	32	45	23	N1	70	90	-	2.95	-	YF
26	RNA 69/28	32	45	30	N1	45	90	-	3.81	-	YF
27	RNA 4906	35	47	17	N1	80	90	-	2.29	-	YF
28	RNA 5906	35	47	23	N1	80	90	-	2.99	-	YF
29	RNA 6906	35	47	30	N1	50	90	-	3.41	-	YF
30	RNA 49/32	35	47	30	N1	50	90	-	2.68	-	YF
31	RNA 59/32	40	52	20	N1	80	90	-	3.41	-	YF
32	RNA 69/32	40	52	27	N1	80	90	-	3.81	-	YF
33	RNA 4907	42	55	20	N1	60	90	-	2.85	-	YF
34	RNA 5907	42	55	27	N1	50	90	-	3.39	-	YF
35	RNA 6907	42	55	36	N1	40	90	-	4.24	-	YF
36	* RNA 4908	48	62	22	N1	50	90	-	3.49	-	YF
37	RNA 5908	48	62	30	N1	50	90	-	4.16	-	YF
38	RNA 6908	48	62	40	N1	30	90	-	5.53	-	YF
39	RNA 4909	52	68	22	N1	45	90	-	4.08	-	YF
40	RNA 5909	52	68	30	N1	40	90	-	5.10	-	YF

Remark	Technical supplement		
	Cage(s)	Precision	Grease
	Steel - <input checked="" type="checkbox"/>	Class 0 (JIS)	Nil
	Polymid - <input checked="" type="checkbox"/>		
	Brass - <input checked="" type="checkbox"/>		

Qualified Sub-contractor(s)	Since
YF	2004
-	-
-	-

MACHINED-RING NEEDLE ROLLER BEARINGS WITHOUT INNER RING  
 SERIES **RNA 48-49-59-69**

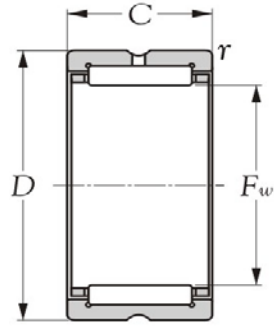

Type RNA 48  
 Type RNA 49 (Fw ≥ 14mm)  
 Type RNA 59

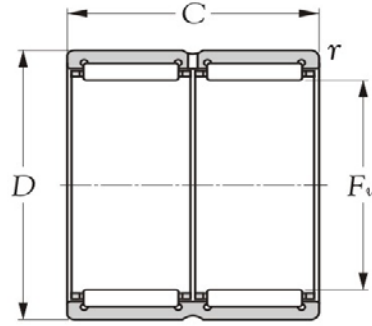

Type RNA 69 (Fw ≥ 40mm)

Items (20)	Data  Model nos.	Dimension			Packing method	Quantity  Min. order qty.  Pcs	Delivery  Days	-		Compare percentages (%)	Production code(s)
		Bearing sizes						Unit price structure	Unit price structure		
		Fw	D	C							
mm			USD	USD							
41	RNA 6909	52	68	40	N1	25	90	-	6.93	-	YF
42	RNA 4910	58	72	22	N1	35	90	-	4.86	-	YF
43	RNA 5910	58	72	30	N1	35	90	-	6.28	-	YF
44	RNA 6910	58	72	40	N1	20	90	-	7.94	-	YF
45	RNA 4911	63	80	25	N1	30	90	-	5.76	-	YF
46	RNA 5911	63	80	34	N1	25	90	-	7.18	-	YF
47	RNA 6911	63	80	45	N1	20	90	-	9.74	-	YF
48	RNA 4912	68	85	25	N1	25	90	-	6.66	-	YF
49	RNA 5912	68	85	34	N1	25	90	-	8.56	-	YF
50	RNA 6912	68	85	45	N1	15	90	-	11.45	-	YF
51	RNA 4913	72	90	25	N1	20	90	-	8.03	-	YF
52	RNA 5913	72	90	34	N1	20	90	-	9.84	-	YF
53	RNA 6913	72	90	45	N1	10	90	-	13.65	-	YF
54	RNA 4914	80	100	30	N1	20	90	-	9.54	-	YF
55	RNA 5914	80	100	40	N1	20	90	-	9.81	-	YF
56	RNA 6914	80	100	54	N1	10	90	-	16.49	-	YF
57	RNA 4915	85	105	30	N1	15	90	-	11.41	-	YF
58	RNA 5915	85	105	40	N1	15	90	-	14.54	-	YF
59	RNA 6915	85	105	54	N1	10	90	-	19.06	-	YF
60	RNA 4916	90	110	30	N1	10	90	-	14.58	-	YF

<b>Remark</b>	Technical supplement		
	Cage(s)	Precision	Grease
	Steel - <input checked="" type="checkbox"/>	Class 0 (JIS)	Nil
	Polymid - <input checked="" type="checkbox"/>		
Brass - <input checked="" type="checkbox"/>			

Qualified Sub-contractor(s)	Since
YF	2004
-	-
-	-

MACHINED-RING NEEDLE ROLLER BEARINGS WITHOUT INNER RING  
 SERIES **RNA48-49-59**

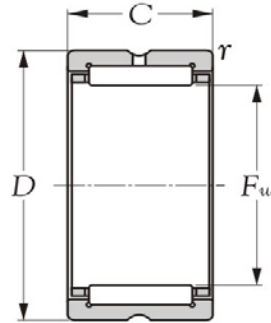

Type RNA 48  
 Type RNA 49 ( $F_w \geq 14\text{mm}$ )  
 Type RNA 59

Items (20)	Data  Model nos.	Dimension			Packing method	Quantity  Min. order qty.  Pcs	Delivery  Days	-	2014-09-01	Compare percentages (%)	Production code(s)		
		Bearing sizes										Unit price structure  USD	Unit price structure  USD
		$F_w$	$D$	$C$									
		mm											
61	RNA 5916	90	110	40	N1	10	90	-	18.78	-	YF		
62	RNA 6916	90	110	54	N1	10	90	-	21.30	-	YF		
63	RNA 4917	100	120	35	N1	10	90	-	17.46	-	YF		
64	RNA 5917	100	120	46	N1	10	90	-	24.06	-	YF		
65	RNA 6917	100	120	63	N1	5	90	-	26.08	-	YF		
66	RNA 4918	105	125	35	N1	10	90	-	21.76	-	YF		
67	RNA 5918	105	125	46	N1	10	90	-	27.70	-	YF		
68	RNA 6918	105	125	63	N1	10	90	-	29.65	-	YF		
69	RNA 4919	110	130	35	N1	10	90	-	25.69	-	YF		
70	RNA 5919	110	130	46	N1	10	90	-	31.63	-	YF		
71	RNA 6919	110	130	63	N1	10	90	-	33.60	-	YF		
72	RNA 4920	115	140	40	N1	10	90	-	31.63	-	YF		
73	RNA 5920	115	140	54	N1	10	90	-	47.44	-	YF		
74	RNA 4822	120	140	30	N1	10	90	-	31.63	-	YF		
75	RNA 4922	125	150	40	N1	10	90	-	35.59	-	YF		
76	RNA 5922	125	150	54	N1	-	-	-	-	-	-		
77	RNA 4824	130	150	30	N1	5	90	-	30.63	-	YF		
78	RNA 4924	135	165	45	N1	10	90	-	41.51	-	YF		
79	RNA 5924	135	165	60	N1	-	-	-	-	-	-		
80	RNA 4826	145	165	35	N1	10	90	-	39.54	-	YF		

<b>Remark</b>	Technical supplement		
	Cage(s)	Precision	Grease
	Steel - <input checked="" type="checkbox"/>	Class 0 (JIS)	Nil
	Polymid - <input checked="" type="checkbox"/>		
Brass - <input checked="" type="checkbox"/>			

Qualified Sub-contractor(s)	Since
YF	2004
-	-
-	-

MACHINED-RING NEEDLE ROLLER BEARINGS WITHOUT INNER RING  
SERIES **RNA48-49**

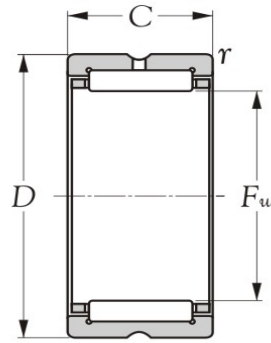

Type RNA 48  
Type RNA 49 (Fw ≥ 14mm)

Items (20)	Data  Model nos.	Dimension			Packing method	Quantity  Min. order qty.  Pcs	Delivery  Days	-	2014-09-01	Compare percentages (%)	Production code(s)		
		Bearing sizes										Unit price structure  USD	Unit price structure  USD
		Fw	D	C									
		mm											
81	RNA 4926	150	180	50	N1	5	90	-	55.34	-	YF		
82	RNA 5926	150	180	67	N1	-	-	-	-	-	-		
83	RNA 4828	155	175	35	N1	5	90	-	49.41	-	YF		
84	RNA 4928	160	190	50	N1	5	90	-	63.26	-	YF		
85	RNA 5928	160	190	67	N1	-	-	-	-	-	-		
86	RNA 4830	165	190	40	N1	5	90	-	67.24	-	YF		
87	RNA 4930	170	210	60	N1	-	90	-	94.93	-	YF		
88	RNA 4832	175	200	40	N1	5	90	-	68.03	-	YF		
89	RNA 4932	180	220	60	N1	5	90	-	106.78	-	YF		
90	RNA 4834	185	215	45	N1	5	90	-	98.89	-	YF		
91	RNA 4934	190	230	60	N1	5	90	-	118.65	-	YF		
92	RNA 4836	195	225	45	N1	5	90	-	112.71	-	YF		
93	RNA 4936	205	250	69	N1	-	-	-	-	-	-		
94	RNA 4838	210	240	50	N1	5	90	-	134.48	-	YF		
95	RNA 4938	215	260	69	N1	-	-	-	-	-	-		
96	RNA 4840	220	250	50	N1	5	90	-	146.33	-	YF		
97	RNA 4940	225	280	80	N1	-	-	-	-	-	-		
98	RNA 4844	240	270	50	N1	5	90	-	166.13	-	YF		
99	RNA 4944	245	300	80	N1	-	-	-	-	-	-		
100	RNA 4848	265	300	60	N1	-	-	-	-	-	-		

Remark	Technical supplement		
	Cage(s)	Precision	Grease
	Steel - <input checked="" type="checkbox"/> Polymid - <input checked="" type="checkbox"/> Brass - <input checked="" type="checkbox"/>	Class 0 (JIS)	Nil

Qualified Sub-contractor(s)	Since
YF	2004
-	-
-	-

MACHINED-RING NEEDLE ROLLER BEARINGS WITHOUT INNER RING  
SERIES **RNA48-49**

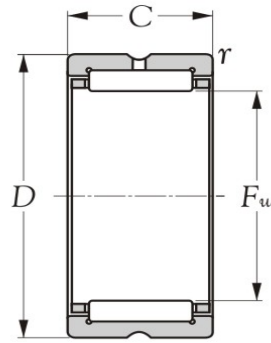

Type RNA 48  
Type RNA 49 (Fw ≥ 14mm)

Items (18)	Data  Model nos.	Dimension			Packing method	Quantity  Min. order qty.  Pcs	Delivery  Days	-	2014-09-01	Compare percentages (%)	Production code(s)		
		Bearing sizes										Unit price structure  USD	Unit price structure  USD
		Fw	D	C									
		mm											
101	RNA 4948	265	320	80	N1	-	-	-	-	-	-		
102	RNA 4852	285	320	60	N1	-	-	-	-	-	-		
103	RNA 4952	290	360	100	N1	-	-	-	-	-	-		
104	RNA 4856	305	350	69	N1	-	-	-	-	-	-		
105	RNA 4956	310	380	100	N1	-	-	-	-	-	-		
106	RNA 4860	330	380	80	N1	-	-	-	-	-	-		
107	RNA 4960	340	420	118	N1	-	-	-	-	-	-		
108	RNA 4864	350	400	80	N1	-	-	-	-	-	-		
109	RNA 4964	360	440	118	N1	-	-	-	-	-	-		
110	RNA 4868	370	420	80	N1	-	-	-	-	-	-		
111	RNA 4968	380	460	118	N1	-	-	-	-	-	-		
112	RNA 4872	390	440	80	N1	-	-	-	-	-	-		
113	RNA 4972	400	480	118	N1	-	-	-	-	-	-		
114	RNA 4876	415	480	100	N1	-	-	-	-	-	-		
115	RNA 4976	430	520	140	N1	-	-	-	-	-	-		
116	RNA 4980	450	540	140	N1	-	-	-	-	-	-		
117	RNA 4984	470	560	140	N1	-	-	-	-	-	-		
118	RNA 4988	490	600	160	N1	-	-	-	-	-	-		

<b>Remark</b>	Technical supplement	Precision	Grease
	Cage(s)		
	Steel - ✓	Class 0 (JIS)	Nil
	Polymid - ✗		
Brass - ✗			

Qualified Sub-contractor(s)	Since
-	-
-	-
-	-

**MACHINED-RING NEEDLE ROLLER BEARINGS WITHOUT INNER RING**  
**SERIES NK**

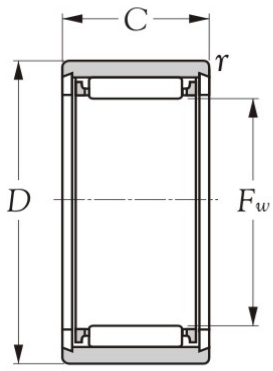

Type NK ( Fw ≤ 12mm )

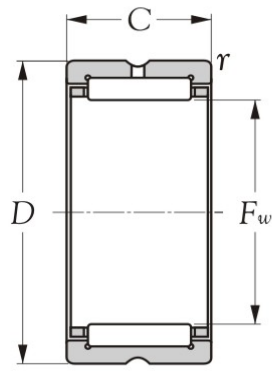

Type NK ( Fw ≥ 14mm )

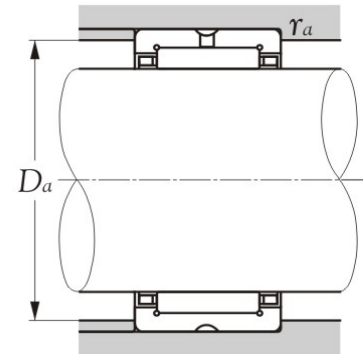
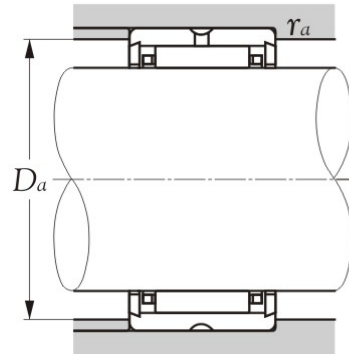

Items (20)	Data  Model nos.	Dimension			Packing method	Quantity  Min. order qty.  Pcs	Delivery  Days	-	Unit price structure  USD	2014-09-01  Unit price structure  USD	Compare percentages (%)	Production code(s)
		Bearing sizes										
		Fw	D	C								
1	NK 5/10 (5x1)	5	10	10	N2	120	90	-	1.44	-	YF	
2	NK 5/12 (5x1)	5	10	12	N2	120	90	-	1.65	-	YF	
3	NK 6/10 (10x2)	6	12	10	N2	120	90	-	1.33	-	YF	
4	NK 6/12 (10x2)	6	12	12	N2	120	90	-	1.45	-	YF	
5	NK 7/10 (5x1)	7	14	10	N2	120	90	-	1.33	-	YF	
6	NK 7/12 (5x1)	7	14	12	N2	120	90	-	1.33	-	YF	
7	NK 8/12	8	15	12	N1	250	90	-	1.33	-	YF	
8	NK 8/16	8	15	16	N1	200	90	-	1.60	-	YF	
9	NK 9/12 (5x1)	9	16	12	N2	250	90	-	0.96	-	YF	
10	NK 9/16 (5x1)	9	16	16	N2	250	90	-	1.13	-	YF	
11	* NK 10/12 (5x1)	10	17	12	N2	190	90	-	0.84	-	YF	
12	* NK 10/16 (5x1)	10	17	16	N2	170	90	-	1.03	-	YF	
13	* NK 12/12	12	19	12	N1	180	90	-	0.89	-	YF	
14	* NK 12/16	12	19	16	N1	170	90	-	0.98	-	YF	
15	* NK 14/16	14	22	16	N1	160	90	-	1.03	-	YF	
16	* NK 14/20	14	22	20	N1	130	90	-	1.25	-	YF	
17	* NK 15/16	15	23	16	N1	130	90	-	1.25	-	YF	
18	* NK 15/20	15	23	20	N1	120	90	-	1.44	-	YF	
19	* NK 16/16	16	24	16	N1	140	90	-	1.19	-	YF	
20	* NK 16/20	16	24	20	N1	110	90	-	1.44	-	YF	

<b>Remark</b>	Technical supplement		
	Cage(s)	Precision	Grease
	Steel - <input checked="" type="checkbox"/>	Class 0 (JIS)	Nil
	Polymid - <input checked="" type="checkbox"/>		
Brass - <input checked="" type="checkbox"/>			

Qualified Sub-contractor(s)	Since
YF	2004
-	-
-	-

**MACHINED-RING NEEDLE ROLLER BEARINGS WITHOUT INNER RING  
SERIES NK**

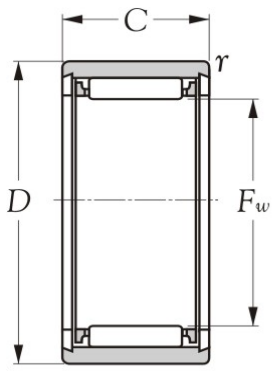

Type NK ( Fw ≤ 12mm )

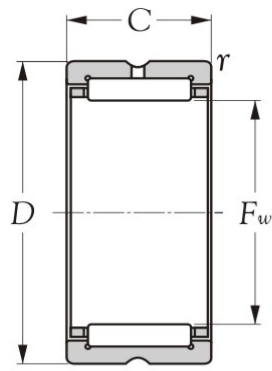

Type NK ( Fw ≥ 14mm )

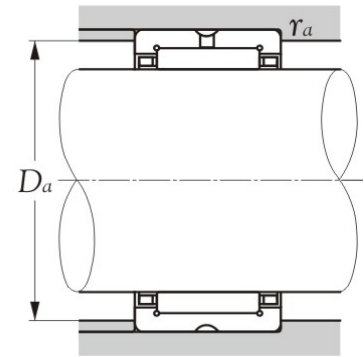
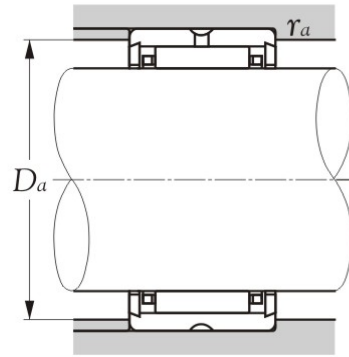

Items (20)	Data  Model nos.	Dimension			Packing method	Quantity  Min. order qty.  Pcs	Delivery  Days	-	Unit price structure  USD	2014-09-01	Compare percentages (%)	Production code(s)
		Bearing sizes								Unit price structure		
		Fw	D	C						USD		
21	* NK 17/16	17	25	16	N1	130	90	-	1.25	-	YF	
22	* NK 17/20	17	25	20	N1	100	90	-	1.60	-	YF	
23	* NK 18/16	18	26	16	N1	110	90	-	1.59	-	YF	
24	* NK 18/20	18	26	20	N1	100	90	-	1.60	-	YF	
25	* NK 19/16	19	27	16	N1	100	90	-	1.60	-	YF	
26	* NK 19/20	19	27	20	N1	100	90	-	1.60	-	YF	
27	* NK 20/16	20	28	16	N1	110	90	-	1.56	-	YF	
28	* NK 20/20	20	28	20	N1	100	90	-	1.65	-	YF	
29	* NK 21/16	21	29	16	N1	100	90	-	1.74	-	YF	
30	NK 21/20	21	29	20	N1	100	90	-	1.74	-	YF	
31	NK 22/16	22	30	16	N1	100	90	-	1.74	-	YF	
32	* NK 22/20	22	30	20	N1	100	90	-	1.74	-	YF	
33	* NK 24/16	24	32	16	N1	90	90	-	2.10	-	YF	
34	* NK 24/20	24	32	20	N1	90	90	-	2.00	-	YF	
35	* NK 25/16	25	33	16	N1	90	90	-	1.81	-	YF	
36	* NK 25/20	25	33	20	N1	90	90	-	1.81	-	YF	
37	* NK 26/16	26	34	16	N1	80	90	-	2.39	-	YF	
38	* NK 26/20	26	34	20	N1	70	90	-	2.58	-	YF	
39	* NK 28/20	28	37	20	N1	80	90	-	2.20	-	YF	
40	* NK 28/30	28	37	30	N1	70	90	-	2.61	-	YF	

<b>Remark</b>	Technical supplement		
	Cage(s)	Precision	Grease
	Steel - <input checked="" type="checkbox"/>	Class 0 (JIS)	Nil
	Polymid - <input checked="" type="checkbox"/>		
Brass - <input checked="" type="checkbox"/>			

Qualified Sub-contractor(s)	Since
YF	2004
-	-
-	-

**MACHINED-RING NEEDLE ROLLER BEARINGS WITHOUT INNER RING**  
**SERIES NK**

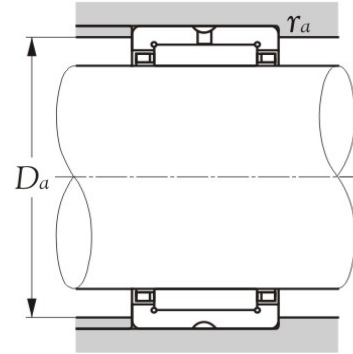
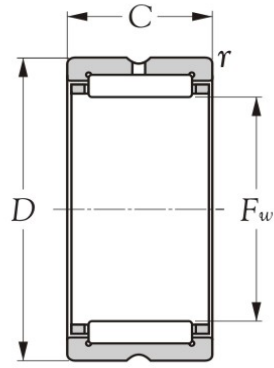

Type NK ( Fw ≥ 14mm)

Items (20)	Data  Model nos.	Dimension			Packing method	Quantity  Min. order qty.  Pcs	Delivery  Days	-		Compare percentages (%)	Production code(s)
		Bearing sizes						Unit price structure	2014-09-01 Unit price structure		
		Fw	D	C							
		mm									
41	* NK 29/20	29	38	20	N1	70	90	-	2.85	-	YF
42	* NK 29/30	29	38	30	N1	60	90	-	3.08	-	YF
43	* NK 30/20	30	40	20	N1	70	90	-	2.49	-	YF
44	* NK 30/30	30	40	30	N1	60	90	-	3.08	-	YF
45	* NK 32/20	32	42	20	N1	60	90	-	2.95	-	YF
46	* NK 32/30	32	42	30	N1	50	90	-	3.34	-	YF
47	* NK 35/20	35	45	20	N1	60	90	-	3.08	-	YF
48	* NK 35/30	35	45	30	N1	50	90	-	3.36	-	YF
49	NK 37/20	37	47	20	N1	50	90	-	3.10	-	YF
50	* NK 37/30	37	47	30	N1	40	90	-	4.08	-	YF
51	* NK 38/20	38	48	20	N1	40	90	-	4.13	-	YF
52	NK 38/30	38	48	30	N1	50	90	-	5.00	-	YF
53	* NK 40/20	40	50	20	N1	50	90	-	3.63	-	YF
54	* NK 40/30	40	50	30	N1	45	90	-	3.94	-	YF
55	* NK 42/20	42	52	20	N1	50	90	-	3.66	-	YF
56	* NK 42/30	42	52	30	N1	40	90	-	4.95	-	YF
57	NK 43/20	43	53	20	N1	40	90	-	4.24	-	YF
58	NK 43/30	43	53	30	N1	40	90	-	5.18	-	YF
59	* NK 45/20	45	55	20	N1	40	90	-	3.99	-	YF
60	* NK 45/30	45	55	30	N1	40	90	-	4.53	-	YF

Remark	Technical supplement		
	Cage(s)	Precision	Grease
	Steel - <input checked="" type="checkbox"/>	Class 0 (JIS)	Nil
	Polymid - <input checked="" type="checkbox"/>		
	Brass - <input checked="" type="checkbox"/>		

Qualified Sub-contractor(s)	Since
YF	2004
-	-
-	-



MACHINED-RING NEEDLE ROLLER BEARINGS WITHOUT INNER RING  
SERIES **NK**

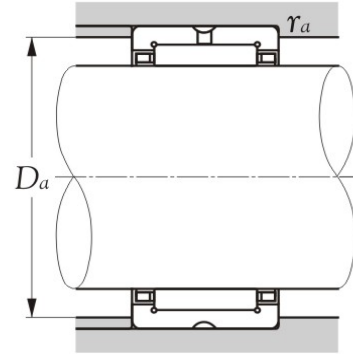
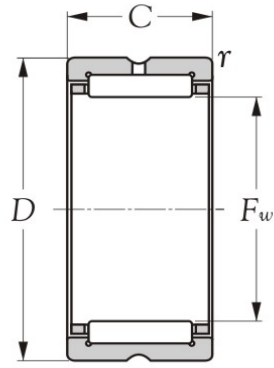

Type NK ( Fw ≥ 14mm)

Items (20)	Data  Model nos.	Dimension			Packing method	Quantity  Min. order qty.	Delivery  Days	-		Compare percentages (%)	Production code(s)
		Bearing sizes						Unit price structure	2014-09-01 Unit price structure		
		Fw	D	C							
		mm				Pcs		USD	USD		
61	* NK 47/20	47	57	20	N1	35	90	-	4.95	-	YF
62	* NK 47/30	47	57	30	N1	30	90	-	6.64	-	YF
63	* NK 50/25	50	62	25	N1	35	90	-	4.79	-	YF
64	* NK 50/35	50	62	35	N1	25	90	-	6.64	-	YF
65	* NK 55/25	55	68	25	N1	25	90	-	6.64	-	YF
66	* NK 55/35	55	68	35	N1	25	90	-	7.13	-	YF
67	* NK 60/25	60	72	25	N1	25	90	-	6.75	-	YF
68	* NK 60/35	60	72	35	N1	25	90	-	7.44	-	YF
69	* NK 65/25	65	78	25	N1	20	90	-	7.70	-	YF
70	* NK 65/35	65	78	35	N1	25	90	-	10.21	-	YF
71	NK 68/25	68	82	25	N1	25	90	-	9.18	-	YF
72	* NK 68/35	68	82	35	N1	20	90	-	11.45	-	YF
73	* NK 70/25	70	85	25	N1	15	90	-	11.74	-	YF
74	* NK 70/35	70	85	35	N1	15	90	-	12.73	-	YF
75	NK 73/25	73	90	25	N1	20	90	-	11.30	-	YF
76	NK 73/35	73	90	35	N1	20	90	-	14.14	-	YF
77	* NK 75/25	75	92	25	N1	15	90	-	12.23	-	YF
78	* NK 75/35	75	92	35	N1	15	90	-	16.81	-	YF
79	NK 80/25	85	105	25	N1	20	90	-	15.40	-	YF
80	NK 80/35	85	105	35	N1	20	90	-	19.24	-	YF

Remark	Technical supplement		
	Cage(s)	Precision	Grease
	Steel - <input checked="" type="checkbox"/>	Class 0 (JIS)	Nil
	Polymid - <input checked="" type="checkbox"/>		
	Brass - <input checked="" type="checkbox"/>		

Qualified Sub-contractor(s)	Since
YF	2004
-	-
-	-

**MACHINED-RING NEEDLE ROLLER BEARINGS WITHOUT INNER RING  
SERIES NK**

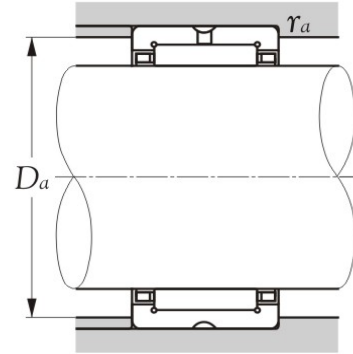
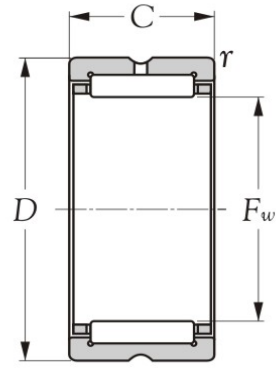

Type NK ( Fw ≥ 14mm)

Items (20)	Data  Model nos.	Dimension			Packing method	Quantity  Min. order qty.	Delivery  Days	Unit price structure  USD	2014-09-01  Unit price structure  USD	Compare percentages (%)	Production code(s)
		Bearing sizes									
		Fw	D	C							
		mm				Pcs					
81	* NK 85/25	85	105	25	N1	15	90	-	15.93	-	YF
82	NK 85/35	85	105	35	N1	20	90	-	19.90	-	YF
83	NK 90/25	90	110	25	N1	20	90	-	18.58	-	YF
84	NK 90/35	90	110	35	N1	20	90	-	23.00	-	YF
85	NK 95/26	95	115	26	N1	20	90	-	21.20	-	YF
86	NK 95/36	95	115	36	N1	20	90	-	27.41	-	YF
87	NK 100/26	100	120	26	N1	20	90	-	24.30	-	YF
88	NK 100/36	100	120	36	N1	20	90	-	30.95	-	YF
89	NK 105/26	105	125	26	N1	20	90	-	26.54	-	YF
90	NK 105/36	105	125	36	N1	20	90	-	33.60	-	YF
91	NK 110/30	110	130	30	N1	20	90	-	33.14	-	YF
92	NK 110/40	110	130	40	N1	20	90	-	39.76	-	YF
93	NK 120/40	120	140	40	N1	20	90	-	48.64	-	YF
94	NK 130/40	130	150	40	N1	-	-	-	-	-	-
95	NK 145/32	145	170	32	N1	-	-	-	-	-	-
96	NK 145/42	145	170	42	N1	-	-	-	-	-	-
97	NK 155/32	155	180	32	N1	-	-	-	-	-	-
98	NK 155/42	155	180	42	N1	-	-	-	-	-	-
99	NK 165/32	165	190	32	N1	-	-	-	-	-	-
100	NK 165/42	165	190	42	N1	-	-	-	-	-	-

Remark	Technical supplement		
	Cage(s)	Precision	Grease
	Steel - <input checked="" type="checkbox"/> Polymid - <input checked="" type="checkbox"/> Brass - <input checked="" type="checkbox"/>	Class 0 (JIS)	Nil

Qualified Sub-contractor(s)	Since
YF	2004
-	-
-	-

MACHINED-RING NEEDLE ROLLER BEARINGS WITH INNER RING  
SERIES **NKI**

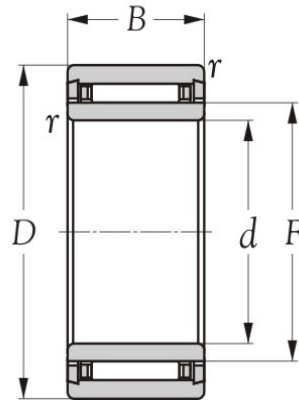

Items (20)	Data  Model nos.	Dimension			Packing method	Quantity  Min. order qty.  Pcs	Delivery  Days	Unit price structure  USD	2014-09-01  Unit price structure  USD	Compare percentages (%)	Production code(s)
		Bearing sizes									
		d	D	B							
		mm									
1	NKI 5/12	5	15	12	N1	100	90	-	2.58	-	YF
2	NKI 5/16	5	15	16	N1	100	90	-	2.84	-	YF
3	NKI 6/12 T2 (5x1)	6	16	12	N2	70	90	-	2.58	-	YF
4	NKI 6/12 (5x1)	6	16	12	N2	70	90	-	2.70	-	YF
5	NKI 6/16 T2 (5x1)	6	16	16	N1	60	90	-	2.54	-	YF
6	NKI 6/16 (5x1)	6	16	16	N2	100	90	-	2.54	-	YF
7	NKI 7/12 (5x1)	7	17	12	N2	100	90	-	2.20	-	YF
8	NKI 7/16 (5x1)	7	17	16	N2	100	90	-	2.70	-	YF
9	NKI 9/12	9	19	12	N1	100	90	-	1.80	-	YF
10	NKI 9/16	9	19	16	N1	100	90	-	2.01	-	YF
11	* NKI 10/16	10	22	16	N1	110	90	-	1.70	-	YF
12	* NKI 10/20	10	22	20	N1	90	90	-	1.86	-	YF
13	* NKI 12/16	12	24	16	N1	80	90	-	2.11	-	YF
14	* NKI 12/20	12	24	20	N1	70	90	-	2.28	-	YF
15	* NKI 15/16	15	27	16	N1	80	90	-	2.23	-	YF
16	* NKI 15/20	15	27	20	N1	70	90	-	2.36	-	YF
17	* NKI 17/16	17	29	16	N1	70	90	-	2.28	-	YF
18	* NKI 17/20	17	29	20	N1	70	90	-	2.64	-	YF
19	* NKI 20/16	20	30	16	N1	70	90	-	2.36	-	YF
20	* NKI 20/20	20	32	20	N1	60	90	-	2.78	-	YF

Remark	Technical supplement		
	Cage(s)	Precision	Grease
	Steel - <input checked="" type="checkbox"/>	Class 0 (JIS)	Nil
	Polymid - <input checked="" type="checkbox"/>		
	Brass - <input checked="" type="checkbox"/>		

Qualified Sub-contractor(s)	Since
YF	2004
-	-
-	-

MACHINED-RING NEEDLE ROLLER BEARINGS WITH INNER RING  
SERIES **NKI**

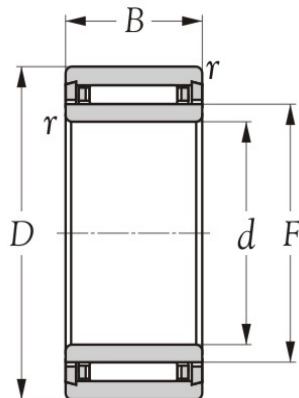

Items (20)	Data		Dimension			Packing method	Quantity Min. order qty. Pcs	Delivery Days	Unit price structure USD	2014-09-01 Unit price structure USD	Compare percentages (%)	Production code(s)
	Model nos.	Bearing sizes										
		d	D	B								
			mm									
21	* NKI 22/16	22	34	16	N1	60	90	-	2.78	-	YF	
22	* NKI 22/20	22	34	20	N1	60	90	-	3.05	-	YF	
23	* NKI 25/20	25	38	20	N1	50	90	-	3.00	-	YF	
24	* NKI 25/30	25	38	30	N1	45	90	-	3.50	-	YF	
25	* NKI 28/20	28	42	20	N1	50	90	-	3.41	-	YF	
26	* NKI 28/30	28	42	30	N1	45	90	-	3.98	-	YF	
27	* NKI 30/20	30	45	20	N1	45	90	-	3.98	-	YF	
28	* NKI 30/30	30	45	30	N1	40	90	-	4.53	-	YF	
29	* NKI 32/20	30	47	20	N1	35	90	-	4.95	-	YF	
30	* NKI 32/30	32	47	30	N1	35	90	-	4.95	-	YF	
31	* NKI 35/20	35	50	20	N1	40	90	-	4.34	-	YF	
32	* NKI 35/30	35	50	30	N1	35	90	-	4.74	-	YF	
33	* NKI 38/20	38	53	20	N1	45	90	-	4.24	-	YF	
34	* NKI 38/30	38	53	30	N1	40	90	-	5.46	-	YF	
35	* NKI 40/20	40	55	20	N1	45	90	-	5.01	-	YF	
36	* NKI 40/30	40	55	30	N1	30	90	-	6.13	-	YF	
37	* NKI 42/20	42	57	20	N1	30	90	-	6.25	-	YF	
38	* NKI 42/30	42	57	30	N1	25	90	-	8.29	-	YF	
39	* NKI 45/25	45	62	25	N1	30	90	-	6.29	-	YF	
40	* NKI 45/35	45	62	35	N1	25	90	-	7.84	-	YF	

Remark	Technical supplement		
	Cage(s)	Precision	Grease
	Steel - <input checked="" type="checkbox"/> Polymid - <input checked="" type="checkbox"/> Brass - <input checked="" type="checkbox"/>	Class 0 (JIS)	Nil

Qualified Sub-contractor(s)	Since
YF	2004
-	-
-	-

MACHINED-RING NEEDLE ROLLER BEARINGS WITH INNER RING  
SERIES **NKI**

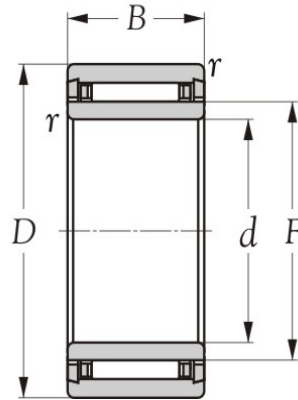

Items (20)	Data		Dimension			Packing method	Quantity		Delivery	-	2014-09-01	Compare percentages (%)	Production code(s)	
	Model nos.	Bearing sizes	Bearing sizes				Min. order qty.	Unit price structure						Unit price structure
			d	D	B									
41	* NKI 50/25	50 68 25	50	68	25	N1	25	90	-	6.81	-	YF		
42	* NKI 50/35	50 68 35	50	68	35	N1	25	90	-	8.51	-	YF		
43	* NKI 55/25	55 72 25	55	72	25	N1	25	90	-	7.59	-	YF		
44	* NKI 55/35	55 72 35	55	72	35	N1	20	90	-	9.19	-	YF		
45	NKI 60/25	60 82 25	60	82	25	N1	20	90	-	9.06	-	YF		
46	* NKI 60/35	60 82 35	60	82	35	N1	15	90	-	11.24	-	YF		
47	NKI 65/25	65 90 25	65	90	25	N1	15	90	-	10.89	-	YF		
48	NKI 65/35	65 90 35	65	90	35	N1	15	90	-	12.90	-	YF		
49	* NKI 70/25	70 95 25	70	95	25	N1	20	90	-	13.60	-	YF		
50	NKI 70/35	70 95 35	70	95	35	N1	20	90	-	17.01	-	YF		
51	NKI 75/25	75 105 25	75	105	25	N1	20	90	-	15.31	-	YF		
52	* NKI 75/35	75 105 35	75	105	35	N1	20	90	-	19.74	-	YF		
53	NKI 80/25	80 110 25	80	110	25	N1	10	90	-	19.06	-	YF		
54	NKI 80/35	80 110 35	80	110	35	N1	10	90	-	22.26	-	YF		
55	NKI 85/26	85 115 26	85	115	26	N1	20	90	-	22.75	-	YF		
56	NKI 85/36	85 115 36	85	115	36	N1	20	90	-	28.26	-	YF		
57	NKI 90/26	90 120 26	90	120	26	N1	20	90	-	27.49	-	YF		
58	NKI 90/36	90 120 36	90	120	36	N1	20	90	-	33.38	-	YF		
59	NKI 95/26	95 125 26	95	125	26	N1	20	90	-	29.44	-	YF		
60	NKI 95/36	95 125 36	95	125	36	N1	20	90	-	37.29	-	YF		

<b>Remark</b>	Technical supplement		
	Cage(s)	Precision	Grease
	Steel - <input checked="" type="checkbox"/>	Class 0 (JIS)	Nil
	Polymid - <input checked="" type="checkbox"/>		
Brass - <input checked="" type="checkbox"/>			

Qualified Sub-contractor(s)	Since
YF	2004
-	-
-	-

MACHINED-RING NEEDLE ROLLER BEARINGS WITH INNER RING  
SERIES **NKI**

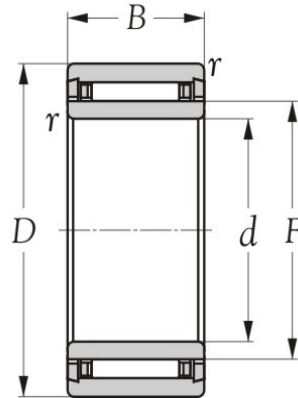

Items (2)	Data  Model nos.	Dimension			Packing method	Quantity  Min. order qty.	Delivery  Days	-		2014-09-01  Unit price structure  USD	Compare percentages (%)	Production code(s)
		Bearing sizes						Unit price structure  USD	Unit price structure  USD			
		d	D	B								
		mm				Pcs		USD	USD			
61	<b>NKI 100/30</b>	100	130	30	N1	20	90	-	<b>39.25</b>	-	YF	
62	<b>NKI 100/40</b>	100	130	40	N1	20	90	-	<b>51.04</b>	-	YF	

Remark	Technical supplement		
	Cage(s)	Precision	Grease
	Steel - <input checked="" type="checkbox"/>	Class 0 (JIS)	Nil
	Polymid - <input checked="" type="checkbox"/>		
	Brass - <input checked="" type="checkbox"/>		

Qualified Sub-contractor(s)	Since
YF	2004
-	-
-	-

**THRUST NEEDLE ROLLER BEARINGS**  
**SERIES AXK, AS, WS, GS**

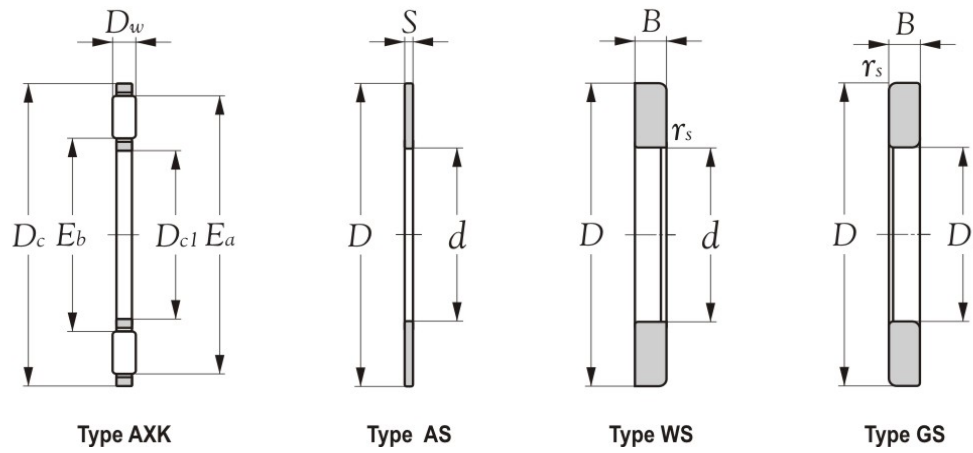

Items (20)	Data  Model nos.	Dimension			Packing method	Quantity  Min. order qty.	Delivery  Days	-		Compare percentages (%)	Production code(s)
		Bearing sizes						Unit price structure	2014-09-01 Unit price structure		
		d	D	B							
		mm				Pcs		USD	USD		
1	AXK 1100 (15x1)	10	24	2	N2	500	90	-	0.35	-	YF
2	* AXK 1101 (15x1)	12	26	2	N2	500	90	-	0.35	-	YF
3	* AXK 1102 (15x1)	15	28	2	N2	500	90	-	0.36	-	YF
4	* AXK 1103 (15x1)	17	30	2	N2	500	90	-	0.40	-	YF
5	* AXK 1104 (15x1)	20	35	2	N2	400	90	-	0.41	-	YF
6	* AXK 1105 (15x1)	25	42	2	N2	350	90	-	0.48	-	YF
7	* AXK 1106 (15x1)	30	47	2	N2	300	90	-	0.56	-	YF
8	* AXK 1107 (15x1)	35	52	2	N2	250	90	-	0.66	-	YF
9	* AXK 1108 (10x1)	40	60	3	N2	250	90	-	0.76	-	YF
10	* AXK 1109 (10x1)	45	65	3	N2	200	90	-	0.84	-	YF
11	AXK 1110 (10x1)	50	70	3	N2	200	90	-	1.03	-	YF
12	* AXK 1111 (10x1)	55	78	3	N2	150	90	-	1.24	-	YF
13	* AXK 1112 (10x1)	60	85	3	N2	120	90	-	1.51	-	YF
14	* AXK 1113 (10x1)	65	90	3	N2	100	90	-	1.74	-	YF
15	* AXK 1114 (10x1)	70	95	4	N2	80	90	-	2.06	-	YF
16	* AXK 1115 (10x1)	75	100	4	N2	70	90	-	2.39	-	YF
17	* AXK 1116 (10x1)	80	105	4	N2	60	90	-	2.78	-	YF
18	* AXK 1117 (10x1)	85	110	4	N2	50	90	-	3.25	-	YF
19	* AXK 1118 (10x1)	90	120	4	N2	45	90	-	3.78	-	YF
20	AXK 1120 (10x1)	100	135	4	N2	35	90	-	4.86	-	YF

Remark	Technical supplement		
	Cage(s)	Precision	Grease
	Steel - <input checked="" type="checkbox"/>	Class 0 (JIS)	Nil
	Polymid - <input checked="" type="checkbox"/>		
	Brass - <input checked="" type="checkbox"/>		

Qualified Sub-contractor(s)	Since
YF	2004
-	-
-	-

**THRUST NEEDLE ROLLER BEARINGS**  
**SERIES AXK, AS, WS, GS**

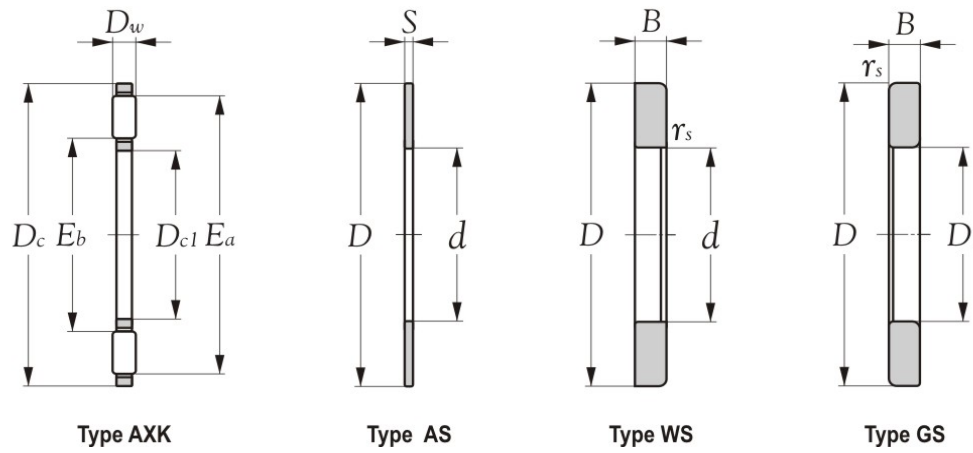

Items (20)	Data  Model nos.	Dimension			Packing method	Quantity  Min. order qty.  Pcs	Delivery  Days	-		Compare percentages (%)	Production code(s)
		Bearing sizes						Unit price structure  USD	2014-09-01 Unit price structure  USD		
		d	D	B							
		mm									
21	* AXK 1122 (10x1)	110	145	4	N2	30	90	-	5.50	-	YF
22	AXK 1124 (10x1)	120	155	4	N2	30	90	-	6.19	-	YF
23	* AXK 1126 (10x1)	130	170	5	N2	25	90	-	7.84	-	YF
24	AXK 1128 (10x1)	140	180	5	N2	20	90	-	8.58	-	YF
25	AXK 1130 (10x1)	150	190	5	N2	20	90	-	9.65	-	YF
26	AXK 1132 (10x1)	160	200	5	N2	15	90	-	11.03	-	YF
27	* AS 1100 (15x1)	10	24	1	N2	3,000	90	-	0.05	-	YF
28	* AS 1101 (15x1)	12	26	1	N2	3,000	90	-	0.05	-	YF
29	* AS 1102 (15x1)	15	28	1	N2	1,500	90	-	0.10	-	YF
30	* AS 1103 (15x1)	17	30	1	N2	1,500	90	-	0.10	-	YF
31	* AS 1104 (15x1)	20	35	1	N2	1,500	90	-	0.10	-	YF
32	* AS 1105 (15x1)	25	42	1	N2	1,500	90	-	0.10	-	YF
33	* AS 1106 (15x1)	30	47	1	N2	1,000	90	-	0.15	-	YF
34	* AS 1107 (15x1)	35	52	1	N2	1,000	90	-	0.15	-	YF
35	* AS 1108 (15x1)	40	60	1	N2	1,000	90	-	0.19	-	YF
36	* AS 1109 (15x1)	45	65	1	N2	900	90	-	0.21	-	YF
37	* AS 1110 (15x1)	50	70	1	N2	800	90	-	0.26	-	YF
38	* AS 1111 (15x1)	55	78	1	N2	700	90	-	0.30	-	YF
39	* AS 1112 (15x1)	60	85	1	N2	500	90	-	0.40	-	YF
40	* AS 1113 (15x1)	65	90	1	N2	400	90	-	0.48	-	YF

<b>Remark</b>	Technical supplement		
	Cage(s)	Precision	Grease
	Steel - <input checked="" type="checkbox"/>	Class 0 (JIS)	Nil
	Polymid - <input checked="" type="checkbox"/>		
Brass - <input checked="" type="checkbox"/>			

Qualified Sub-contractor(s)	Since
YF	2004
-	-
-	-



**THRUST NEEDLE ROLLER BEARINGS**  
**SERIES AXK, AS, WS, GS**

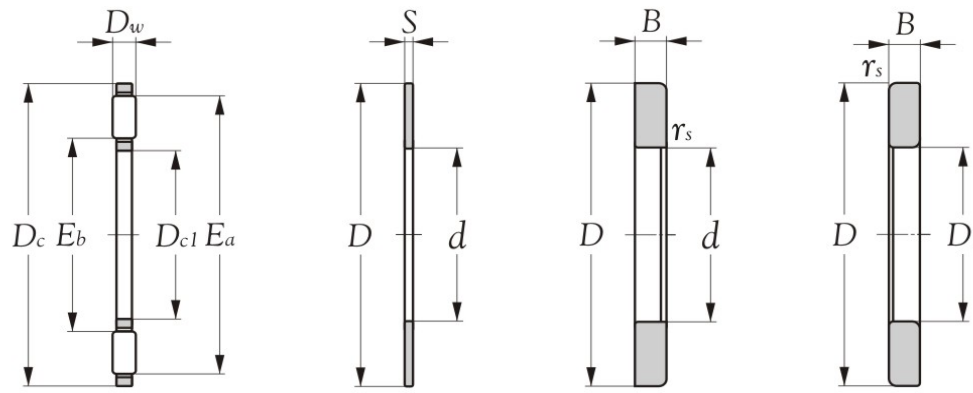

Type AXK

Type AS

Type WS

Type GS

Items (20)	Data  Model nos.	Dimension			Packing method	Quantity  Min. order qty.  Pcs	Delivery  Days	-	2014-09-01	Compare percentages (%)	Production code(s)		
		Bearing sizes										Unit price structure  USD	Unit price structure  USD
		d	D	B									
		mm											
41	* AS 1114 (15x1)	70	95	1	N2	350	90	-	0.56	-	YF		
42	* AS 1115 (15x1)	75	100	1	N2	300	90	-	0.66	-	YF		
43	* AS 1116 (15x1)	80	105	1	N2	200	90	-	0.79	-	YF		
44	* AS 1117 (15x1)	85	110	1	N2	200	90	-	0.81	-	YF		
45	* AS 1118 (15x1)	90	120	1	N2	200	90	-	1.01	-	YF		
46	* AS 1120 (15x1)	100	135	1	N2	140	90	-	1.24	-	YF		
47	* AS 1122 (15x1)	110	145	1	N2	120	90	-	1.44	-	YF		
48	AS 1124 (15x1)	120	155	1	N2	110	90	-	1.64	-	YF		
49	* AS 1126 (15x1)	130	170	1	N2	100	90	-	1.80	-	YF		
50	AS 1128 (15x1)	140	180	1	N2	90	90	-	1.96	-	YF		
51	AS 1130 (15x1)	150	190	1	N2	250	90	-	2.11	-	YF		
52	AS 1132 (15x1)	160	200	1	N2	70	90	-	2.49	-	YF		
53	WS 1100 (10x1)	10	24	2.75	N2	200	90	-	0.84	-	YF		
54	WS 1101 (10x1)	12	26	2.75	N2	200	90	-	0.84	-	YF		
55	WS 1102 (10x1)	15	28	2.75	N2	200	90	-	0.84	-	YF		
56	WS 1103 (10x1)	17	30	2.75	N2	200	90	-	0.84	-	YF		
57	WS 1104 (10x1)	20	35	2.75	N2	200	90	-	0.91	-	YF		
58	WS 1105 (10x1)	25	42	3	N2	200	90	-	0.96	-	YF		
59	WS 1106 (10x1)	30	47	3	N2	200	90	-	1.05	-	YF		
60	WS 1107 (10x1)	35	52	3.5	N2	200	90	-	1.23	-	YF		

<b>Remark</b>	Technical supplement		
	Cage(s)	Precision	Grease
	Steel - <input checked="" type="checkbox"/>	Class 0 (JIS)	Nil
	Polymid - <input checked="" type="checkbox"/>		
Brass - <input checked="" type="checkbox"/>			

Qualified Sub-contractor(s)	Since
YF	2004
-	-
-	-

**THRUST NEEDLE ROLLER BEARINGS**  
**SERIES AXK, AS, WS, GS**

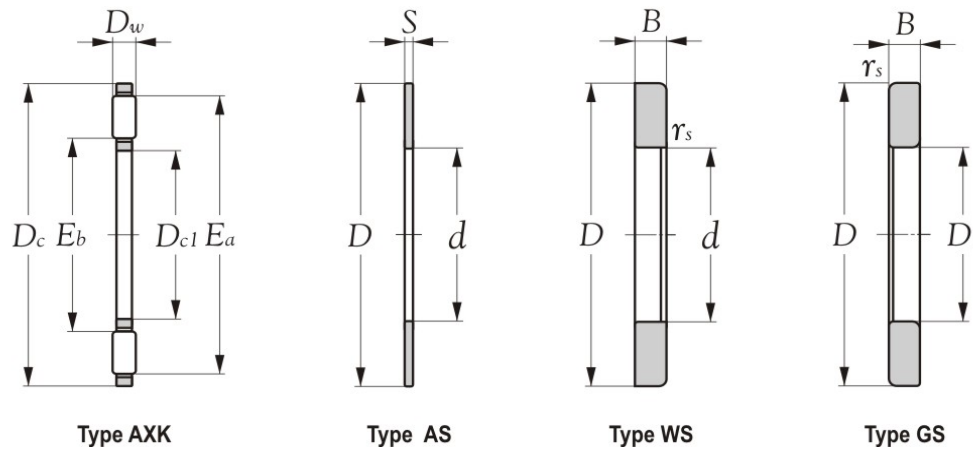

Items (20)	Data  Model nos.	Dimension			Packing method	Quantity  Min. order qty.  Pcs	Delivery  Days	-	2014-09-01	Compare percentages (%)	Production code(s)		
		Bearing sizes										Unit price structure  USD	Unit price structure  USD
		d	D	B									
		mm											
61	WS 1108 (10x1)	40	60	3.5	N2	1,200	90	-	1.40	-	YF		
62	WS 1109 (10x1)	45	65	4	N2	1,200	90	-	1.64	-	YF		
63	WS 1110 (10x1)	50	70	4	N2	1,000	90	-	1.96	-	YF		
64	WS 1111 (10x1)	55	78	5	N2	1,000	90	-	2.29	-	YF		
65	WS 1112 (10x1)	60	85	4.75	N2	500	90	-	2.66	-	YF		
66	WS 1113 (10x1)	65	90	5.25	N2	500	90	-	3.15	-	YF		
67	WS 1114 (10x1)	70	95	5.25	N2	500	90	-	3.39	-	YF		
68	WS 1115 (10x1)	75	100	5.75	N2	500	90	-	3.83	-	YF		
69	WS 1116 (10x1)	80	105	5.75	N2	500	90	-	4.58	-	YF		
70	WS 1117 (10x1)	85	110	5.75	N2	400	90	-	5.04	-	YF		
71	WS 1118 (5x1)	90	120	6.5	N2	400	90	-	5.66	-	YF		
72	WS 1120	100	135	7	N1	200	90	-	8.63	-	YF		
73	WS 1122	110	145	7	N1	200	90	-	11.00	-	YF		
74	WS 1124	120	155	7	N1	150	90	-	13.73	-	YF		
75	WS 1126	130	170	9	N1	100	90	-	17.68	-	YF		
76	WS 1128	140	180	9.5	N1	100	90	-	21.59	-	YF		
77	WS 1130	150	190	9.5	N1	100	90	-	24.33	-	YF		
78	WS 1132	160	200	9.5	N1	100	90	-	27.48	-	YF		
79	GS 1100 (10x1)	10	24	2.75	N2	500	90	-	0.79	-	YF		
80	GS 1101 (10x1)	12	26	2.75	N2	500	90	-	0.79	-	YF		

<b>Remark</b>	Technical supplement		
	Cage(s)	Precision	Grease
	Steel - <input checked="" type="checkbox"/>	Class 0 (JIS)	Nil
	Polymid - <input checked="" type="checkbox"/>		
Brass - <input checked="" type="checkbox"/>			

Qualified Sub-contractor(s)	Since
-	-
-	-
-	-

**THRUST NEEDLE ROLLER BEARINGS**  
**SERIES AXK, AS, WS, GS**

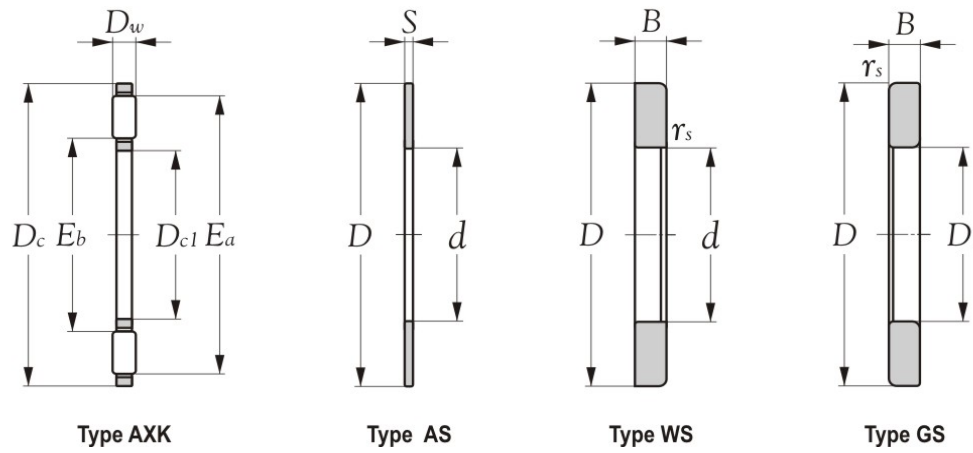

Items (20)	Data  Model nos.	Dimension			Packing method	Quantity  Min. order qty.  Pcs	Delivery  Days	-		2014-09-01  Unit price structure  USD	Compare percentages (%)	Production code(s)
		Bearing sizes						Unit price structure	Unit price structure			
		d	D	B								
		mm						USD	USD			
81	GS 1102 (10x1)	15	28	2.75	N2	500	90	-	0.79	-	YF	
82	GS 1103 (10x1)	17	30	2.75	N2	500	90	-	0.79	-	YF	
83	GS 1104 (10x1)	20	35	2.75	N2	500	90	-	0.84	-	YF	
84	GS 1105 (5x1)	25	42	3	N2	500	90	-	0.93	-	YF	
85	GS 1106 (5x1)	30	47	3	N2	500	90	-	1.05	-	YF	
86	GS 1107 (5x1)	35	52	3.5	N2	500	90	-	1.23	-	YF	
87	GS 1108 (5x1)	40	60	3.5	N2	500	90	-	1.34	-	YF	
88	GS 1109 (5x1)	45	65	4	N2	500	90	-	1.45	-	YF	
89	GS 1110 (5x1)	50	70	4	N2	300	90	-	1.80	-	YF	
90	GS 1111 (5x1)	55	78	5	N2	300	90	-	2.06	-	YF	
91	GS 1112 (5x1)	60	85	4.75	N2	200	90	-	2.49	-	YF	
92	GS 1113 (5x1)	65	90	5.25	N2	200	90	-	2.99	-	YF	
93	GS 1114 (5x1)	70	95	5.25	N2	200	90	-	3.25	-	YF	
94	GS 1115 (5x1)	75	100	5.75	N2	150	90	-	3.66	-	YF	
95	GS 1116 (5x1)	80	105	5.75	N2	150	90	-	4.24	-	YF	
96	GS 1117 (5x1)	85	110	5.75	N2	150	90	-	4.74	-	YF	
97	GS 1118 (5x1)	90	120	6.5	N2	100	90	-	5.28	-	YF	
98	GS 1120	100	135	7	N1	60	90	-	8.25	-	YF	
99	GS 1122	110	145	7	N1	60	90	-	10.59	-	YF	
100	GS 1124	120	155	7	N1	50	90	-	13.35	-	YF	

<b>Remark</b>	Technical supplement		
	Cage(s)	Precision	Grease
	Steel - <input checked="" type="checkbox"/>	Class 0 (JIS)	Nil
	Polymid - <input checked="" type="checkbox"/>		
Brass - <input checked="" type="checkbox"/>			

Qualified Sub-contractor(s)	Since
-	-
-	-
-	-

**THRUST NEEDLE ROLLER BEARINGS**  
**SERIES AXK, AS, WS, GS**

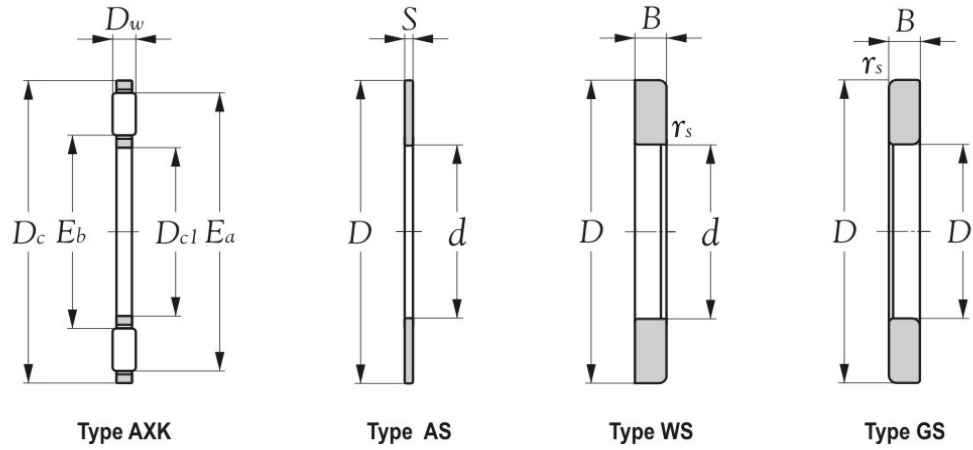

Items (4)	Data  Model nos.	Dimension			Packing method	Quantity  Min. order qty.	Delivery  Days	-		Compare percentages (%)	Production code(s)
		Bearing sizes						Unit price structure	2014-09-01 Unit price structure		
		d	D	B							
		mm				Pcs		USD	USD		
101	GS 1126	130	170	9	N1	50	90	-	17.26	-	YF
102	GS 1128	140	180	9.5	N1	40	90	-	21.20	-	YF
103	GS 1130	150	190	9.5	N1	30	90	-	23.96	-	YF
104	GS 1132	160	200	9.5	N1	30	90	-	27.08	-	YF

<b>Remark</b>	Technical supplement		
	Cage(s)	Precision	Grease
	Steel - <input checked="" type="checkbox"/>	Class 0 (JIS)	Nil
	Polymid - <input checked="" type="checkbox"/>		
Brass - <input checked="" type="checkbox"/>			

Qualified Sub-contractor(s)	Since
-	-
-	-
-	-

**THRUST NEEDLE ROLLER BEARINGS**  
**SERIES LS**

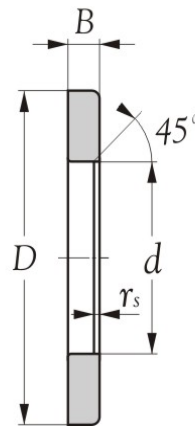

Items (20)	Data  Model nos.	Dimension			Packing method	Quantity  Min. order qty.	Delivery  Days	Unit price structure  USD	2014-09-01  Unit price structure  USD	Compare percentages (%)	Production code(s)
		Bearing sizes									
		d	D	B							
		mm				Pcs					
1	LS 0619 (10x1)	6	19	2.75	N2	300	90	-	0.74	-	YF
2	LS 0821 (10x1)	8	21	2.75	N2	300	90	-	0.74	-	YF
3	LS 1024 (10x1)	10	24	2.75	N2	300	90	-	0.78	-	YF
4	LS 1226 (10x1)	12	26	2.75	N2	300	90	-	0.78	-	YF
5	* LS 1528 (10x1)	15	28	2.75	N2	300	90	-	0.78	-	YF
6	* LS 1730 (10x1)	17	30	2.75	N2	300	90	-	0.78	-	YF
7	* LS 2035 (10x1)	20	35	2.75	N2	300	90	-	0.79	-	YF
8	* LS 2542 (10x1)	25	42	3	N2	300	90	-	0.89	-	YF
9	LS 3047 (10x1)	30	47	3	N2	160	90	-	1.14	-	YF
10	* LS 3552 (10x1)	35	52	3.5	N2	160	90	-	1.14	-	YF
11	LS 4060 (10x1)	40	60	3.5	N2	120	90	-	1.44	-	YF
12	LS 4565 (10x1)	45	65	4	N2	100	90	-	1.70	-	YF
13	LS 5070 (10x1)	50	70	4	N2	90	90	-	1.96	-	YF
14	LS 5578 (10x1)	55	78	5	N2	80	90	-	2.23	-	YF
15	LS 6085 (10x1)	60	85	4.75	N2	60	90	-	3.11	-	YF
16	LS 6090 (10x1)	65	90	5.25	N2	50	90	-	3.56	-	YF
17	LS 7095 (10x1)	70	95	5.25	N2	50	90	-	3.66	-	YF
18	LS 75100 (10x1)	75	100	5.75	N2	40	90	-	0.99	-	YF
19	LS 80105 (10x1)	80	105	5.75	N2	40	90	-	4.58	-	YF
20	LS 85110 (10x1)	85	110	5.75	N2	35	90	-	5.04	-	YF

<b>Remark</b>	Technical supplement		
	Cage(s)	Precision	Grease
	Steel - <input checked="" type="checkbox"/>	Class 0 (JIS)	Nil
	Polymid - <input checked="" type="checkbox"/>		
Brass - <input checked="" type="checkbox"/>			

Qualified Sub-contractor(s)	Since
YF	2004
-	-
-	-

**THRUST NEEDLE ROLLER BEARINGS**  
**SERIES LS**

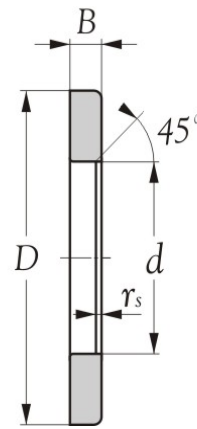

Items (3)	Data  Model nos.	Dimension			Packing method	Quantity  Min. order qty.	Delivery  Days	-		Compare percentages (%)	Production code(s)
		Bearing sizes						Unit price structure	2014-09-01 Unit price structure		
		d	D	B							
		mm				Pcs		USD	USD		
21	LS 90120 (5x1)	90	120	6.5	N2	30	90	-	5.50	-	YF
22	LS 100135 (5x1)	100	135	7	N2	25	90	-	6.86	-	YF
23	LS 110145 (5x1)	110	145	7	N2	20	90	-	8.03	-	YF

<b>Remark</b>	Technical supplement		
	Cage(s)	Precision	Grease
	Steel - <input checked="" type="checkbox"/>	Class 0 (JIS)	Nil
	Polymid - <input checked="" type="checkbox"/>		
Brass - <input checked="" type="checkbox"/>			

Qualified Sub-contractor(s)	Since
YF	2004
-	-
-	-

**THRUST NEEDLE ROLLER BEARINGS**  
**SERIES K 811**

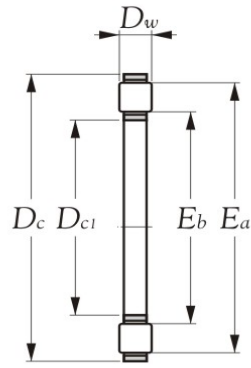

Type K 811

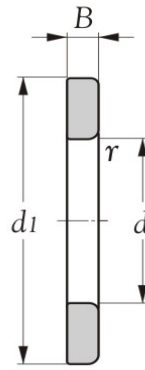

Type WS  
(Inner ring)

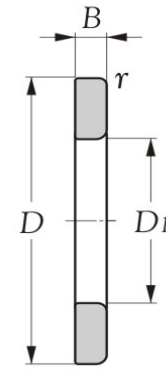

Type GS  
(Outer ring)

Items (20)	Data  Model nos.	Dimension			Packing method	Quantity  Min. order qty.	Delivery  Days	-		Compare percentages (%)	Production code(s)
		Bearing sizes						Unit price structure	2014-09-01 Unit price structure		
		Eb	Dc	Dw							
mm			Pcs	USD	USD						
1	K 81100 (10x1)	12	24	3.5	N2	500	90	-	0.78	-	YF
2	K 81101 (10x1)	14	26	3.5	N2	500	90	-	0.96	-	YF
3	K 81102 (10x1)	16	28	3.5	N2	500	90	-	1.03	-	YF
4	K 81103 (10x1)	18	30	3.5	N2	500	90	-	1.10	-	YF
5	K 81104 (10x1)	21	35	4.5	N2	500	90	-	1.18	-	YF
6	K 81105 (5x1)	27	42	5	N2	500	90	-	1.30	-	YF
7	K 81106 (5x1)	32	47	5	N2	400	90	-	1.43	-	YF
8	K 81107 (5x1)	37	52	5	N2	400	90	-	1.59	-	YF
9	K 81108 (5x1)	42	60	6	N2	400	90	-	1.75	-	YF
10	K 81109 (5x1)	47	65	6	N2	350	90	-	1.98	-	YF
11	K 81110 (5x1)	52	70	6	N2	350	90	-	2.15	-	YF
12	K 81111 (5x1)	57	78	6	N2	350	90	-	2.36	-	YF
13	K 81112 (5x1)	63	85	7.5	N2	300	90	-	2.95	-	YF
14	K 81113 (5x1)	68	90	7.5	N2	250	90	-	3.53	-	YF
15	* K 81114 (5x1)	73	95	7.5	N2	200	90	-	4.33	-	YF
16	K 81115 (5x1)	78	100	7.5	N2	200	90	-	4.90	-	YF
17	K 81116 (5x1)	83	105	7.5	N2	150	90	-	5.50	-	YF
18	K 81117 (5x1)	88	110	7.5	N2	100	90	-	6.28	-	YF
19	K 81118 (5x1)	93	120	9	N2	50	90	-	7.46	-	YF
20	WS 81100 (10x1)	10	24	2.75	N2	400	90	-	0.40	-	YF

<b>Remark</b>	Technical supplement		
	Cage(s)	Precision	Grease
	Steel - <input checked="" type="checkbox"/>	Class 0 (JIS)	Nil
	Polymid - <input checked="" type="checkbox"/>		
Brass - <input checked="" type="checkbox"/>			

Qualified Sub-contractor(s)	Since
YF	2004
-	-
-	-

**THRUST NEEDLE ROLLER BEARINGS**  
**SERIES K 811**

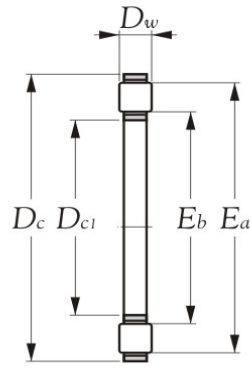

Type K 811

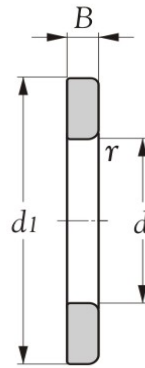

Type WS  
(Inner ring)

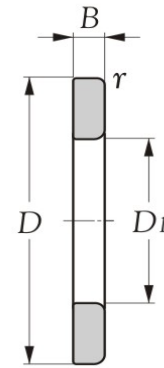

Type GS  
(Outer ring)

Items (20)	Data  Model nos.	Dimension			Packing method	Quantity  Min. order qty.	Delivery  Days	-	2014-09-01	Compare percentages (%)	Production code(s)		
		Bearing sizes										Unit price structure	Unit price structure
		Eb	Dc	Dw									
		mm				Pcs		USD					
21	WS 81101 (10x1)	12	26	2.75	N2	350	90	-	0.50	-	YF		
22	WS 81102 (10x1)	15	28	2.75	N2	350	90	-	0.50	-	YF		
23	WS 81103 (10x1)	17	30	2.75	N2	350	90	-	0.50	-	YF		
24	WS 81104 (10x1)	20	35	2.75	N2	250	90	-	0.63	-	YF		
25	WS 81105 (10x1)	25	42	3	N2	210	90	-	0.74	-	YF		
26	WS 81106 (10x1)	30	47	3	N2	170	90	-	0.99	-	YF		
27	WS 81107 (10x1)	35	52	3.5	N2	150	90	-	1.10	-	YF		
28	WS 81108 (10x1)	40	60	3.5	N2	130	90	-	1.30	-	YF		
29	WS 81109 (10x1)	45	65	4	N2	110	90	-	1.51	-	YF		
30	WS 81110 (10x1)	50	70	4	N2	90	90	-	1.80	-	YF		
31	WS 81111 (10x1)	55	78	5	N2	80	90	-	2.11	-	YF		
32	WS 81112 (10x1)	60	85	4.75	N2	70	90	-	2.48	-	YF		
33	WS 81113 (10x1)	65	90	5.25	N2	60	90	-	2.99	-	YF		
34	WS 81114 (10x1)	70	95	5.25	N2	60	90	-	3.19	-	YF		
35	WS 81115 (10x1)	75	100	5.75	N2	45	90	-	3.58	-	YF		
36	WS 81116 (10x1)	80	105	5.75	N2	40	90	-	4.28	-	YF		
37	WS 81117 (10x1)	85	110	5.75	N2	35	90	-	4.73	-	YF		
38	WS 81118 (5x1)	90	120	6.5	N2	35	90	-	5.28	-	YF		
39	GS 81100 (10x1)	10	24	3.5	N2	450	90	-	0.40	-	YF		
40	GS 81101 (10x1)	12	26	3.5	N2	350	90	-	0.50	-	YF		

<b>Remark</b>	Technical supplement		
	Cage(s)	Precision	Grease
	Steel - <input checked="" type="checkbox"/>	Class 0 (JIS)	Nil
	Polymid - <input checked="" type="checkbox"/>		
Brass - <input checked="" type="checkbox"/>			

Qualified Sub-contractor(s)	Since
YF	2004
-	-
-	-



**THRUST NEEDLE ROLLER BEARINGS  
SERIES K 811**

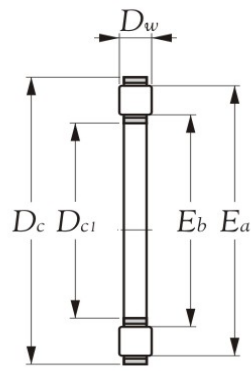

Type K 811

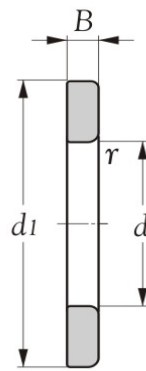

Type WS  
(Inner ring)

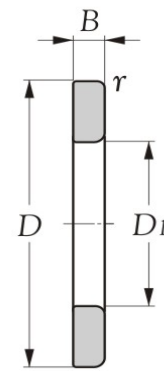

Type GS  
(Outer ring)

Items (17)	Data  Model nos.	Dimension			Packing method	Quantity  Min. order qty.	Delivery  Days	-	2014-09-01	Compare percentages (%)	Production code(s)		
		Bearing sizes										Unit price structure	Unit price structure
		<i>E<sub>b</sub></i>	<i>D<sub>c</sub></i>	<i>D<sub>w</sub></i>									
		mm				Pcs		USD	USD				
41	GS 81102 (10x1)	15	28	3.5	N2	350	90	-	0.50	-	YF		
42	GS 81103 (10x1)	17	30	3.5	N2	350	90	-	0.50	-	YF		
43	GS 81104 (10x1)	20	35	4.5	N2	300	90	-	0.58	-	YF		
44	GS 81105 (5x1)	25	42	5	N2	250	90	-	0.66	-	YF		
45	GS 81106 (5x1)	30	47	5	N2	200	90	-	0.99	-	YF		
46	GS 81107 (5x1)	35	52	5	N2	150	90	-	1.10	-	YF		
47	GS 81108 (5x1)	40	60	6	N2	140	90	-	1.25	-	YF		
48	GS 81109 (5x1)	45	65	6	N2	120	90	-	1.39	-	YF		
49	GS 81110 (5x1)	50	70	6	N2	100	90	-	1.69	-	YF		
50	GS 81111 (5x1)	55	78	6	N2	90	90	-	1.93	-	YF		
51	GS 81112 (5x1)	60	85	7.5	N2	70	90	-	2.34	-	YF		
52	GS 81113 (5x1)	65	90	7.5	N2	60	90	-	2.79	-	YF		
53	GS 81114 (5x1)	70	95	7.5	N2	60	90	-	3.04	-	YF		
54	GS 81115 (5x1)	75	100	7.5	N2	50	90	-	3.41	-	YF		
55	GS 81116 (5x1)	80	105	7.5	N2	45	90	-	3.98	-	YF		
56	GS 81117 (5x1)	85	110	7.5	N2	40	90	-	4.44	-	YF		
57	GS 81118 (5x1)	90	120	9	N2	35	90	-	4.94	-	YF		

<b>Remark</b>	Technical supplement		
	Cage(s)	Precision	Grease
	Steel - <input checked="" type="checkbox"/>	Class 0 (JIS)	Nil
	Polymid - <input checked="" type="checkbox"/>		
Brass - <input checked="" type="checkbox"/>			

Qualified Sub-contractor(s)	Since
YF	2004
-	-
-	-

**THRUST NEEDLE ROLLER BEARINGS**  
**SERIES K 812**

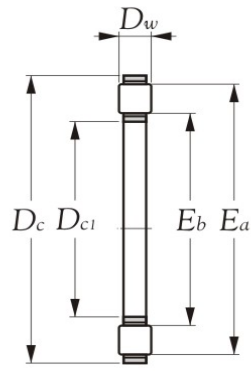

Type K 812

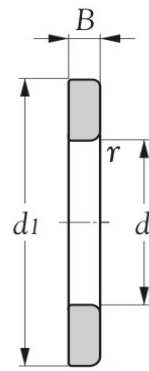

Type WS  
(Inner ring)

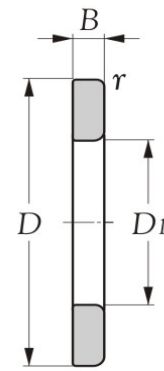

Type GS  
(Outer ring)

Items (20)	Data  Model nos.	Dimension			Packing method	Quantity  Min. order qty.	Delivery	-		2014-09-01	Compare percentages (%)	Production code(s)
		Bearing sizes						Unit price structure	Unit price structure			
		<i>E<sub>b</sub></i>	<i>D<sub>c</sub></i>	<i>D<sub>w</sub></i>								
mm			Pcs	Days	USD	USD						
1	K 81206	32	52	7.5	N1	200	90	-	1.98	-	YF	
2	K 81207	37	62	7.5	N1	200	90	-	2.36	-	YF	
3	K 81208	43	68	9	N1	150	90	-	2.75	-	YF	
4	K 81209	48	73	9	N1	150	90	-	3.15	-	YF	
5	K 81210	53	78	9	N1	150	90	-	3.53	-	YF	
6	K 81211	58	90	11	N1	150	90	-	3.91	-	YF	
7	K 81212	64	95	11	N1	100	90	-	4.74	-	YF	
8	K 81213	69	100	11	N1	100	90	-	5.89	-	YF	
9	K 81214	74	105	11	N1	80	90	-	7.06	-	YF	
10	K 81215	79	110	11	N1	80	90	-	8.25	-	YF	
11	K 81216	84	115	11	N1	80	90	-	9.81	-	YF	
12	WS 81206	-	-	-	-	-	-	-	-	-	-	
13	WS 81207	-	-	-	-	-	-	-	-	-	-	
14	WS 81208	-	-	-	-	-	-	-	-	-	-	
15	WS 81209	-	-	-	-	-	-	-	-	-	-	
16	WS 81210	-	-	-	-	-	-	-	-	-	-	
17	WS 81211	-	-	-	-	-	-	-	-	-	-	
18	WS 81212	-	-	-	-	-	-	-	-	-	-	
19	WS 81213	-	-	-	-	-	-	-	-	-	-	
20	WS 81214	-	-	-	-	-	-	-	-	-	-	

<b>Remark</b>	Technical supplement		
	Cage(s)	Precision	Grease
	Steel - <input checked="" type="checkbox"/>	Class 0 (JIS)	Nil
	Polymid - <input checked="" type="checkbox"/>		
Brass - <input checked="" type="checkbox"/>			

Qualified Sub-contractor(s)	Since
YF	2004
-	-
-	-

**THRUST NEEDLE ROLLER BEARINGS  
SERIES K 812**

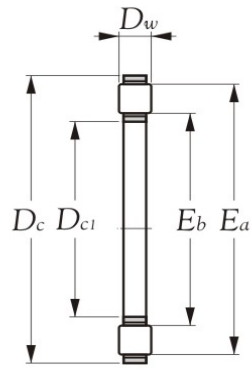

Type K 812

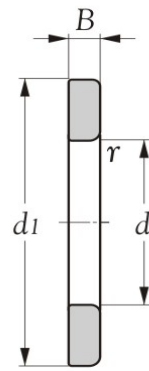

Type WS  
(Inner ring)

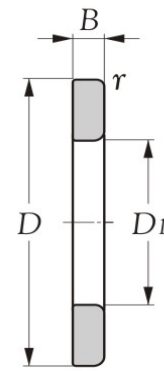

Type GS  
(Outer ring)

Items (13)	Data	Dimension			Packing method	Quantity Min. order qty.	Delivery	-	2014-09-01	Compare percentages (%)	Production code(s)		
	Model nos.	Bearing sizes										Unit price structure	Unit price structure
		<i>Eb</i>	<i>Dc</i>	<i>Dw</i>									
			mm			Pcs	Days	USD	USD				
21	WS 81215	-	-	-	-	-	-	-	-	-	-		
22	WS 81216	-	-	-	-	-	-	-	-	-	-		
23	GS 81206	-	-	-	-	-	-	-	-	-	-		
24	GS 81207	-	-	-	-	-	-	-	-	-	-		
25	GS 81208	-	-	-	-	-	-	-	-	-	-		
26	GS 81209	-	-	-	-	-	-	-	-	-	-		
27	GS 81210	-	-	-	-	-	-	-	-	-	-		
28	GS 81211	-	-	-	-	-	-	-	-	-	-		
29	GS 81212	-	-	-	-	-	-	-	-	-	-		
30	GS 81213	-	-	-	-	-	-	-	-	-	-		
31	GS 81214	-	-	-	-	-	-	-	-	-	-		
32	GS 81215	-	-	-	-	-	-	-	-	-	-		
33	GS 81216	-	-	-	-	-	-	-	-	-	-		

<b>Remark</b>	Technical supplement		
	Cage(s)	Precision	Grease
	Steel - <input checked="" type="checkbox"/>	Class 0 (JIS)	Nil
	Polymid - <input checked="" type="checkbox"/>		
Brass - <input checked="" type="checkbox"/>			

Qualified Sub-contractor(s)	Since
-	-
-	-
-	-

NEEDLE ROLLER BEARINGS WITH THRUST BALL BEARINGS  
SERIES **NKX, NKX..Z**

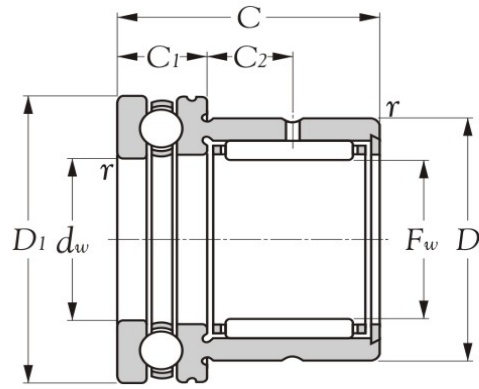

Type NKX  
(Open type)

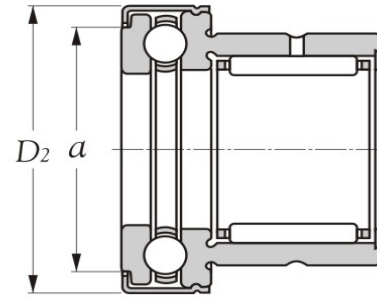

Type NKX..Z  
(With cover)

Items (20)	Data  Model nos.	Dimension			Packing method	Quantity  Min. order qty.  Pcs	Delivery  Days	-		Compare percentages (%)	Production code(s)
		Bearing sizes						Unit price structure  USD	2014-09-01 Unit price structure  USD		
		Fw	D1	C							
1	NKX 10	10	24	23	N1	80	120	-	6.74	-	YF
2	NKX 12	12	26	23	N1	80	120	-	6.74	-	YF
3	NKX 15	15	28	23	N1	80	120	-	7.75	-	YF
4	NKX 17	17	30	25	N1	80	120	-	8.44	-	YF
5	* NKX 20	20	36	30	N1	70	120	-	10.01	-	YF
6	* NKX 25	25	42	30	N1	60	120	-	11.54	-	YF
7	* NKX 30	30	47	30	N1	50	120	-	13.35	-	YF
8	NKX 35	35	52	30	N1	45	120	-	14.69	-	YF
9	NKX 40	40	60	32	N1	40	120	-	16.00	-	YF
10	NKX 45	45	65	32	N1	35	120	-	17.58	-	YF
11	NKX 50	50	70	35	N1	35	120	-	18.93	-	YF
12	NKX 60	60	85	40	N1	30	120	-	21.80	-	YF
13	NKX 70	70	95	40	N1	25	120	-	28.93	-	YF
14	NKX 10 Z	10	24	23	N1	80	120	-	7.38	-	YF
15	NKX 12 Z	12	26	23	N1	80	120	-	7.38	-	YF
16	NKX 15 Z	15	29	23	N1	80	120	-	8.44	-	YF
17	NKX 17 Z	17	31	25	N1	70	120	-	9.34	-	YF
18	* NKX 20 Z	20	36	30	N1	60	120	-	10.93	-	YF
19	* NKX 25 Z	25	43	30	N1	50	120	-	12.48	-	YF
20	* NKX 30 Z	30	48	30	N1	45	120	-	14.49	-	YF

<b>Remark</b>	Technical supplement		
	Cage(s)	Precision	Grease
	Steel - <input checked="" type="checkbox"/>	Class 0 (JIS)	Nil
	Polymid - <input checked="" type="checkbox"/>		
Brass - <input checked="" type="checkbox"/>			

Qualified Sub-contractor(s)	Since
YF	2004
-	-
-	-

NEEDLE ROLLER BEARINGS WITH THRUST BALL BEARINGS  
SERIES **NKX, NKX..Z**

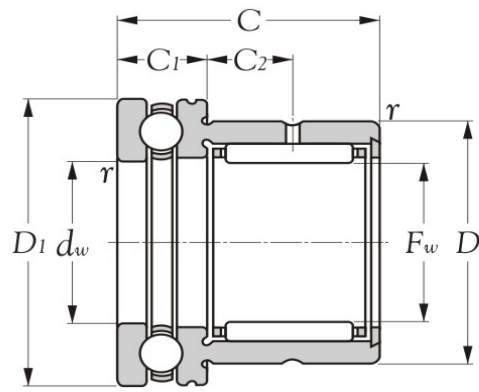

Type NKX  
(Open type)

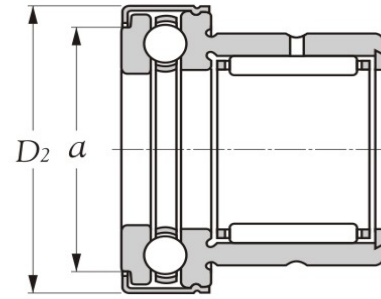

Type NKX..Z  
(With cover)

Items (6)	Data  Model nos.	Dimension			Packing method	Quantity  Min. order qty.	Delivery  Days	-		Compare percentages (%)	Production code(s)
		Bearing sizes						Unit price structure	2014-09-01 Unit price structure		
		<i>F<sub>w</sub></i>	<i>D<sub>1</sub></i>	<i>C</i>							
		mm				Pcs		USD	USD		
21	* NKX 35 Z	35	53	30	N1	40	120	-	16.00	-	YF
22	* NKX 40 Z	40	61	32	N1	40	120	-	17.34	-	YF
23	* NKX 45 Z	45	66.5	32	N1	35	120	-	18.93	-	YF
24	* NKX 50 Z	50	71.5	35	N1	30	120	-	20.46	-	YF
25	* NKX 60 Z	60	86.5	40	N1	30	120	-	23.36	-	YF
26	NKX 70 Z	70	96.5	40	N1	20	120	-	30.69	-	YF

<b>Remark</b>	Technical supplement	Precision	Grease
	Cage(s)		
	Steel - ✓	Class 0 (JIS)	Nil
	Polymid - ✗		
Brass - ✗			

Qualified Sub-contractor(s)	Since
YF	2004
-	-
-	-

NEEDLE ROLLER BEARINGS WITH THRUST CYLINDRICAL ROLLER BEARINGS  
SERIES **NKXR, NKXR..Z**

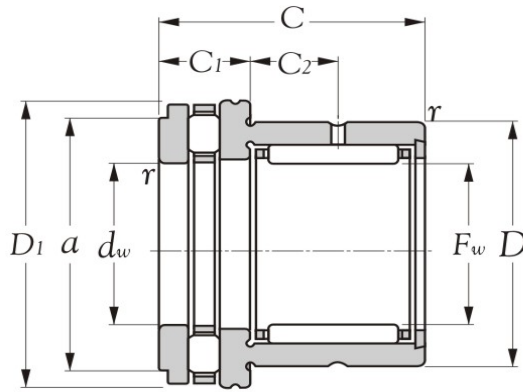

Type NKXR  
(Open type)

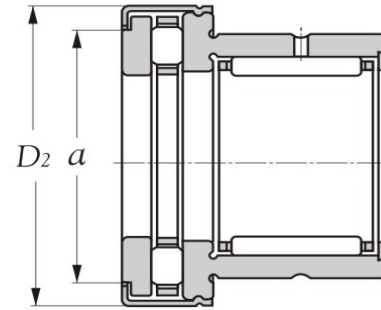

Type NKXR..Z  
(With cover)

Items (18)	Data  Model nos.	Dimension			Packing method	Quantity  Min. order qty.	Delivery  Days	-	2014-09-01	Compare percentages (%)	Production code(s)		
		Bearing sizes										Unit price structure	Unit price structure
		Fw	D1	C									
		mm				Pcs							
1	NKXR 15	15	28	23	N1	100	120	-	9.60	-	YF		
2	NKXR 17	17	30	25	N1	100	120	-	10.21	-	YF		
3	NKXR 20	20	35	30	N1	90	120	-	12.64	-	YF		
4	NKXR 25	25	42	30	N1	70	120	-	15.61	-	YF		
5	NKXR 30	30	47	30	N1	50	120	-	17.41	-	YF		
6	NKXR 35	35	52	30	N1	50	120	-	20.43	-	YF		
7	* NKXR 40	40	60	32	N1	50	120	-	23.43	-	YF		
8	NKXR 45	45	65	32	N1	50	120	-	26.46	-	YF		
9	NKXR 50	50	70	35	N1	50	120	-	35.48	-	YF		
10	NKXR 15 Z	15	29	23	N1	100	120	-	10.21	-	YF		
11	NKXR 17 Z	17	31	25	N1	100	120	-	10.81	-	YF		
12	* NKXR 20 Z	20	36	30	N1	90	120	-	13.21	-	YF		
13	NKXR 25 Z	25	43	30	N1	70	120	-	16.24	-	YF		
14	NKXR 30 Z	30	48	30	N1	50	120	-	18.04	-	YF		
15	NKXR 35 Z	35	53	30	N1	50	120	-	21.04	-	YF		
16	NKXR 40 Z	40	61	32	N1	50	120	-	24.04	-	YF		
17	NKXR 45 Z	45	66.5	32	N1	50	120	-	27.04	-	YF		
18	NKXR 50 Z	50	71.5	35	N1	50	120	-	36.08	-	YF		

Remark	Technical supplement		
	Cage(s)	Precision	Grease
	Steel - <input checked="" type="checkbox"/> Polymid - <input checked="" type="checkbox"/> Brass - <input checked="" type="checkbox"/>	Class 0 (JIS)	Nil

Qualified Sub-contractor(s)	Since
YF	2004
-	-
-	-

NEEDLE ROLLER BEARINGS WITH ANGULAR CONTACT BALL BEARINGS  
SERIES **NKIA 59**

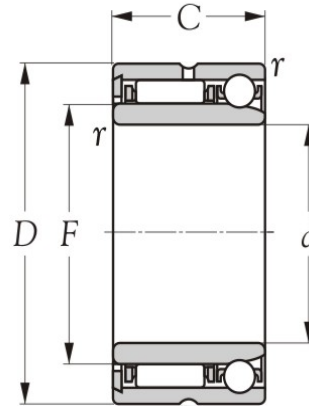

Items (14)	Data  Model nos.	Dimension			Packing method	Quantity  Min. order qty.  Pcs	Delivery  Days	-	2014-09-01	Compare percentages (%)	Production code(s)		
		Bearing sizes										Unit price structure  USD	Unit price structure  USD
		d	D	C									
		mm											
1	* NKIA 5902	15	28	18	N1	180	120	-	4.95	-	YF		
2	NKIA 5903	17	30	18	N1	170	120	-	4.95	-	YF		
3	NKIA 5904	20	37	23	N1	160	120	-	6.09	-	YF		
4	NKIA 59/22	22	39	23	N1	160	120	-	7.15	-	YF		
5	NKIA 5905	25	42	23	N1	130	120	-	7.33	-	YF		
6	NKIA 5906	30	47	23	N1	120	120	-	8.39	-	YF		
7	NKIA 5907	35	55	27	N1	100	120	-	9.80	-	YF		
8	NKIA 5908	40	62	30	N1	90	120	-	9.90	-	YF		
9	NKIA 5909	45	68	30	N1	70	120	-	15.26	-	YF		
10	NKIA 5910	50	72	30	N1	60	120	-	17.00	-	YF		
11	NKIA 5911	55	80	34	N1	45	120	-	21.09	-	YF		
12	NKIA 5912	60	85	34	N1	40	120	-	23.83	-	YF		
13	NKIA 5913	65	90	34	N1	40	120	-	25.56	-	YF		
14	NKIA 5914	70	100	40	N1	35	120	-	27.29	-	YF		

Remark	Technical supplement		
	Cage(s)	Precision	Grease
	Steel - ✓	Class 0 (JIS)	Nil
	Polymid - ✗		
	Brass - ✗		

Qualified Sub-contractor(s)	Since
YF	2004
-	-
-	-

NEEDLE ROLLER BEARINGS WITH THREE-POINT CONTACT BALL BEARINGS  
SERIES **NKIB 59**

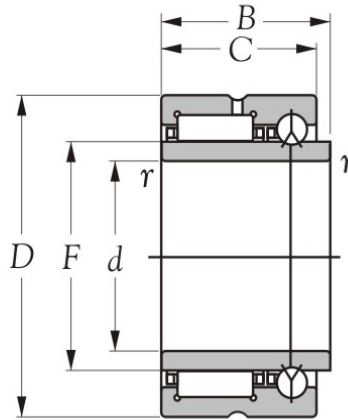

Items (14)	Data  Model nos.	Dimension			Packing method	Quantity  Min. order qty.  Pcs	Delivery  Days	-		2014-09-01  Unit price structure  USD	Compare percentages (%)	Production code(s)
		Bearing sizes						Unit price structure	Unit price structure			
		d	D	B								
		mm						USD	USD			
1	* NKIB 5902 R	15	28	20	N1	140	120	-	6.51	-	YF	
2	* NKIB 5903 R	17	30	20	N1	120	120	-	6.75	-	YF	
3	NKIB 5904 R	20	37	25	N1	100	120	-	8.58	-	YF	
4	NKIB 59/22 R	22	39	25	N1	100	120	-	9.43	-	YF	
5	NKIB 5905 R	25	42	25	N1	90	120	-	9.84	-	YF	
6	NKIB 5906 R	30	47	25	N1	80	120	-	10.36	-	YF	
7	NKIB 5907 R	35	55	30	N1	70	120	-	13.36	-	YF	
8	NKIB 5908 R	40	62	34	N1	60	120	-	16.81	-	YF	
9	NKIB 5909 R	45	68	34	N1	50	120	-	18.00	-	YF	
10	NKIB 5910 R	50	72	34	N1	40	120	-	23.21	-	YF	
11	NKIB 5911 R	55	80	38	N1	35	120	-	24.75	-	YF	
12	NKIB 5912 R	60	85	38	N1	35	120	-	27.23	-	YF	
13	NKIB 5913 R	65	90	38	N1	35	120	-	30.61	-	YF	
14	NKIB 5914 R	70	100	45	N1	30	120	-	32.39	-	YF	

Remark	Technical supplement		
	Cage(s)	Precision	Grease
	Steel - ✓	Class 0 (JIS)	Nil
	Polymid - ✗		
	Brass - ✗		

Qualified Sub-contractor(s)	Since
YF	2004
-	-
-	-



ROLLER FOLLOWERS YOKE TYPE TRUCK ROLLERS  
SERIES **NATR**

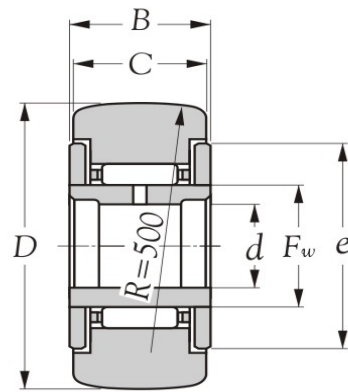

Type NATR  
(With cage)

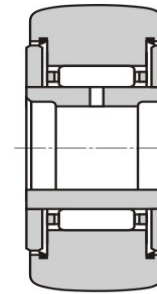

Type NATR..LL  
(Sealed type with cage)

Items (20)	Data  Model nos.	Dimension			Packing method	Quantity  Min. order qty.  Pcs	Delivery  Days	-	2014-09-01	Compare percentages (%)	Production code(s)		
		Bearing sizes										Unit price structure  USD	Unit price structure  USD
		d	D	B									
		mm											
1	NATR 5 (5x1)	5	16	12	N2	120	90	-	3.15	-	YF		
2	NATR 6	6	19	12	N1	100	90	-	3.41	-	YF		
3	* NATR 8	8	24	15	N1	90	90	-	3.83	-	YF		
4	* NATR 10	10	30	15	N1	100	90	-	3.56	-	YF		
5	* NATR 12	12	32	15	N1	90	90	-	3.94	-	YF		
6	* NATR 15	15	35	19	N1	80	90	-	4.58	-	YF		
7	* NATR 17	17	40	21	N1	70	90	-	5.01	-	YF		
8	* NATR 20	20	47	25	N1	60	90	-	6.00	-	YF		
9	* NATR 25	25	52	25	N1	70	90	-	6.45	-	YF		
10	* NATR 30	30	62	29	N1	40	90	-	8.80	-	YF		
11	NATR 35	35	72	29	N1	35	90	-	10.35	-	YF		
12	NATR 40	40	80	32	N1	30	90	-	12.39	-	YF		
13	NATR 45	45	85	32	N1	30	90	-	13.78	-	YF		
14	NATR 50	50	90	32	N1	20	90	-	17.33	-	YF		
15	* NATR 5 LL (5x1)	5	16	12	N2	110	90	-	3.20	-	YF		
16	* NATR 6 LL	6	19	12	N1	100	90	-	3.49	-	YF		
17	* NATR 8 LL	8	24	15	N1	110	90	-	3.34	-	YF		
18	* NATR 10 LL	10	30	15	N1	110	90	-	3.63	-	YF		
19	* NATR 12 LL	12	32	15	N1	90	90	-	4.03	-	YF		
20	* NATR 15 LL	15	35	19	N1	80	90	-	4.48	-	YF		

<b>Remark</b>	Technical supplement		
	Cage(s)	Precision	Grease
	Steel - <input checked="" type="checkbox"/>	Class 0 (JIS)	Alvania S2 -25°C~+120°C
	Polymid - <input checked="" type="checkbox"/>		
Brass - <input checked="" type="checkbox"/>			

Qualified Sub-contractor(s)	Since
YF	2004
-	-
-	-

ROLLER FOLLOWERS YOKE TYPE TRUCK ROLLERS  
SERIES **NATR**

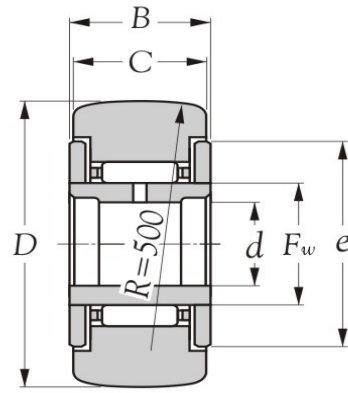

Type NATR  
(With cage)

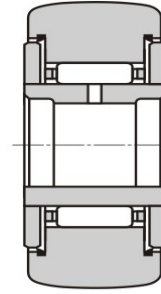

Type NATR..LL  
(Sealed type with cage)

Items (8)	Data  Model nos.	Dimension			Packing method	Quantity  Min. order qty.	Delivery  Days	-		Compare percentages (%)	Production code(s)
		Bearing sizes						Unit price structure	2014-09-01 Unit price structure		
		d	D	B							
		mm				Pcs		USD	USD		
21	* NATR 17 LL	17	40	21	N1	70	90	-	5.09	-	YF
22	* NATR 20 LL	20	47	25	N1	60	90	-	5.83	-	YF
23	* NATR 25 LL	25	52	25	N1	50	90	-	7.00	-	YF
24	* NATR 30 LL	30	62	29	N1	45	90	-	8.51	-	YF
25	* NATR 35 LL	35	72	29	N1	40	90	-	10.10	-	YF
26	* NATR 40 LL	40	80	32	N1	35	90	-	11.90	-	YF
27	* NATR 45 LL	45	85	32	N1	30	90	-	13.61	-	YF
28	NATR 50 LL	50	90	32	N1	25	90	-	15.99	-	YF

<b>Remark</b>	Technical supplement		
	Cage(s)	Precision	Grease
	Steel - <input checked="" type="checkbox"/>	Class 0 (JIS)	Alvania S2 -25°C~+120°C
	Polymid - <input checked="" type="checkbox"/>		
Brass - <input checked="" type="checkbox"/>			

Qualified Sub-contractor(s)	Since
YF	2004
-	-
-	-

**ROLLER FOLLOWERS YOKE TYPE TRUCK ROLLERS  
SERIES NATV**

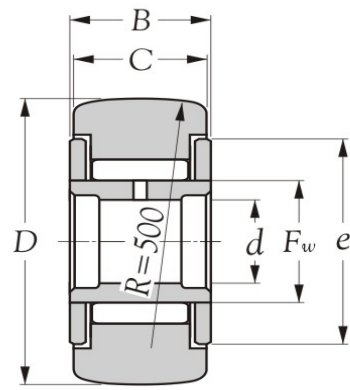

**Type NATV**  
(Full complement type)

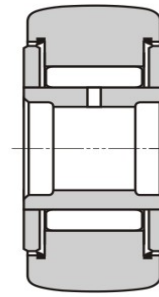

**Type NATV..LL**  
(Full complement type with seals)

Items (20)	Data  Model nos.	Dimension			Packing method	Quantity  Min. order qty.  Pcs	Delivery  Days	-	2014-09-01	Compare percentages (%)	Production code(s)		
		Bearing sizes										Unit price structure  USD	Unit price structure  USD
		d	D	B									
		mm											
1	NATV 5 (5x1)	5	16	12	N2	110	90	-	3.25	-	YF		
2	NATV 6	6	19	12	N1	100	90	-	3.49	-	YF		
3	NATV 8	8	24	15	N1	100	90	-	3.58	-	YF		
4	NATV 10	10	30	15	N1	100	90	-	3.58	-	YF		
5	NATV 12	12	32	15	N1	90	90	-	3.90	-	YF		
6	NATV 15	15	35	19	N1	80	90	-	4.75	-	YF		
7	NATV 17	17	40	21	N1	80	90	-	5.05	-	YF		
8	NATV 20	20	47	25	N1	60	90	-	5.89	-	YF		
9	NATV 25	25	52	25	N1	50	90	-	7.10	-	YF		
10	NATV 30	30	62	29	N1	40	90	-	9.04	-	YF		
11	NATV 35	35	72	29	N1	35	90	-	10.05	-	YF		
12	NATV 40	40	80	32	N1	30	90	-	11.98	-	YF		
13	NATV 50	50	90	32	N1	25	90	-	15.93	-	YF		
14	* NATV 5 LL (5x1)	5	16	12	N2	110	90	-	3.34	-	YF		
15	* NATV 6 LL	6	19	12	N1	110	90	-	3.66	-	YF		
16	* NATV 8 LL	8	24	15	N1	90	90	-	4.18	-	YF		
17	* NATV 10 LL	10	30	15	N1	90	90	-	3.91	-	YF		
18	* NATV 12 LL	12	32	15	N1	80	90	-	4.38	-	YF		
19	* NATV 15 LL	15	35	19	N1	70	90	-	5.04	-	YF		
20	* NATV 17 LL	17	40	21	N1	70	90	-	5.50	-	YF		

Remark	Technical supplement		
	Cage(s)	Precision	Grease
	Steel - <input checked="" type="checkbox"/> Polymid - <input checked="" type="checkbox"/> Brass - <input checked="" type="checkbox"/>	Class 0 (JIS)	Alvania S2 -25°C~+120°C

Qualified Sub-contractor(s)	Since
YF	2004
-	-
-	-

ROLLER FOLLOWERS YOKE TYPE TRUCK ROLLERS  
SERIES **NATV**

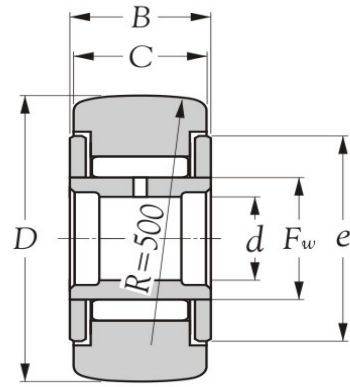

Type NATV  
(Full complement type)

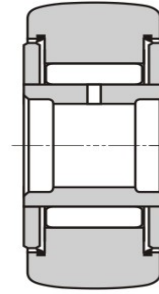

Type NATV..LL  
(Full complement type with seals)

Items (6)	Data  Model nos.	Dimension			Packing method	Quantity  Min. order qty.	Delivery  Days	-		Compare percentages (%)	Production code(s)
		Bearing sizes						Unit price structure	Unit price structure		
		d	D	B							
mm			Pcs	USD	USD						
21	* NATV 20 LL	20	47	25	N1	60	90	-	6.41	-	YF
22	* NATV 25 LL	25	52	25	N1	50	90	-	7.59	-	YF
23	* NATV 30 LL	30	62	29	N1	45	90	-	8.51	-	YF
24	NATV 35 LL	35	72	29	N1	35	90	-	10.21	-	YF
25	* NATV 40 LL	40	80	32	N1	30	90	-	11.90	-	YF
26	NATV 50 LL	50	90	32	N1	20	90	-	17.74	-	YF

<b>Remark</b>	Technical supplement		Precision	Grease
	Cage(s)			
	Steel -	✓	Class 0 (JIS)	Alvania S2 -25°C~+120°C
	Polymid -	×		
Brass -	×			

Qualified Sub-contractor(s)	Since
YF	2004
-	-
-	-

**ROLLER FOLLOWERS YOKE TYPE TRUCK ROLLERS**  
**SERIES NUTR**

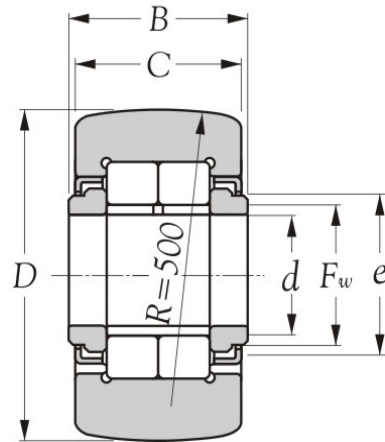

Items (18)	Data  Model nos.	Dimension			Packing method	Quantity  Min. order qty.  Pcs	Delivery  Days	Unit price structure  USD	2014-09-01  Unit price structure  USD	Compare percentages (%)	Production code(s)
		Bearing sizes									
		d	D	B							
1	* NUTR 202	15	35	19	N1	60	90	-	5.48	-	YF
2	* NUTR 203	17	40	21	N1	60	90	-	5.91	-	YF
3	* NUTR 302	15	42	19	N1	50	90	-	6.75	-	YF
4	NUTR 303	17	47	21	N1	50	90	-	7.05	-	YF
5	* NUTR 204	20	47	25	N1	50	90	-	6.75	-	YF
6	* NUTR 304	20	52	25	N1	45	90	-	7.65	-	YF
7	* NUTR 205	25	52	25	N1	45	90	-	7.64	-	YF
8	* NUTR 305	25	62	25	N1	40	90	-	8.58	-	YF
9	* NUTR 206	30	62	29	N1	40	90	-	8.25	-	YF
10	* NUTR 306	30	72	29	N1	40	90	-	8.55	-	YF
11	* NUTR 207	35	72	29	N1	35	90	-	9.76	-	YF
12	* NUTR 307	35	80	29	N1	35	90	-	10.36	-	YF
13	* NUTR 208	40	80	32	N1	30	90	-	11.51	-	YF
14	* NUTR 209	45	85	32	N1	25	90	-	13.10	-	YF
15	* NUTR 308	40	90	32	N1	30	90	-	14.33	-	YF
16	* NUTR 210	50	90	32	N1	25	90	-	15.53	-	YF
17	* NUTR 309	45	100	32	N1	20	90	-	16.78	-	YF
18	* NUTR 310	50	110	32	N1	20	90	-	18.04	-	YF

Remark	Technical supplement		
	Cage(s)	Precision	Grease
	Steel - ✓	Class 0 (JIS)	Alvania S2 -25°C~+120°C
	Polymid - ×		
	Brass - ×		

Qualified Sub-contractor(s)	Since
YF	2004
-	-
-	-

ROLLER FOLLOWERS YOKE TYPE TRUCK ROLLERS SEALED TYPE  
SERIES **NA22..LL, RNA22..LL**

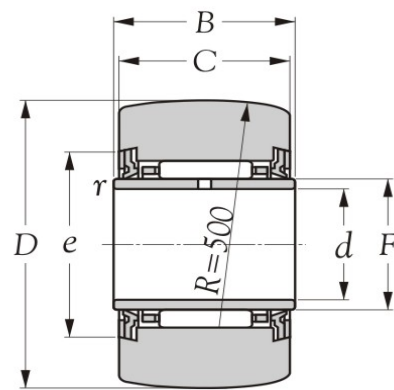

Type NA22..LL  
(With inner ring)

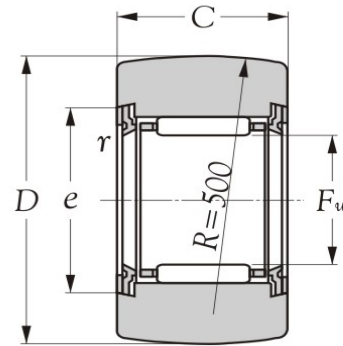

Type RNA22..LL  
(Without inner ring)

Items (20)	Data  Model nos.	Dimension			Packing method	Quantity  Min. order qty.  Pcs	Delivery  Days	-	2014-09-01	Compare percentages (%)	Production code(s)		
		Bearing sizes										Unit price structure  USD	Unit price structure  USD
		d	D	B									
		mm											
1	NA 22/6 LL	6	19	12	N1	70	90	-	4.53	-	YF		
2	NA 22/8 LL	8	24	12	N1	70	90	-	4.53	-	YF		
3	* NA 2200 LL	10	30	14	N1	70	90	-	4.95	-	YF		
4	* NA 2201 LL	12	32	14	N1	70	90	-	5.09	-	YF		
5	* NA 2202 LL	15	35	14	N1	70	90	-	5.36	-	YF		
6	* NA 2203 LL	17	40	16	N1	70	90	-	5.89	-	YF		
7	* NA 2204 LL	20	47	18	N1	70	90	-	6.30	-	YF		
8	* NA 2205 LL	25	52	18	N1	70	90	-	7.49	-	YF		
9	* NA 2206 LL	30	62	20	N1	70	90	-	8.25	-	YF		
10	NA 2207 LL	35	72	23	N1	70	90	-	10.30	-	YF		
11	NA 2208 LL	40	80	23	N1	70	90	-	12.38	-	YF		
12	NA 2209 LL	45	85	23	N1	60	90	-	14.43	-	YF		
13	NA 2210 LL	50	90	23	N1	50	90	-	16.46	-	YF		
14	RNA 22/6 LL	6	19	12	N1	250	90	-	3.30	-	YF		
15	RNA 22/8 LL	8	24	12	N1	250	90	-	3.30	-	YF		
16	RNA 2200 LL	10	30	14	N1	250	90	-	3.30	-	YF		
17	RNA 2201 LL	12	32	14	N1	250	90	-	3.73	-	YF		
18	RNA 2202 LL	15	35	14	N1	200	90	-	4.13	-	YF		
19	RNA 2203 LL	17	40	16	N1	200	90	-	4.55	-	YF		
20	RNA 2204 LL	20	47	18	N1	200	90	-	4.95	-	YF		

Remark	Technical supplement		
	Cage(s)	Precision	Grease
	Steel - <input checked="" type="checkbox"/>	Class 0 (JIS)	Alvania S2 -25°C~+120°C
	Polymid - <input checked="" type="checkbox"/>		
	Brass - <input checked="" type="checkbox"/>		

Qualified Sub-contractor(s)	Since
YF	2004
-	-
-	-

ROLLER FOLLOWERS YOKE TYPE TRUCK ROLLERS SEALED TYPE  
SERIES **NA22..LL, RNA22..LL**

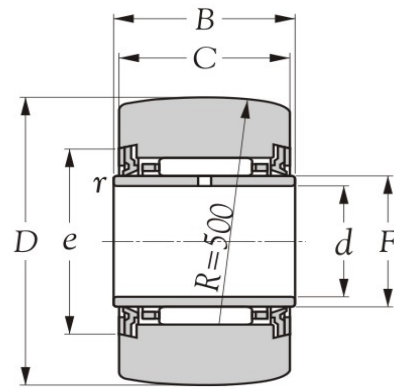

Type NA22..LL  
(With inner ring)

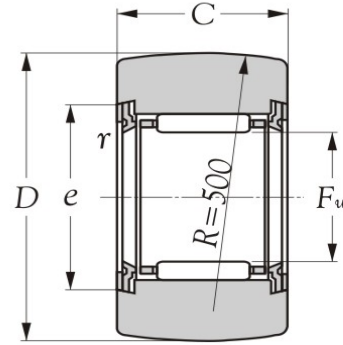

Type RNA22..LL  
(Without inner ring)

Items (6)	Data  Model nos.	Dimension			Packing method	Quantity  Min. order qty.	Delivery  Days	-	2014-09-01	Compare percentages (%)	Production code(s)		
		Bearing sizes										Unit price structure	Unit price structure
		d	D	B									
		mm				Pcs		USD	USD				
21	RNA 2205 LL	25	52	18	N1	200	90	-	5.79	-	YF		
22	RNA 2206 LL	30	62	20	N1	150	90	-	6.64	-	YF		
23	RNA 2207 LL	35	72	23	N1	100	90	-	8.68	-	YF		
24	RNA 2208 LL	40	80	23	N1	100	90	-	10.35	-	YF		
25	RNA 2209 LL	45	85	23	N1	100	90	-	12.43	-	YF		
26	RNA 2210 LL	50	90	23	N1	80	90	-	14.50	-	YF		

Remark	Technical supplement							
	Cage(s)	Precision	Grease					
	<table border="1"> <tr> <td>Steel -</td> <td>✓</td> </tr> <tr> <td>Polymid -</td> <td>×</td> </tr> <tr> <td>Brass -</td> <td>×</td> </tr> </table>	Steel -	✓	Polymid -	×	Brass -	×	Class 0 (JIS)
Steel -	✓							
Polymid -	×							
Brass -	×							

Qualified Sub-contractor(s)	Since
YF	2004
-	-
-	-

CAM FOLLOWERS STUD TYPE TRUCK ROLLERS

SERIES KR

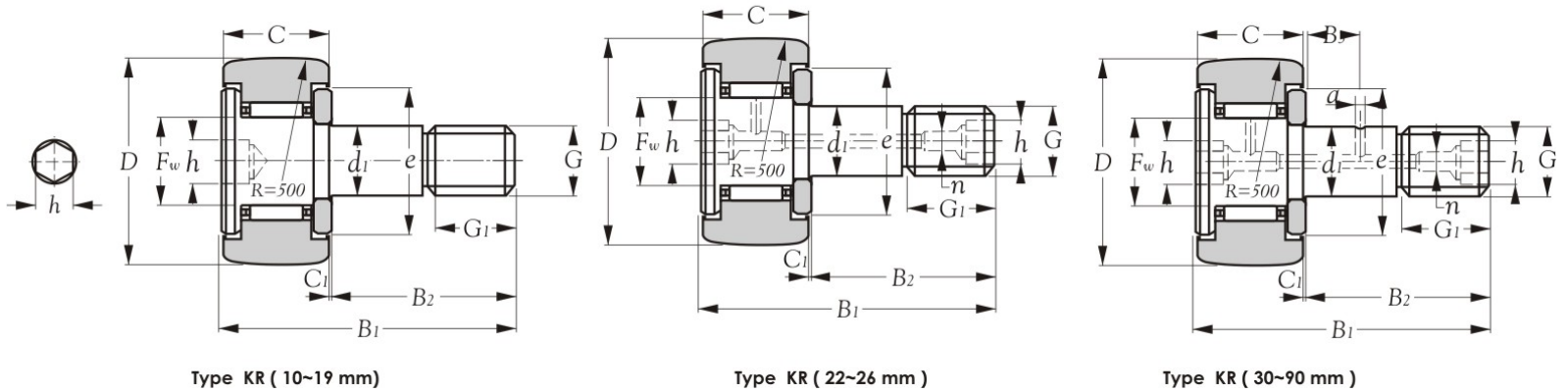

Items (18)	Data  Model nos.	Dimension			Packing method	Quantity  Min. order qty.	Delivery	-			
		Bearing sizes						Unit price structure	2014-09-01 Unit price structure	Compare percentages (%)	Production code(s)
		Fw	D	B1							
			mm			Pcs	Days	USD	USD		
1	KR 10 (5x1)	7	10	17	N2	-	-	-	-	-	-
2	KR 12 (10x1)	8	12	20	N2	-	-	-	-	-	-
3	KR 13 (10x1)	9	13	23	N2	-	90	-	5.40	-	YF
4	KR 16	11	16	28	N1	100	90	-	3.58	-	YF
5	KR 19	11	19	32	N1	90	90	-	4.18	-	YF
6	KR 22	12	22	36	N1	90	90	-	4.29	-	YF
7	* KR 26	12	26	36	N1	70	90	-	5.09	-	YF
8	* KR 30	14	30	40	N1	70	90	-	5.50	-	YF
9	* KR 32	14	32	40	N1	60	90	-	5.79	-	YF
10	KR 35	18	35	52	N1	60	90	-	6.86	-	YF
11	KR 40	20	40	58	N1	45	90	-	8.39	-	YF
12	* KR 47	24	47	66	N1	35	90	-	10.00	-	YF
13	KR 52	24	52	66	N1	35	90	-	11.10	-	YF
14	* KR 62	29	62	80	N1	30	90	-	13.05	-	YF
15	KR 72	29	72	80	N1	30	90	-	14.70	-	YF
16	KR 80	35	80	100	N1	25	90	-	17.93	-	YF
17	KR 85	35	85	100	N1	20	90	-	21.96	-	YF
18	KR 90	35	90	100	N1	15	90	-	27.23	-	YF

- Remark : 1. Production before May,2010, all the bearings have only one axial hole.  
 2. Production after May,2010, bearings which inner Dia. ≤19mm, have one axial hole; bearings which inner Dia. >19mm have 2 axial holes.  
 3. Production after Oct,2010, KR 47, KR 52 matched with 2# Nipples.

Remark	Technical supplement		
	Cage(s)	Precision	Grease
	Steel - ✓ Polymid - ✗ Brass - ✗	Class 0 (JIS)	Alvania S2 -25℃~+120℃

Qualified Sub-contractor(s)	Since
YF	2004
-	-
-	-



**CAM FOLLOWERS STUD TYPE TRUCK ROLLERS**  
**SERIES KR..LL**

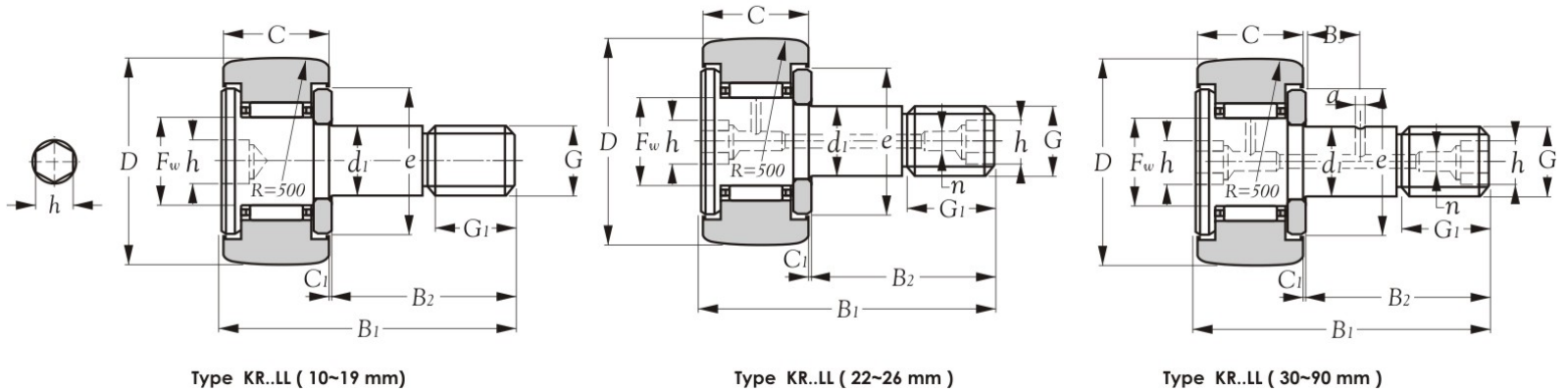

Items (18)	Data  Model nos.	Dimension			Packing method	Quantity  Min. order qty.	Delivery	2014-09-01			
		Bearing sizes						Unit price structure	Unit price structure	Compare percentages (%)	Production code(s)
		Fw	D	B1							
			mm			Pcs	Days	USD	USD		
1	<b>KR 10 LL (5x1)</b>	7	10	17	N2	-	-	-	-	-	-
2	<b>KR 12 LL (10x1)</b>	8	12	20	N2	-	-	-	-	-	-
3	<b>KR 13 LL (10x1)</b>	9	13	23	N2	100	90	-	<b>5.58</b>	-	YF
4	* <b>KR 16 LL</b>	11	16	28	N1	100	90	-	<b>3.66</b>	-	YF
5	* <b>KR 19 LL</b>	11	19	32	N1	90	90	-	<b>4.24</b>	-	YF
6	* <b>KR 22 LL</b>	12	22	36	N1	90	90	-	<b>4.45</b>	-	YF
7	* <b>KR 26 LL</b>	12	26	36	N1	70	90	-	<b>5.14</b>	-	YF
8	* <b>KR 30 LL</b>	14	30	40	N1	70	90	-	<b>5.61</b>	-	YF
9	* <b>KR 32 LL</b>	14	32	40	N1	60	90	-	<b>5.88</b>	-	YF
10	* <b>KR 35 LL</b>	18	35	52	N1	60	90	-	<b>6.98</b>	-	YF
11	* <b>KR 40 LL</b>	20	40	58	N1	45	90	-	<b>8.41</b>	-	YF
12	* <b>KR 47 LL</b>	24	47	66	N1	35	90	-	<b>10.10</b>	-	YF
13	* <b>KR 52 LL</b>	24	52	66	N1	35	90	-	<b>11.29</b>	-	YF
14	* <b>KR 62 LL</b>	29	62	80	N1	30	90	-	<b>13.30</b>	-	YF
15	* <b>KR 72 LL</b>	29	72	80	N1	30	90	-	<b>14.96</b>	-	YF
16	* <b>KR 80 LL</b>	35	80	100	N1	25	90	-	<b>20.26</b>	-	YF
17	<b>KR 85 LL</b>	35	85	100	N1	20	90	-	<b>22.31</b>	-	YF
18	* <b>KR 90 LL</b>	35	90	100	N1	15	90	-	<b>27.90</b>	-	YF

- Remark : 1. Production before May,2010, all the bearings have only one axial hole.  
 2. Production after May,2010, bearings which inner Dia. ≤19mm, have one axial hole; bearings which inner Dia. >19mm have 2 axial holes.  
 3. Production after Oct,2010, KR 47 LL, KR 52 LL matched with 2# Nipples.

<b>Remark</b>	Technical supplement		
	Cage(s)	Precision	Grease
	Steel - ✓	Class 0 (JIS)	Alvania S2 -25℃~+120℃
	Polymid - ✗		
Brass - ✗			

Qualified Sub-contractor(s)	Since
YF	2004
-	-
-	-

CAM FOLLOWERS STUD TYPE TRUCK ROLLERS

SERIES **KRV**

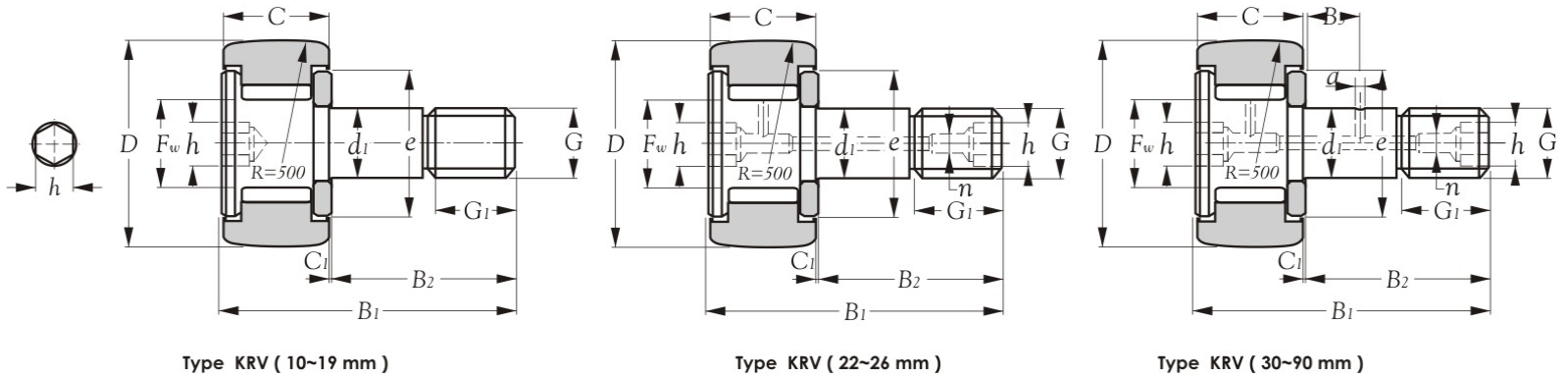

Items (17)	Data  Model nos.	Dimension			Packing method	Quantity  Min. order qty.	Delivery	-			
		Bearing sizes						Unit price structure	2014-09-01 Unit price structure	Compare percentages (%)	Production code(s)
		<i>F<sub>w</sub></i>	<i>D</i>	<i>B<sub>1</sub></i>							
mm			Pcs	Days	USD	USD					
1	<b>KRV 10 (5x1)</b>	-	-	-	N2	-	-	-	-	-	-
2	<b>KRV 12 (10x1)</b>	-	-	-	N2	-	-	-	-	-	-
3	<b>KRV 13 (10x1)</b>	9	13	23	N2	100	90	-	<b>5.53</b>	-	YF
4	<b>KRV 16</b>	11	16	28	N1	100	90	-	<b>3.70</b>	-	YF
5	<b>KRV 19</b>	11	19	32	N1	90	90	-	<b>4.33</b>	-	YF
6	<b>KRV 22</b>	12	22	36	N1	80	90	-	<b>4.48</b>	-	YF
7	<b>KRV 26</b>	12	26	36	N1	70	90	-	<b>5.26</b>	-	YF
8	<b>KRV 30</b>	14	30	40	N1	70	90	-	<b>5.40</b>	-	YF
9	<b>KRV 32</b>	14	32	40	N1	60	90	-	<b>5.94</b>	-	YF
10	<b>KRV 35</b>	18	35	52	N1	50	90	-	<b>7.06</b>	-	YF
11	<b>KRV 40</b>	20	40	58	N1	40	90	-	<b>9.54</b>	-	YF
12	<b>KRV 47</b>	24	47	66	N1	35	90	-	<b>10.26</b>	-	YF
13	<b>KRV 52</b>	24	52	66	N1	35	90	-	<b>11.45</b>	-	YF
14	<b>KRV 62</b>	29	62	80	N1	30	90	-	<b>13.48</b>	-	YF
15	<b>KRV 72</b>	29	72	80	N1	30	90	-	<b>15.18</b>	-	YF
16	<b>KRV 80</b>	35	80	100	N1	25	90	-	<b>18.51</b>	-	YF
17	<b>KRV 90</b>	35	90	100	N1	15	90	-	<b>27.23</b>	-	YF

- Remark : 1. Production before May,2010, all the bearings have only one axial hole.  
 2. Production after May,2010, bearings which inner Dia. ≤19mm, have one axial hole; bearings which inner Dia. >19mm have 2 axial holes.  
 3. Production after Oct,2010, KRV 47, KRV 52 matched with 2# Nipples.

Remark	Technical supplement		
	Cage(s)	Precision	Grease
	Steel - <input checked="" type="checkbox"/> Polymid - <input checked="" type="checkbox"/> Brass - <input checked="" type="checkbox"/>	Class 0 (JIS)	Alvania S2 -25℃~+120℃

Qualified Sub-contractor(s)	Since
YF	2004
-	-
-	-

**CAM FOLLOWERS STUD TYPE TRUCK ROLLERS**  
**SERIES KRV..LL**

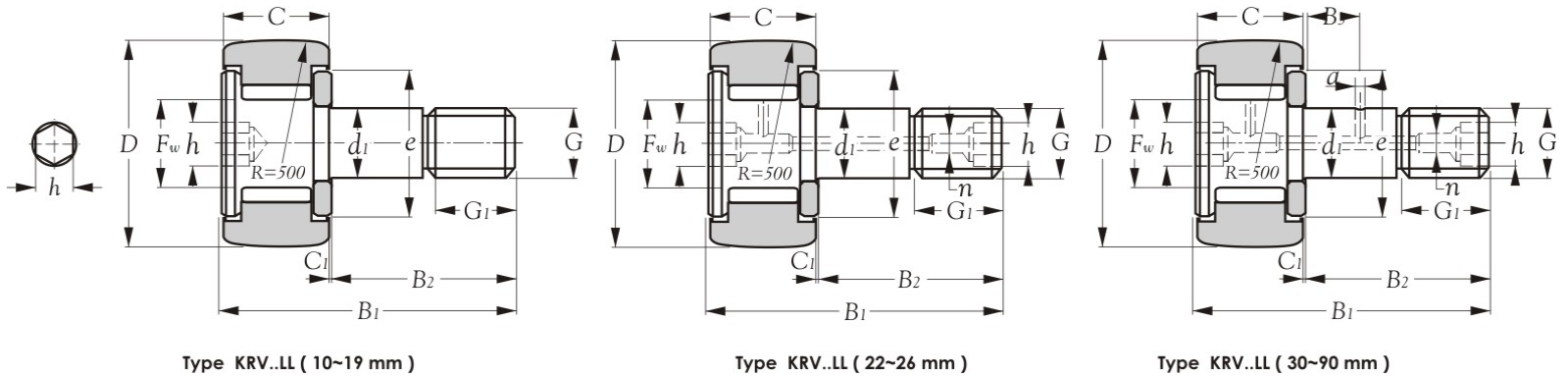

Items (17)	Data  Model nos.	Dimension			Packing method	Quantity  Min. order qty.	Delivery  Days	-	2014-09-01	Compare percentages (%)	Production code(s)		
		Bearing sizes										Unit price structure	Unit price structure
		Fw	D	B1									
		mm				Pcs		USD	USD				
1	<b>KRV 10 LL (5x1)</b>	7	10	17	N2	-	-	-	-	-	-		
2	<b>KRV 12 LL (10x1)</b>	8	12	20	N2	-	-	-	-	-	-		
3	<b>KRV 13 LL (10x1)</b>	9	13	23	N2	100	90	-	<b>5.79</b>	-	YF		
4	* <b>KRV 16 LL</b>	11	16	28	N1	100	90	-	<b>3.81</b>	-	YF		
5	* <b>KRV 19 LL</b>	11	19	32	N1	90	90	-	<b>4.40</b>	-	YF		
6	* <b>KRV 22 LL</b>	12	22	36	N1	80	90	-	<b>4.86</b>	-	YF		
7	* <b>KRV 26 LL</b>	12	26	36	N1	70	90	-	<b>5.33</b>	-	YF		
8	* <b>KRV 30 LL</b>	14	30	40	N1	70	90	-	<b>5.50</b>	-	YF		
9	* <b>KRV 32 LL</b>	14	32	40	N1	60	90	-	<b>6.13</b>	-	YF		
10	* <b>KRV 35 LL</b>	18	35	52	N1	50	90	-	<b>7.20</b>	-	YF		
11	* <b>KRV 40 LL</b>	20	40	58	N1	40	90	-	<b>9.65</b>	-	YF		
12	* <b>KRV 47 LL</b>	24	47	66	N1	35	90	-	<b>10.40</b>	-	YF		
13	* <b>KRV 52 LL</b>	24	52	66	N1	35	90	-	<b>11.60</b>	-	YF		
14	* <b>KRV 62 LL</b>	29	62	80	N1	30	90	-	<b>13.70</b>	-	YF		
15	* <b>KRV 72 LL</b>	29	72	80	N1	30	90	-	<b>15.54</b>	-	YF		
16	* <b>KRV 80 LL</b>	35	80	100	N1	25	90	-	<b>18.91</b>	-	YF		
17	* <b>KRV 90 LL</b>	35	90	100	N1	15	90	-	<b>27.90</b>	-	YF		

- Remark : 1. Production before May,2010, all the bearings have only one axial hole.  
 2. Production after May,2010, bearings which inner Dia. ≤19mm, have one axial hole; bearings which inner Dia. >19mm have 2 axial holes.  
 3. Production after Oct,2010, KRV 47 LL, KRV 52 LL matched with 2# Nipples.

Remark	Technical supplement		
	Cage(s)	Precision	Grease
	Steel - <input checked="" type="checkbox"/>	Class 0 (JIS)	Alvania S2 -25℃~+120℃
Polymid - <input checked="" type="checkbox"/>			
Brass - <input checked="" type="checkbox"/>			

Qualified Sub-contractor(s)	Since
YF	2004
-	-
-	-

**CAM FOLLOWERS STUD TYPE TRUCK ROLLERS (MULTI-ROW CYLINDRICAL ROLLER BEARINGS)**  
**SERIES NUKR**

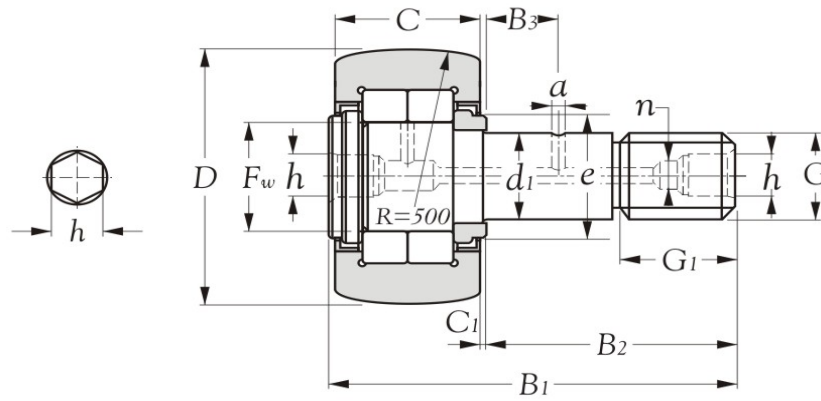

**Type NUKR ( D<100 mm ) ( Double row type full complement with seals )**

Items (8)	Data  Model nos.	Dimension			Packing method	Quantity  Min. order qty.  Pcs	Delivery  Days	-	2014-09-01	Compare percentages (%)	Production code(s)		
		Bearing sizes										Unit price structure  USD	Unit price structure  USD
		Fw	D	B1									
		mm											
1	* NUKR 35	35	18	52	N1	35	90	-	9.49	-	YF		
2	* NUKR 40	40	20	58	N1	30	90	-	11.95	-	YF		
3	* NUKR 47	47	24	66	N1	30	90	-	12.88	-	YF		
4	* NUKR 52	52	24	66	N1	25	90	-	15.26	-	YF		
5	* NUKR 62	62	29	80	N1	20	90	-	17.88	-	YF		
6	* NUKR 72	72	29	80	N1	20	90	-	20.88	-	YF		
7	* NUKR 80	80	35	100	N1	20	90	-	25.53	-	YF		
8	* NUKR 90	90	35	100	N1	15	90	-	30.01	-	YF		

- Remark : 1. Production before May,2010, all the bearings have only one axial hole.  
 2. Production after May,2010, bearings which inner Dia. ≤19mm, have one axial hole; bearings which inner Dia. >19mm have 2 axial holes.  
 3. Production after Oct,2010, NUKR 47, NUKR 52 matched with 2# Nipples.

Remark	Technical supplement		
	Cage(s)	Precision	Grease
	Steel - X	Class 0 (JIS)	Alvania S2 -25°C ~ +120°C
	Polymid - X		
	Brass - X		

Qualified Sub-contractor(s)	Since
YF	2004
-	-
-	-

**INNER RINGS**  
**SERIES IR**

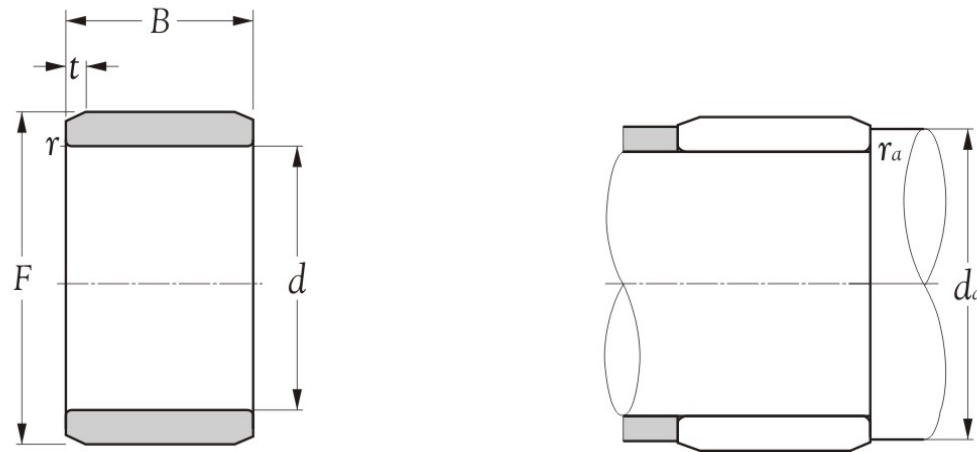

Items (20)	Data  Model nos.	Dimension			Packing method	Quantity  Min. order qty.  Pcs	Delivery  Days	-		Compare percentages (%)	Production code(s)
		Bearing sizes						Unit price structure	2014-09-01 Unit price structure		
		d	F	B							
		mm									
1	IR 5x7x10 (10x2)	5	7	10	N2	250	90	-	0.71	-	YF
2	* IR 5x8x12 (10x2)	5	8	12	N2	250	90	-	0.79	-	YF
3	IR 5x8x16 (10x2)	5	8	16	N2	250	90	-	0.89	-	YF
4	IR 6x8x10 (10x2)	6	8	10	N2	250	90	-	0.71	-	YF
5	* IR 6x9x12 (10x1)	6	9	12	N2	250	90	-	0.79	-	YF
6	IR 6x9x16 (10x1)	6	9	16	N2	190	90	-	0.94	-	YF
7	* IR 6x10x10 (10x1)	6	10	10	N2	250	90	-	0.76	-	YF
8	* IR 6x10x12 (5x1)	6	10	12	N2	250	90	-	0.76	-	YF
9	IR 6x10x13 (5x1)	6	10	13	N2	250	90	-	0.76	-	YF
10	IR 7x9x10 (10x1)	7	9	10	N2	250	90	-	0.74	-	YF
11	IR 7x10x10.5 (5x1)	7	10	10.5	N2	250	90	-	0.81	-	YF
12	IR 7x10x12 (5x1)	7	10	12	N2	250	90	-	0.81	-	YF
13	IR 7x10x16 (5x1)	7	10	16	N2	190	90	-	0.94	-	YF
14	IR 7x12x16 (10x2)	7	12	16	N2	190	90	-	1.03	-	YF
15	IR 8x10x11 (5x1)	8	10	11	N2	190	90	-	0.84	-	YF
16	* IR 8x12x10 (10x2)	8	12	10	N2	250	90	-	0.78	-	YF
17	* IR 8x12x10.5 (5x1)	8	12	10.5	N2	250	90	-	0.78	-	YF
18	IR 8x12x12 (10x2)	8	12	12	N2	250	90	-	0.81	-	YF
19	* IR 8x12x12.5 (10x2)	8	12	12.5	N2	250	90	-	0.81	-	YF
20	IR 8x14x16 (5x1)	8	14	16	N2	250	90	-	0.76	-	YF

Remark	Technical supplement		
	Cage(s)	Precision	Grease
	Steel - <input checked="" type="checkbox"/>	Class 0 (JIS)	Nil
	Polymid - <input checked="" type="checkbox"/>		
	Brass - <input checked="" type="checkbox"/>		

Qualified Sub-contractor(s)	Since
YF	2004
-	-
-	-

INNER RINGS

SERIES IR

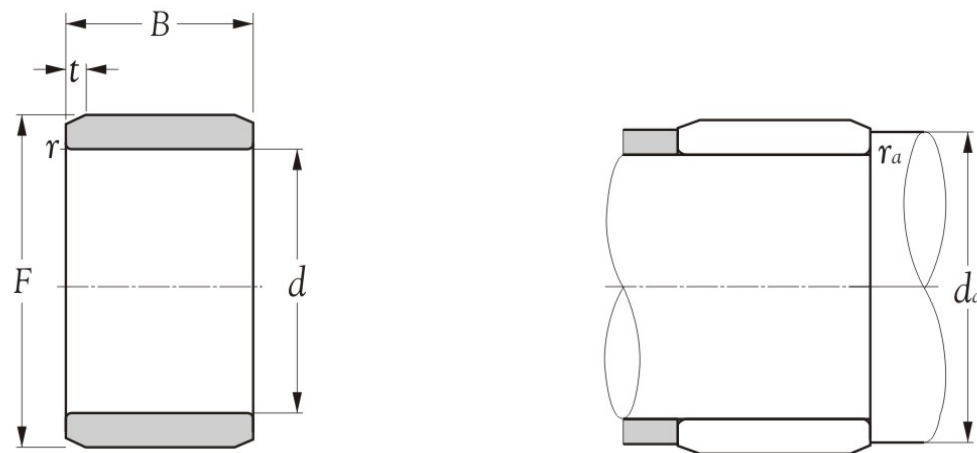

Items (20)	Data  Model nos.	Dimension			Packing method	Quantity  Min. order qty.  Pcs	Delivery  Days	-	2014-09-01	Compare percentages (%)	Production code(s)		
		Bearing sizes										Unit price structure  USD	Unit price structure  USD
		d	F	B									
		mm											
21	IR 9x12x11 (10x2)	9	12	11	N2	190	90	-	0.91	-	YF		
22	* IR 9x12x12 (10x2)	9	12	12	N2	190	90	-	0.91	-	YF		
23	* IR 9x12x16 (10x2)	9	12	16	N2	190	90	-	0.94	-	YF		
24	IR 9x15x16	9	15	16	N1	180	90	-	1.01	-	YF		
25	* IR 10x13x12.5 (5x1)	10	13	12.5	N2	250	90	-	0.78	-	YF		
26	* IR 10x14x12 (5x1)	10	14	12	N2	250	90	-	0.76	-	YF		
27	* IR 10x14x13 (5x1)	10	14	13	N2	250	90	-	0.76	-	YF		
28	* IR 10x14x14 (5x1)	10	14	14	N2	250	90	-	0.76	-	YF		
29	* IR 10x14x16 (5x1)	10	14	16	N2	250	90	-	0.81	-	YF		
30	* IR 10x14x20 (5x1)	10	14	20	N2	250	90	-	0.84	-	YF		
31	IR 10x15x15.5	10	15	15.5	N1	250	90	-	0.81	-	YF		
32	IR 10x15x20.5	10	15	20.5	N1	250	90	-	0.89	-	YF		
33	IR 10x16x16 (5x1)	10	16	16	N2	190	90	-	0.94	-	YF		
34	* IR 12x15x12	12	15	12	N1	250	90	-	0.76	-	YF		
35	* IR 12x15x12.5	12	15	12.5	N1	250	90	-	0.76	-	YF		
36	* IR 12x15x16	12	15	16	N1	250	90	-	0.78	-	YF		
37	* IR 12x15x16.5	12	15	16.5	N1	250	90	-	0.78	-	YF		
38	IR 12x15x22.5	12	15	22.5	N1	250	90	-	0.96	-	YF		
39	* IR 12x16x12 (5x1)	12	16	12	N2	300	90	-	0.66	-	YF		
40	* IR 12x16x13	12	16	13	N1	300	90	-	0.66	-	YF		

<b>Remark</b>	Technical supplement		
	Cage(s)	Precision	Grease
	Steel - <input checked="" type="checkbox"/>	Class 0 (JIS)	Nil
	Polymid - <input checked="" type="checkbox"/>		
Brass - <input checked="" type="checkbox"/>			

Qualified Sub-contractor(s)	Since
YF	2004
-	-
-	-

**INNER RINGS**  
**SERIES IR**

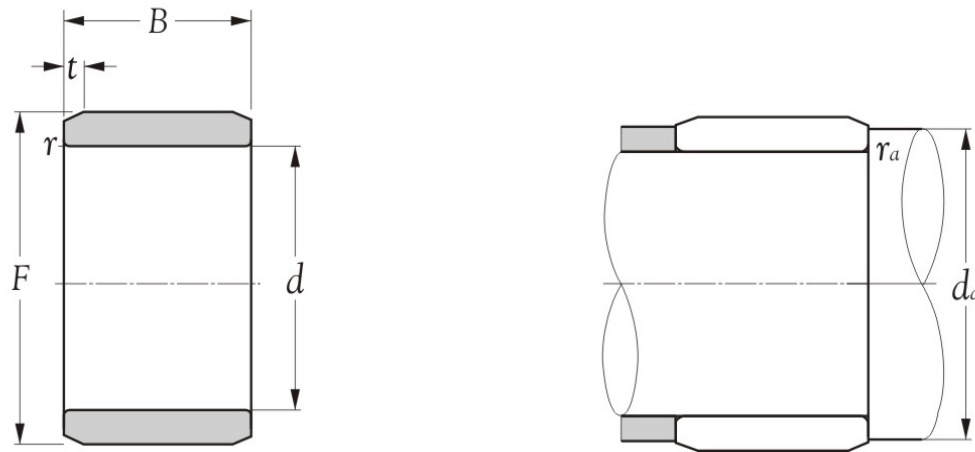

Items (20)	Data  Model nos.	Dimension			Packing method	Quantity  Min. order qty.  Pcs	Delivery  Days	Unit price structure  USD	2014-09-01 Unit price structure  USD	Compare percentages (%)	Production code(s)
		Bearing sizes									
		d	F	B							
		mm									
41	* IR 12x16x14 (5x1)	12	16	14	N2	300	90	-	0.66	-	YF
42	* IR 12x16x16	12	16	16	N1	300	90	-	0.69	-	YF
43	* IR 12x16x20	12	16	20	N1	250	90	-	0.79	-	YF
44	* IR 12x16x22	12	16	22	N1	250	90	-	0.88	-	YF
45	IR 12x17x20.5	12	17	20.5	N1	300	90	-	0.88	-	YF
46	IR 12x17x25.5	12	17	25.5	N1	300	90	-	1.14	-	YF
47	IR 12x18x16	12	18	16	N1	250	90	-	0.84	-	YF
48	* IR 14x17x17	14	17	17	N1	250	90	-	0.81	-	YF
49	* IR 15x18x12.5	15	18	12.5	N1	250	90	-	0.76	-	YF
50	* IR 15x18x16	15	18	16	N1	250	90	-	0.78	-	YF
51	* IR 15x18x16.5	15	18	16.5	N1	250	90	-	0.78	-	YF
52	IR 15x18x17.5	15	18	17.5	N1	250	90	-	0.78	-	YF
53	IR 15x18x20.5	15	18	20.5	N1	250	90	-	0.79	-	YF
54	IR 15x18x25.5	15	18	25.5	N1	250	90	-	0.89	-	YF
55	IR 15x19x16	15	19	16	N1	300	90	-	0.74	-	YF
56	* IR 15x19x20	15	19	20	N1	300	90	-	0.74	-	YF
57	* IR 15x20x12	15	20	12	N1	300	90	-	0.74	-	YF
58	* IR 15x20x13	15	20	13	N1	300	90	-	0.74	-	YF
59	* IR 15x20x14	15	20	14	N1	300	90	-	0.74	-	YF
60	IR 15x20x18	15	20	18	N1	250	90	-	0.78	-	YF

Remark	Technical supplement		
	Cage(s)	Precision	Grease
	Steel - <input checked="" type="checkbox"/>	Class 0 (JIS)	Nil
	Polymid - <input checked="" type="checkbox"/>		
	Brass - <input checked="" type="checkbox"/>		

Qualified Sub-contractor(s)	Since
YF	2004
-	-
-	-

**INNER RINGS**  
**SERIES IR**

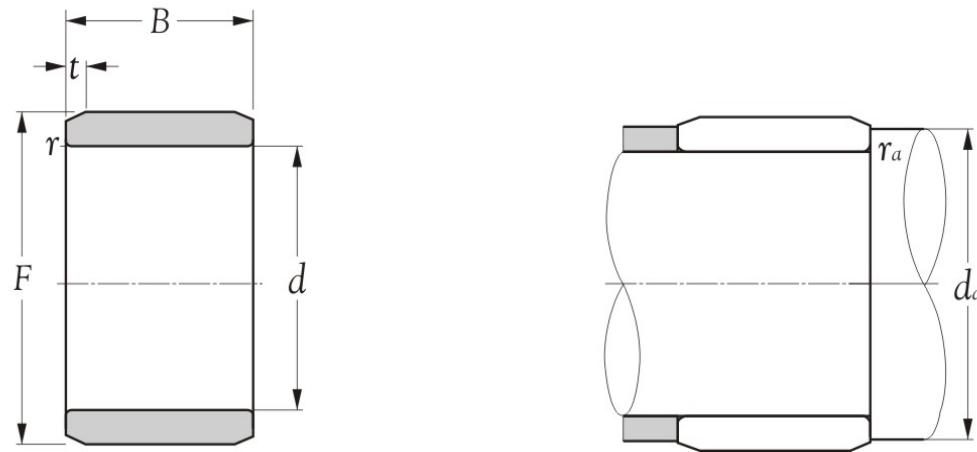

Items (20)	Data  Model nos.	Dimension			Packing method	Quantity  Min. order qty.  Pcs	Delivery  Days	-		Compare percentages (%)	Production code(s)
		Bearing sizes						Unit price structure	2014-09-01 Unit price structure		
		d	F	B							
		mm									
61	IR 15x20x20.5	15	20	20.5	N1	250	90	-	0.78	-	YF
62	* IR 15x20x23	15	20	23	N1	250	90	-	0.78	-	YF
63	IR 15x20x26	15	20	26	N1	250	90	-	0.81	-	YF
64	IR 15x20x30.5	15	20	30.5	N1	250	90	-	0.93	-	YF
65	IR 15x22x20	15	22	20	N1	250	90	-	0.88	-	YF
66	* IR 17x20x16	17	20	16	N1	190	90	-	0.94	-	YF
67	* IR 17x20x16.5	17	20	16.5	N1	190	90	-	0.94	-	YF
68	* IR 17x20x20	17	20	20	N1	190	90	-	0.94	-	YF
69	* IR 17x20x20.5	17	20	20.5	N1	190	90	-	0.94	-	YF
70	* IR 17x20x30.5	17	20	30.5	N1	180	90	-	0.93	-	YF
71	IR 17x21x16	17	21	16	N1	300	90	-	0.74	-	YF
72	IR 17x21x20	17	21	20	N1	300	90	-	0.78	-	YF
73	* IR 17x22x13	17	22	13	N1	250	90	-	0.78	-	YF
74	IR 17x22x14	17	22	14	N1	250	90	-	0.78	-	YF
75	* IR 17x22x16	17	22	16	N1	250	90	-	0.78	-	YF
76	IR 17x22x18	17	22	18	N1	250	90	-	0.81	-	YF
77	IR 17x22x20.5	17	22	20.5	N1	250	90	-	0.81	-	YF
78	* IR 17x22x23	17	22	23	N1	250	90	-	0.81	-	YF
79	IR 17x22x26	17	22	26	N1	250	90	-	0.81	-	YF
80	IR 17x22x32	17	22	32	N1	250	90	-	0.93	-	YF

Remark	Technical supplement		
	Cage(s)	Precision	Grease
	Steel - <input checked="" type="checkbox"/>	Class 0 (JIS)	Nil
	Polymid - <input checked="" type="checkbox"/>		
	Brass - <input checked="" type="checkbox"/>		

Qualified Sub-contractor(s)	Since
YF	2004
-	-
-	-



**INNER RINGS**  
**SERIES IR**

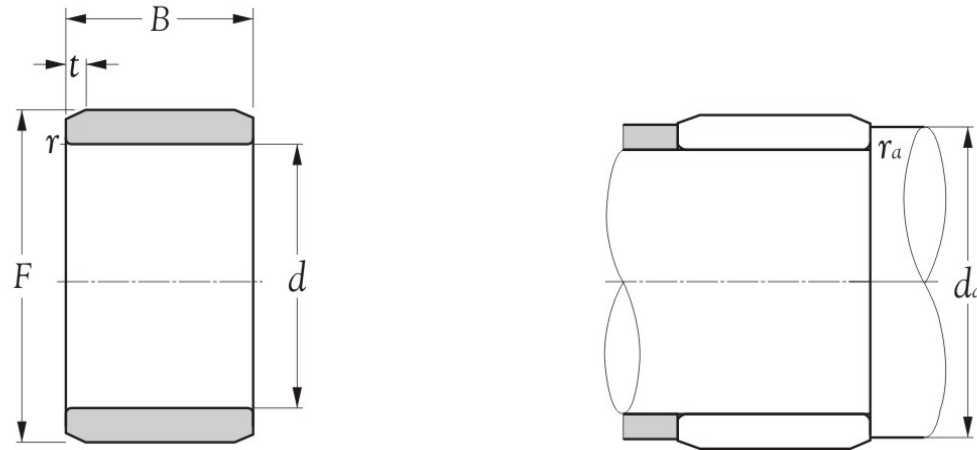

Items (20)	Data  Model nos.	Dimension			Packing method	Quantity  Min. order qty.  Pcs	Delivery  Days	-	2014-09-01	Compare percentages (%)	Production code(s)		
		Bearing sizes										Unit price structure  USD	Unit price structure  USD
		d	F	B									
		mm											
81	IR 17x24x20	17	24	20	N1	250	90	-	0.81	-	YF		
82	* IR 20x24x16	20	24	16	N1	300	90	-	0.78	-	YF		
83	* IR 20x24x20	20	24	20	N1	300	90	-	0.81	-	YF		
84	IR 20x24x28.5	20	24	28.5	N1	250	90	-	1.01	-	YF		
85	IR 20x25x12.5	20	25	12.5	N1	250	90	-	0.88	-	YF		
86	* IR 20x25x16	20	25	16	N1	250	90	-	0.88	-	YF		
87	IR 20x25x16.5	20	25	16.5	N1	250	90	-	0.88	-	YF		
88	* IR 20x25x17	20	25	17	N1	250	90	-	0.88	-	YF		
89	* IR 20x25x18	20	25	18	N1	250	90	-	0.88	-	YF		
90	* IR 20x25x20	20	25	20	N1	250	90	-	0.88	-	YF		
91	* IR 20x25x20.5	20	25	20.5	N1	250	90	-	0.88	-	YF		
92	IR 20x25x23	20	25	23	N1	190	90	-	0.99	-	YF		
93	IR 20x25x26	20	25	26	N1	190	90	-	1.03	-	YF		
94	* IR 20x25x26.5	20	25	26.5	N1	190	90	-	1.03	-	YF		
95	* IR 20x25x30	20	25	30	N1	190	90	-	1.03	-	YF		
96	IR 20x25x32	20	25	32	N1	190	90	-	1.03	-	YF		
97	* IR 20x25x38.5	20	25	38.5	N1	190	90	-	1.18	-	YF		
98	IR 20x28x20	20	28	20	N1	190	90	-	1.03	-	YF		
99	* IR 22x26x16	22	26	16	N1	250	90	-	0.88	-	YF		
100	* IR 22x26x20	22	26	20	N1	250	90	-	0.89	-	YF		

<b>Remark</b>	Technical supplement		
	Cage(s)	Precision	Grease
	Steel - <input checked="" type="checkbox"/>	Class 0 (JIS)	Nil
	Polymid - <input checked="" type="checkbox"/>		
Brass - <input checked="" type="checkbox"/>			

Qualified Sub-contractor(s)	Since
YF	2004
-	-
-	-

**INNER RINGS**  
**SERIES IR**

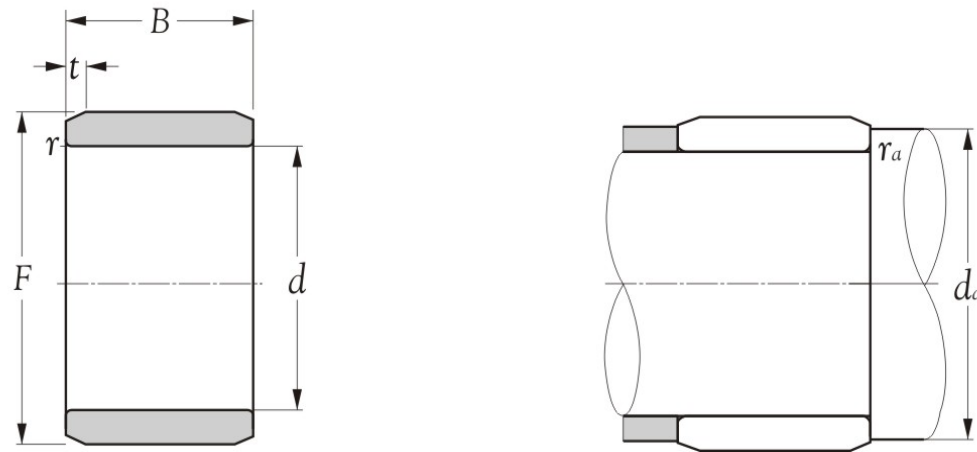

Items (20)	Data  Model nos.	Dimension			Packing method	Quantity  Min. order qty.  Pcs	Delivery  Days	-  Unit price structure  USD	2014-09-01  Unit price structure  USD	Compare percentages (%)	Production code(s)
		Bearing sizes									
		d	F	B							
		mm									
101	* IR 22x28x17	22	28	17	N1	190	90	-	1.03	-	YF
102	* IR 22x28x20	22	28	20	N1	190	90	-	1.03	-	YF
103	IR 22x28x20.5	22	28	20.5	N1	190	90	-	1.03	-	YF
104	IR 22x28x23	22	28	23	N1	190	90	-	1.03	-	YF
105	* IR 22x28x30	22	28	30	N1	170	90	-	1.14	-	YF
106	* IR 25x29x20	25	29	20	N1	190	90	-	1.03	-	YF
107	* IR 25x29x30	25	29	30	N1	190	90	-	1.05	-	YF
108	IR 25x30x12.5	25	30	12.5	N1	190	90	-	1.03	-	YF
109	* IR 25x30x16	25	30	16	N1	190	90	-	1.03	-	YF
110	IR 25x30x16.5	25	30	16.5	N1	190	90	-	1.03	-	YF
111	* IR 25x30x17	25	30	17	N1	190	90	-	1.03	-	YF
112	* IR 25x30x18	25	30	18	N1	190	90	-	1.03	-	YF
113	* IR 25x30x20	25	30	20	N1	190	90	-	1.03	-	YF
114	* IR 25x30x20.5	25	30	20.5	N1	190	90	-	1.03	-	YF
115	IR 25x30x23	25	30	23	N1	180	90	-	1.10	-	YF
116	IR 25x30x26	25	30	26	N1	180	90	-	1.10	-	YF
117	* IR 25x30x26.5	25	30	26.5	N1	180	90	-	1.10	-	YF
118	* IR 25x30x30	25	30	30	N1	180	90	-	1.10	-	YF
119	IR 25x30x32	25	30	32	N1	180	90	-	1.10	-	YF
120	* IR 25x30x38.5	25	30	38.5	N1	150	90	-	1.34	-	YF

Remark	Technical supplement		
	Cage(s)	Precision	Grease
	Steel - <input checked="" type="checkbox"/>	Class 0 (JIS)	Nil
	Polymid - <input checked="" type="checkbox"/>		
	Brass - <input checked="" type="checkbox"/>		

Qualified Sub-contractor(s)	Since
YF	2004
-	-
-	-

**INNER RINGS**  
**SERIES IR**

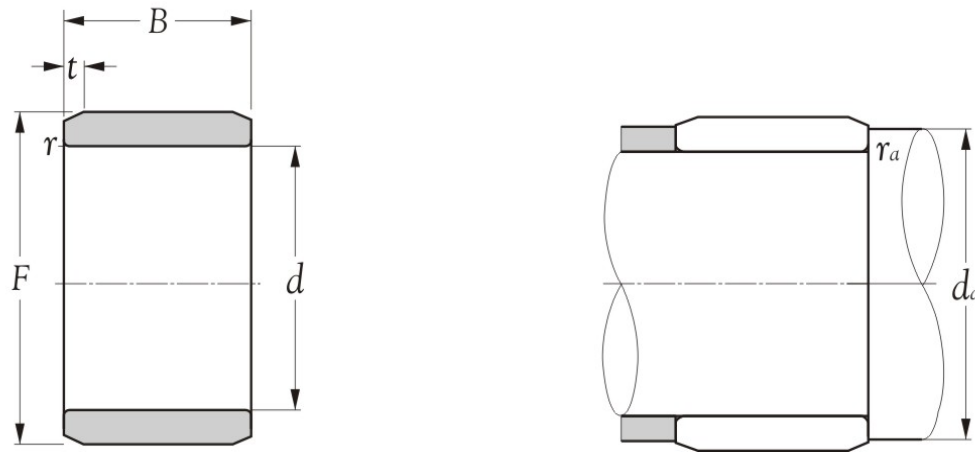

Items (20)	Data  Model nos.	Dimension			Packing method	Quantity  Min. order qty.  Pcs	Delivery  Days	Unit price structure  USD	2014-09-01 Unit price structure  USD	Compare percentages (%)	Production code(s)
		Bearing sizes									
		d	F	B							
		mm									
121	IR 25x32x22	25	32	22	N1	170	90	-	1.14	-	YF
122	IR 25x32x30.5	25	32	30.5	N1	150	90	-	1.34	-	YF
123	IR 28x32x17	28	32	17	N1	170	90	-	1.10	-	YF
124	* IR 28x32x20	28	32	20	N1	170	90	-	1.14	-	YF
125	IR 28x32x23	28	32	23	N1	170	90	-	1.14	-	YF
126	IR 28x32x30	28	32	30	N1	140	90	-	1.33	-	YF
127	IR 29x32x13	29	32	13	N1	170	90	-	1.13	-	YF
128	IR 30x35x12.5	30	35	12.5	N1	250	90	-	1.03	-	YF
129	IR 30x35x13	30	35	13	N1	250	90	-	1.03	-	YF
130	* IR 30x35x16	30	35	16	N1	250	90	-	1.03	-	YF
131	IR 30x35x16.5	30	35	16.5	N1	250	90	-	1.03	-	YF
132	* IR 30x35x17	30	35	17	N1	250	90	-	1.03	-	YF
133	* IR 30x35x18	30	35	18	N1	250	90	-	1.03	-	YF
134	* IR 30x35x20	30	35	20	N1	180	90	-	1.10	-	YF
135	* IR 30x35x20.5	30	35	20.5	N1	180	90	-	1.10	-	YF
136	IR 30x35x23	30	35	23	N1	180	90	-	1.10	-	YF
137	* IR 30x35x26	30	35	26	N1	170	90	-	1.14	-	YF
138	* IR 30x35x30	30	35	30	N1	150	90	-	1.34	-	YF
139	IR 30x35x32	30	35	32	N1	150	90	-	1.34	-	YF
140	* IR 30x37x18	30	37	18	N1	180	90	-	1.10	-	YF

<b>Remark</b>	Technical supplement		
	Cage(s)	Precision	Grease
	Steel - <input checked="" type="checkbox"/>	Class 0 (JIS)	Nil
	Polymid - <input checked="" type="checkbox"/>		
Brass - <input checked="" type="checkbox"/>			

Qualified Sub-contractor(s)	Since
YF	2004
-	-
-	-

**INNER RINGS**  
**SERIES IR**

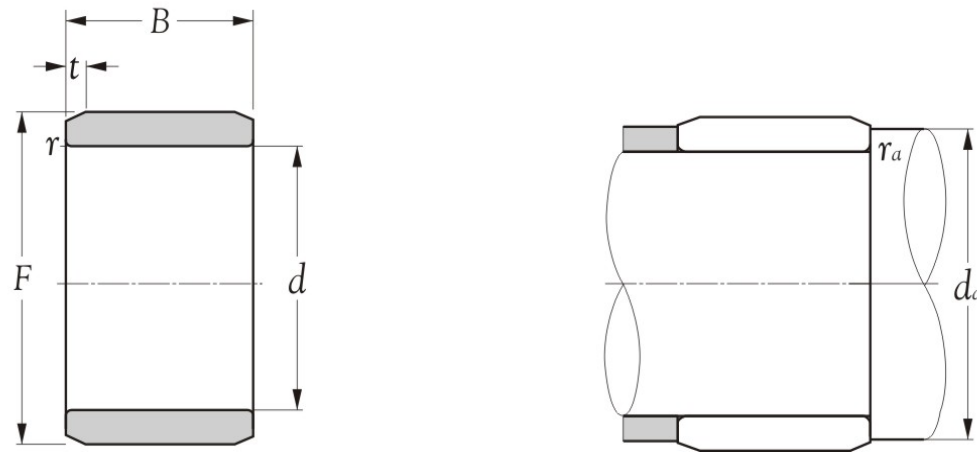

Items (20)	Data  Model nos.	Dimension			Packing method	Quantity  Min. order qty.  Pcs	Delivery  Days	-	2014-09-01	Compare percentages (%)	Production code(s)		
		Bearing sizes										Unit price structure  USD	Unit price structure  USD
		d	F	B									
		mm											
141	IR 30x37x22	30	37	22	N1	180	90	-	1.10	-	YF		
142	IR 30x38x20	30	38	20	N1	160	90	-	1.28	-	YF		
143	IR 32x37x20	32	37	20	N1	160	90	-	1.28	-	YF		
144	* IR 32x37x30	32	37	30	N1	160	90	-	1.28	-	YF		
145	IR 32x38x32	32	38	32	N1	160	90	-	1.28	-	YF		
146	* IR 32x40x20	32	40	20	N1	160	90	-	1.28	-	YF		
147	IR 32x40x27	32	40	27	N1	140	90	-	1.40	-	YF		
148	IR 32x40x36	32	40	36	N1	140	90	-	1.45	-	YF		
149	IR 33x37x13	33	37	13	N1	140	90	-	1.38	-	YF		
150	* IR 35x40x12.5	35	40	12.5	N1	190	90	-	1.05	-	YF		
151	IR 35x40x16.5	35	40	16.5	N1	190	90	-	1.05	-	YF		
152	IR 35x40x17	35	40	17	N1	190	90	-	1.05	-	YF		
153	IR 35x40x20	35	40	20	N1	190	90	-	1.10	-	YF		
154	IR 35x40x20.5	35	40	20.5	N1	190	90	-	1.10	-	YF		
155	* IR 35x40x30	35	40	30	N1	170	90	-	1.33	-	YF		
156	IR 35x40x34	35	40	34	N1	160	90	-	1.33	-	YF		
157	IR 35x40x40	35	40	40	N1	150	90	-	1.44	-	YF		
158	IR 35x42x20	35	42	20	N1	150	90	-	1.51	-	YF		
159	* IR 35x42x21	35	42	21	N1	150	90	-	1.30	-	YF		
160	IR 35x42x23	35	42	23	N1	150	90	-	1.59	-	YF		

<b>Remark</b>	Technical supplement		
	Cage(s)	Precision	Grease
	Steel - <input checked="" type="checkbox"/>	Class 0 (JIS)	Nil
	Polymid - <input checked="" type="checkbox"/>		
Brass - <input checked="" type="checkbox"/>			

Qualified Sub-contractor(s)	Since
YF	2004
-	-
-	-

**INNER RINGS**  
**SERIES IR**

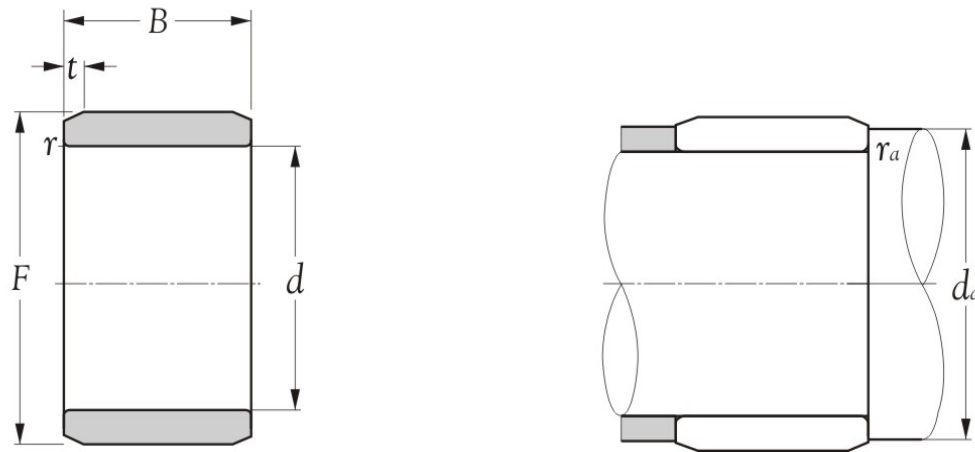

Items (20)	Data  Model nos.	Dimension			Packing method	Quantity  Min. order qty.  Pcs	Delivery  Days	-	2014-09-01	Compare percentages (%)	Production code(s)		
		Bearing sizes										Unit price structure  USD	Unit price structure  USD
		d	F	B									
		mm											
161	IR 35x42x27	35	42	27	N1	170	90	-	1.61	-	YF		
162	* IR 35x42x36	35	42	36	N1	170	90	-	1.61	-	YF		
163	IR 35x43x22	35	43	22	N1	170	90	-	1.51	-	YF		
164	* IR 38x43x20	38	43	20	N1	170	90	-	1.14	-	YF		
165	IR 38x43x30	38	43	30	N1	150	90	-	1.34	-	YF		
166	IR 40x45x16.5	40	45	16.5	N1	160	90	-	1.28	-	YF		
167	* IR 40x45x17	40	45	17	N1	160	90	-	1.28	-	YF		
168	* IR 40x45x20	40	45	20	N1	150	90	-	1.34	-	YF		
169	* IR 40x45x20.5	40	45	20.5	N1	150	90	-	1.34	-	YF		
170	IR 40x45x26.5	40	45	26.5	N1	150	90	-	1.34	-	YF		
171	* IR 40x45x30	40	45	30	N1	150	90	-	1.44	-	YF		
172	IR 40x45x34	40	45	34	N1	140	90	-	1.59	-	YF		
173	IR 40x45x40	40	45	40	N1	140	90	-	1.84	-	YF		
174	IR 40x48x22	40	48	22	N1	140	90	-	1.40	-	YF		
175	* IR 40x48x23	40	48	23	N1	140	90	-	1.40	-	YF		
176	IR 40x48x30	40	48	30	N1	140	90	-	1.59	-	YF		
177	* IR 40x48x40	40	48	40	N1	130	90	-	1.84	-	YF		
178	* IR 40x48x20	40	50	20	N1	140	90	-	1.59	-	YF		
179	* IR 40x50x22	40	50	22	N1	140	90	-	1.59	-	YF		
180	* IR 42x47x20	42	47	20	N1	130	90	-	1.49	-	YF		

<b>Remark</b>	Technical supplement		
	Cage(s)	Precision	Grease
	Steel - <input checked="" type="checkbox"/>	Class 0 (JIS)	Nil
	Polymid - <input checked="" type="checkbox"/>		
Brass - <input checked="" type="checkbox"/>			

Qualified Sub-contractor(s)	Since
YF	2004
-	-
-	-

**INNER RINGS**  
**SERIES IR**

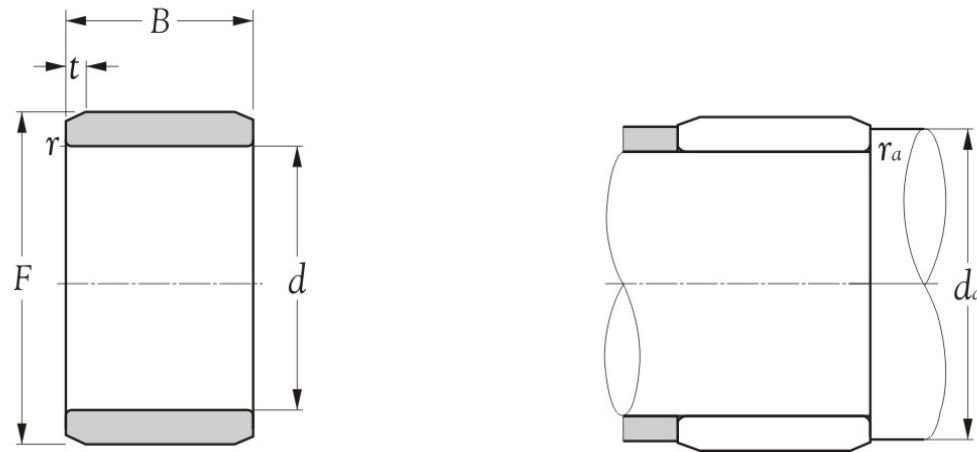

Items (20)	Data  Model nos.	Dimension			Packing method	Quantity  Min. order qty.	Delivery  Days	Unit price structure  USD	2014-09-01 Unit price structure  USD	Compare percentages (%)	Production code(s)
		Bearing sizes									
		d	F	B							
		mm				Pcs					
181	IR 42x47x30	42	47	30	N1	-	90	-	2.20	-	YF
182	* IR 45x50x20	45	50	20	N1	140	90	-	1.45	-	YF
183	* IR 45x50x25	45	50	25	N1	140	90	-	1.59	-	YF
184	IR 45x50x25.5	45	50	25.5	N1	140	90	-	1.59	-	YF
185	IR 45x50x32	45	50	32	N1	110	90	-	1.74	-	YF
186	IR 45x50x35	45	50	35	N1	100	90	-	1.93	-	YF
187	* IR 45x50x40	45	50	40	N1	90	90	-	2.33	-	YF
188	IR 45x52x22	45	52	22	N1	90	90	-	2.05	-	YF
189	IR 45x52x23	45	52	23	N1	90	90	-	2.05	-	YF
190	IR 45x52x30	45	52	30	N1	90	90	-	2.20	-	YF
191	IR 45x52x40	45	52	40	N1	90	90	-	2.56	-	YF
192	IR 45x55x20	45	55	20	N1	110	90	-	2.56	-	YF
193	IR 45x55x22	45	55	22	N1	110	90	-	2.38	-	YF
194	IR 45x55x40	45	55	40	N1	90	90	-	2.89	-	YF
195	* IR 50x55x20	50	55	20	N1	120	90	-	1.98	-	YF
196	* IR 50x55x25	50	55	25	N1	120	90	-	2.10	-	YF
197	* IR 50x55x35	50	55	35	N1	110	90	-	2.23	-	YF
198	* IR 50x55x40	50	55	40	N1	100	90	-	2.36	-	YF
199	IR 50x58x22	50	58	22	N1	110	90	-	2.10	-	YF
200	IR 50x58x23	50	58	23	N1	110	90	-	2.10	-	YF

<b>Remark</b>	Technical supplement		
	Cage(s)	Precision	Grease
	Steel - <input checked="" type="checkbox"/>	Class 0 (JIS)	Nil
	Polymid - <input checked="" type="checkbox"/>		
Brass - <input checked="" type="checkbox"/>			

Qualified Sub-contractor(s)	Since
YF	2004
-	-
-	-

**INNER RINGS**  
**SERIES IR**

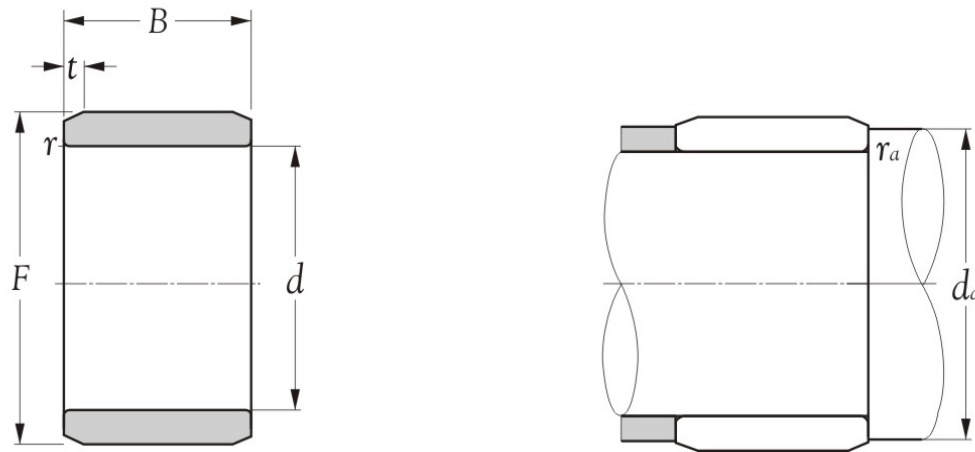

Items (20)	Data  Model nos.	Dimension			Packing method	Quantity  Min. order qty.  Pcs	Delivery  Days	Unit price structure  USD	2014-09-01	Compare percentages (%)	Production code(s)
		Bearing sizes							Unit price structure		
		d	F	B					USD		
		mm							USD		
201	IR 50x58x30	50	58	30	N1	100	90	-	2.23	-	YF
202	* IR 50x58x40	50	58	40	N1	100	90	-	2.63	-	YF
203	* IR 50x60x20	50	60	20	N1	100	90	-	2.23	-	YF
204	* IR 50x60x25	50	60	25	N1	100	90	-	3.08	-	YF
205	IR 50x60x28	50	60	28	N1	100	90	-	3.25	-	YF
206	IR 50x60x40	50	60	40	N1	100	90	-	4.44	-	YF
207	* IR 55x60x25	55	60	25	N1	80	90	-	2.66	-	YF
208	* IR 55x60x35	55	60	35	N1	60	90	-	2.95	-	YF
209	IR 55x63x25	55	63	25	N1	60	90	-	2.89	-	YF
210	IR 55x63x34	55	63	34	N1	60	90	-	3.25	-	YF
211	IR 55x63x45	55	63	45	N1	60	90	-	4.44	-	YF
212	IR 55x65x28	55	65	28	N1	60	90	-	3.40	-	YF
213	IR 55x65x30	55	65	30	N1	70	90	-	3.15	-	YF
214	IR 55x65x60	55	65	60	N1	50	90	-	10.21	-	YF
215	* IR 60x68x25	60	68	25	N1	60	90	-	3.08	-	YF
216	IR 60x68x34	60	68	34	N1	60	90	-	3.40	-	YF
217	IR 60x68x35	60	68	35	N1	60	90	-	3.40	-	YF
218	* IR 60x68x45	60	68	45	N1	60	90	-	4.79	-	YF
219	* IR 60x70x25	60	70	25	N1	60	90	-	3.40	-	YF
220	* IR 60x70x28	60	70	28	N1	60	90	-	3.36	-	YF

<b>Remark</b>	Technical supplement		
	Cage(s)	Precision	Grease
	Steel - <input checked="" type="checkbox"/>	Class 0 (JIS)	Nil
	Polymid - <input checked="" type="checkbox"/>		
Brass - <input checked="" type="checkbox"/>			

Qualified Sub-contractor(s)	Since
YF	2004
-	-
-	-

**INNER RINGS**  
**SERIES IR**

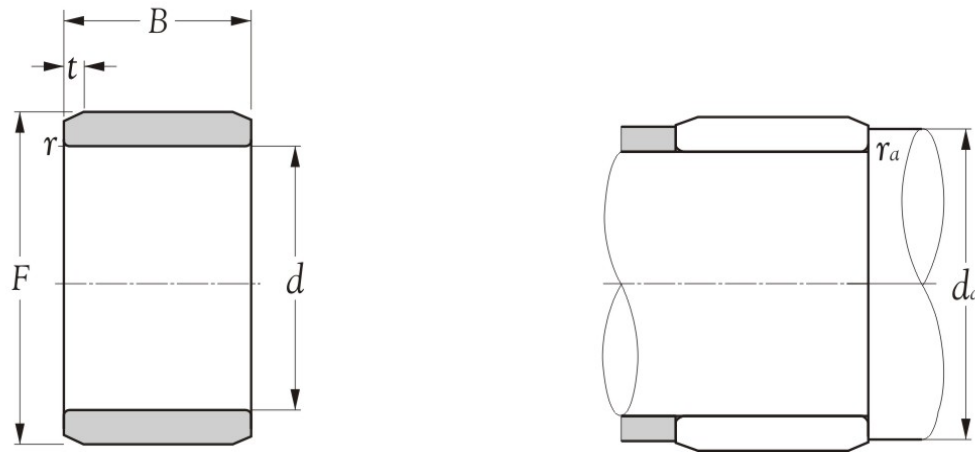

Items (20)	Data  Model nos.	Dimension			Packing method	Quantity  Min. order qty.  Pcs	Delivery  Days	-	2014-09-01	Compare percentages (%)	Production code(s)		
		Bearing sizes										Unit price structure  USD	Unit price structure  USD
		d	F	B									
		mm											
221	IR 60x70x30	60	70	30	N1	60	90	-	3.53	-	YF		
222	IR 60x70x60	60	70	60	N1	50	90	-	11.90	-	YF		
223	IR 65x72x25	65	72	25	N1	60	90	-	3.40	-	YF		
224	IR 65x72x34	65	72	34	N1	60	90	-	4.08	-	YF		
225	IR 65x72x45	65	72	45	N1	60	90	-	5.10	-	YF		
226	IR 65x73x25	65	73	25	N1	60	90	-	3.53	-	YF		
227	IR 65x73x35	65	73	35	N1	60	90	-	3.78	-	YF		
228	IR 65x75x28	65	75	28	N1	60	90	-	3.53	-	YF		
229	IR 65x75x30	65	75	30	N1	60	90	-	4.44	-	YF		
230	IR 65x75x60	65	75	60	N1	50	90	-	13.61	-	YF		
231	IR 70x80x25	70	80	25	N1	60	90	-	4.08	-	YF		
232	IR 70x80x28	70	80	28	N1	60	90	-	4.44	-	YF		
233	IR 70x80x30	70	80	30	N1	45	90	-	4.69	-	YF		
234	IR 70x80x35	70	80	35	N1	45	90	-	5.46	-	YF		
235	IR 70x80x40	70	80	40	N1	45	90	-	6.45	-	YF		
236	IR 70x80x54	70	80	54	N1	30	90	-	8.86	-	YF		
237	IR 70x80x56	70	80	56	N1	30	90	-	10.21	-	YF		
238	IR 70x80x60	70	80	60	N1	25	90	-	11.76	-	YF		
239	IR 75x85x25	75	85	25	N1	60	90	-	4.44	-	YF		
240	IR 75x85x30	75	85	30	N1	60	90	-	5.10	-	YF		

Remark	Technical supplement		
	Cage(s)	Precision	Grease
	Steel - <input checked="" type="checkbox"/>	Class 0 (JIS)	Nil
	Polymid - <input checked="" type="checkbox"/>		
	Brass - <input checked="" type="checkbox"/>		

Qualified Sub-contractor(s)	Since
YF	2004
-	-
-	-



**INNER RINGS**  
**SERIES IR**

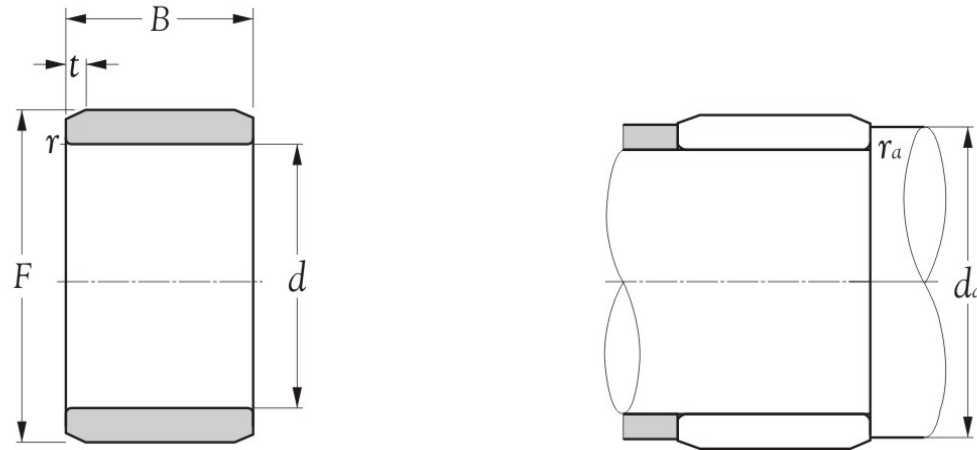

Items (20)	Data  Model nos.	Dimension			Packing method	Quantity  Min. order qty.  Pcs	Delivery  Days	-		Compare percentages (%)	Production code(s)
		Bearing sizes						Unit price structure	2014-09-01 Unit price structure		
		d	F	B							
		mm									
241	IR 75x85x35	75	85	35	N1	60	90	-	5.79	-	YF
242	IR 75x85x40	75	85	40	N1	60	90	-	7.15	-	YF
243	IR 75x85x54	75	85	54	N1	60	90	-	9.89	-	YF
244	IR 75x90x32	75	90	32	N1	60	90	-	8.51	-	YF
245	IR 80x90x25	80	90	25	N1	60	90	-	5.10	-	YF
246	IR 80x90x30	80	90	30	N1	35	90	-	5.79	-	YF
247	IR 80x90x35	80	90	35	N1	35	90	-	6.13	-	YF
248	IR 80x90x40	80	90	40	N1	30	90	-	6.39	-	YF
249	IR 80x90x54	80	90	54	N1	30	90	-	7.85	-	YF
250	IR 80x95x32	80	95	32	N1	30	90	-	9.18	-	YF
251	IR 85x95x26	85	95	26	N1	30	90	-	6.28	-	YF
252	IR 85x95x30	85	95	30	N1	30	90	-	7.06	-	YF
253	IR 85x95x36	85	95	36	N1	30	90	-	8.25	-	YF
254	IR 85x100x32	85	100	32	N1	30	90	-	11.76	-	YF
255	IR 85x100x35	85	100	35	N1	30	90	-	12.99	-	YF
256	IR 85x100x46	85	100	46	N1	30	90	-	15.71	-	YF
257	IR 85x100x63	85	100	63	N1	30	90	-	21.59	-	YF
258	IR 90x100x26	90	100	26	N1	30	90	-	7.06	-	YF
259	IR 90x100x30	90	100	30	N1	30	90	-	7.85	-	YF
260	IR 90x100x36	90	100	36	N1	30	90	-	9.03	-	YF

<b>Remark</b>	Technical supplement		
	Cage(s)	Precision	Grease
	Steel - <input checked="" type="checkbox"/>	Class 0 (JIS)	Nil
	Polymid - <input checked="" type="checkbox"/>		
Brass - <input checked="" type="checkbox"/>			

Qualified Sub-contractor(s)	Since
YF	2004
-	-
-	-

**INNER RINGS**  
**SERIES IR**

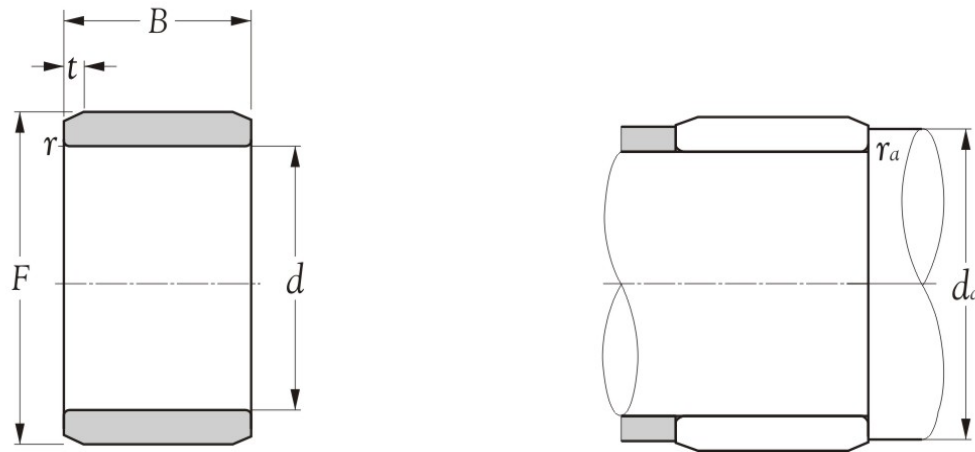

Items (20)	Data  Model nos.	Dimension			Packing method	Quantity  Min. order qty.  Pcs	Delivery  Days	-	2014-09-01	Compare percentages (%)	Production code(s)		
		Bearing sizes										Unit price structure  USD	Unit price structure  USD
		d	F	B									
		mm											
261	<b>IR 90x105x32</b>	90	105	32	N1	30	90	-	<b>12.99</b>	-	YF		
262	<b>IR 90x105x35</b>	90	105	35	N1	30	90	-	<b>13.73</b>	-	YF		
263	<b>IR 90x105x46</b>	90	105	46	N1	30	90	-	<b>17.68</b>	-	YF		
264	<b>IR 90x105x63</b>	90	105	63	N1	30	90	-	<b>23.71</b>	-	YF		
265	<b>IR 95x105x26</b>	95	105	26	N1	30	90	-	<b>7.85</b>	-	YF		
266	<b>IR 95x105x36</b>	95	105	36	N1	30	90	-	<b>9.81</b>	-	YF		
267	<b>IR 95x110x32</b>	95	110	32	N1	30	90	-	<b>13.73</b>	-	YF		
268	<b>IR 95x110x35</b>	95	110	35	N1	30	90	-	<b>14.54</b>	-	YF		
269	<b>IR 95x110x46</b>	95	110	46	N1	30	90	-	<b>17.68</b>	-	YF		
270	<b>IR 95x110x63</b>	95	110	63	N1	30	90	-	<b>23.56</b>	-	YF		
271	<b>IR 100x110x30</b>	100	110	30	N1	30	90	-	<b>9.81</b>	-	YF		
272	<b>IR 100x110x40</b>	100	110	40	N1	30	90	-	<b>11.76</b>	-	YF		
273	<b>IR 100x115x32</b>	100	115	32	N1	30	90	-	<b>14.90</b>	-	YF		
274	<b>IR 100x115x40</b>	100	115	40	N1	30	90	-	<b>16.49</b>	-	YF		
275	<b>IR 100x115x54</b>	100	115	54	N1	30	90	-	<b>22.00</b>	-	YF		
276	<b>IR 110x120x30</b>	110	120	30	N1	30	90	-	<b>11.76</b>	-	YF		
277	<b>IR 110x120x40</b>	110	120	40	N1	30	90	-	<b>13.73</b>	-	YF		
278	<b>IR 110x125x40</b>	110	125	40	N1	30	90	-	<b>17.68</b>	-	YF		
279	<b>IR 110x125x54</b>	110	125	54	N1	30	90	-	<b>21.59</b>	-	YF		
280	<b>IR 120x130x30</b>	120	130	30	N1	30	90	-	<b>13.73</b>	-	YF		

<b>Remark</b>	Technical supplement		
	Cage(s)	Precision	Grease
	Steel - <input checked="" type="checkbox"/>	Class 0 (JIS)	Nil
	Polymid - <input checked="" type="checkbox"/>		
Brass - <input checked="" type="checkbox"/>			

Qualified Sub-contractor(s)	Since
YF	2004
-	-
-	-

**INNER RINGS**  
**SERIES IR**

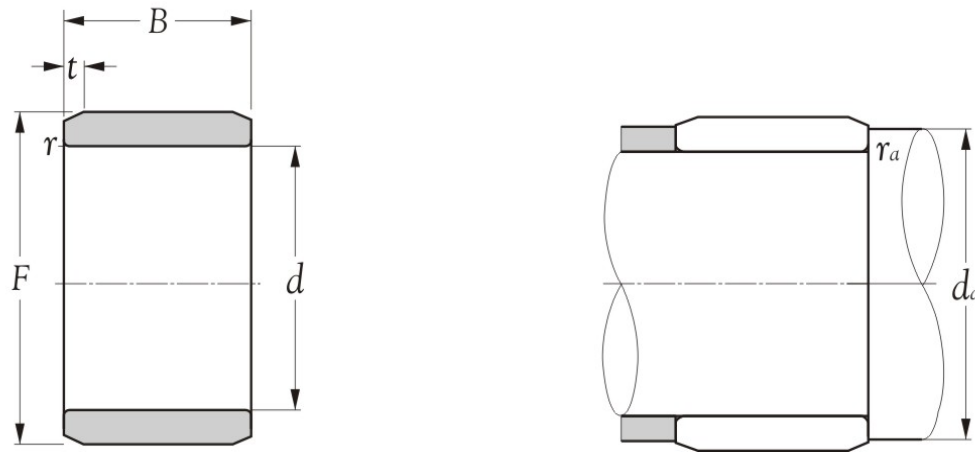

Items (20)	Data  Model nos.	Dimension			Packing method	Quantity  Min. order qty.  Pcs	Delivery  Days	-		Compare percentages (%)	Production code(s)
		Bearing sizes						Unit price structure	Unit price structure		
		d	F	B							
mm			USD	USD							
281	IR 120x130x40	120	130	40	N1	20	90	-	15.71	-	YF
282	IR 120x135x40	120	135	40	N1	20	90	-	19.61	-	YF
283	IR 120x135x45	120	135	45	N1	20	90	-	23.56	-	YF
284	IR 120x135x60	120	135	60	N1	20	90	-	30.63	-	YF
285	IR 130x145x32	130	145	32	N1	20	90	-	19.61	-	YF
286	IR 130x145x35	130	145	35	N1	20	90	-	21.59	-	YF
287	IR 130x145x42	130	145	42	N1	20	90	-	25.53	-	YF
288	IR 130x150x50	130	150	50	N1	20	90	-	33.38	-	YF
289	IR 130x150x52	130	150	52	N1	20	90	-	34.55	-	YF
290	IR 130x150x67	130	150	67	N1	20	90	-	45.16	-	YF
291	IR 140x155x32	140	155	32	N1	20	90	-	23.56	-	YF
292	IR 140x155x35	140	155	35	N1	20	90	-	25.53	-	YF
293	IR 140x155x42	140	155	42	N1	20	90	-	27.48	-	YF
294	IR 140x160x50	140	160	50	N1	20	90	-	33.38	-	YF
295	IR 140x160x52	140	160	52	N1	20	90	-	35.33	-	YF
296	IR 140x160x67	140	160	67	N1	20	90	-	47.11	-	YF
297	IR 150x165x32	150	165	32	N1	20	90	-	25.53	-	YF
298	IR 150x165x40	150	165	40	N1	20	90	-	27.48	-	YF
299	IR 150x165x42	150	165	42	N1	20	90	-	28.66	-	YF
300	IR 150x170x52	150	170	52	N1	20	90	-	31.41	-	YF

<b>Remark</b>	Technical supplement		
	Cage(s)	Precision	Grease
	Steel - <input checked="" type="checkbox"/>	Class 0 (JIS)	Nil
	Polymid - <input checked="" type="checkbox"/>		
Brass - <input checked="" type="checkbox"/>			

Qualified Sub-contractor(s)	Since
YF	2004
-	-
-	-

**INNER RINGS**  
**SERIES IR**

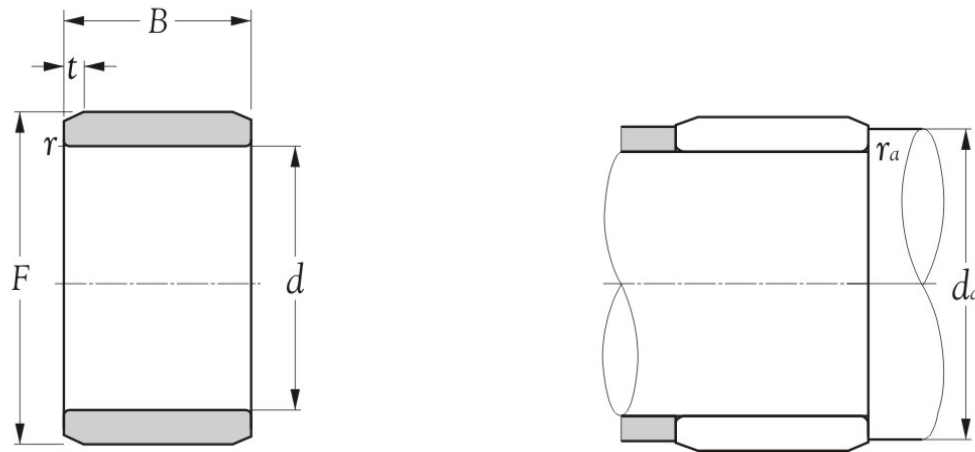

Items (20)	Data  Model nos.	Dimension			Packing method	Quantity  Min. order qty.  Pcs	Delivery  Days	-	2014-09-01	Compare percentages (%)	Production code(s)		
		Bearing sizes										Unit price structure  USD	Unit price structure  USD
		d	F	B									
		mm											
301	IR 150x170x60	150	170	60	N1	20	90	-	35.33	-	YF		
302	IR 160x175x40	160	175	40	N1	20	90	-	31.41	-	YF		
303	IR 160x180x60	160	180	60	N1	20	90	-	49.08	-	YF		
304	IR 170x185x45	170	185	45	N1	20	90	-	39.25	-	YF		
305	IR 170x190x60	170	190	60	N1	20	90	-	51.04	-	YF		
306	IR 180x195x45	180	195	45	N1	20	90	-	43.16	-	YF		
307	IR 180x205x69	180	205	69	N1	20	90	-	70.65	-	YF		
308	IR 190x210x50	190	210	50	N1	20	90	-	62.81	-	YF		
309	IR 190x215x69	190	215	69	N1	20	90	-	86.38	-	YF		
310	IR 200x220x50	200	220	50	N1	20	90	-	70.65	-	YF		
311	IR 200x225x80	200	225	80	N1	20	90	-	102.05	-	YF		
312	IR 220x240x50	220	240	50	N1	20	90	-	78.53	-	YF		
313	IR 220x245x80	220	245	80	N1	20	90	-	117.76	-	YF		
314	IR 240x265x60	240	265	60	N1	-	-	-	-	-	-		
315	IR 240x265x80	240	265	80	N1	-	-	-	-	-	-		
316	IR 320x360x118	320	360	118	N1	-	-	-	-	-	-		
317	IR 340x370x80	340	370	80	N1	-	-	-	-	-	-		
318	IR 340x380x118	340	380	118	N1	-	-	-	-	-	-		
319	IR 360x390x80	360	390	80	N1	-	-	-	-	-	-		
320	IR 360x400x118	360	400	118	N1	-	-	-	-	-	-		

<b>Remark</b>	Technical supplement		
	Cage(s)	Precision	Grease
	Steel - <input checked="" type="checkbox"/>	Class 0 (JIS)	Nil
	Polymid - <input checked="" type="checkbox"/>		
Brass - <input checked="" type="checkbox"/>			

Qualified Sub-contractor(s)	Since
YF	2004
-	-
-	-

INNER RINGS

SERIES IR

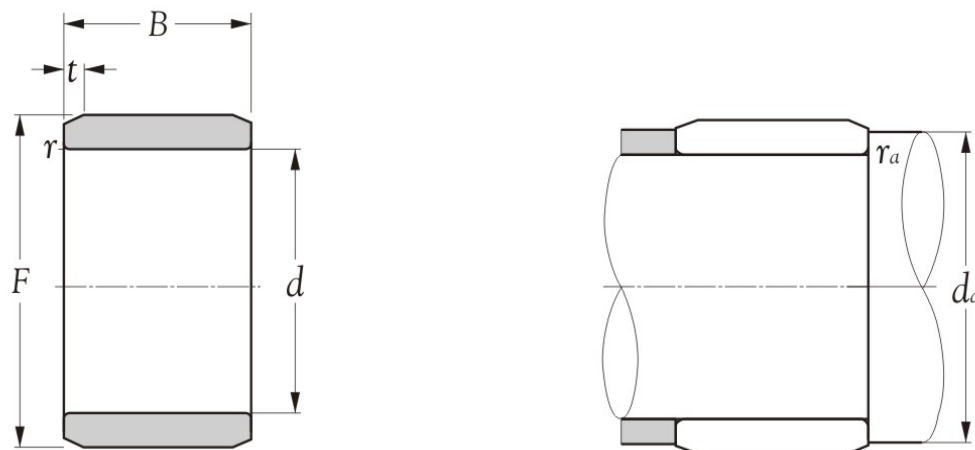

Items (5)	Data  Model nos.	Dimension			Packing method	Quantity  Min. order qty.  Pcs	Delivery  Days	-	2014-09-01	Compare percentages (%)	Production code(s)
		Bearing sizes						Unit price structure	Unit price structure		
		d	F	B				USD	USD		
321	IR 380x415x100	380	415	100	N1	-	-	-	-	-	-
322	IR 380x430x140	380	430	140	N1	-	-	-	-	-	-
323	IR 400x450x140	400	450	140	N1	-	-	-	-	-	-
324	IR 420x470x140	420	470	140	N1	-	-	-	-	-	-
325	IR 440x490x160	440	490	160	N1	-	-	-	-	-	-

Remark	Technical supplement		
	Cage(s)	Precision	Grease
	Steel - <input checked="" type="checkbox"/>	Class 0 (JIS)	Nil
	Polymid - <input checked="" type="checkbox"/>		
	Brass - <input checked="" type="checkbox"/>		

Qualified Sub-contractor(s)	Since
-	-
-	-
-	-

ONE-WAY CLUTCH MINIATURE TYPE  
SERIES **HF**

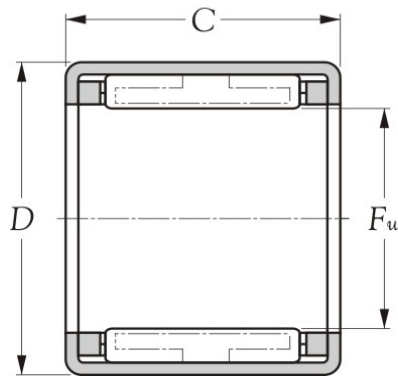

Items (11)	Data  Model nos.	Dimension			Packing method	Quantity  Min. order qty.  Pcs	Delivery  Days	-	2014-09-01	Compare percentages (%)	Production code(s)		
		Bearing sizes										Unit price structure  USD	Unit price structure  USD
		Fw	D	C									
		mm											
1	HF 0612 T2 (5x1)	6	10	12	N2	1,000	120	-	0.76	-	YF		
2	HF 0812 T2 (10x2)	8	12	12	N2	1,000	120	-	0.79	-	YF		
3	HF 1012 T2 (5x1)	10	14	12	N2	1,000	120	-	0.79	-	YF		
4	HF 1216 T2	12	18	16	N1	1,000	120	-	0.94	-	YF		
5	HF 1416 T2	14	20	16	N1	900	120	-	1.05	-	YF		
6	HF 1616 T2	16	22	16	N1	900	120	-	1.05	-	YF		
7	HF 1816 T2	18	24	16	N1	800	120	-	1.14	-	YF		
8	HF 2016 T2	20	26	16	N1	800	120	-	1.24	-	YF		
9	HF 2520 T2	25	32	20	N1	500	120	-	1.88	-	YF		
10	HF 3020 T2	30	37	20	N1	400	120	-	2.33	-	YF		
11	HF 3520 T2	35	42	20	N1	350	120	-	2.70	-	YF		

Remark	Technical supplement							
	Cage(s)	Precision	Grease					
	<table border="1"> <tr> <td>Steel -</td> <td>×</td> </tr> <tr> <td>Polymid -</td> <td>T2</td> </tr> <tr> <td>Brass -</td> <td>×</td> </tr> </table>	Steel -	×	Polymid -	T2	Brass -	×	Class 0 (JIS)
Steel -	×							
Polymid -	T2							
Brass -	×							

Qualified Sub-contractor(s)	Since
YF	2004
-	-
-	-

**DRAWN CUP NEEDLE CLUTCH**  
**SERIES HFL**

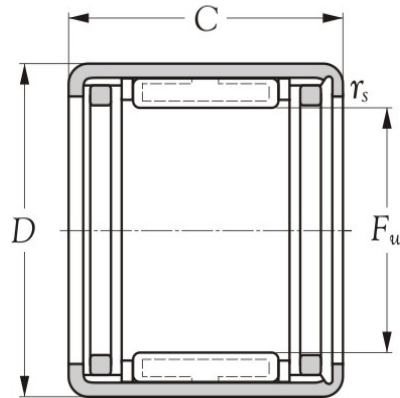

Items (12)	Data  Model nos.	Dimension			Packing method	Quantity  Min. order qty.  Pcs	Delivery  Days	-		Compare percentages (%)	Production code(s)
		Bearing sizes						Unit price structure  USD	2014-09-01  Unit price structure  USD		
		<i>F<sub>w</sub></i>	<i>D</i>	<i>C</i>							
		mm									
1	HFL 0408 T2 (10x2)	4	8	8	N2	500	120	-	1.74	-	YF
2	HFL 0615 T2 (5x1)	6	10	15	N2	600	120	-	1.70	-	YF
3	HFL 0822 T2 (10x2)	8	12	22	N2	500	120	-	1.88	-	YF
4	HFL 1022 T2 (5x1)	10	14	22	N2	450	120	-	1.98	-	YF
5	HFL 1226 T2	12	18	26	N1	450	120	-	2.05	-	YF
6	HFL 1426 T2	14	20	26	N1	450	120	-	2.11	-	YF
7	HFL 1626 T2	16	22	26	N1	400	120	-	2.33	-	YF
8	HFL 1826 T2	18	24	26	N1	350	120	-	2.46	-	YF
9	HFL 2026 T2	20	26	26	N1	350	120	-	2.70	-	YF
10	HFL 2530 T2	25	32	30	N1	300	120	-	2.90	-	YF
11	HFL 3030 T2	30	37	30	N1	300	120	-	3.40	-	YF
12	HFL 3530 T2	35	42	30	N1	250	120	-	4.08	-	YF

<b>Remark</b>	Technical supplement		
	Cage(s)	Precision	Grease
	Steel - X	Class 0 (JIS)	Nil
	Polymid - T2		
Brass - X			

Qualified Sub-contractor(s)	Since
YF	2004
-	-
-	-

MACHINED-RING NEEDLE ROLLER BEARINGS. SEPARABLE  
SERIES **RNAO**

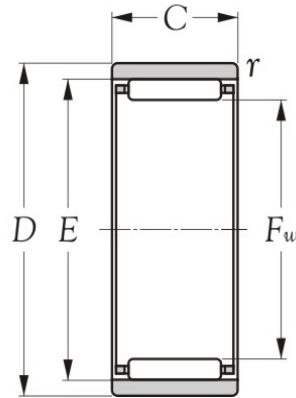

Items (20)	Data  Model nos.	Dimension			Packing method	Quantity		-	2014-09-01	Compare percentages (%)	Production code(s)		
		Bearing sizes				Min. order qty.	Delivery					Unit price structure	Unit price structure
		<i>F<sub>w</sub></i>	<i>D</i>	<i>C</i>									
		mm				Pcs							
1	<b>RNAO 5x10x8 (5x1)</b>	5	10	8	N2	400	120	-	<b>1.19</b>	-	YF		
2	<b>RNAO 6x13x8 (5x1)</b>	6	13	8	N2	400	120	-	<b>1.19</b>	-	YF		
3	<b>RNAO 7x14x8 (5x1)</b>	7	14	8	N2	400	120	-	<b>1.19</b>	-	YF		
4	<b>RNAO 8x15x10</b>	8	15	10	N1	400	120	-	<b>1.19</b>	-	YF		
5	<b>RNAO 10x17x10 (5x1)</b>	10	17	10	N2	400	120	-	<b>1.19</b>	-	YF		
6	<b>RNAO 10x20x12</b>	10	20	12	N1	350	120	-	<b>1.28</b>	-	YF		
7	<b>RNAO 12x19x13.5</b>	12	19	13.5	N1	400	120	-	<b>1.24</b>	-	YF		
8	<b>RNAO 12x22x12</b>	12	22	12	N1	350	120	-	<b>1.28</b>	-	YF		
9	<b>RNAO 14x22x13</b>	14	22	13	N1	350	120	-	<b>1.28</b>	-	YF		
10	<b>RNAO 14x26x12</b>	14	26	12	N1	300	120	-	<b>1.38</b>	-	YF		
11	<b>RNAO 15x23x13</b>	15	23	13	N1	300	120	-	<b>1.28</b>	-	YF		
12	<b>RNAO 16x24x13</b>	16	24	13	N1	300	120	-	<b>1.30</b>	-	YF		
13	<b>RNAO 16x28x12</b>	16	28	12	N1	250	120	-	<b>1.40</b>	-	YF		
14	<b>RNAO 17x25x13</b>	17	25	13	N1	300	120	-	<b>1.34</b>	-	YF		
15	<b>RNAO 18x26x13</b>	18	26	13	N1	250	120	-	<b>1.44</b>	-	YF		
16	<b>RNAO 18x30x12</b>	18	30	12	N1	200	120	-	<b>1.74</b>	-	YF		
17	<b>RNAO 20x28x13</b>	20	28	13	N1	250	120	-	<b>1.51</b>	-	YF		
18	<b>RNAO 20x32 x12</b>	20	32	12	N1	170	120	-	<b>2.01</b>	-	YF		
19	<b>RNAO 22x30x13</b>	22	30	13	N1	200	120	-	<b>1.74</b>	-	YF		
20	<b>RNAO 22x35x16</b>	22	35	16	N1	170	120	-	<b>2.01</b>	-	YF		

<b>Remark</b>	Technical supplement		
	Cage(s)	Precision	Grease
	Steel - <input checked="" type="checkbox"/>	Class 0 (JIS)	Nil
	Polymid - <input checked="" type="checkbox"/>		
Brass - <input checked="" type="checkbox"/>			

Qualified Sub-contractor(s)	Since
YF	2004
-	-
-	-



MACHINED-RING NEEDLE ROLLER BEARINGS. SEPARABLE  
SERIES **RNAO**

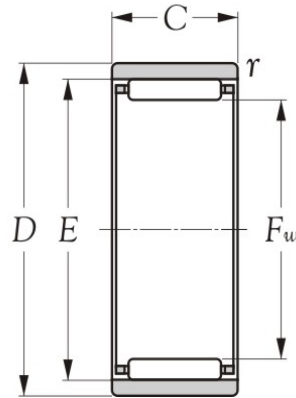

Items (20)	Data  Model nos.	Dimension			Packing method	Quantity  Min. order qty.  Pcs	Delivery  Days	-	2014-09-01	Compare percentages (%)	Production code(s)		
		Bearing sizes										Unit price structure  USD	Unit price structure  USD
		<i>F<sub>w</sub></i>	<i>D</i>	<i>C</i>									
		mm											
21	<b>RNAO 25x35x17</b>	25	35	17	N1	170	120	-	<b>2.06</b>	-	YF		
22	<b>RNAO 25x37x16</b>	25	37	16	N1	160	120	-	<b>2.29</b>	-	YF		
23	<b>RNAO 26x39x13</b>	26	39	13	N1	140	120	-	<b>2.58</b>	-	YF		
24	<b>RNAO 28x40x16</b>	28	40	16	N1	130	120	-	<b>2.70</b>	-	YF		
25	<b>RNAO 30x40x17</b>	30	40	17	N1	130	120	-	<b>2.78</b>	-	YF		
26	<b>RNAO 30x42x16</b>	30	42	16	N1	130	120	-	<b>2.85</b>	-	YF		
27	<b>RNAO 32x42x13</b>	32	42	13	N1	130	120	-	<b>2.85</b>	-	YF		
28	<b>RNAO 35x45x13</b>	35	45	13	N1	110	120	-	<b>3.20</b>	-	YF		
29	<b>RNAO 35x45x17</b>	35	45	17	N1	110	120	-	<b>3.34</b>	-	YF		
30	<b>RNAO 35x47x16</b>	35	47	16	N1	100	120	-	<b>3.49</b>	-	YF		
31	<b>RNAO 35x47x18</b>	35	47	18	N1	100	120	-	<b>3.66</b>	-	YF		
32	<b>RNAO 37x47x13</b>	37	47	13	N1	110	120	-	<b>3.34</b>	-	YF		
33	<b>RNAO 37x52x18</b>	37	52	18	N1	90	120	-	<b>3.99</b>	-	YF		
34	<b>RNAO 40x50x17</b>	40	50	17	N1	90	120	-	<b>3.94</b>	-	YF		
35	<b>RNAO 40x55x20</b>	40	55	20	N1	80	120	-	<b>4.38</b>	-	YF		
36	<b>RNAO 45x55x17</b>	45	55	17	N1	100	120	-	<b>3.91</b>	-	YF		
37	<b>RNAO 45x62x20</b>	45	62	20	N1	70	120	-	<b>5.04</b>	-	YF		
38	<b>RNAO 50x62x20</b>	50	62	20	N1	80	120	-	<b>4.53</b>	-	YF		
39	<b>RNAO 50x65x20</b>	50	65	20	N1	70	120	-	<b>5.04</b>	-	YF		
40	<b>RNAO 55x68x20</b>	55	68	20	N1	60	120	-	<b>6.13</b>	-	YF		

<b>Remark</b>	Technical supplement		
	Cage(s)	Precision	Grease
	Steel - <input checked="" type="checkbox"/>	Class 0 (JIS)	Nil
	Polymid - <input checked="" type="checkbox"/>		
Brass - <input checked="" type="checkbox"/>			

Qualified Sub-contractor(s)	Since
YF	2004
-	-
-	-

MACHINED-RING NEEDLE ROLLER BEARINGS. SEPARABLE  
SERIES **RNAO**

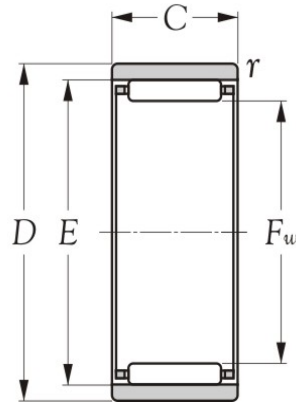

Items (14)	Data  Model nos.	Dimension			Packing method	Quantity  Min. order qty.  Pcs	Delivery  Days	-		Compare percentages (%)	Production code(s)
		Bearing sizes						Unit price structure	Unit price structure		
		<i>F<sub>w</sub></i>	<i>D</i>	<i>C</i>							
		mm						USD	USD		
41	<b>RNAO 55x68x25</b>	55	68	25	N1	100	120	-	<b>6.34</b>	-	YF
42	<b>RNAO 55x72x20</b>	55	72	20	N1	100	120	-	<b>7.85</b>	-	YF
43	<b>RNAO 60x78x20</b>	60	78	20	N1	100	120	-	<b>8.63</b>	-	YF
44	<b>RNAO 65x85x30</b>	65	85	30	N1	100	120	-	<b>11.76</b>	-	YF
45	<b>RNAO 70x90x30</b>	70	90	30	N1	100	120	-	<b>13.73</b>	-	YF
46	<b>RNAO 75x95x30</b>	75	95	30	N1	100	120	-	<b>15.71</b>	-	YF
47	<b>RNAO 80x95x30</b>	80	95	30	N1	100	120	-	<b>14.90</b>	-	YF
48	<b>RNAO 80x100x30</b>	80	100	30	N1	100	120	-	<b>17.68</b>	-	YF
49	<b>RNAO 85x105x25</b>	85	105	25	N1	90	120	-	<b>18.84</b>	-	YF
50	<b>RNAO 85x105x30</b>	85	105	30	N1	90	120	-	<b>20.41</b>	-	YF
51	<b>RNAO 90x105x26</b>	90	105	26	N1	90	120	-	<b>19.61</b>	-	YF
52	<b>RNAO 90x110x30</b>	90	110	30	N1	90	120	-	<b>21.59</b>	-	YF
53	<b>RNAO 95x115x30</b>	95	115	30	N1	90	120	-	<b>23.56</b>	-	YF
54	<b>RNAO 100x120x30</b>	100	120	30	N1	90	120	-	<b>27.48</b>	-	YF

Remark	Technical supplement		
	Cage(s)	Precision	Grease
	Steel - ✓ Polymid - ✕ Brass - ✕	Class 0 (JIS)	Nil

Qualified Sub-contractor(s)	Since
YF	2004
-	-
-	-

MACHINED-RING NEEDLE ROLLER BEARINGS. SEPARABLE  
SERIES **NAO**

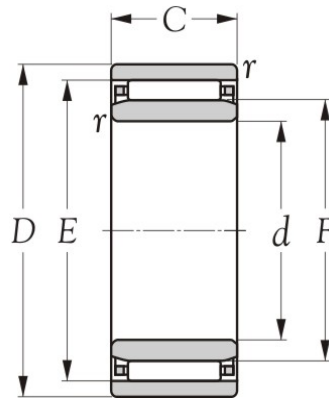

Items (20)	Data  Model nos.	Dimension			Packing method	Quantity  Min. order qty.  Pcs	Delivery  Days	Unit price structure  USD	2014-09-01  Unit price structure  USD	Compare percentages (%)	Production code(s)
		Bearing sizes									
		d	D	B							
1	NAO 6x17x10 (5x1)	6	17	10	N2	250	120	-	1.86	-	YF
2	NAO 7x20x12	7	20	12	N1	250	120	-	2.05	-	YF
3	NAO 9x22x12	9	22	12	N1	250	120	-	2.05	-	YF
4	NAO 10x22x13	10	22	13	N1	250	120	-	2.05	-	YF
5	NAO 10x26x12	10	26	12	N1	190	120	-	2.20	-	YF
6	NAO 12x24x13	12	24	13	N1	200	120	-	2.20	-	YF
7	NAO 12x28x12	12	28	12	N1	170	120	-	2.38	-	YF
8	NAO 15x28x13	15	28	13	N1	170	120	-	2.38	-	YF
9	NAO 15x32x12	15	32	12	N1	140	120	-	2.56	-	YF
10	NAO 17x30x13	17	30	13	N1	160	120	-	2.56	-	YF
11	NAO 17x35x16	17	35	16	N1	130	120	-	2.78	-	YF
12	NAO 20x35x17	20	35	17	N1	140	120	-	2.70	-	YF
13	NAO 20x37x16	20	37	16	N1	130	120	-	3.08	-	YF
14	NAO 25x40x17	25	40	17	N1	130	120	-	3.40	-	YF
15	NAO 25x42x16	25	42	16	N1	110	120	-	3.76	-	YF
16	NAO 29x42x13	29	42	13	N1	120	120	-	3.91	-	YF
17	NAO 30x45x13	30	45	13	N1	100	120	-	4.08	-	YF
18	NAO 30x45x17	30	45	17	N1	100	120	-	4.44	-	YF
19	NAO 30x47x16	30	47	16	N1	90	120	-	4.79	-	YF
20	NAO 30x47x18	30	47	18	N1	80	120	-	4.91	-	YF

Remark	Technical supplement		
	Cage(s)	Precision	Grease
	Steel - <input checked="" type="checkbox"/> Polymid - <input checked="" type="checkbox"/> Brass - <input checked="" type="checkbox"/>	Class 0 (JIS)	Nil

Qualified Sub-contractor(s)	Since
YF	2004
-	-
-	-

MACHINED-RING NEEDLE ROLLER BEARINGS. SEPARABLE  
SERIES **NAO**

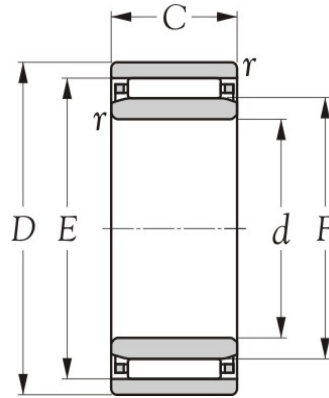

Items (21)	Data  Model nos.	Dimension			Packing method	Quantity  Min. order qty.  Pcs	Delivery  Days	-		Compare percentages (%)	Production code(s)
		Bearing sizes						Unit price structure	2014-09-01 Unit price structure		
		d	D	B							
		mm									
21	NAO 30x52x18	30	52	18	N1	70	120	-	5.10	-	YF
22	NAO 33x47x13	33	47	13	N1	90	120	-	4.79	-	YF
23	NAO 35x50x17	35	50	17	N1	90	120	-	5.10	-	YF
24	NAO 35x55x20	35	55	20	N1	70	120	-	5.46	-	YF
25	NAO 40x55x17	40	55	17	N1	80	120	-	5.46	-	YF
26	NAO 40x62x20	40	62	20	N1	70	120	-	6.45	-	YF
27	NAO 40x65x20	40	65	20	N1	70	120	-	6.80	-	YF
28	NAO 45x62x20	45	62	20	N1	70	120	-	6.13	-	YF
29	NAO 45x72x20	45	72	20	N1	70	120	-	8.51	-	YF
30	NAO 50x68x20	50	68	20	N1	60	120	-	7.84	-	YF
31	NAO 50x78x20	50	78	20	N1	60	120	-	9.54	-	YF
32	NAO 55x85x30	55	85	30	N1	60	120	-	12.93	-	YF
33	NAO 60x90x30	60	90	30	N1	30	120	-	14.60	-	YF
34	NAO 65x95x30	65	95	30	N1	30	120	-	18.84	-	YF
35	NAO 70x95x30	70	95	30	N1	30	120	-	17.68	-	YF
36	NAO 70x100x30	70	100	30	N1	30	120	-	19.61	-	YF
37	NAO 75x105x25	75	105	25	N1	30	120	-	21.59	-	YF
38	NAO 75x105x30	75	105	30	N1	30	120	-	23.56	-	YF
39	NAO 80x110x30	80	110	30	N1	30	120	-	27.48	-	YF
40	NAO 85x115x30	85	115	30	N1	30	120	-	31.41	-	YF
41	NAO 90x120x30	90	120	30	N1	30	120	-	35.33	-	YF

Remark	Technical supplement		
	Cage(s)	Precision	Grease
	Steel - ✓ Polymid - ✗ Brass - ✗	Class 0 (JIS)	Nil

Qualified Sub-contractor(s)	Since
YF	2004
-	-
-	-

**SEALING RINGS  
SERIES G, GD**

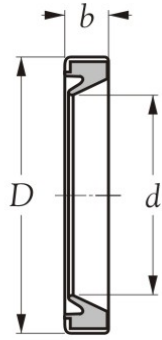

Type G

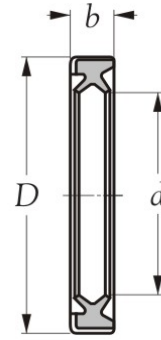

Type GD

Items (20)	Data  Model nos.	Dimension			Packing method	Quantity  Min. order qty.  Pcs	Delivery  Days	-		Compare percentages (%)	Production code(s)
		Bearing sizes						Unit price structure  USD	2014-09-01 Unit price structure  USD		
		d	D	b							
		mm									
1	G 4x8x2	4	8	2	N1	-	-	-	-	-	-
2	G 5x9x3	5	9	2	N1	-	-	-	-	-	-
3	G 5x10x2	5	10	2	N1	-	-	-	-	-	-
4	G 6x10x2	6	10	2	N1	-	-	-	-	-	-
5	G 6x12x2	6	12	2	N1	-	-	-	-	-	-
6	G 7x11x2	7	11	2	N1	-	-	-	-	-	-
7	G 7x14x2	7	14	2	N1	-	-	-	-	-	-
8	G 8x12x3	8	12	3	N1	-	-	-	-	-	-
9	G 8x15x3	8	15	3	N1	-	-	-	-	-	-
10	G 9x13x3	9	13	3	N1	-	-	-	-	-	-
11	G 9x16x3	9	16	3	N1	-	-	-	-	-	-
12	G 10x14x3	10	14	3	N1	-	-	-	-	-	-
13	G 10x17x3	10	17	3	N1	-	-	-	-	-	-
14	G 12x16x3	12	16	3	N1	-	-	-	-	-	-
15	G 12x18x3	12	18	3	N1	-	-	-	-	-	-
16	G 12x19x3	12	19	3	N1	-	-	-	-	-	-
17	G 13x19x3	13	19	3	N1	-	-	-	-	-	-
18	G 14x20x3	14	20	3	N1	-	-	-	-	-	-
19	G 14x21x3	14	21	3	N1	-	-	-	-	-	-
20	G 14x22x3	14	22	3	N1	-	-	-	-	-	-

<b>Remark</b>	Technical supplement		
	Cage(s)	Precision	Grease
	Steel - <input checked="" type="checkbox"/>	Class 0 (JIS)	Nil
	Polymid - <input checked="" type="checkbox"/>		
Brass - <input checked="" type="checkbox"/>			

Qualified Sub-contractor(s)	Since
YF	2004
-	-
-	-

**SEALING RINGS  
SERIES G, GD**

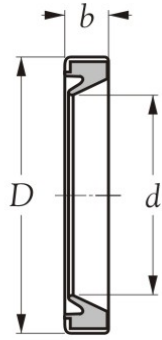

Type G

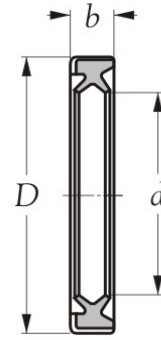

Type GD

Items (12)	Data  Model nos.	Dimension			Packing method	Quantity  Min. order qty.  Pcs	Delivery  Days	-		Compare percentages (%)	Production code(s)
		Bearing sizes						Unit price structure	2014-09-01 Unit price structure		
		d	D	b							
		mm									
21	G 15x21x3	15	21	3	N1	-	-	-	-	-	-
22	G 15x23x3	15	23	3	N1	-	-	-	-	-	-
23	G 16x22x3	16	22	3	N1	-	-	-	-	-	-
24	G 16x24x3	16	24	3	N1	-	-	-	-	-	-
25	G 16x25x3	16	25	3	N1	-	-	-	-	-	-
26	G 17x23x3	17	23	3	N1	-	-	-	-	-	-
27	G 17x25x3	17	25	3	N1	-	-	-	-	-	-
28	G 18x24x3	18	24	3	N1	-	-	-	-	-	-
29	G 18x26x4	18	26	4	N1	-	-	-	-	-	-
30	G 19x27x4	19	27	4	N1	-	-	-	-	-	-
31	G 20x26x4	20	26	4	N1	-	-	-	-	-	-
32	G 20x28x4	20	28	4	N1	-	-	-	-	-	-

<b>Remark</b>	Technical supplement		
	Cage(s)	Precision	Grease
	Steel - <input checked="" type="checkbox"/>	Class 0 (JIS)	Nil
	Polymid - <input checked="" type="checkbox"/>		
Brass - <input checked="" type="checkbox"/>			

Qualified Sub-contractor(s)	Since
YF	2004
-	-
-	-

**SEALING RINGS  
SERIES G, GD**

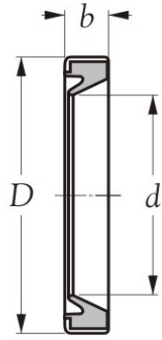

Type G

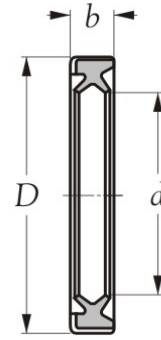

Type GD

Items (15)	Data  Model nos.	Dimension			Packing method	Quantity  Min. order qty.  Pcs	Delivery  Days	-		Compare percentages (%)	Production code(s)
		Bearing sizes						Unit price structure	2014-09-01		
		d	D	b				Unit price structure	Unit price structure		
		mm						USD	USD		
1	GD 14x20x3	14	20	3	N1	-	-	-	-	-	-
2	GD 14x21x3	14	21	3	N1	-	-	-	-	-	-
3	GD 14x22x3	14	22	3	N1	-	-	-	-	-	-
4	GD 15x21x3	15	21	3	N1	-	-	-	-	-	-
5	GD 15x23x3	15	23	3	N1	-	-	-	-	-	-
6	GD 16x22x3	16	22	3	N1	-	-	-	-	-	-
7	GD 16x24x3	16	24	3	N1	-	-	-	-	-	-
8	GD 16x25x3	16	25	3	N1	-	-	-	-	-	-
9	GD 17x23x3	17	23	3	N1	-	-	-	-	-	-
10	GD 17x25x3	17	25	3	N1	-	-	-	-	-	-
11	GD 18x24x3	18	24	3	N1	-	-	-	-	-	-
12	GD 18x26x4	18	26	4	N1	-	-	-	-	-	-
13	GD 19x27x4	19	27	4	N1	-	-	-	-	-	-
14	GD 20x26x4	20	26	4	N1	-	-	-	-	-	-
15	GD 20x28x4	20	28	4	N1	-	-	-	-	-	-

<b>Remark</b>	Technical supplement		
	Cage(s)	Precision	Grease
	Steel - <input checked="" type="checkbox"/>	Class 0 (JIS)	Nil
	Polymid - <input checked="" type="checkbox"/>		
Brass - <input checked="" type="checkbox"/>			

Qualified Sub-contractor(s)	Since
YF	2004
-	-
-	-

**SEALING RINGS  
SERIES G, GD**

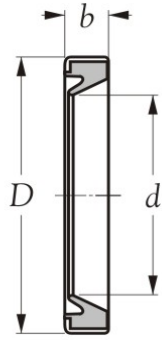

Type G

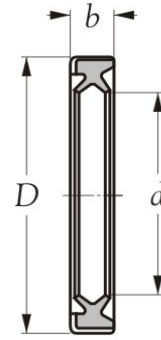

Type GD

Items (20)	Data  Model nos.	Dimension			Packing method	Quantity  Min. order qty.  Pcs	Delivery  Days	-		Compare percentages (%)	Production code(s)
		Bearing sizes						Unit price structure	2014-09-01 Unit price structure		
		d	D	b				USD	USD		
1	G 21x29x4	21	29	4	N1	-	-	-	-	-	-
2	G 22x28x4	22	28	4	N1	-	-	-	-	-	-
3	G 22x30x4	22	30	4	N1	-	-	-	-	-	-
4	G 24x32x4	24	32	4	N1	-	-	-	-	-	-
5	G 25x32x4	25	32	4	N1	-	-	-	-	-	-
6	G 25x33x4	25	33	4	N1	-	-	-	-	-	-
7	G 25x35x4	25	35	4	N1	-	-	-	-	-	-
8	G 26x34x4	26	34	4	N1	-	-	-	-	-	-
9	G 28x35x4	28	35	4	N1	-	-	-	-	-	-
10	G 28x37x4	28	37	4	N1	-	-	-	-	-	-
11	G 29x37x4	29	37	4	N1	-	-	-	-	-	-
12	G 29x38x4	29	38	4	N1	-	-	-	-	-	-
13	G 30x37x4	30	37	4	N1	-	-	-	-	-	-
14	G 30x40x4	30	40	4	N1	-	-	-	-	-	-
15	G 32x42x4	32	42	4	N1	-	-	-	-	-	-
16	G 32x45x4	32	45	4	N1	-	-	-	-	-	-
17	G 35x42x4	35	42	4	N1	-	-	-	-	-	-
18	G 35x45x4	35	45	4	N1	-	-	-	-	-	-
19	G 37x47x4	37	47	4	N1	-	-	-	-	-	-
20	G 38x48x4	38	48	4	N1	-	-	-	-	-	-

<b>Remark</b>	Technical supplement		
	Cage(s)	Precision	Grease
	Steel - <input checked="" type="checkbox"/>	Class 0 (JIS)	Nil
	Polymid - <input checked="" type="checkbox"/>		
Brass - <input checked="" type="checkbox"/>			

Qualified Sub-contractor(s)	Since
YF	2004
-	-
-	-



**SEALING RINGS  
SERIES G, GD**

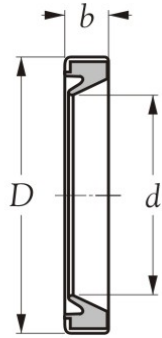

Type G

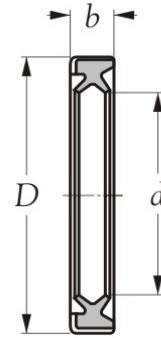

Type GD

Items (9)	Data  Model nos.	Dimension			Packing method	Quantity  Min. order qty.  Pcs	Delivery  Days	-		2014-09-01  Unit price structure  USD	Compare percentages (%)	Production code(s)
		Bearing sizes						Unit price structure  USD	Unit price structure  USD			
		d	D	b								
		mm										
21	G 40x47x4	40	47	4	N1	-	-	-	-	-	-	-
22	G 40x50x4	40	50	4	N1	-	-	-	-	-	-	-
23	G 40x52x4	40	52	4	N1	-	-	-	-	-	-	-
24	G 42x52x4	42	52	4	N1	-	-	-	-	-	-	-
25	G 43x53x4	43	53	4	N1	-	-	-	-	-	-	-
26	G 45x52x4	45	52	4	N1	-	-	-	-	-	-	-
27	G 45x55x4	45	55	4	N1	-	-	-	-	-	-	-
28	G 50x58x4	50	58	4	N1	-	-	-	-	-	-	-
29	G 50x62x4	50	62	4	N1	-	-	-	-	-	-	-

Remark	Technical supplement									
	Cage(s)	Precision	Grease							
	<table border="1"> <tr> <td>Steel -</td> <td>×</td> </tr> <tr> <td>Polymid -</td> <td>×</td> </tr> <tr> <td>Brass -</td> <td>×</td> </tr> </table>	Steel -	×	Polymid -	×	Brass -	×	<table border="1"> <tr> <td>Class 0 (JIS)</td> </tr> </table>	Class 0 (JIS)	<table border="1"> <tr> <td>Nil</td> </tr> </table>
Steel -	×									
Polymid -	×									
Brass -	×									
Class 0 (JIS)										
Nil										

Qualified Sub-contractor(s)	Since
YF	2004
-	-
-	-

**SEALING RINGS  
SERIES G, GD**

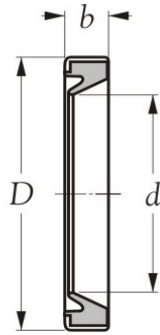

Type G

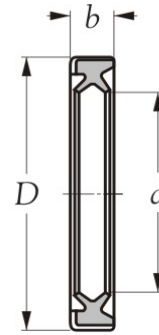

Type GD

Items (20)	Data  Model nos.	Dimension			Packing method	Quantity  Min. order qty.  Pcs	Delivery  Days	-		Compare percentages (%)	Production code(s)
		Bearing sizes						Unit price structure  USD	2014-09-01 Unit price structure  USD		
		d	D	b							
		mm									
1	GD 21x29x4	21	29	4	N1	-	-	-	-	-	-
2	GD 22x28x4	22	28	4	N1	-	-	-	-	-	-
3	GD 22x30x4	22	30	4	N1	-	-	-	-	-	-
4	GD 24x32x4	24	32	4	N1	-	-	-	-	-	-
5	GD 25x32x4	25	32	4	N1	-	-	-	-	-	-
6	GD 25x33x4	25	33	4	N1	-	-	-	-	-	-
7	GD 25x35x4	25	35	4	N1	-	-	-	-	-	-
8	GD 26x34x4	26	34	4	N1	-	-	-	-	-	-
9	GD 28x35x4	28	35	4	N1	-	-	-	-	-	-
10	GD 28x37x4	28	37	4	N1	-	-	-	-	-	-
11	GD 29x37x4	29	37	4	N1	-	-	-	-	-	-
12	GD 29x38x4	29	38	4	N1	-	-	-	-	-	-
13	GD 30x37x4	30	37	4	N1	-	-	-	-	-	-
14	GD 30x40x4	30	40	4	N1	-	-	-	-	-	-
15	GD 32x42x4	32	42	4	N1	-	-	-	-	-	-
16	GD 32x45x4	32	45	4	N1	-	-	-	-	-	-
17	GD 35x42x4	35	42	4	N1	-	-	-	-	-	-
18	GD 35x45x4	35	45	4	N1	-	-	-	-	-	-
19	GD 37x47x4	37	47	4	N1	-	-	-	-	-	-
20	GD 38x48x4	38	48	4	N1	-	-	-	-	-	-

Remark	Technical supplement		
	Cage(s)	Precision	Grease
	Steel - <input checked="" type="checkbox"/> Polymid - <input checked="" type="checkbox"/> Brass - <input checked="" type="checkbox"/>	Class 0 (JIS)	Nil

Qualified Sub-contractor(s)	Since
YF	2004
-	-
-	-

**SEALING RINGS  
SERIES G, GD**

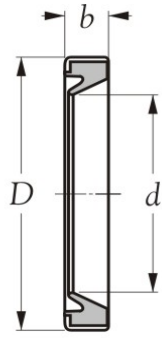

Type G

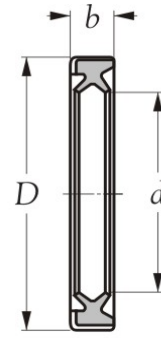

Type GD

Items (9)	Data  Model nos.	Dimension			Packing method	Quantity  Min. order qty.  Pcs	Delivery  Days	-		2014-09-01  Unit price structure  USD	Compare percentages (%)	Production code(s)
		Bearing sizes						Unit price structure  USD	Unit price structure  USD			
		d	D	b								
		mm										
21	GD 40x47x4	40	47	4	N1	-	-	-	-	-	-	-
22	GD 40x50x4	40	50	4	N1	-	-	-	-	-	-	-
23	GD 40x52x4	40	52	4	N1	-	-	-	-	-	-	-
24	GD 42x52x4	42	52	4	N1	-	-	-	-	-	-	-
25	GD 43x53x4	43	53	4	N1	-	-	-	-	-	-	-
26	GD 45x52x4	45	52	4	N1	-	-	-	-	-	-	-
27	GD 45x55x4	45	55	4	N1	-	-	-	-	-	-	-
28	GD 50x58x4	50	58	4	N1	-	-	-	-	-	-	-
29	GD 50x62x4	50	62	4	N1	-	-	-	-	-	-	-

<b>Remark</b>	Technical supplement		
	Cage(s)	Precision	Grease
	Steel - <input checked="" type="checkbox"/>	Class 0 (JIS)	Nil
	Polymid - <input checked="" type="checkbox"/>		
Brass - <input checked="" type="checkbox"/>			

Qualified Sub-contractor(s)	Since
YF	2004
-	-
-	-



# LINEAR MOTION



**LINEAR BALL BEARINGS**  
**SERIES LME..**

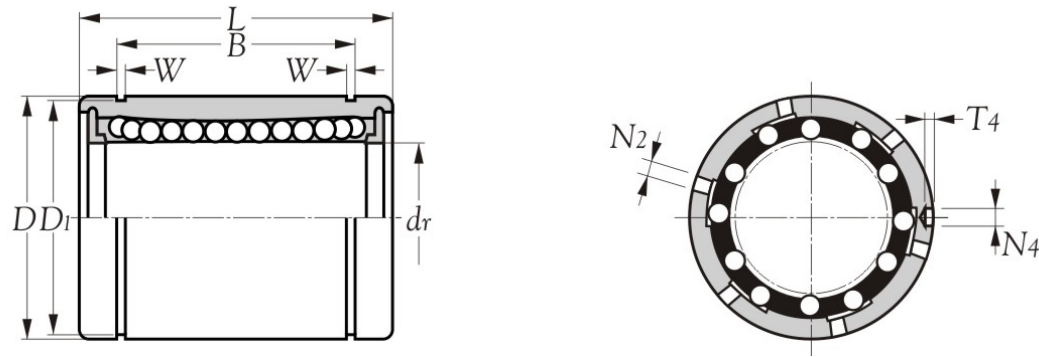

Items (10)	Data  Model nos.	Dimension			Packing method	Quantity  Min. order qty.	Delivery  Days	-		2014-09-01	Compare percentages (%)	Production code(s)
		Bearing sizes						Unit price structure	Unit price structure			
		d	D	L								
		mm				Pcs						
1	LME 8 A AS	8	16	25	N1	1,500	90	-	-	-	-	KBS
2	LME 10 A AS	10	19	29	N1	-	-	-	-	-	-	KBS
3	LME 12 A AS	12	22	32	N1	1,500	90	-	-	-	-	KBS
4	LME 16 A AS	16	26	36	N1	1,500	90	-	-	-	-	KBS
5	LME 20 A AS	20	32	45	N1	1,500	90	-	-	-	-	KBS
6	LME 25 A AS	25	40	58	N1	1,000	90	-	-	-	-	KBS
7	LME 30 A AS	30	47	68	N1	1,000	90	-	-	-	-	KBS
8	LME 40 A AS	40	62	80	N1	250	90	-	-	-	-	KBS
9	LME 50 A AS	50	75	100	N1	200	90	-	-	-	-	KBS
10	LME 60 A AS	60	90	125	N1	100	90	-	-	-	-	KBS

Remark : 1. "AS" means bearings contain with grease, grease holes and fixing holes.

Remark	Technical supplement		
	Retainer(s)	Precision	Grease
	Steel - ×	Class 0 (JIS)	Alvania S2 -25°C ~ +120°C
	Polymid - ✓		
	Brass - ×		

Qualified Sub-contractor(s)	Since
KBS	2003
-	-
-	-

**LINEAR BALL BEARINGS**  
**SERIES LME..**

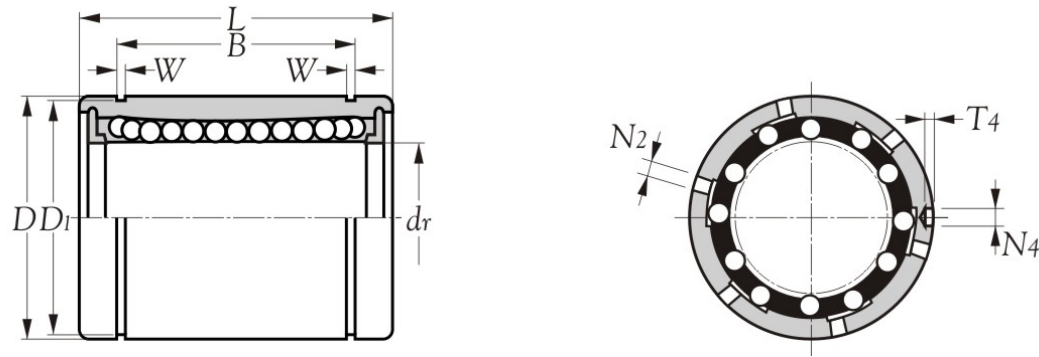

Items (10)	Data  Model nos.	Dimension			Packing method	Quantity  Min. order qty.	Delivery  Days	-		2014-09-01  Unit price structure	Compare percentages (%)	Production code(s)
		Bearing sizes						Unit price structure	Unit price structure			
		d	D	L								
		mm				Pcs			USD	USD		
1	LME 5 AS (20x1)	5	12	22	N2	-	-	-	-	-	-	KBS
2	LME 8 AS	8	16	25	N1	1,500	90	-	-	-	-	KBS
3	LME 12 AS	12	22	32	N1	1,500	90	-	-	-	-	KBS
4	LME 16 AS	16	26	36	N1	1,500	90	-	-	-	-	KBS
5	LME 20 AS	20	32	45	N1	1,500	90	-	-	-	-	KBS
6	LME 25 AS	25	40	58	N1	1,000	90	-	-	-	-	KBS
7	LME 30 AS	30	47	68	N1	1,000	90	-	-	-	-	KBS
8	LME 40 AS	40	62	80	N1	250	90	-	-	-	-	KBS
9	LME 50 AS	50	75	100	N1	200	90	-	-	-	-	KBS
10	LME 60 AS	60	90	125	N1	100	90	-	-	-	-	KBS

Remark : 1. "AS" means bearings contain with grease, grease holes and fixing holes.

Remark	Technical supplement		
	Retainer(s)	Precision	Grease
	Steel - ×	Class 0 (JIS)	Alvania S2 -25°C ~ +120°C
	Polymid - ✓		
	Brass - ×		

Qualified Sub-contractor(s)	Since
KBS	2003
-	-
-	-

LINEAR BALL BEARINGS

SERIES LME..

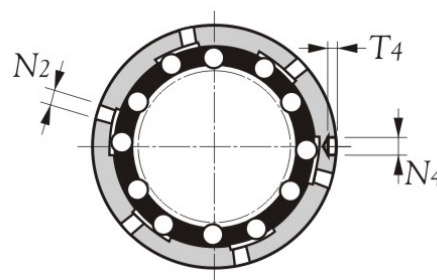
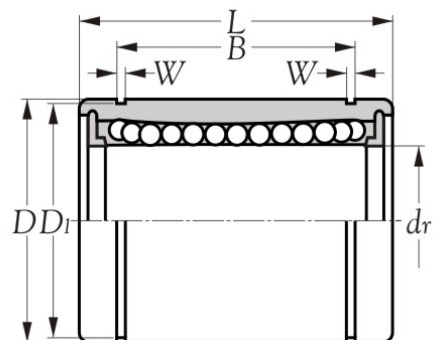

Items (10)	Data  Model nos.	Dimension			Packing method	Quantity  Min. order qty.  Pcs	Delivery  Days	-		2014-09-01  Unit price structure  USD	Compare percentages (%)	Production code(s)
		Bearing sizes						Unit price structure  USD	Unit price structure  USD			
		d	D	L								
		mm										
1	LME 8 A UU AS	8	16	25	N1	1,500	90	-	-	-	-	KBS
2	LME 10 A UU AS	10	19	29	N1	-	-	-	-	-	-	KBS
3	LME 12 A UU AS	12	22	32	N1	1,500	90	-	-	-	-	KBS
4	LME 16 A UU AS	16	26	36	N1	1,500	90	-	-	-	-	KBS
5	LME 20 A UU AS	20	32	45	N1	1,500	90	-	-	-	-	KBS
6	LME 25 A UU AS	25	40	58	N1	1,000	90	-	-	-	-	KBS
7	LME 30 A UU AS	30	47	68	N1	1,000	90	-	-	-	-	KBS
8	LME 40 A UU AS	40	62	80	N1	250	90	-	-	-	-	KBS
9	LME 50 A UU AS	50	75	100	N1	200	90	-	-	-	-	KBS
10	LME 60 A UU AS	60	90	125	N1	100	90	-	-	-	-	KBS

Remark : 1. "AS" means bearings contain with grease, grease holes and fixing holes.

Remark	Technical supplement		
	Retainer(s)	Precision	Grease
	Steel - ×	Class 0 (JIS)	Alvania S2 -25°C ~ +120°C
	Polymid - ✓		
	Brass - ×		

Qualified Sub-contractor(s)	Since
KBS	2003
-	-
-	-

**LINEAR BALL BEARINGS**  
**SERIES LME..**

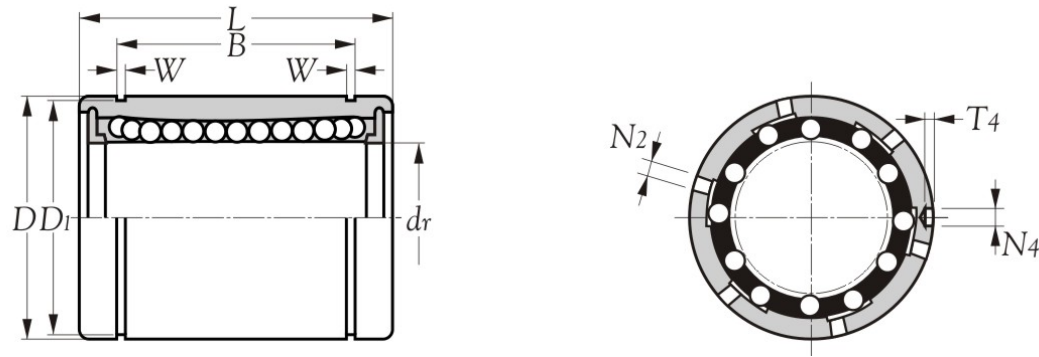

Items (10)	Data  Model nos.	Dimension			Packing method	Quantity  Min. order qty.  Pcs	Delivery  Days	-		Compare percentages (%)	Production code(s)
		Bearing sizes						Unit price structure  USD	2014-09-01  Unit price structure  USD		
		d	D	L							
		mm									
1	LME 5 UU AS (20x1)	5	12	22	N2	-	-	-	-	-	KBS
2	* LME 8 UU AS	8	16	25	N1	1,500	90	-	1.50	-	KBS
3	* LME 12 UU AS	12	22	32	N1	1,500	90	-	1.68	-	KBS
4	* LME 16 UU AS	16	26	36	N1	1,500	90	-	1.83	-	KBS
5	* LME 20 UU AS	20	32	45	N1	1,500	90	-	2.19	-	KBS
6	* LME 25 UU AS	25	40	58	N1	1,000	90	-	3.21	-	KBS
7	* LME 30 UU AS	30	47	68	N1	1,000	90	-	4.41	-	KBS
8	* LME 40 UU AS	40	62	80	N1	250	90	-	8.04	-	KBS
9	* LME 50 UU AS	50	75	100	N1	200	90	-	16.68	-	KBS
10	* LME 60 UU AS	60	90	125	N1	100	90	-	26.64	-	KBS

Remark : 1. "AS" means bearings contain with grease, grease holes and fixing holes.

Remark	Technical supplement		
	Retainer(s)	Precision	Grease
	Steel - ×	Class 0 (JIS)	Alvania S2 -25°C ~ +120°C
	Polymid - ✓		
	Brass - ×		

Qualified Sub-contractor(s)	Since
KBS	2003
-	-
-	-



**LINEAR BALL BEARINGS**  
**SERIES LME..**

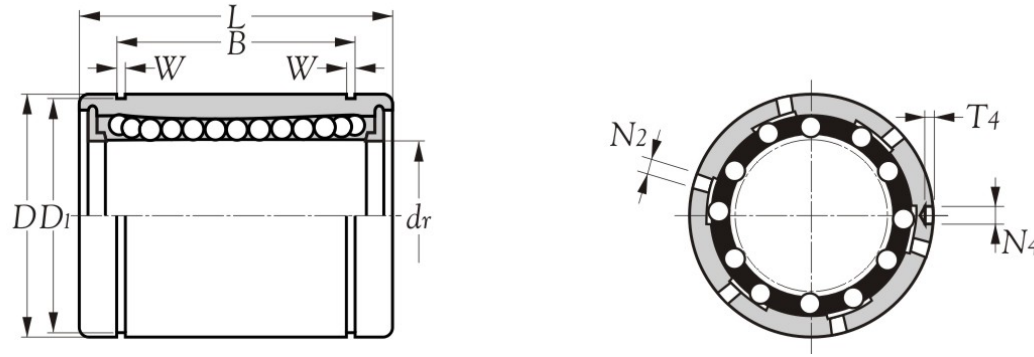

Items (10)	Data  Model nos.	Dimension			Packing method	Quantity  Min. order qty.  Pcs	Delivery  Days	-		2014-09-01  Unit price structure  USD	Compare percentages (%)	Production code(s)
		Bearing sizes						Unit price structure  USD	Unit price structure  USD			
		d	D	L								
		mm										
1	LME 8 A AS	8	16	25	N1	1,500	90	-	-	-	-	LOYS
2	LME 10 A AS	10	19	29	N1	-	-	-	-	-	-	LOYS
3	LME 12 A AS	12	22	32	N1	1,500	90	-	-	-	-	LOYS
4	LME 16 A AS	16	26	36	N1	1,500	90	-	-	-	-	LOYS
5	LME 20 A AS	20	32	45	N1	1,500	90	-	-	-	-	LOYS
6	LME 25 A AS	25	40	58	N1	1,000	90	-	-	-	-	LOYS
7	LME 30 A AS	30	47	68	N1	1,000	90	-	-	-	-	LOYS
8	LME 40 A AS	40	62	80	N1	250	90	-	-	-	-	LOYS
9	LME 50 A AS	50	75	100	N1	200	90	-	-	-	-	LOYS
10	LME 60 A AS	60	90	125	N1	100	90	-	-	-	-	LOYS

Remark : 1. "AS" means bearings contain with grease, grease holes and fixing holes.

Remark	Technical supplement		
	Retainer(s)	Precision	Grease
	Steel - ×	Class 0 (JIS)	Alvania S2 -25°C~+120°C
	Polymid - ✓		
	Brass - ×		

Qualified Sub-contractor(s)	Since
LOYS	2010
-	-
-	-

**LINEAR BALL BEARINGS**  
**SERIES LME..**

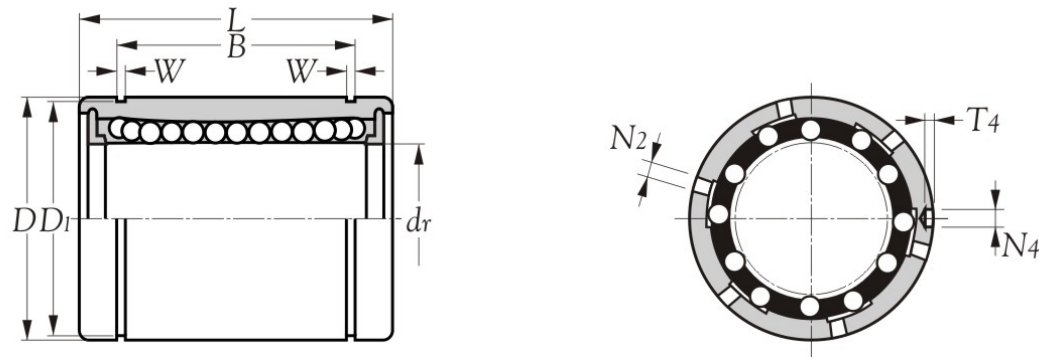

Items (10)	Data  Model nos.	Dimension			Packing method	Quantity  Min. order qty.	Delivery  Days	-		2014-09-01	Compare percentages (%)	Production code(s)
		Bearing sizes						Unit price structure	Unit price structure			
		d	D	L								
		mm				Pcs		USD	USD			
1	LME 5 AS (20x1)	5	12	22	N2	-	-	-	-	-	-	LOYS
2	LME 8 AS	8	16	25	N1	1,500	90	-	-	-	-	LOYS
3	LME 12 AS	12	22	32	N1	1,500	90	-	-	-	-	LOYS
4	LME 16 AS	16	26	36	N1	1,500	90	-	-	-	-	LOYS
5	LME 20 AS	20	32	45	N1	1,500	90	-	-	-	-	LOYS
6	LME 25 AS	25	40	58	N1	1,000	90	-	-	-	-	LOYS
7	LME 30 AS	30	47	68	N1	1,000	90	-	-	-	-	LOYS
8	LME 40 AS	40	62	80	N1	250	90	-	-	-	-	LOYS
9	LME 50 AS	50	75	100	N1	200	90	-	-	-	-	LOYS
10	LME 60 AS	60	90	125	N1	100	90	-	-	-	-	LOYS

Remark : 1. "AS" means bearings contain with grease, grease holes and fixing holes.

Remark	Technical supplement		
	Retainer(s)	Precision	Grease
	Steel - ×	Class 0 (JIS)	Alvania S2 -25°C~+120°C
	Polymid - ✓		
	Brass - ×		

Qualified Sub-contractor(s)	Since
LOYS	2010
-	-
-	-

**LINEAR BALL BEARINGS**  
**SERIES LME..**

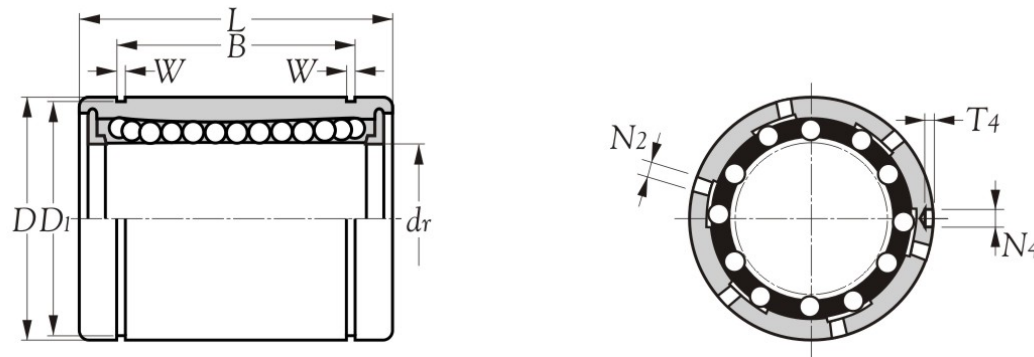

Items (10)	Data  Model nos.	Dimension			Packing method	Quantity  Min. order qty.	Delivery  Days	-		2014-09-01	Compare percentages (%)	Production code(s)
		Bearing sizes						Unit price structure	Unit price structure			
		d	D	L								
		mm				Pcs						
1	LME 8 A UU AS	8	16	25	N1	1,500	90	-	-	-	-	LOYS
2	LME 10 A UU AS	10	19	29	N1	-	-	-	-	-	-	LOYS
3	LME 12 A UU AS	12	22	32	N1	1,500	90	-	-	-	-	LOYS
4	LME 16 A UU AS	16	26	36	N1	1,500	90	-	-	-	-	LOYS
5	LME 20 A UU AS	20	32	45	N1	1,500	90	-	-	-	-	LOYS
6	LME 25 A UU AS	25	40	58	N1	1,000	90	-	-	-	-	LOYS
7	LME 30 A UU AS	30	47	68	N1	1,000	90	-	-	-	-	LOYS
8	LME 40 A UU AS	40	62	80	N1	250	90	-	-	-	-	LOYS
9	LME 50 A UU AS	50	75	100	N1	200	90	-	-	-	-	LOYS
10	LME 60 A UU AS	60	90	125	N1	100	90	-	-	-	-	LOYS

Remark : 1. "AS" means bearings contain with grease, grease holes and fixing holes.

Remark	Technical supplement		
	Retainer(s)	Precision	Grease
	Steel - ×	Class 0 (JIS)	Alvania S2 -25°C~+120°C
	Polymid - ✓		
	Brass - ×		

Qualified Sub-contractor(s)	Since
LOYS	2010
-	-
-	-

**LINEAR BALL BEARINGS**  
**SERIES LME..**

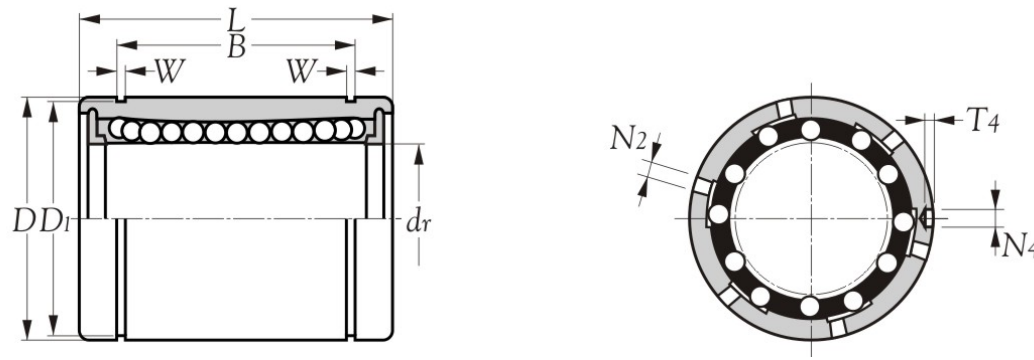

Items (10)	Data  Model nos.	Dimension			Packing method	Quantity  Min. order qty.	Delivery  Days	-		Compare percentages (%)	Production code(s)
		Bearing sizes						Unit price structure	Unit price structure		
		d	D	L							
		mm				Pcs		USD	USD		
1	LME 5 UU AS (20x1)	5	12	22	N2	-	-	-	-	-	LOYS
2	* LME 8 UU AS	8	16	25	N1	1,500	90	-	1.29	-	LOYS
3	* LME 12 UU AS	12	22	32	N1	1,500	90	-	1.48	-	LOYS
4	* LME 16 UU AS	16	26	36	N1	1,500	90	-	1.61	-	LOYS
5	* LME 20 UU AS	20	32	45	N1	1,500	90	-	1.90	-	LOYS
6	* LME 25 UU AS	25	40	58	N1	1,000	90	-	2.80	-	LOYS
7	* LME 30 UU AS	30	47	68	N1	1,000	90	-	3.83	-	LOYS
8	* LME 40 UU AS	40	62	80	N1	250	90	-	7.01	-	LOYS
9	* LME 50 UU AS	50	75	100	N1	200	90	-	14.89	-	LOYS
10	* LME 60 UU AS	60	90	125	N1	100	90	-	23.36	-	LOYS

Remark : 1. "AS" means bearings contain with grease, grease holes and fixing holes.

Remark	Technical supplement		
	Retainer(s)	Precision	Grease
	Steel - ×	Class 0 (JIS)	Alvania S2 -25°C~+120°C
	Polymid - ✓		
	Brass - ×		

Qualified Sub-contractor(s)	Since
LOYS	2010
-	-
-	-

**LINEAR BALL BEARINGS**  
**SERIES LME..AJ AS**

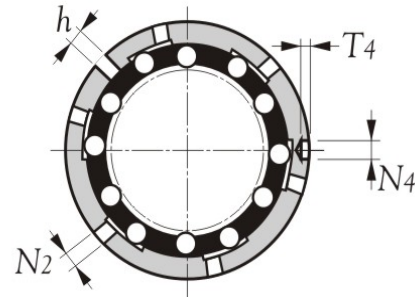
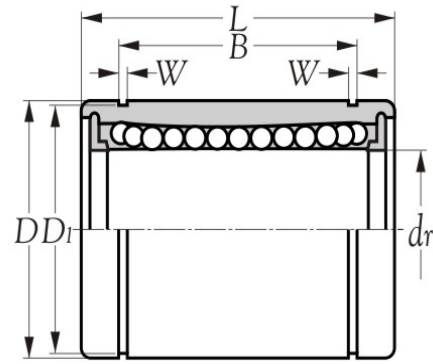

Items (8)	Data  Model nos.	Dimension			Packing method	Quantity  Min. order qty.	Delivery  Days	-		2014-09-01	Compare percentages (%)	Production code(s)
		Bearing sizes						Unit price structure	Unit price structure			
		d	D	L								
		mm				Pcs		USD	USD			
1	LME 12 A - AJ AS	12	22	32	N1	1,500	90	-	-	-	-	KBS
2	LME 16 A - AJ AS	16	26	36	N1	1,500	90	-	-	-	-	KBS
3	LME 20 A - AJ AS	20	32	45	N1	1,500	90	-	-	-	-	KBS
4	LME 25 A - AJ AS	25	40	58	N1	1,000	90	-	-	-	-	KBS
5	LME 30 A - AJ AS	30	47	68	N1	1,000	90	-	-	-	-	KBS
6	LME 40 A - AJ AS	40	62	80	N1	250	90	-	-	-	-	KBS
7	LME 50 A - AJ AS	50	75	100	N1	-	-	-	-	-	-	KBS
8	LME 60 A - AJ AS	60	90	125	N1	-	-	-	-	-	-	KBS

Remark : 1. "AS" means bearings contain with grease, grease holes and fixing holes.

Remark	Technical supplement		
	Retainer(s)	Precision	Grease
	Steel - ×	Class 0 (JIS)	Alvania S2 -25°C ~ +120°C
	Polymid - ✓		
	Brass - ×		

Qualified Sub-contractor(s)	Since
KBS	2003
-	-
-	-

LINEAR BALL BEARINGS  
SERIES LME..AJ AS

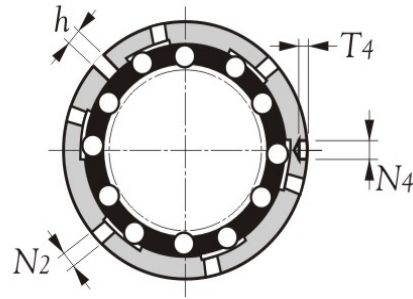
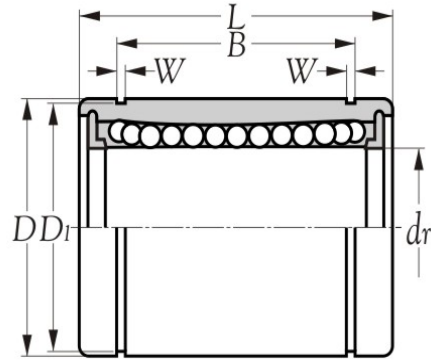

Items (10)	Data  Model nos.	Dimension			Packing method	Quantity  Min. order qty.	Delivery  Days	-		2014-09-01	Compare percentages (%)	Production code(s)
		Bearing sizes						Unit price structure	Unit price structure			
		d	D	L								
		mm				Pcs		USD	USD			
1	LME 5 AJ AS (20x1)	5	12	22	N2	-	-	-	-	-	-	KBS
2	LME 8 AJ AS	8	16	25	N1	-	-	-	-	-	-	KBS
3	LME 12 AJ AS	12	22	32	N1	1,500	90	-	-	-	-	KBS
4	LME 16 AJ AS	16	26	36	N1	1,500	90	-	-	-	-	KBS
5	LME 20 AJ AS	20	32	45	N1	1,500	90	-	-	-	-	KBS
6	LME 25 AJ AS	25	40	58	N1	1,000	90	-	-	-	-	KBS
7	LME 30 AJ AS	30	47	68	N1	1,000	90	-	-	-	-	KBS
8	LME 40 AJ AS	40	62	80	N1	250	90	-	-	-	-	KBS
9	LME 50 AJ AS	50	75	100	N1	-	-	-	-	-	-	KBS
10	LME 60 AJ AS	60	90	125	N1	-	-	-	-	-	-	KBS

Remark : 1. "AS" means bearings contain with grease, grease holes and fixing holes.

Remark	Technical supplement		
	Retainer(s)	Precision	Grease
	Steel - ×	Class 0 (JIS)	Alvania S2 -25°C~+120°C
	Polymid - ✓		
	Brass - ×		

Qualified Sub-contractor(s)	Since
KBS	2003
-	-
-	-

**LINEAR BALL BEARINGS**  
**SERIES LME..AJ AS**

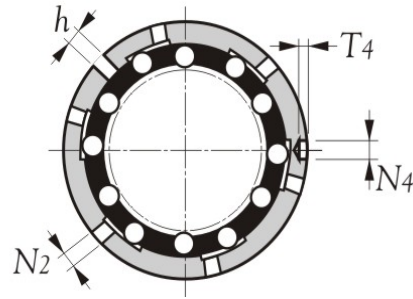
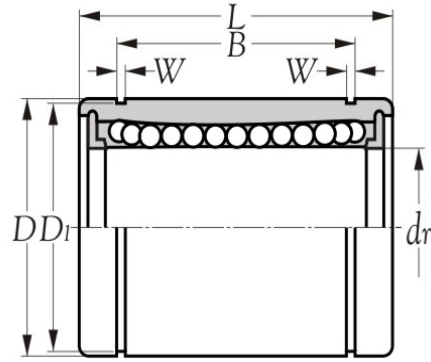

Items (8)	Data  Model nos.	Dimension			Packing method	Quantity  Min. order qty.	Delivery  Days	-		2014-09-01	Compare percentages (%)	Production code(s)
		Bearing sizes						Unit price structure	Unit price structure			
		d	D	L								
		mm				Pcs		USD	USD			
1	LME 12 A - UUAJ AS	12	22	32	N1	1,500	90	-	-	-	-	KBS
2	LME 16 A - UUAJ AS	16	26	36	N1	1,500	90	-	-	-	-	KBS
3	LME 20 A - UUAJ AS	20	32	45	N1	1,500	90	-	-	-	-	KBS
4	LME 25 A - UUAJ AS	25	40	58	N1	1,000	90	-	-	-	-	KBS
5	LME 30 A - UUAJ AS	30	47	68	N1	1,000	90	-	-	-	-	KBS
6	LME 40 A - UUAJ AS	40	62	80	N1	250	90	-	-	-	-	KBS
7	LME 50 A - UUAJ AS	50	75	100	N1	-	-	-	-	-	-	KBS
8	LME 60 A - UUAJ AS	60	90	125	N1	-	-	-	-	-	-	KBS

Remark : 1. "AS" means bearings contain with grease, grease holes and fixing holes.

Remark	Technical supplement		
	Retainer(s)	Precision	Grease
	Steel - ×	Class 0 (JIS)	Alvania S2 -25°C ~ +120°C
	Polymid - ✓		
	Brass - ×		

Qualified Sub-contractor(s)	Since
KBS	2003
-	-
-	-

LINEAR BALL BEARINGS  
SERIES LME..AJ AS

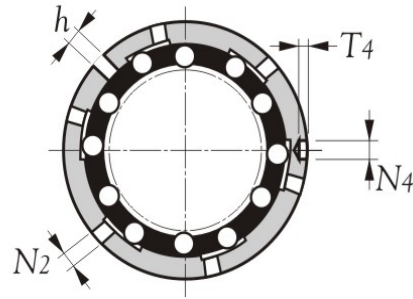
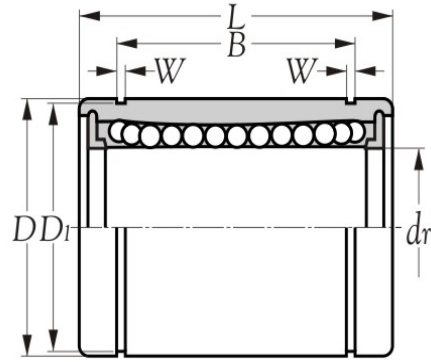

Items (10)	Data  Model nos.	Dimension			Packing method	Quantity  Min. order qty.	Delivery  Days	-		Compare percentages (%)	Production code(s)
		Bearing sizes						Unit price structure	Unit price structure		
		d	D	L							
		mm				Pcs		USD	USD		
1	LME 5 UUAJ AS (20x1)	5	12	22	N2	-	-	-	-	-	KBS
2	LME 8 UUAJ AS	8	16	25	N1	-	-	-	-	-	KBS
3	LME 12 UUAJ AS	12	22	32	N1	1500	90	-	2.01	-	KBS
4	LME 16 UUAJ AS	16	26	36	N1	1500	90	-	2.11	-	KBS
5	* LME 20 UUAJ AS	20	32	45	N1	1500	90	-	2.49	-	KBS
6	* LME 25 UUAJ AS	25	40	58	N1	1000	90	-	3.69	-	KBS
7	* LME 30 UUAJ AS	30	47	68	N1	1000	90	-	5.04	-	KBS
8	* LME 40 UUAJ AS	40	62	80	N1	250	90	-	9.16	-	KBS
9	LME 50 UUAJ AS	50	75	100	N1	-	-	-	-	-	KBS
10	LME 60 UUAJ AS	60	90	125	N1	-	-	-	-	-	KBS

Remark : 1. "AS" means bearings contain with grease, grease holes and fixing holes.

Remark	Technical supplement		
	Retainer(s)	Precision	Grease
	Steel - ×	Class 0 (JIS)	Alvania S2 -25°C~+120°C
	Polymid - ✓		
	Brass - ×		

Qualified Sub-contractor(s)	Since
KBS	2003
-	-
-	-



**LINEAR BALL BEARINGS**  
**SERIES LME..AJ AS**

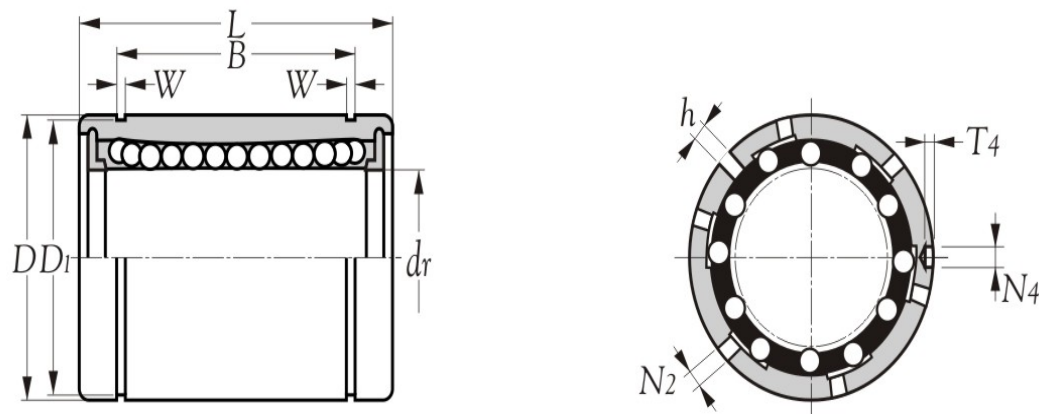

Items (8)	Data  Model nos.	Dimension			Packing method	Quantity  Min. order qty.  Pcs	Delivery  Days	-		2014-09-01  Unit price structure  USD	Compare percentages (%)	Production code(s)
		Bearing sizes						Unit price structure  USD	Unit price structure  USD			
		d	D	L								
		mm										
1	LME 12 A - AJ AS	12	22	32	N1	1,500	90	-	-	-	-	LOYS
2	LME 16 A - AJ AS	16	26	36	N1	1,500	90	-	-	-	-	LOYS
3	LME 20 A - AJ AS	20	32	45	N1	1,500	90	-	-	-	-	LOYS
4	LME 25 A - AJ AS	25	40	58	N1	1,000	90	-	-	-	-	LOYS
5	LME 30 A - AJ AS	30	47	68	N1	1,000	90	-	-	-	-	LOYS
6	LME 40 A - AJ AS	40	62	80	N1	250	90	-	-	-	-	LOYS
7	LME 50 A - AJ AS	50	75	100	N1	-	-	-	-	-	-	LOYS
8	LME 60 A - AJ AS	60	90	125	N1	-	-	-	-	-	-	LOYS

Remark : 1. "AS" means bearings contain with grease, grease holes and fixing holes.

Remark	Technical supplement		
	Retainer(s)	Precision	Grease
	Steel - <input type="checkbox"/>	Class 0 (JIS)	Alvania S2 -25°C ~ +120°C
	Polymid - <input checked="" type="checkbox"/>		
	Brass - <input type="checkbox"/>		

Qualified Sub-contractor(s)	Since
LOYS	2010
-	-
-	-

**LINEAR BALL BEARINGS**  
**SERIES LME..AJ AS**

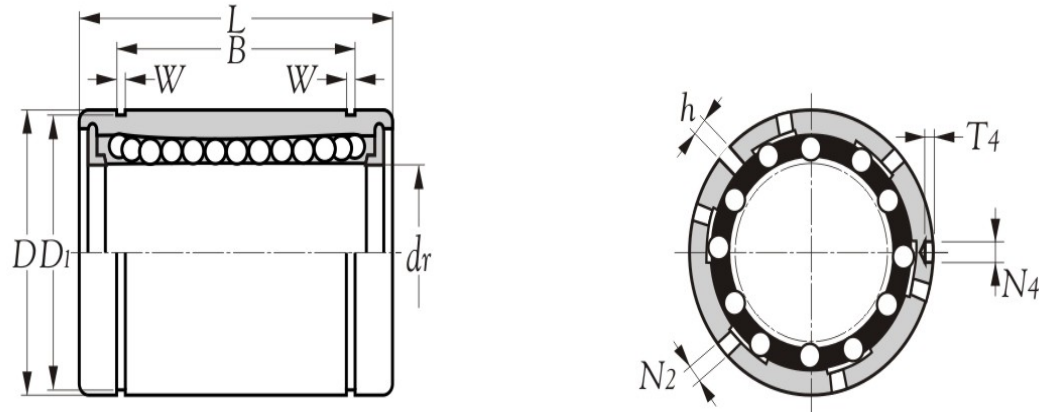

Items (10)	Data  Model nos.	Dimension			Packing method	Quantity  Min. order qty.	Delivery  Days	-		2014-09-01  Unit price structure	Compare percentages (%)	Production code(s)
		Bearing sizes						Unit price structure	Unit price structure			
		d	D	L								
		mm				Pcs			USD	USD		
1	LME 5 AJ AS (20x1)	5	12	22	N2	-	-	-	-	-	-	LOYS
2	LME 8 AJ AS	8	16	25	N1	-	-	-	-	-	-	LOYS
3	LME 12 AJ AS	12	22	32	N1	1,500	90	-	-	-	-	LOYS
4	LME 16 AJ AS	16	26	36	N1	1,500	90	-	-	-	-	LOYS
5	LME 20 AJ AS	20	32	45	N1	1,500	90	-	-	-	-	LOYS
6	LME 25 AJ AS	25	40	58	N1	1,000	90	-	-	-	-	LOYS
7	LME 30 AJ AS	30	47	68	N1	1,000	90	-	-	-	-	LOYS
8	LME 40 AJ AS	40	62	80	N1	250	90	-	-	-	-	LOYS
9	LME 50 AJ AS	50	75	100	N1	-	-	-	-	-	-	LOYS
10	LME 60 AJ AS	60	90	125	N1	-	-	-	-	-	-	LOYS

Remark : 1. "AS" means bearings contain with grease, grease holes and fixing holes.

Remark	Technical supplement		
	Retainer(s)	Precision	Grease
	Steel - ×	Class 0 (JIS)	Alvania S2 -25°C ~ +120°C
	Polymid - ✓		
	Brass - ×		

Qualified Sub-contractor(s)	Since
LOYS	2010
-	-
-	-

**LINEAR BALL BEARINGS**  
**SERIES LME..AJ AS**

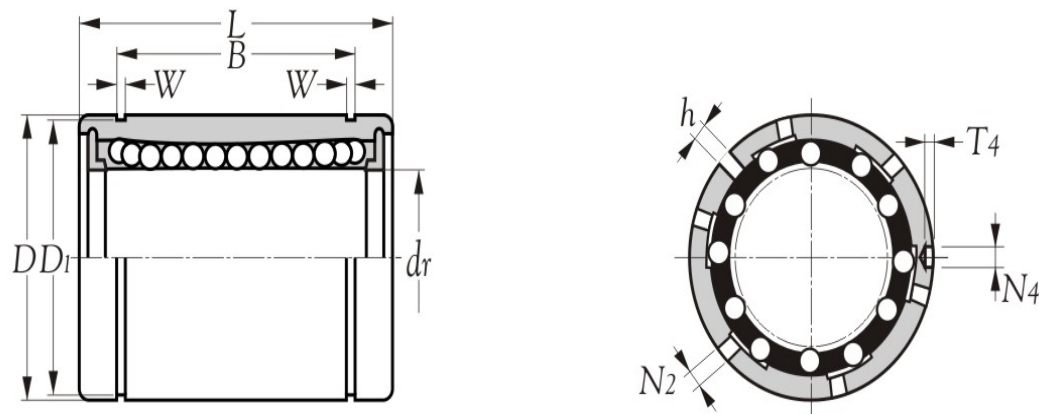

Items (8)	Data  Model nos.	Dimension			Packing method	Quantity  Min. order qty.	Delivery  Days	-		2014-09-01	Compare percentages (%)	Production code(s)
		Bearing sizes						Unit price structure	Unit price structure			
		d	D	L								
		mm				Pcs						
1	LME 12 A - UUAJ AS	12	22	32	N1	1,500	90	-	-	-	-	LOYS
2	LME 16 A - UUAJ AS	16	26	36	N1	1,500	90	-	-	-	-	LOYS
3	LME 20 A - UUAJ AS	20	32	45	N1	1,500	90	-	-	-	-	LOYS
4	LME 25 A - UUAJ AS	25	40	58	N1	1,000	90	-	-	-	-	LOYS
5	LME 30 A - UUAJ AS	30	47	68	N1	1,000	90	-	-	-	-	LOYS
6	LME 40 A - UUAJ AS	40	62	80	N1	250	90	-	-	-	-	LOYS
7	LME 50 A - UUAJ AS	50	75	100	N1	-	-	-	-	-	-	LOYS
8	LME 60 A - UUAJ AS	60	90	125	N1	-	-	-	-	-	-	LOYS

Remark : 1. "AS" means bearings contain with grease, grease holes and fixing holes.

Remark	Technical supplement		
	Retainer(s)	Precision	Grease
	Steel - ×	Class 0 (JIS)	Alvania S2 -25°C ~ +120°C
	Polymid - ✓		
	Brass - ×		

Qualified Sub-contractor(s)	Since
LOYS	2010
-	-
-	-

**LINEAR BALL BEARINGS**  
**SERIES LME..AJ AS**

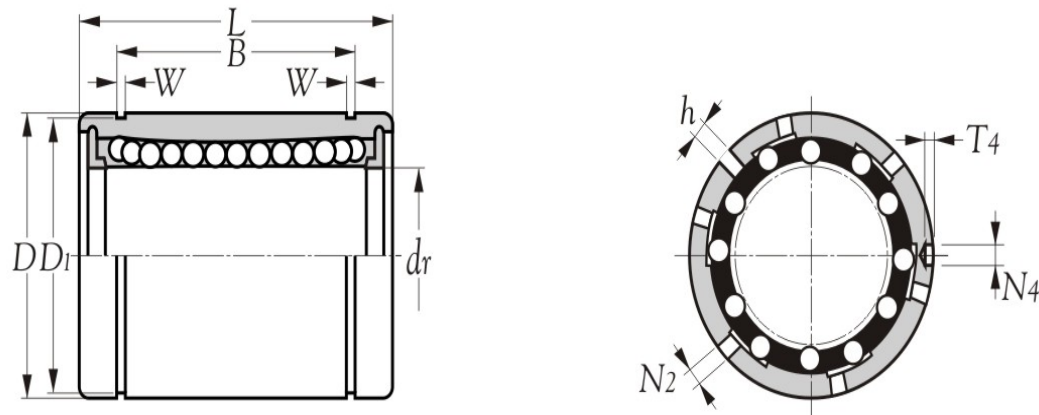

Items (10)	Data  Model nos.	Dimension			Packing method	Quantity  Min. order qty.	Delivery  Days	-		Compare percentages (%)	Production code(s)
		Bearing sizes						Unit price structure	Unit price structure		
		d	D	L							
		mm				Pcs		USD	USD		
1	LME 5 UUAJ AS (20x1)	5	12	22	N2	-	-	-	-	-	LOYS
2	LME 8 UUAJ AS	8	16	25	N1	-	-	-	-	-	LOYS
3	LME 12 UUAJ AS	12	22	32	N1	1,500	90	-	1.76	-	LOYS
4	LME 16 UUAJ AS	16	26	36	N1	1,500	90	-	1.84	-	LOYS
5	* LME 20 UUAJ AS	20	32	45	N1	1,500	90	-	2.19	-	LOYS
6	* LME 25 UUAJ AS	25	40	58	N1	1,000	90	-	3.23	-	LOYS
7	* LME 30 UUAJ AS	30	47	68	N1	1,000	90	-	4.38	-	LOYS
8	* LME 40 UUAJ AS	40	62	80	N1	250	90	-	8.00	-	LOYS
9	LME 50 UUAJ AS	50	75	100	N1	-	-	-	-	-	LOYS
10	LME 60 UUAJ AS	60	90	125	N1	-	-	-	-	-	LOYS

Remark : 1. "AS" means bearings contain with grease, grease holes and fixing holes.

Remark	Technical supplement		
	Retainer(s)	Precision	Grease
	Steel - <input type="checkbox"/>	Class 0 (JIS)	Alvania S2 -25°C ~ +120°C
	Polymid - <input checked="" type="checkbox"/>		
	Brass - <input type="checkbox"/>		

Qualified Sub-contractor(s)	Since
LOYS	2010
-	-
-	-

**LINEAR BALL BEARINGS**  
**SERIES LME..OP**

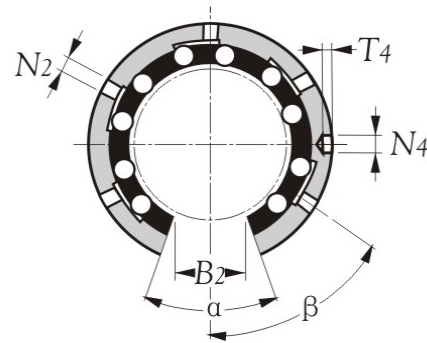
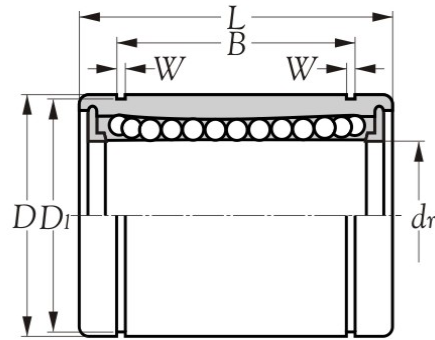

Items (8)	Data  Model nos.	Dimension			Packing method	Quantity  Min. order qty.	Delivery  Days	-		2014-09-01	Compare percentages (%)	Production code(s)
		Bearing sizes						Unit price structure	Unit price structure			
		d	D	L								
		mm				Pcs						
1	LME 12 A OP	12	22	32	N1	1,500	90	-	-	-	-	KBS
2	LME 16 A OP	16	26	36	N1	1,500	90	-	-	-	-	KBS
3	LME 20 A OP	20	32	45	N1	1,500	90	-	-	-	-	KBS
4	LME 25 A OP	25	40	58	N1	1,000	90	-	-	-	-	KBS
5	LME 30 A OP	30	47	68	N1	1,000	90	-	-	-	-	KBS
6	LME 40 A OP	40	62	80	N1	250	90	-	-	-	-	KBS
7	LME 50 A OP	50	75	100	N1	-	-	-	-	-	-	KBS
8	LME 60 A OP	60	90	125	N1	-	-	-	-	-	-	KBS

Remark : 1. "AS" means bearings contain with grease, grease holes and fixing holes.

Remark	Technical supplement		
	Retainer(s)	Precision	Grease
	Steel - ×	Class 0 (JIS)	Alvania S2 -25°C ~ +120°C
	Polymid - ✓		
	Brass - ×		

Qualified Sub-contractor(s)	Since
KBS	2003
-	-
-	-

**LINEAR BALL BEARINGS**  
**SERIES LME..OP**

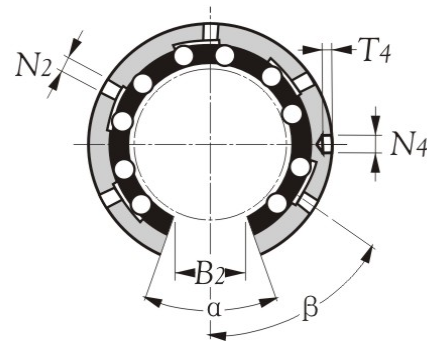
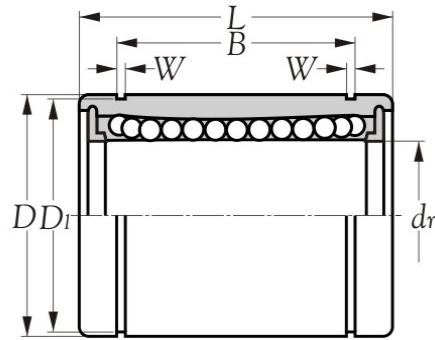

Items (8)	Data  Model nos.	Dimension			Packing method	Quantity  Min. order qty.	Delivery  Days	-		2014-09-01	Compare percentages (%)	Production code(s)
		Bearing sizes						Unit price structure	Unit price structure			
		d	D	L								
		mm				Pcs						
1	LME 12 OP AS	12	22	32	N1	1,500	90	-	-	-	-	KBS
2	LME 16 OP AS	16	26	36	N1	1,500	90	-	-	-	-	KBS
3	LME 20 OP AS	20	32	45	N1	1,500	90	-	-	-	-	KBS
4	LME 25 OP AS	25	40	58	N1	1,000	90	-	-	-	-	KBS
5	LME 30 OP AS	30	47	68	N1	1,000	90	-	-	-	-	KBS
6	LME 40 OP AS	40	62	80	N1	250	90	-	-	-	-	KBS
7	LME 50 OP AS	50	75	100	N1	-	-	-	-	-	-	KBS
8	LME 60 OP AS	60	90	125	N1	-	-	-	-	-	-	KBS

Remark : 1. "AS" means bearings contain with grease, grease holes and fixing holes.

Remark	Technical supplement		
	Retainer(s)	Precision	Grease
	Steel - ×	Class 0 (JIS)	Alvania S2 -25°C ~ +120°C
	Polymid - ✓		
	Brass - ×		

Qualified Sub-contractor(s)	Since
KBS	2003
-	-
-	-

**LINEAR BALL BEARINGS**  
**SERIES LME..OP**

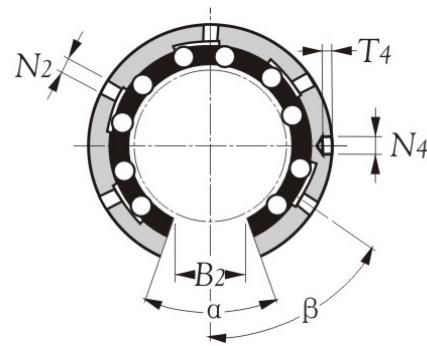
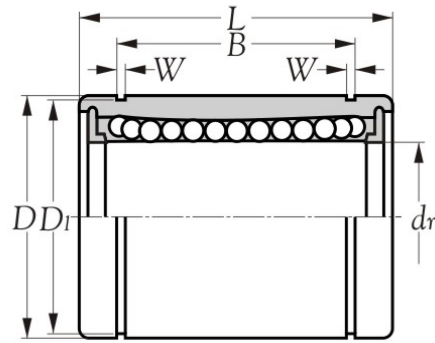

Items (8)	Data  Model nos.	Dimension			Packing method	Quantity  Min. order qty.	Delivery  Days	-		2014-09-01  Unit price structure	Compare percentages (%)	Production code(s)
		Bearing sizes						Unit price structure	Unit price structure			
		d	D	L								
		mm				Pcs			USD	USD		
1	LME 12 A UUOP AS	12	22	32	N1	1,500	90	-	-	-	-	KBS
2	LME 16 A UUOP AS	16	26	36	N1	1,500	90	-	-	-	-	KBS
3	LME 20 A UUOP AS	20	32	45	N1	1,500	90	-	-	-	-	KBS
4	LME 25 A UUOP AS	25	40	58	N1	1,000	90	-	-	-	-	KBS
5	LME 30 A UUOP AS	30	47	68	N1	1,000	90	-	-	-	-	KBS
6	LME 40 A UUOP AS	40	62	80	N1	250	90	-	-	-	-	KBS
7	LME 50 A UUOP AS	50	75	100	N1	-	-	-	-	-	-	KBS
8	LME 60 A UUOP AS	60	90	125	N1	-	-	-	-	-	-	KBS

Remark : 1. "AS" means bearings contain with grease, grease holes and fixing holes.

Remark	Technical supplement		
	Retainer(s)	Precision	Grease
	Steel - ×	Class 0 (JIS)	Alvania S2 -25°C ~ +120°C
	Polymid - ✓		
	Brass - ×		

Qualified Sub-contractor(s)	Since
KBS	2003
-	-
-	-

**LINEAR BALL BEARINGS**  
**SERIES LME..OP**

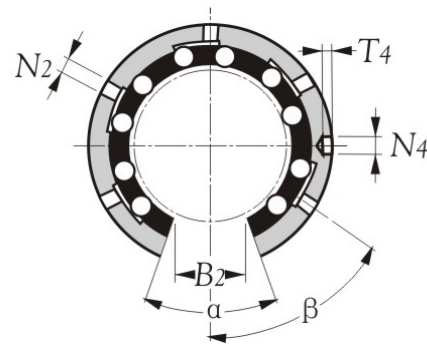
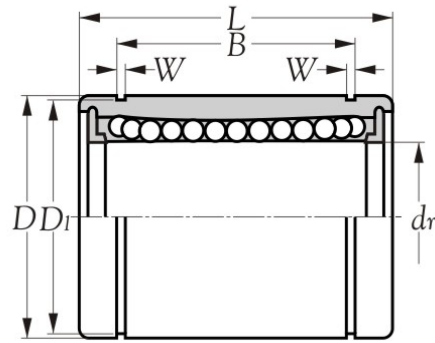

Items (8)	Data  Model nos.	Dimension			Packing method	Quantity  Min. order qty.	Delivery  Days	-		Compare percentages (%)	Production code(s)
		Bearing sizes						Unit price structure	Unit price structure		
		$d$	$D$	$L$							
		mm			Pcs		USD	USD			
1	LME 12 UUOP AS	12	22	32	N1	1,500	90	-	3.23	-	KBS
2	* LME 16 UUOP AS	16	26	36	N1	1,500	90	-	2.60	-	KBS
3	* LME 20 UUOP AS	20	32	45	N1	1,500	90	-	2.85	-	KBS
4	* LME 25 UUOP AS	25	40	58	N1	1,000	90	-	4.38	-	KBS
5	* LME 30 UUOP AS	30	47	68	N1	1,000	90	-	6.10	-	KBS
6	* LME 40 UUOP AS	40	62	80	N1	250	90	-	10.40	-	KBS
7	* LME 50 UUOP AS	50	75	100	N1	-	-	-	-	-	KBS
8	* LME 60 UUOP AS	60	90	125	N1	-	-	-	-	-	KBS

Remark : 1. "AS" means bearings contain with grease, grease holes and fixing holes.

Remark	Technical supplement		
	Retainer(s)	Precision	Grease
	Steel - <input type="checkbox"/>	Class 0 (JIS)	Alvania S2 -25°C ~ +120°C
	Polymid - <input checked="" type="checkbox"/>		
	Brass - <input type="checkbox"/>		

Qualified Sub-contractor(s)	Since
KBS	2003
-	-
-	-



**LINEAR BALL BEARINGS**  
**SERIES LME..OP**

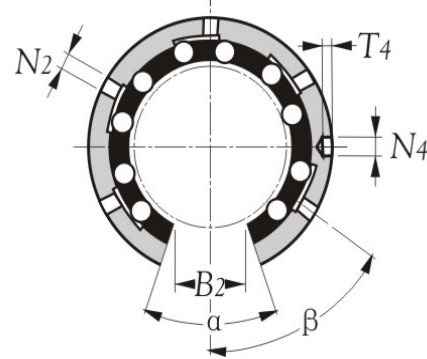
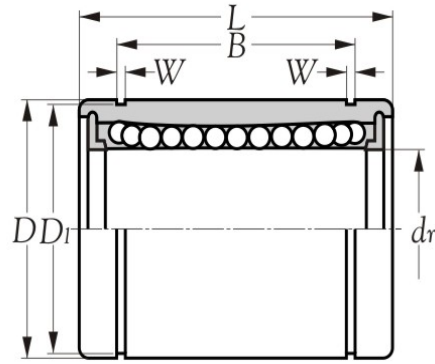

Items (8)	Data  Model nos.	Dimension			Packing method	Quantity  Min. order qty.	Delivery  Days	-		2014-09-01	Compare percentages (%)	Production code(s)
		Bearing sizes						Unit price structure	Unit price structure			
		d	D	L								
		mm				Pcs		USD	USD			
1	LME 12 A OP	12	22	32	N1	1,500	90	-	-	-	-	LOYS
2	LME 16 A OP	16	26	36	N1	1,500	90	-	-	-	-	LOYS
3	LME 20 A OP	20	32	45	N1	1,500	90	-	-	-	-	LOYS
4	LME 25 A OP	25	40	58	N1	1,000	90	-	-	-	-	LOYS
5	LME 30 A OP	30	47	68	N1	1,000	90	-	-	-	-	LOYS
6	LME 40 A OP	40	62	80	N1	250	90	-	-	-	-	LOYS
7	LME 50 A OP	50	75	100	N1	-	-	-	-	-	-	LOYS
8	LME 60 A OP	60	90	125	N1	-	-	-	-	-	-	LOYS

Remark : 1. "AS" means bearings contain with grease, grease holes and fixing holes.

Remark	Technical supplement		
	Retainer(s)	Precision	Grease
	Steel - <input type="checkbox"/>	Class 0 (JIS)	Alvania S2 -25°C ~ +120°C
	Polymid - <input checked="" type="checkbox"/>		
	Brass - <input type="checkbox"/>		

Qualified Sub-contractor(s)	Since
LOYS	2010
-	-
-	-

**LINEAR BALL BEARINGS**  
**SERIES LME..OP**

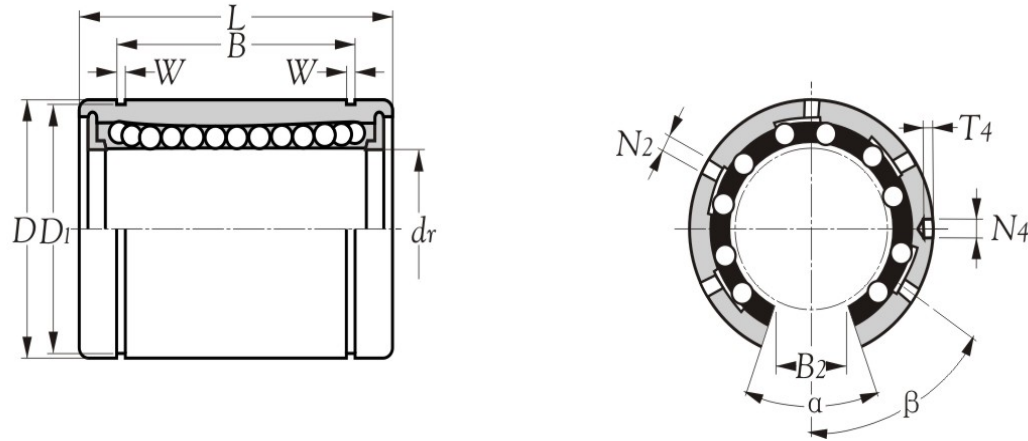

Items (8)	Data  Model nos.	Dimension			Packing method	Quantity  Min. order qty.	Delivery  Days	-		2014-09-01	Compare percentages (%)	Production code(s)
		Bearing sizes						Unit price structure	Unit price structure			
		d	D	L								
		mm				Pcs		USD	USD			
1	LME 12 OP AS	12	22	32	N1	1,500	90	-	-	-	-	LOYS
2	LME 16 OP AS	16	26	36	N1	1,500	90	-	-	-	-	LOYS
3	LME 20 OP AS	20	32	45	N1	1,500	90	-	-	-	-	LOYS
4	LME 25 OP AS	25	40	58	N1	1,000	90	-	-	-	-	LOYS
5	LME 30 OP AS	30	47	68	N1	1,000	90	-	-	-	-	LOYS
6	LME 40 OP AS	40	62	80	N1	250	90	-	-	-	-	LOYS
7	LME 50 OP AS	50	75	100	N1	-	-	-	-	-	-	LOYS
8	LME 60 OP AS	60	90	125	N1	-	-	-	-	-	-	LOYS

Remark : 1. "AS" means bearings contain with grease, grease holes and fixing holes.

Remark	Technical supplement		
	Retainer(s)	Precision	Grease
	Steel - ×	Class 0 (JIS)	Alvania S2 -25°C ~ +120°C
	Polymid - ✓		
	Brass - ×		

Qualified Sub-contractor(s)	Since
LOYS	2010
-	-
-	-

**LINEAR BALL BEARINGS**  
**SERIES LME..OP**

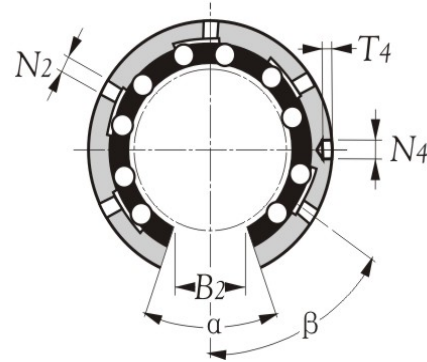
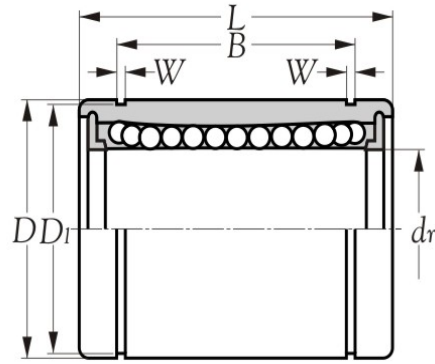

Items (8)	Data  Model nos.	Dimension			Packing method	Quantity  Min. order qty.	Delivery  Days	-		2014-09-01	Compare percentages (%)	Production code(s)
		Bearing sizes						Unit price structure	Unit price structure			
		d	D	L								
		mm				Pcs						
1	LME 12 A UUOP AS	12	22	32	N1	1,500	90	-	-	-	-	LOYS
2	LME 16 A UUOP AS	16	26	36	N1	1,500	90	-	-	-	-	LOYS
3	LME 20 A UUOP AS	20	32	45	N1	1,500	90	-	-	-	-	LOYS
4	LME 25 A UUOP AS	25	40	58	N1	1,000	90	-	-	-	-	LOYS
5	LME 30 A UUOP AS	30	47	68	N1	1,000	90	-	-	-	-	LOYS
6	LME 40 A UUOP AS	40	62	80	N1	250	90	-	-	-	-	LOYS
7	LME 50 A UUOP AS	50	75	100	N1	-	-	-	-	-	-	LOYS
8	LME 60 A UUOP AS	60	90	125	N1	-	-	-	-	-	-	LOYS

Remark : 1. "AS" means bearings contain with grease, grease holes and fixing holes.

Remark	Technical supplement		
	Retainer(s)	Precision	Grease
	Steel - ×	Class 0 (JIS)	Alvania S2 -25°C ~ +120°C
	Polymid - ✓		
	Brass - ×		

Qualified Sub-contractor(s)	Since
LOYS	2010
-	-
-	-

**LINEAR BALL BEARINGS**  
**SERIES LME..OP**

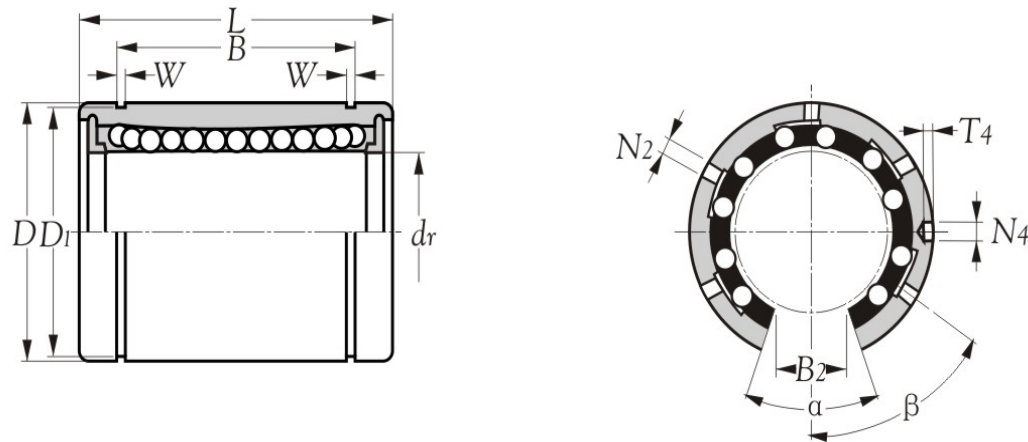

Items (8)	Data  Model nos.	Dimension			Packing method	Quantity  Min. order qty.	Delivery  Days	-		Compare percentages (%)	Production code(s)
		Bearing sizes						Unit price structure	Unit price structure		
		d	D	L							
		mm				Pcs		USD	USD		
1	LME 12 UUOP AS	12	22	32	N1	1,500	90	-	2.08	-	LOYS
2	* LME 16 UUOP AS	16	26	36	N1	1,500	90	-	2.26	-	LOYS
3	* LME 20 UUOP AS	20	32	45	N1	1,500	90	-	2.49	-	LOYS
4	* LME 25 UUOP AS	25	40	58	N1	1,000	90	-	3.83	-	LOYS
5	* LME 30 UUOP AS	30	47	68	N1	1,000	90	-	5.33	-	LOYS
6	* LME 40 UUOP AS	40	62	80	N1	250	90	-	9.06	-	LOYS
7	* LME 50 UUOP AS	50	75	100	N1	-	-	-	-	-	LOYS
8	* LME 60 UUOP AS	60	90	125	N1	-	-	-	-	-	LOYS

Remark : 1. "AS" means bearings contain with grease, grease holes and fixing holes.

Remark	Technical supplement		
	Retainer(s)	Precision	Grease
	Steel - ×	Class 0 (JIS)	Alvania S2 -25°C ~ +120°C
	Polymid - ✓		
	Brass - ×		

Qualified Sub-contractor(s)	Since
LOYS	2010
-	-
-	-

LINEAR BALL BEARINGS  
SERIES **LME..F**

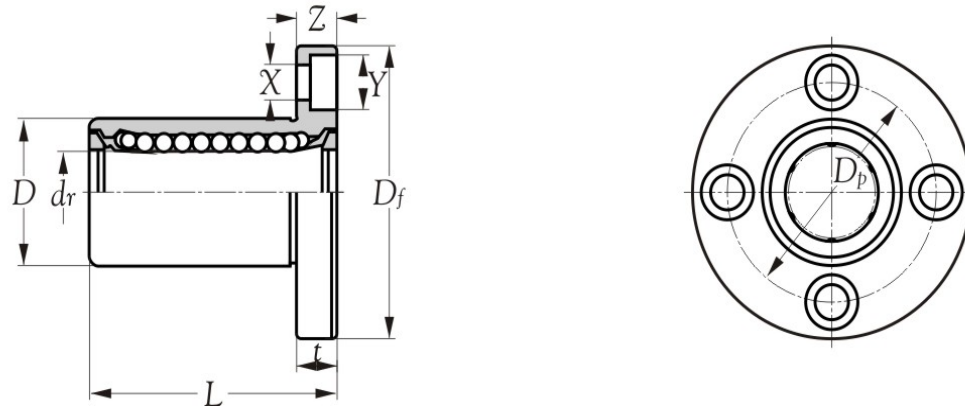

Items (9)	Data  Model nos.	Dimension			Packing method	Quantity  Min. order qty.	Delivery  Days	-		Compare percentages (%)	Production code(s)
		Bearing sizes						Unit price structure	2014-09-01 Unit price structure		
		d	D	L							
		mm				Pcs		USD	USD		
1	<b>LMEF 8</b>	8	16	25	N1	100	120	-	<b>2.76</b>	-	LOYS
2	<b>LMEF 12</b>	12	22	32	N1	100	120	-	<b>3.09</b>	-	LOYS
3	<b>LMEF 16</b>	16	26	36	N1	100	120	-	<b>3.65</b>	-	LOYS
4	<b>LMEF 20</b>	20	32	45	N1	100	120	-	<b>3.83</b>	-	LOYS
5	<b>LMEF 25</b>	25	40	58	N1	100	120	-	<b>5.14</b>	-	LOYS
6	<b>LMEF 30</b>	30	47	68	N1	100	120	-	<b>7.01</b>	-	LOYS
7	<b>LMEF 40</b>	40	62	80	N1	100	120	-	<b>12.55</b>	-	LOYS
8	<b>LMEF 50</b>	50	75	100	N1	100	120	-	<b>21.95</b>	-	LOYS
9	<b>LMEF 60</b>	60	90	125	N1	100	120	-	<b>28.83</b>	-	LOYS

Remark	Technical supplement		
	Retainer(s)	Precision	Grease
	Steel - <input type="checkbox"/>	Class 0 (JIS)	Alvania S2 -25°C ~ +120°C
	Polymid - <input checked="" type="checkbox"/>		
	Brass - <input type="checkbox"/>		

Qualified Sub-contractor(s)	Since
LOYS	2010
-	-
-	-

LINEAR BALL BEARINGS  
SERIES **LME..F**

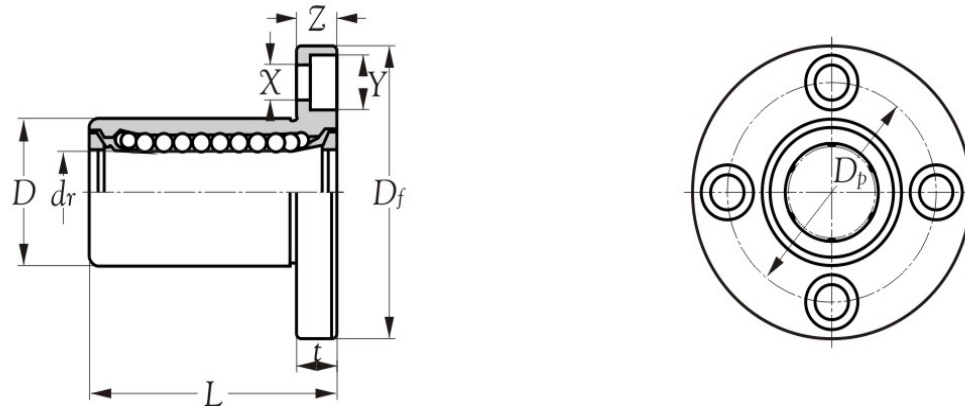

Items (9)	Data  Model nos.	Dimension			Packing method	Quantity  Min. order qty.	Delivery  Days	-		Compare percentages (%)	Production code(s)
		Bearing sizes						Unit price structure	2014-09-01 Unit price structure		
		d	D	L							
		mm				Pcs		USD	USD		
1	LMEF 8 UU	8	16	25	N1	100	120	-	2.76	-	LOYS
2	LMEF 12 UU	12	22	32	N1	100	120	-	3.09	-	LOYS
3	LMEF 16 UU	16	26	36	N1	100	120	-	3.65	-	LOYS
4	LMEF 20 UU	20	32	45	N1	100	120	-	3.83	-	LOYS
5	LMEF 25 UU	25	40	58	N1	100	120	-	5.14	-	LOYS
6	LMEF 30 UU	30	47	68	N1	100	120	-	7.01	-	LOYS
7	LMEF 40 UU	40	62	80	N1	100	120	-	12.55	-	LOYS
8	LMEF 50 UU	50	75	100	N1	100	120	-	21.95	-	LOYS
9	LMEF 60 UU	60	90	125	N1	100	120	-	28.83	-	LOYS

Remark	Technical supplement		
	Retainer(s)	Precision	Grease
	Steel - <input checked="" type="checkbox"/> Polymid - <input checked="" type="checkbox"/> Brass - <input checked="" type="checkbox"/>	Class 0 (JIS)	Alvania S2 -25°C ~ +120°C

Qualified Sub-contractor(s)	Since
LOYS	2010
-	-
-	-

**LINEAR BALL BEARINGS**  
**SERIES LME..K**

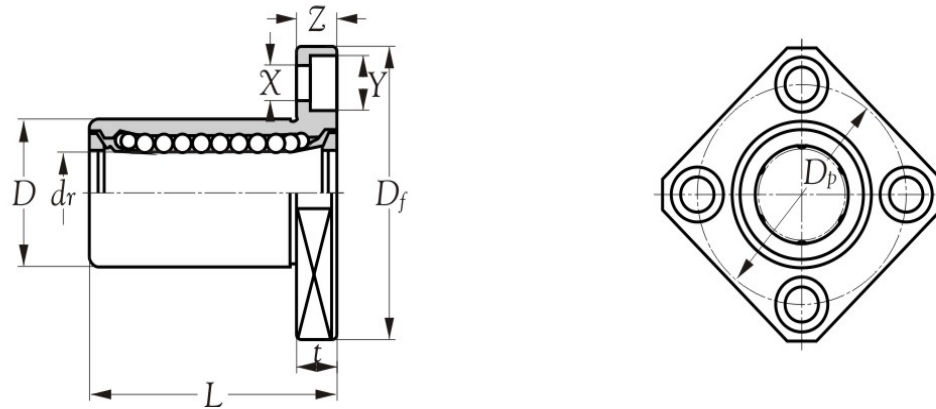

Items (9)	Data  Model nos.	Dimension			Packing method	Quantity  Min. order qty.	Delivery  Days	-	2014-09-01	-	Production code(s)			
		Bearing sizes										Unit price structure	Unit price structure	Compare percentages (%)
		d	D	L										
		mm				Pcs		USD	USD					
1	<b>LMEK 8</b>	8	16	25	N1	100	120	-	<b>3.04</b>	-	LOYS			
2	<b>LMEK 12</b>	12	22	32	N1	100	120	-	<b>3.40</b>	-	LOYS			
3	<b>LMEK 16</b>	16	26	36	N1	100	120	-	<b>3.93</b>	-	LOYS			
4	<b>LMEK 20</b>	20	32	45	N1	100	120	-	<b>4.19</b>	-	LOYS			
5	<b>LMEK 25</b>	25	40	58	N1	100	120	-	<b>5.55</b>	-	LOYS			
6	<b>LMEK 30</b>	30	47	68	N1	100	120	-	<b>7.39</b>	-	LOYS			
7	<b>LMEK 40</b>	40	62	80	N1	100	120	-	<b>13.85</b>	-	LOYS			
8	<b>LMEK 50</b>	50	75	100	N1	100	120	-	<b>22.84</b>	-	LOYS			
9	<b>LMEK 60</b>	60	90	125	N1	100	120	-	<b>31.13</b>	-	LOYS			

Remark	Technical supplement		
	Retainer(s)	Precision	Grease
	Steel - <input checked="" type="checkbox"/> Polymid - <input checked="" type="checkbox"/> Brass - <input checked="" type="checkbox"/>	Class 0 (JIS)	Alvania S2 -25°C~+120°C

Qualified Sub-contractor(s)	Since
LOYS	2010
-	-
-	-

**LINEAR BALL BEARINGS**  
**SERIES LME..K**

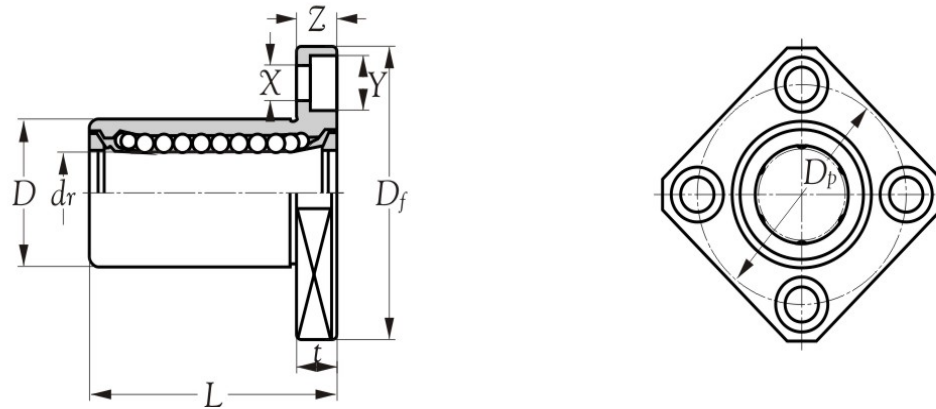

Items (9)	Data  Model nos.	Dimension			Packing method	Quantity  Min. order qty.	Delivery  Days	-	2014-09-01	Compare percentages (%)	Production code(s)		
		Bearing sizes										Unit price structure	Unit price structure
		d	D	L									
		mm				Pcs		USD	USD				
1	LMEK 8 UU	8	16	25	N1	100	120	-	3.04	-	LOYS		
2	LMEK 12 UU	12	22	32	N1	100	120	-	3.40	-	LOYS		
3	LMEK 16 UU	16	26	36	N1	100	120	-	3.93	-	LOYS		
4	LMEK 20 UU	20	32	45	N1	100	120	-	4.19	-	LOYS		
5	LMEK 25 UU	25	40	58	N1	100	120	-	5.55	-	LOYS		
6	LMEK 30 UU	30	47	68	N1	100	120	-	7.39	-	LOYS		
7	LMEK 40 UU	40	62	80	N1	100	120	-	13.85	-	LOYS		
8	LMEK 50 UU	50	75	100	N1	100	120	-	22.84	-	LOYS		
9	LMEK 60 UU	60	90	125	N1	100	120	-	31.13	-	LOYS		

Remark	Technical supplement							
	Retainer(s)	Precision	Grease					
	<table border="1"> <tr> <td>Steel -</td> <td>×</td> </tr> <tr> <td>Polymid -</td> <td>✓</td> </tr> <tr> <td>Brass -</td> <td>×</td> </tr> </table>	Steel -	×	Polymid -	✓	Brass -	×	Class 0 (JIS)
Steel -	×							
Polymid -	✓							
Brass -	×							

Qualified Sub-contractor(s)	Since
LOYS	2010
-	-
-	-



**SUPER BALL BUSHINGS**  
**SERIES LMES**

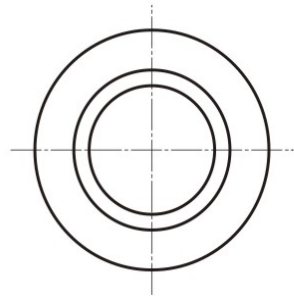

LMES..close, UU

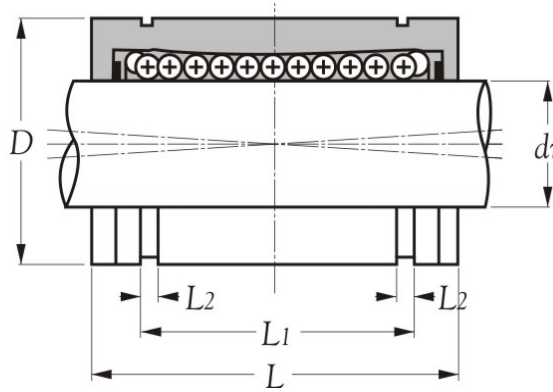

Items (8)	Data  Model nos.	Dimension			Packing method	Quantity  Min. order qty.  Pcs	Delivery  Days	Unit price structure  USD	2014-09-01  Unit price structure  USD	Compare percentages (%)	Production code(s)
		Bearing sizes									
		dr	D	L							
1	LMES 10	10	19	29	N1	-	-	-	-	-	-
2	LMES 12	12	22	32	N1	-	-	-	-	-	-
3	LMES 16	16	26	36	N1	-	-	-	-	-	-
4	LMES 20	20	32	45	N1	-	-	-	-	-	-
5	LMES 25	25	40	58	N1	-	-	-	-	-	-
6	LMES 30	30	47	68	N1	-	-	-	-	-	-
7	LMES 40	40	62	80	N1	-	-	-	-	-	-
8	LMES 50	50	75	100	N1	-	-	-	-	-	-

Remark	Technical supplement		
	Retainer(s)	Precision	Grease
	Steel - <input type="checkbox"/>	Class 0 (JIS)	Alvania S2 -25°C~+120°C
	Polymid - <input checked="" type="checkbox"/>		
	Brass - <input type="checkbox"/>		

Qualified Sub-contractor(s)	Since
-	-
-	-
-	-

**SUPER BALL BUSHINGS**  
**SERIES LMES**

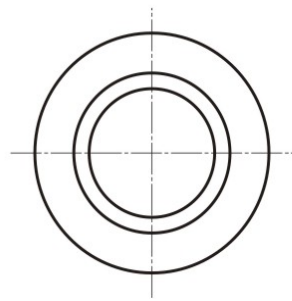

LMES..close, UU

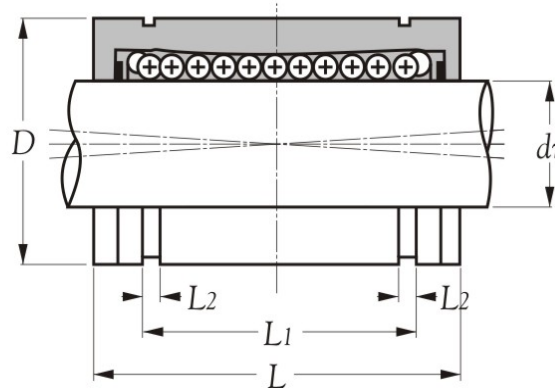

Items (8)	Data  Model nos.	Dimension			Packing method	Quantity  Min. order qty.  Pcs	Delivery  Days	-		2014-09-01  Unit price structure  USD	Compare percentages (%)	Production code(s)
		Bearing sizes						Unit price structure  USD	Unit price structure  USD			
		dr	D	L								
mm												
1	LMES 10 UU	10	19	29	N1	-	-	-	-	-	-	
2	LMES 12 UU	12	22	32	N1	-	-	-	-	-	-	
3	LMES 16 UU	16	26	36	N1	-	-	-	-	-	-	
4	LMES 20 UU	20	32	45	N1	-	-	-	-	-	-	
5	LMES 25 UU	25	40	58	N1	-	-	-	-	-	-	
6	LMES 30 UU	30	47	68	N1	-	-	-	-	-	-	
7	LMES 40 UU	40	62	80	N1	-	-	-	-	-	-	
8	LMES 50 UU	50	75	100	N1	-	-	-	-	-	-	

Remark	Technical supplement		
	Retainer(s)	Precision	Grease
	Steel - <input type="checkbox"/> Polymid - <input checked="" type="checkbox"/> Brass - <input type="checkbox"/>	Class 0 (JIS)	Alvania S2 -25°C~+120°C

Qualified Sub-contractor(s)	Since
-	-
-	-
-	-

**SUPER BALL BUSHINGS  
SERIES LMES..OP**

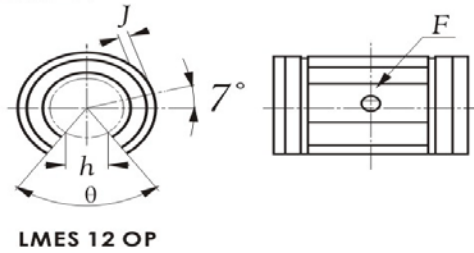

LMES 12 OP

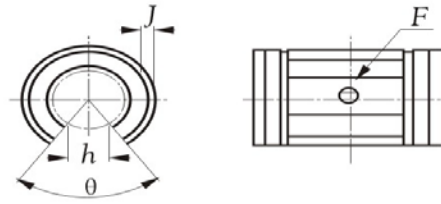

LMES 16 OP, LMES 20 OP

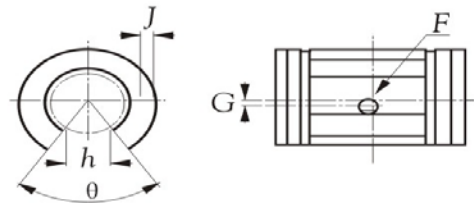

LMES 25 OP

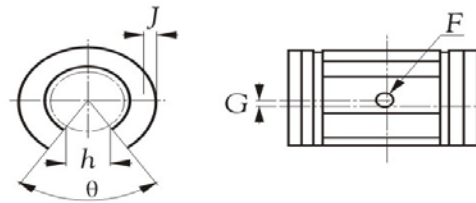

LMES 30 OP, LMES 40 OP, LMES 50 OP

Items (7)	Data  Model nos.	Dimension			Packing method	Quantity  Min. order qty.  Pcs	Delivery  Days	-	2014-08-01	Compare percentages (%)	Production code(s)
		dr	D	L				Unit price structure	Unit price structure		
								USD	USD		
1	LMES 12 OP	12	22	32	N1	-	-	-	-	-	-
2	LMES 16 OP	16	26	36	N1	-	-	-	-	-	-
3	LMES 20 OP	20	32	45	N1	-	-	-	-	-	-
4	LMES 25 OP	25	40	58	N1	-	-	-	-	-	-
5	LMES 30 OP	30	47	68	N1	-	-	-	-	-	-
6	LMES 40 OP	40	62	80	N1	-	-	-	-	-	-
7	LMES 50 OP	50	75	100	N1	-	-	-	-	-	-

Remark	Technical supplement		
	Retainer(s)	Precision	Grease
	Steel - <input type="checkbox"/> Polymid - <input checked="" type="checkbox"/> Brass - <input type="checkbox"/>	Class 0 (JIS)	Alvania S2 -25°C~+120°C

Qualified Sub-contractor(s)	Since
-	-
-	-
-	-

**SUPER BALL BUSHINGS  
SERIES LMES..OP**

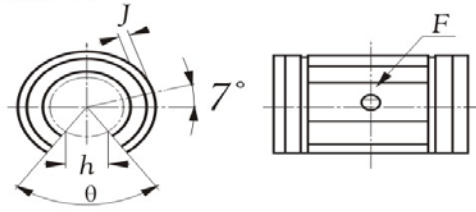

LMES 12 OP

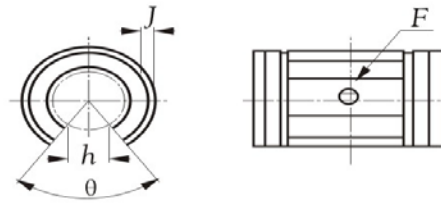

LMES 16 OP, LMES 20 OP

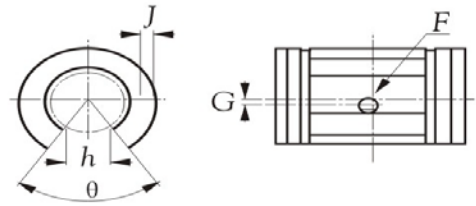

LMES 25 OP

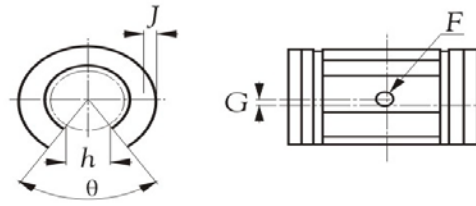

LMES 30 OP, LMES 40 OP, LMES 50 OP

Items (7)	Data  Model nos.	Dimension			Packing method	Quantity  Min. order qty.  Pcs	Delivery  Days	-	2014-09-01	Compare percentages (%)	Production code(s)		
		Bearing sizes										Unit price structure  USD	Unit price structure  USD
		dr	D	L									
		mm											
1	LMES 12 UUOP	12	22	32	N1	-	-	-	-	-	-		
2	LMES 16 UUOP	16	26	36	N1	-	-	-	-	-	-		
3	LMES 20 UUOP	20	32	45	N1	-	-	-	-	-	-		
4	LMES 25 UUOP	25	40	58	N1	-	-	-	-	-	-		
5	LMES 30 UUOP	30	47	68	N1	-	-	-	-	-	-		
6	LMES 40 UUOP	40	62	80	N1	-	-	-	-	-	-		
7	LMES 50 UUOP	50	75	100	N1	-	-	-	-	-	-		

<b>Remark</b>	Technical supplement		
	Retainer(s)	Precision	Grease
	Steel - <input type="checkbox"/>	Class 0 (JIS)	Alvania S2 -25°C~+120°C
	Polymid - <input checked="" type="checkbox"/>		
Brass - <input type="checkbox"/>			

Qualified Sub-contractor(s)	Since
-	-
-	-
-	-

LINEAR BALL BEARINGS

SERIES KH

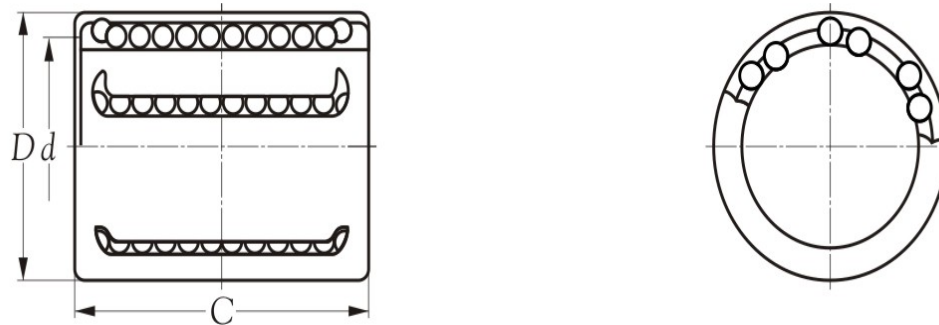

Items (22)	Data  Model nos.	Dimension			Packing method	Quantity  Min. order qty.	Delivery	-	2014-09-01	Compare percentages (%)	Production code(s)
		Bearing sizes									
		d	D	C							
		mm				Pcs	Days	USD	USD		
1	KH 0622 (WR) (10x1)	6	12	22	N2	-	-	-	2.03	-	KBS
2	* KH 0824 (WR) (2x1)	8	15	24	N2	2,000	90	-	1.86	-	KBS
3	* KH 1026 (WR) (2x1)	10	17	26	N2	2,000	90	-	1.88	-	KBS
4	* KH 1228 (WR) (2x1)	12	19	28	N2	3,000	90	-	1.91	-	KBS
5	* KH 1428 (WR) (2x1)	14	21	28	N2	2,000	90	-	1.98	-	KBS
6	* KH 1630 (WR)	16	24	30	N1	3,000	90	-	2.00	-	KBS
7	* KH 2030 (WR)	20	28	30	N1	3,000	90	-	2.10	-	KBS
8	* KH 2540 (WR)	25	35	40	N1	3,000	90	-	2.94	-	KBS
9	* KH 3050 (WR)	30	40	50	N1	3,000	90	-	4.35	-	KBS
10	* KH 4060 (WR)	40	52	60	N1	1,000	90	-	5.58	-	KBS
11	* KH 5070 (WR)	50	62	70	N1	500	90	-	7.84	-	KBS
12	KH 0622 PP (WR) (10x1)	6	12	22	N2	-	-	-	2.10	-	KBS
13	* KH 0824 PP (WR) (2x1)	8	15	24	N2	2,000	90	-	1.91	-	KBS
14	* KH 1026 PP (WR) (2x1)	10	17	26	N2	2,000	90	-	1.95	-	KBS
15	* KH 1228 PP (WR) (2x1)	12	19	28	N2	3,000	90	-	1.98	-	KBS
16	* KH 1428 PP (WR) (2x1)	14	21	28	N2	2,000	90	-	2.03	-	KBS
17	* KH 1630 PP (WR)	16	24	30	N1	3,000	90	-	2.06	-	KBS
18	* KH 2030 PP (WR)	20	28	30	N1	3,000	90	-	2.15	-	KBS
19	* KH 2540 PP (WR)	25	35	40	N1	3,000	90	-	3.05	-	KBS
20	* KH 3050 PP (WR)	30	40	50	N1	3,000	90	-	4.23	-	KBS
21	* KH 4060 PP (WR)	40	52	60	N1	1,000	90	-	5.74	-	KBS
22	* KH 5070 PP (WR)	50	62	70	N1	500	90	-	8.14	-	KBS

Remarks: With white color plastic cage.

Remark	Technical supplement		
	Cage(s)	Precision	Grease
	Steel - <input checked="" type="checkbox"/>	INA Standard	Alvania S2 -25°C~+120°C
	Polymid - <input checked="" type="checkbox"/>		
	Brass - <input checked="" type="checkbox"/>		

Qualified Sub-contractor(s)	Since
KBS	2003
-	-
-	-



# ALUMINIUM HOUSINGS & COMPLETE UNITS



ALUMINIUM HOUSINGS  
SERIES **FGWA**

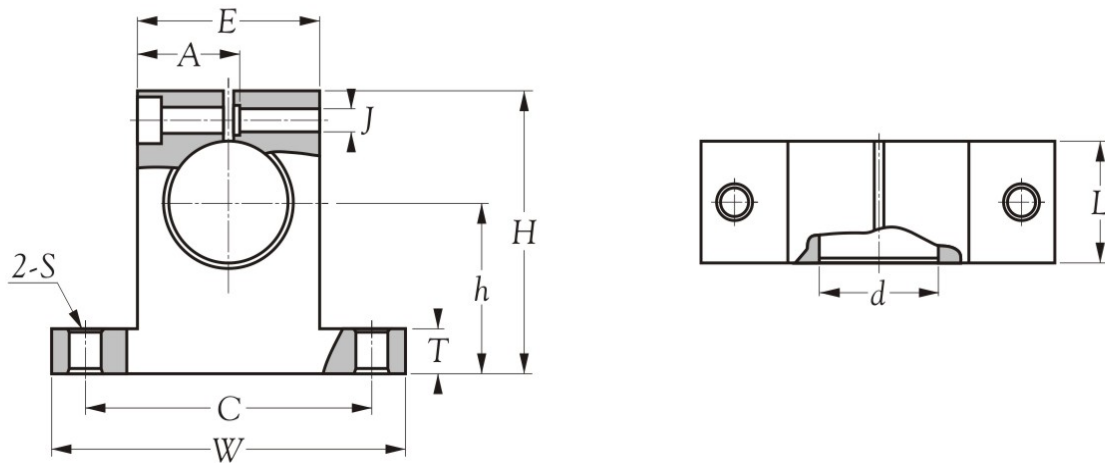

Items (6)	Data  Model nos.	Dimension			Packing method	Quantity  Min. order qty.  Pcs	Delivery  Days	Unit price structure  USD	2014-09-01 Unit price structure  USD	Compare percentages (%)	Production code(s)
		Bearing sizes									
		d	W	H							
1	* FGWA 12	12	42	35	N1	-	120	-	-	-	-
2	* FGWA 16	16	50	42	N1	-	120	-	-	-	-
3	* FGWA 20	20	60	50	N1	-	120	-	-	-	-
4	* FGWA 25	25	74	58	N1	-	120	-	-	-	-
5	* FGWA 30	28	84	68	N1	-	120	-	-	-	-
6	* FGWA 40	32	108	86	N1	-	120	-	-	-	-

Remark	Technical supplement		
	Retainer(s)	Precision	Grease
	Steel - <input checked="" type="checkbox"/>	Class (JIS)	Nil
	Polymid - <input checked="" type="checkbox"/>		
Brass - <input checked="" type="checkbox"/>			

Qualified Sub-contractor(s)	Since
-	-
-	-
-	-

ALUMINIUM HOUSINGS  
SERIES **SB..AS**

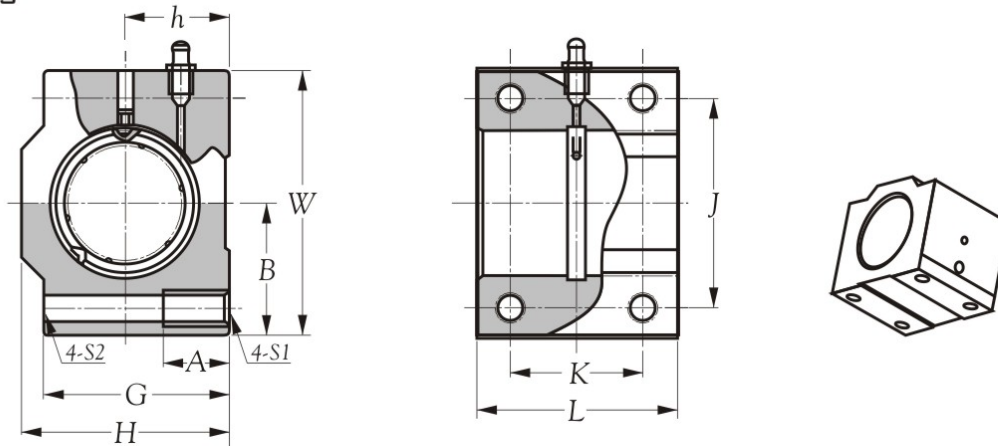

Items (5)	Data  Model nos.	Dimension			Packing method	Quantity  Min. order qty.  Pcs	Delivery  Days	-	2014-09-01	Compare percentages (%)	Production code(s)
		Bearing sizes						Unit price structure	Unit price structure		
		L	W	H				USD	USD		
1	* SB 16 AS	36	53	42	N1	500	120	-	4.11	-	LOYS
2	* SB 20 AS	45	60	50	N1	500	120	-	4.75	-	LOYS
3	SB 25 AS	58	78	60	N1	500	120	-	8.86	-	LOYS
4	* SB 30 AS	68	87	70	N1	200	120	-	11.15	-	LOYS
5	* SB 40 AS	80	108	90	N1	200	120	-	22.38	-	LOYS

Remark	Technical supplement		
	Cage(s)	Precision	Grease
	Steel - <input checked="" type="checkbox"/>	Class (JIS)	Alvania S2 -25°C ~ +120°C
	Polymid - <input checked="" type="checkbox"/>		
	Brass - <input checked="" type="checkbox"/>		

Qualified Sub-contractor(s)	Since
LOYS	2010
-	-
-	-



**ALUMINIUM HOUSINGS**  
**SERIES SB..AS**

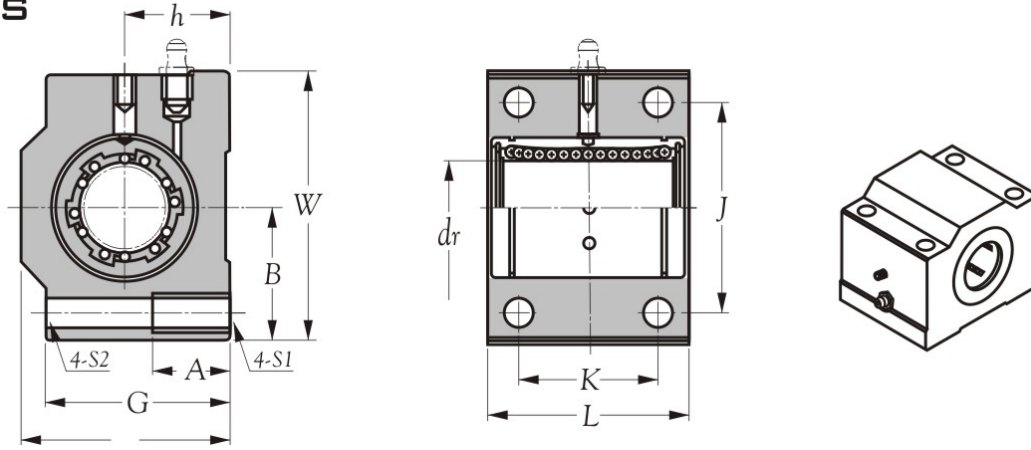

Items (5)	Data  Model nos.	Dimension			Packing method	Quantity  Min. order qty.  Pcs	Delivery  Days	-	2014-09-01	Compare percentages (%)	Production code(s)
		Bearing sizes						Unit price structure	Unit price structure		
		L	W	H				USD	USD		
		mm					USD	USD			
1	SB LME 16 UU AS	36	53	42	N1	500	120	-	5.88	-	LOYS
2	SB LME 20 UU AS	45	60	50	N1	500	120	-	6.85	-	LOYS
3	SB LME 25 UU AS	58	78	60	N1	500	120	-	11.95	-	LOYS
4	SB LME 30 UU AS	68	87	70	N1	200	120	-	15.38	-	LOYS
5	SB LME 40 UU AS	80	108	90	N1	200	120	-	38.73	-	LOYS

Remark	Technical supplement		
	Cage(s)	Precision	Grease
	Steel - <input checked="" type="checkbox"/>	Class (JIS)	Alvania S2 -25°C ~ +120°C
	Polymid - <input checked="" type="checkbox"/>		
	Brass - <input checked="" type="checkbox"/>		

Qualified Sub-contractor(s)	Since
LOYS	2010
-	-
-	-

ALUMINIUM HOUSINGS  
SERIES **SO..AS**

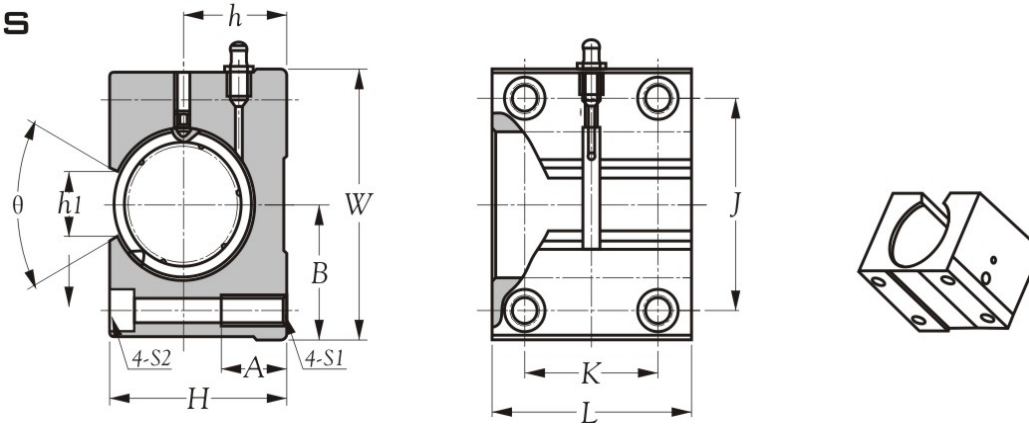

Items (5)	Data  Model nos.	Dimension			Packing method	Quantity  Min. order qty.  Pcs	Delivery  Days	-	2014-09-01	Compare percentages (%)	Production code(s)
		Bearing sizes						Unit price structure	Unit price structure		
		L	W	H				USD	USD		
1	* SO 16 AS	36	53	35	N1	500	120	-	4.06	-	LOYS
2	* SO 20 AS	45	60	42	N1	500	120	-	4.58	-	LOYS
3	* SO 25 AS	58	78	51	N1	500	120	-	8.76	-	LOYS
4	* SO 30 AS	68	87	60	N1	200	120	-	10.95	-	LOYS
5	* SO 40 AS	80	108	77	N1	200	120	-	21.80	-	LOYS

Remark	Technical supplement		
	Cage(s)	Precision	Grease
	Steel - <input checked="" type="checkbox"/>	Class (JIS)	Alvania S2 -25°C~+120°C
	Polymid - <input checked="" type="checkbox"/>		
	Brass - <input checked="" type="checkbox"/>		

Qualified Sub-contractor(s)	Since
LOYS	2010
-	-
-	-

ALUMINIUM HOUSINGS  
SERIES **SO..AS**

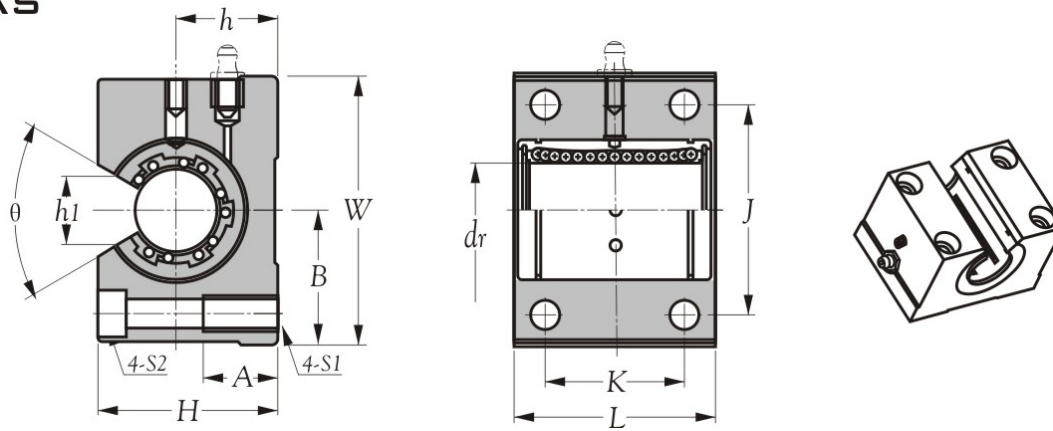

Items (5)	Data  Model nos.	Dimension			Packing method	Quantity  Min. order qty.  Pcs	Delivery  Days	-	2014-09-01	Compare percentages (%)	Production code(s)
		Bearing sizes									
		L	W	H							
		mm						Unit price structure  USD	Unit price structure  USD		
1	SO LME 16 UUOP AS	36	53	35	N1	500	120	-	6.56	-	LOYS
2	SO LME 20 UUOP AS	45	60	42	N1	500	120	-	7.31	-	LOYS
3	SO LME 25 UUOP AS	58	78	51	N1	500	120	-	12.95	-	LOYS
4	SO LME 30 UUOP AS	68	87	60	N1	200	120	-	16.81	-	LOYS
5	SO LME 40 UUOP AS	80	108	77	N1	200	120	-	31.75	-	LOYS

Remark	Technical supplement		
	Cage(s)	Precision	Grease
	Steel - <input checked="" type="checkbox"/>	Class (JIS)	Alvania S2 -25°C~+120°C
	Polymid - <input checked="" type="checkbox"/>		
	Brass - <input checked="" type="checkbox"/>		

Qualified Sub-contractor(s)	Since
LOYS	2010
-	-
-	-

**ALUMINIUM HOUSINGS  
SERIES S2B..N**

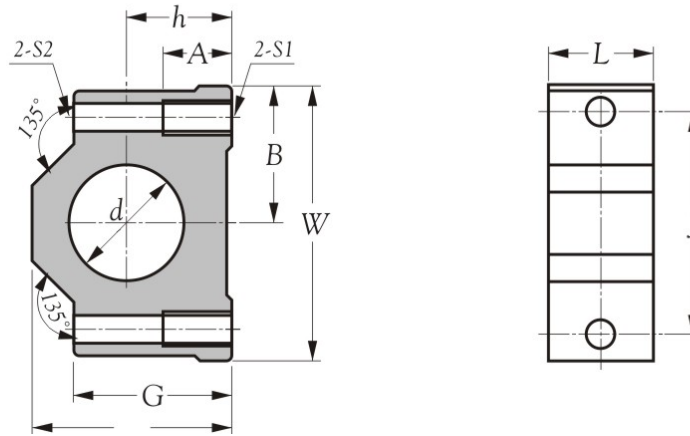

Items (7)	Data  Model nos.	Dimension			Packing method	Quantity  Min. order qty.	Delivery  Days	Unit price structure  USD	2014-09-01	Compare percentages (%)	Production code(s)
		L	W	H					Unit price structure  USD		
1	S2B 12 N	20	52	38	N1	500	120	-	2.88	-	LOYS
2	* S2B 16 N	22	56	40	N1	500	120	-	3.75	-	LOYS
3	* S2B 20 N	28	70	50	N1	500	120	-	4.33	-	LOYS
4	* S2B 25 N	40	80	60	N1	500	120	-	8.06	-	LOYS
5	* S2B 30 N	48	88	70	N1	200	120	-	11.34	-	LOYS
6	* S2B 40 N	56	108	85	N1	200	120	-	20.35	-	LOYS
7	S2B 50 N	72	135	102	N1	200	120	-	46.73	-	LOYS

Remark	Technical supplement		
	Cage(s)	Precision	Grease
	Steel - <input checked="" type="checkbox"/>	Class (JIS)	Alvania S2 -25°C~+120°C
	Polymid - <input checked="" type="checkbox"/>		
	Brass - <input checked="" type="checkbox"/>		

Qualified Sub-contractor(s)	Since
LOYS	2010
-	-
-	-

ALUMINIUM HOUSINGS  
SERIES **S2B..N**

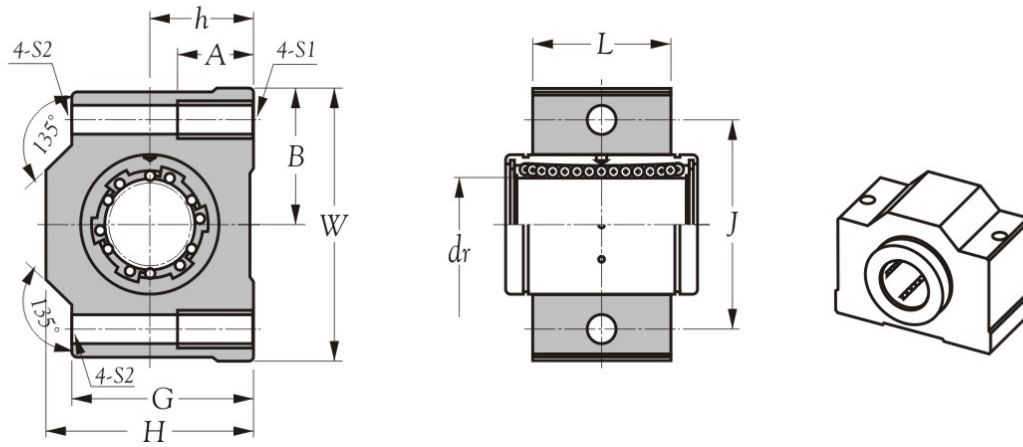

Items (7)	Data  Model nos.	Dimension			Packing method	Quantity  Min. order qty.  Pcs	Delivery  Days	Unit price structure  USD	2014-09-01  Unit price structure  USD	Compare percentages (%)	Production code(s)
		Bearing sizes									
		L	W	H							
1	S2B 12 N+LME 12 UU AS	20	52	38	N1	500	120	-	4.50	-	LOYS
2	S2B 16 N+LME 16 UU AS	22	56	40	N1	500	120	-	5.51	-	LOYS
3	* S2B 20 N+LME 20 UU AS	28	70	50	N1	500	120	-	6.41	-	LOYS
4	* S2B 25 N+LME 25 UU AS	40	80	60	N1	500	120	-	11.14	-	LOYS
5	* S2B 30 N+LME 30 UU AS	48	88	70	N1	200	120	-	15.56	-	LOYS
6	S2B 40 N+LME 40 UU AS	56	108	85	N1	200	120	-	28.05	-	LOYS
7	S2B 50 N+LME 50 UU AS	72	135	102	N1	200	120	-	63.10	-	LOYS

Remark	Technical supplement		
	Cage(s)	Precision	Grease
	Steel - <input checked="" type="checkbox"/> Polymid - <input checked="" type="checkbox"/> Brass - <input checked="" type="checkbox"/>	Class (JIS)	Alvania S2 -25°C~+120°C

Qualified Sub-contractor(s)	Since
LOYS	2010
-	-
-	-

**ALUMINIUM HOUSINGS**  
**SERIES SBT..AS**

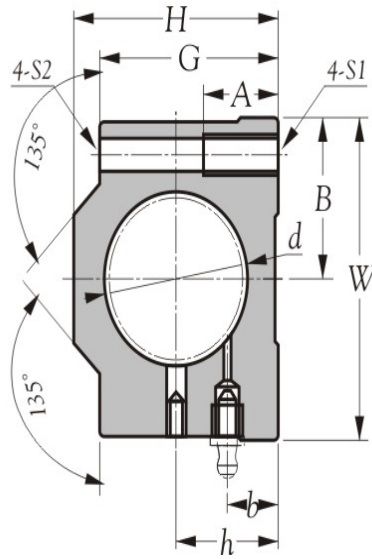

Items (7)	Data  Model nos.	Dimension			Packing method	Quantity  Min. order qty.	Delivery  Days	Unit price structure  USD	2014-09-01  Unit price structure  USD	Compare percentages (%)	Production code(s)
		Bearing sizes									
		L	W	H							
		mm				Pcs					
1	SBT 12 AS	70	43	35	N1	500	120	-	7.75	-	LOYS
2	SBT 16 AS	78	53	42	N1	500	120	-	8.58	-	LOYS
3	* SBT 20 AS	96	60	50	N1	500	120	-	9.70	-	LOYS
4	* SBT 25 AS	122	78	60	N1	500	120	-	19.39	-	LOYS
5	* SBT 30 AS	142	87	70	N1	200	120	-	24.38	-	LOYS
6	* SBT 40 AS	166	108	90	N1	200	120	-	44.88	-	LOYS
7	SBT 50 AS	212	132	101	N1	200	120	-	92.80	-	LOYS

<b>Remark</b>	Technical supplement		
	Cage(s)	Precision	Grease
	Steel - <input checked="" type="checkbox"/>	Class (JIS)	Alvania S2 -25°C~+120°C
	Polymid - <input checked="" type="checkbox"/>		
Brass - <input checked="" type="checkbox"/>			

Qualified Sub-contractor(s)	Since
LOYS	2010
-	-
-	-

**ALUMINIUM HOUSINGS**  
**SERIES SBT..AS**

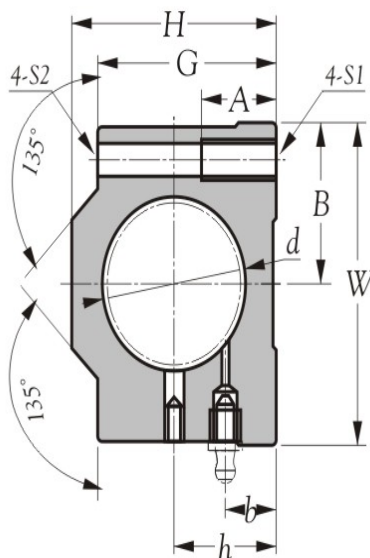

Items (7)	Data  Model nos.	Dimension			Packing method	Quantity  Min. order qty.  Pcs	Delivery  Days	Unit price structure  USD	2014-09-01  Unit price structure  USD	Compare percentages (%)	Production code(s)
		Bearing sizes									
		L	W	H							
1	SBT 12 AS + LME 12 UU AS (2x1)	70	43	35.0	N2	500	120	-	11.03	-	LOYS
2	SBT 16 AS + LME 16 UU AS (2x1)	78	53	42.0	N2	500	120	-	12.10	-	LOYS
3	SBT 20 AS + LME 20 UU AS (2x1)	96	60	50.0	N2	500	120	-	13.89	-	LOYS
4	SBT 25 AS + LME 25 UU AS (2x1)	122	78	60.0	N2	500	120	-	25.53	-	LOYS
5	SBT 30 AS + LME 30 UU AS (2x1)	142	87	70.0	N2	200	120	-	32.81	-	LOYS
6	SBT 40 AS + LME 40 UU AS (2x1)	166	108	90.0	N2	200	120	-	60.31	-	LOYS
7	SBT 50 AS + LME 50 UU AS (2x1)	212	132	101.0	N2	200	120	-	125.51	-	LOYS

<b>Remark</b>	Technical supplement		
	Cage(s)	Precision	Grease
	Steel - <input checked="" type="checkbox"/>	Class (JIS)	Alvania S2 -25°C~+120°C
	Polymid - <input checked="" type="checkbox"/>		
Brass - <input checked="" type="checkbox"/>			

Qualified Sub-contractor(s)	Since
LOYS	2010
-	-
-	-



# TRACK ROLLER BEARINGS





TRACK ROLLER BEARINGS DOUBLE ROW  
SERIES LR..NPP; LR..RRU

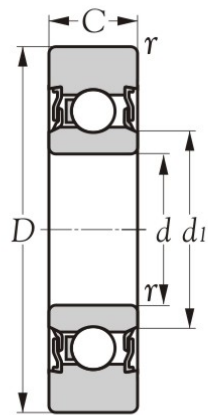

**NPP**

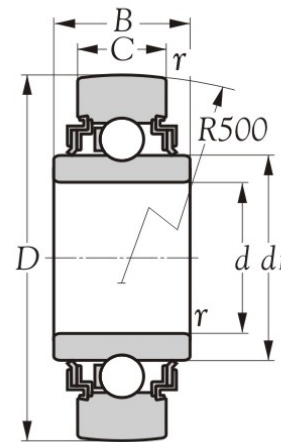

**RRU**

Items (11)	Data  Model nos.	Dimension			Packing method	Quantity  Min. order qty.	Delivery  Days	-	2014-09-01	Compare percentages (%)	Production code(s)		
		Bearing sizes										Unit price structure	Unit price structure
		d	D	C									
		mm				Pcs							
1	* LR 200 NPP	10	32	9	N1	900	120	-	1.34	-	WL		
2	* LR 201 NPP	12	35	10	N1	800	120	-	1.45	-	WL		
3	* LR 202 NPP	15	40	11	N1	700	120	-	1.66	-	WL		
4	* LR 203 NPP	17	47	12	N1	700	120	-	1.90	-	WL		
5	* LR 204 NPP	20	52	14	N1	500	120	-	2.38	-	WL		
6	* LR 205 NPP	25	62	15	N1	400	120	-	2.94	-	WL		
7	* LR 206 NPP	30	72	16	N1	300	120	-	3.70	-	WL		
8	* LR 207 NPP	35	80	17	N1	250	120	-	4.55	-	WL		
9	* LR 209 NPP	45	90	19	N1	190	120	-	6.29	-	WL		
10	* LR 201 RRU	12	35	10	N1	600	120	-	1.59	-	WL		
11	* LR 202 RRU	15	40	11	N1	600	120	-	1.86	-	WL		

<b>Remark</b>	Technical supplement	Precision	Grease
	Cage(s)		
	Steel - ✓	Class 0 (JIS)	Alvania S2 -25°C~+120°C
	Polymid - ✗		
Brass - ✗			

Qualified Sub-contractor(s)	Since
WL	2005
-	-
-	-

TRACK ROLLER BEARINGS DOUBLE ROW  
SERIES LR 50..

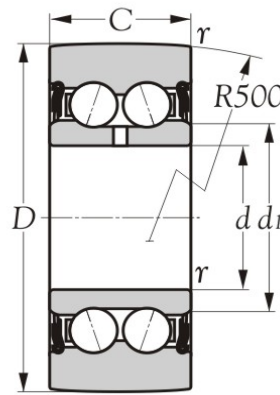

Type LR 50..NPPU  
( Light-contact, double seals )

Items (12)	Data  Model nos.	Dimension			Packing method	Quantity  Min. order qty.  Pcs	Delivery  Days	-		2014-09-01  Unit price structure  USD	Compare percentages (%)	Production code(s)
		Bearing sizes						Unit price structure  USD	Unit price structure  USD			
		d	D	C								
		mm										
1	LR 50/5 NPP	5	17	7	N1	1,000	90	-	3.55	-	WL	
2	LR 50/6 NPP	6	19	9	N1	1,000	90	-	3.55	-	WL	
3	LR 50/7 NPP	7	22	10	N1	1,000	90	-	3.55	-	WL	
4	LR 50/8 NPP	8	24	11	N1	1,000	90	-	4.09	-	WL	
5	LR 5000 NPPU	10	28	12	N1	1,000	90	-	4.64	-	WL	
6	LR 5001 NPPU	12	30	12	N1	1,000	90	-	5.28	-	WL	
7	LR 5002 NPPU	15	35	13	N1	1,000	90	-	5.86	-	WL	
8	LR 5003 NPPU	17	40	14	N1	1,000	90	-	7.03	-	WL	
9	LR 5004 NPPU	20	47	16	N1	1,000	90	-	8.21	-	WL	
10	LR 5005 NPPU	25	52	16	N1	1,000	90	-	9.68	-	WL	
11	LR 5006 NPPU	30	62	19	N1	1,000	90	-	11.74	-	WL	
12	LR 5007 NPPU	35	68	20	N1	1,000	90	-	15.84	-	WL	

<b>Remark</b>	Technical supplement		
	Cage(s)	Precision	Grease
	Steel - <input type="checkbox"/>	Class 0 (JIS)	Alvania S2 -25°C~+120°C
	Polymid - <input checked="" type="checkbox"/>		
Brass - <input type="checkbox"/>			

Qualified Sub-contractor(s)	Since
WL	2005
-	-
-	-

TRACK ROLLER BEARINGS DOUBLE ROW  
SERIES LR 52..NPPU; LR 52..KDD

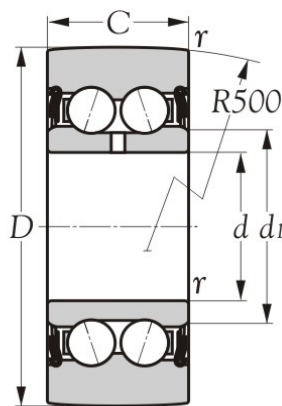

NPPU

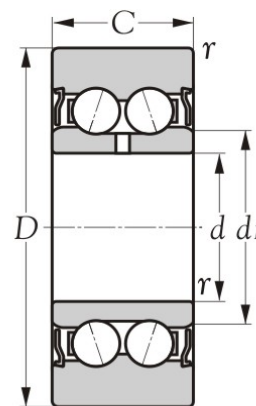

KDD

Items (18)	Data  Model nos.	Dimension			Packing method	Quantity  Min. order qty.	Delivery  Days	-	2014-09-01	Compare percentages (%)	Production code(s)		
		Bearing sizes										Unit price structure	Unit price structure
		d	D	C									
		mm				Pcs							
1	* LR 5200 NPPU	10	32	14	N1	250	90	-	3.78	-	WL		
2	* LR 5201 NPPU	12	35	15.9	N1	250	90	-	4.16	-	WL		
3	* LR 5202 NPPU	15	40	15.9	N1	200	90	-	4.60	-	WL		
4	* LR 5203 NPPU	17	47	17.5	N1	190	90	-	5.04	-	WL		
5	* LR 5204 NPPU	20	52	20.6	N1	180	90	-	5.69	-	WL		
6	* LR 5205 NPPU	25	62	20.6	N1	170	90	-	5.69	-	WL		
7	* LR 5206 NPPU	30	72	23.8	N1	120	90	-	7.83	-	WL		
8	* LR 5207 NPPU	35	80	27	N1	100	90	-	9.60	-	WL		
9	* LR 5208 NPPU	40	85	30.2	N1	80	90	-	12.28	-	WL		
10	* LR 5200 KDD	10	32	14	N1	250	90	-	3.70	-	WL		
11	* LR 5201 KDD	12	35	15.9	N1	250	90	-	3.98	-	WL		
12	* LR 5202 KDD	15	40	15.9	N1	250	90	-	4.43	-	WL		
13	* LR 5203 KDD	17	47	17.5	N1	190	90	-	4.85	-	WL		
14	* LR 5204 KDD	20	52	20.6	N1	190	90	-	5.20	-	WL		
15	* LR 5205 KDD	25	62	20.6	N1	180	90	-	5.50	-	WL		
16	* LR 5206 KDD	30	72	23.8	N1	130	90	-	7.61	-	WL		
17	* LR 5207 KDD	35	80	27	N1	110	90	-	9.29	-	WL		
18	* LR 5208 KDD	40	85	30.2	N1	90	90	-	12.00	-	WL		

Remark	Technical supplement		
	Cage(s)	Precision	Grease
	Steel - <input checked="" type="checkbox"/>	Class 0 (JIS)	Alvania S2 -25°C~+120°C
	Polymid - <input checked="" type="checkbox"/>		
	Brass - <input checked="" type="checkbox"/>		

Qualified Sub-contractor(s)	Since
WL	2005
-	-
-	-

TRACK ROLLER BEARINGS DOUBLE ROW  
SERIES LR 53.. NPPU

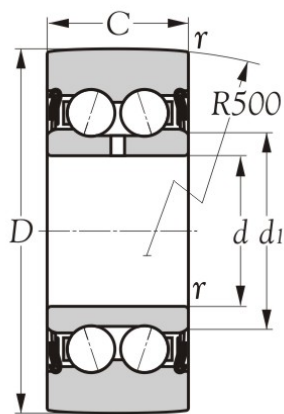

NPPU

Items (6)	Data  Model nos.	Dimension			Packing method	Quantity  Min. order qty.  Pcs	Delivery  Days	-		Compare percentages (%)	Production code(s)
		Bearing sizes						Unit price structure	Unit price structure		
		d	D	C							
mm			USD	USD							
1	* LR 5303 NPPU	17	52	22.2	N1	170	90	-	5.69	-	WL
2	* LR 5304 NPPU	20	62	22.2	N1	150	90	-	6.41	-	WL
3	* LR 5305 NPPU	25	72	25.4	N1	120	90	-	8.70	-	WL
4	* LR 5306 NPPU	30	80	30.2	N1	100	90	-	10.20	-	WL
5	* LR 5307 NPPU	35	90	34.9	N1	70	90	-	14.96	-	WL
6	* LR 5308 NPPU	40	100	36.5	N1	60	90	-	17.84	-	WL

Remark	Technical supplement		Precision	Grease
	Cage(s)			
	Steel -	×	Class 0 (JIS)	Alvania S2 -25°C ~ +120°C
	Polymid -	✓		
	Brass -	×		

Qualified Sub-contractor(s)	Since
WL	2005
-	.
-	-

TRACK ROLLER BEARINGS DOUBLE ROW  
SERIES **LFR..2RS; LFR..2Z**

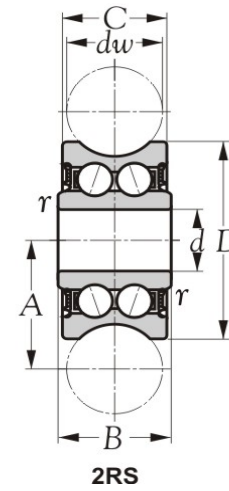
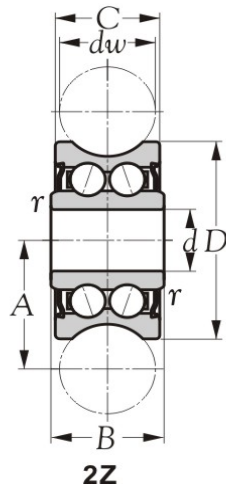

Items (18)	Data  Model nos.	Dimension			Packing method	Quantity  Min. order qty.	Delivery  Days	-		Compare percentages (%)	Production code(s)
		Bearing sizes						Unit price structure	2014-09-01 Unit price structure		
		d	D	C							
		mm				Pcs		USD	USD		
1	LFR 50/4-4 ZZ (5x1)	4	13	7	N2	300	90	-	3.20	-	WL
2	* LFR 50/5-4 ZZ (5x1)	5	16	8	N2	300	90	-	3.30	-	WL
3	* LFR 50/5-6 ZZ (5x1)	5	17	8	N2	300	90	-	3.30	-	WL
4	* LFR 50/8-6 ZZ	8	24	11	N1	300	90	-	3.45	-	WL
5	* LFR 5201-10 ZZ	12	35	15.9	N1	250	90	-	3.91	-	WL
6	* LFR 5301-10 ZZ	12	42	19	N1	250	90	-	5.10	-	WL
7	* LFR 5302-10 ZZ	15	47	19	N1	200	90	-	5.69	-	WL
8	* LFR 5201-12 ZZ	12	35	15.9	N1	250	90	-	3.91	-	WL
9	* LFR 5201-14 ZZ	12	39.9	20	N1	250	90	-	3.91	-	WL
10	* LFR 5204-16 ZZ	20	52	22.6	N1	180	90	-	5.99	-	WL
11	* LFR 5206-20 ZZ	25	72	25.8	N1	130	90	-	9.60	-	WL
12	* LFR 5206-25 ZZ	25	72	25.8	N1	130	90	-	9.60	-	WL
13	* LFR 5207-30 ZZ	30	80	29	N1	110	90	-	11.15	-	WL
14	* LFR 5208-40 ZZ	40	98	38	N1	80	90	-	18.60	-	WL
15	LFR 5308-50 ZZ	40	110	46	N1	60	90	-	19.49	-	WL
16	LFR 50/4-4 2RS (5x1)	4	13	7	N2	300	90	-	3.30	-	WL
17	* LFR 50/5-4 2RS (5x1)	5	16	8	N2	300	90	-	3.30	-	WL
18	* LFR 50/5-6 2RS (5x1)	5	17	8	N2	300	90	-	3.30	-	WL

Remark	Technical supplement		
	Cage(s)	Precision	Grease
	Steel - <input checked="" type="checkbox"/>	Class 0 (JIS)	Alvania S2 -25°C~+120°C
	Polymid - <input checked="" type="checkbox"/>		
	Brass - <input checked="" type="checkbox"/>		

Qualified Sub-contractor(s)	Since
WL	2005
-	-
-	-

TRACK ROLLER BEARINGS DOUBLE ROW  
SERIES **LFR..2RS; LFR..2Z**

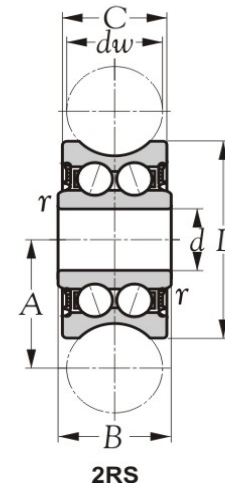
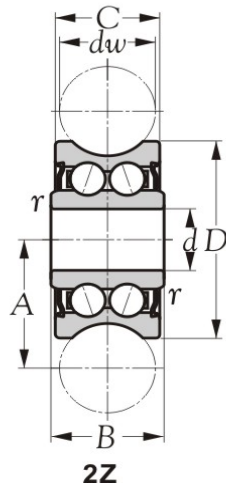

Items (12)	Data  Model nos.	Dimension			Packing method	Quantity  Min. order qty.	Delivery  Days	-		Compare percentages (%)	Production code(s)
		Bearing sizes						Unit price structure	2014-09-01 Unit price structure		
		d	D	C							
		mm				Pcs		USD	USD		
19	* LFR 50/8-6 2RS	8	24	11	N1	300	90	-	3.45	-	WL
20	* LFR 5201-10 2RS	12	35	15.9	N1	250	90	-	3.91	-	WL
21	* LFR 5301-10 2RS	12	42	19	N1	250	90	-	5.10	-	WL
22	* LFR 5302-10 2RS	15	47	19	N1	200	90	-	5.69	-	WL
23	* LFR 5201-12 2RS	12	35	15.9	N1	250	90	-	3.91	-	WL
24	* LFR 5201-14 2RS	12	39.9	20	N1	250	90	-	4.50	-	WL
25	* LFR 5204-16 2RS	20	52	22.6	N1	180	90	-	5.99	-	WL
26	* LFR 5206-20 2RS	25	72	25.8	N1	130	90	-	9.60	-	WL
27	* LFR 5206-25 2RS	25	72	25.8	N1	130	90	-	9.60	-	WL
28	* LFR 5207-30 2RS	30	80	29	N1	110	90	-	12.00	-	WL
29	* LFR 5208-40 2RS	40	98	38	N1	80	90	-	18.58	-	WL
30	LFR 5308-50 2RS	40	110	46	N1	60	90	-	19.48	-	WL

Remark	Technical supplement		
	Cage(s)	Precision	Grease
	Steel - <input type="checkbox"/>	Class 0 (JIS)	Alvania S2 -25°C~+120°C
	Polymid - <input checked="" type="checkbox"/>		
Brass - <input type="checkbox"/>			

Qualified Sub-contractor(s)	Since
WL	2005
-	-
-	-

**TRACK ROLLER BEARINGS DOUBLE ROW  
SERIES RC..; RE..**

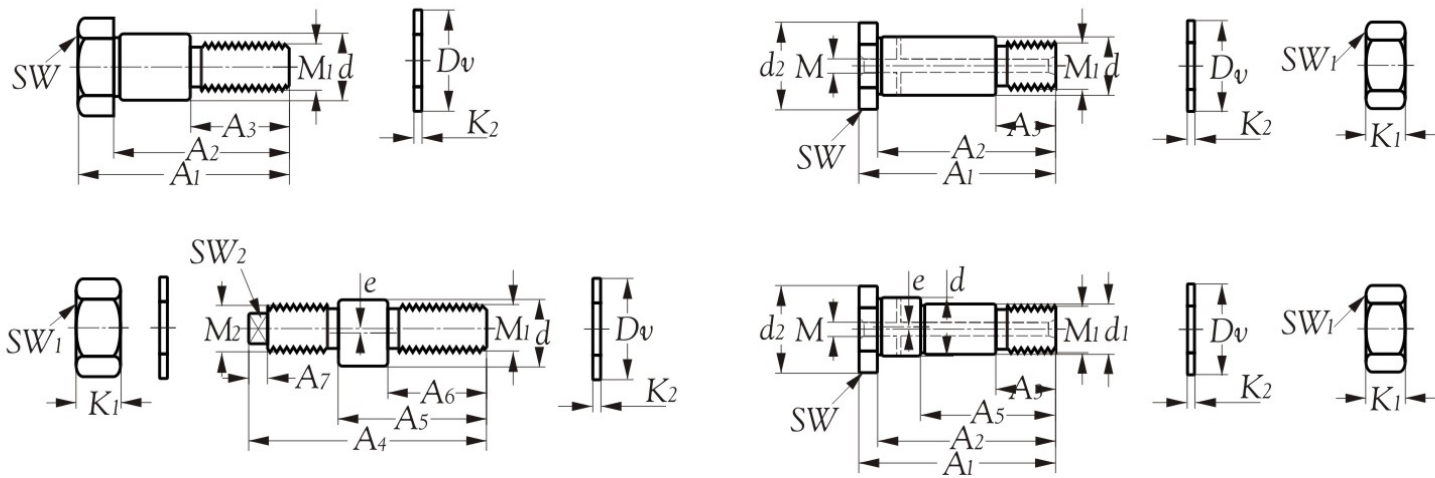

Items (11)	Data	Dimension			Packing method	Quantity Min. order qty.	Delivery Days	Unit price structure USD	2014-09-01 Unit price structure USD	Compare percentages (%)	Production code(s)
	Model nos.	Bearing sizes									
		d	D	C							
		mm				Pcs		USD	USD		
1	RC 5	-	-	-	N1	-	-	-	-	-	-
2	RC 8	-	-	-	N1	-	-	-	-	-	-
3	RC 12	-	-	-	N1	-	-	-	-	-	-
4	RC 12 / M12	-	-	-	N1	-	-	-	-	-	-
5	RC 15	-	-	-	N1	-	-	-	-	-	-
6	RC 12x45 - A1	-	-	-	N1	-	-	-	-	-	-
7	RC 20x67 - A1	-	-	-	N1	-	-	-	-	-	-
8	RC 25x82 - A1	-	-	-	N1	-	-	-	-	-	-
9	RC 30x95 - A1	-	-	-	N1	-	-	-	-	-	-
10	RC 40x107 - A1	-	-	-	N1	-	-	-	-	-	-
11	RC 40x115 - A1	-	-	-	N1	-	-	-	-	-	-

<b>Remark</b>	Technical supplement	Precision	Grease
	Cage(s)		
	Steel - X	Nil	Nil
	Polymid - X		
Brass - X			

Qualified Sub-contractor(s)	Since
-	-
-	-
-	-

**TRACK ROLLER BEARINGS DOUBLE ROW  
SERIES RC..; RE..**

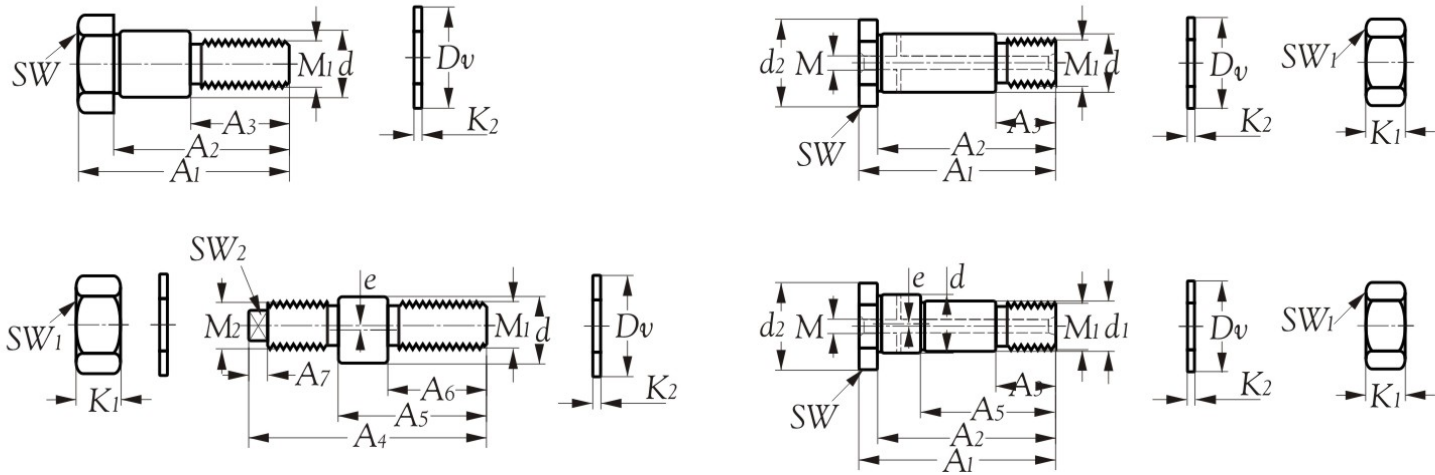

Items (11)	Data  Model nos.	Dimension			Packing method	Quantity  Min. order qty.	Delivery  Days	2014-09-01		Compare percentages (%)	Production code(s)
		Bearing sizes						Unit price structure	Unit price structure		
		d	D	C							
mm			Pcs	USD	USD						
1	RE 5 - 05	-	-	-	N1	-	-	-	-	-	-
2	RE 8 - 1	-	-	-	N1	-	-	-	-	-	-
3	RE 12 - 1	-	-	-	N1	-	-	-	-	-	-
4	RE 12 - 1 / M12	-	-	-	N1	-	-	-	-	-	-
5	RE 15 - 1	-	-	-	N1	-	-	-	-	-	-
6	RE 12x45 - A1	-	-	-	N1	-	-	-	-	-	-
7	RE 20x67 - A1	-	-	-	N1	-	-	-	-	-	-
8	RE 25x82 - A1	-	-	-	N1	-	-	-	-	-	-
9	RE 30x95 - A1	-	-	-	N1	-	-	-	-	-	-
10	RE 40x107 - A1	-	-	-	N1	-	-	-	-	-	-
11	RE 40x115 - A1	-	-	-	N1	-	-	-	-	-	-

<b>Remark</b>	Technical supplement		
	Cage(s)	Precision	Grease
	Steel - <input checked="" type="checkbox"/>	Nil	Nil
	Polymid - <input checked="" type="checkbox"/>		
Brass - <input checked="" type="checkbox"/>			

Qualified Sub-contractor(s)	Since
-	-
-	-
-	-



TRACK ROLLER BEARINGS DOUBLE ROW  
SERIES **RV**

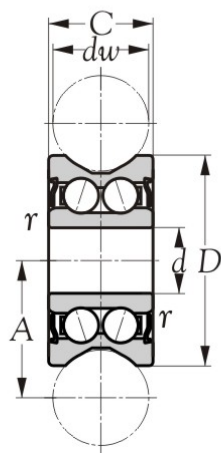

Items (9)	Data  Model nos.	Dimension			Packing method	Quantity  Min. order qty.  Pcs	Delivery  Days	-	2014-09-01	-	Production code(s)			
		Bearing sizes										Unit price structure  USD	Unit price structure  USD	Compare percentages (%)
		d	D	C										
		mm												
1	<b>RV 20/7-10</b>	7	22	11	N1	250	120	-	<b>4.11</b>	-	WL			
2	* <b>RV 20/8-10</b>	8	30	14	N1	250	120	-	<b>4.19</b>	-	WL			
3	* <b>RV 202/15.38-10</b>	15	38	17	N1	200	120	-	<b>5.46</b>	-	WL			
4	* <b>RV 20/15.40-10</b>	15	40	18	N1	190	120	-	<b>5.99</b>	-	WL			
5	* <b>RV 201/12-20</b>	12	41	20	N1	180	120	-	<b>5.61</b>	-	WL			
6	* <b>RV 202/15.41-20</b>	15	41	20	N1	170	120	-	<b>6.60</b>	-	WL			
7	* <b>RV 203/17-20</b>	17	58	25	N1	170	120	-	<b>6.60</b>	-	WL			
8	<b>RV 204/20.57-30</b>	20	57	22	N1	130	120	-	<b>8.70</b>	-	WL			
9	<b>RV 204/20.58-30</b>	20	58	25	N1	120	120	-	<b>9.90</b>	-	WL			

Remark	Technical supplement									
	Cage(s)	Precision	Grease							
	<table border="1"> <tr> <td>Steel -</td> <td>×</td> </tr> <tr> <td>Polymid -</td> <td>✓</td> </tr> <tr> <td>Brass -</td> <td>×</td> </tr> </table>	Steel -	×	Polymid -	✓	Brass -	×	<table border="1"> <tr> <td><b>Class 0</b> (JIS)</td> </tr> </table>	<b>Class 0</b> (JIS)	<table border="1"> <tr> <td><b>Alvania S2</b> -25°C ~ +120°C</td> </tr> </table>
Steel -	×									
Polymid -	✓									
Brass -	×									
<b>Class 0</b> (JIS)										
<b>Alvania S2</b> -25°C ~ +120°C										

Qualified Sub-contractor(s)	Since
<b>WL</b>	2005
-	-
-	-

TRACK ROLLER BEARINGS DOUBLE ROW  
SERIES **RM..2Z; RM..2RS**

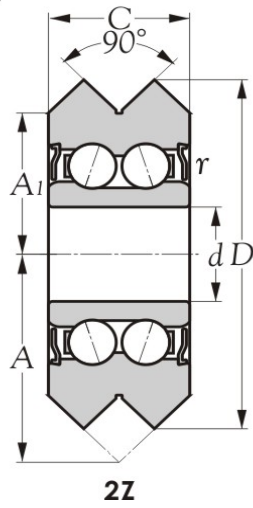

**2Z**

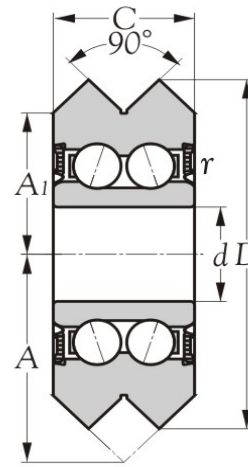

**2RS**

Items (8)	Data  Model nos.	Dimension			Packing method	Quantity  Min. order qty.	Delivery  Days	-	2014-09-01	Compare percentages (%)	Production code(s)		
		Bearing sizes										Unit price structure	Unit price structure
		d	D	C									
		mm				Pcs							
1	* RM 1 ZZ (5x1)	4.763	19.56	7.87	N2	250	120	-	4.65	-	WL		
2	* RM 2 ZZ	9.525	30.73	11.1	N1	250	120	-	5.25	-	WL		
3	* RM 3 ZZ	12	45.72	15.88	N1	180	120	-	6.60	-	WL		
4	* RM 4 ZZ	15	59.94	19.05	N1	130	120	-	11.09	-	WL		
5	RM 1 2RS (5x1)	4.763	19.56	7.87	N2	250	120	-	4.65	-	WL		
6	RM 2 2RS	9.525	30.73	11.1	N1	250	120	-	5.25	-	WL		
7	RM 3 2RS	12	45.72	15.88	N1	180	120	-	6.60	-	WL		
8	RM 4 2RS	15	59.94	19.05	N1	130	120	-	11.09	-	WL		

Remark	Technical supplement		
	Cage(s)	Precision	Grease
	Steel - <input checked="" type="checkbox"/>	Class 0 (JIS)	Alvania S2 -25°C~+120°C
	Polymid - <input checked="" type="checkbox"/>		
	Brass - <input checked="" type="checkbox"/>		

Qualified Sub-contractor(s)	Since
WL	2005
-	-
-	-

TRACK ROLLER BEARINGS DOUBLE ROW  
SERIES **RV..C; RV..E**

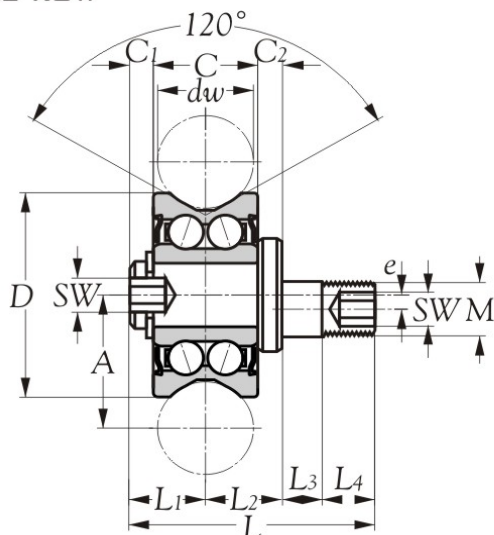

Items (10)	Data	Dimension			Packing method	Quantity Min. order qty.	Delivery	-	2014-09-01	Compare percentages (%)	Production code(s)		
	Model nos.	Bearing sizes										Unit price structure	Unit price structure
		d	D	C									
		mm			Pcs	Days	USD	USD					
1	RV 22 C	-	-	-	-	-	-	-	-	-	-		
2	RV 30 C	-	-	-	-	-	-	-	-	-	-		
3	RV 38 C	-	-	-	-	-	-	-	-	-	-		
4	RV 41 C	-	-	-	-	-	-	-	-	-	-		
5	RV 58 C	-	-	-	-	-	-	-	-	-	-		
6	RV 22 E	-	-	-	-	-	-	-	-	-	-		
7	RV 30 E	-	-	-	-	-	-	-	-	-	-		
8	RV 38 E	-	-	-	-	-	-	-	-	-	-		
9	RV 41 E	-	-	-	-	-	-	-	-	-	-		
10	RV 58 E	-	-	-	-	-	-	-	-	-	-		

<b>Remark</b>	Technical supplement	Precision	Grease
	Cage(s)		
	Steel - X	Class 0 (JIS)	Alvania S2 -25°C~+120°C
	Polymid - X		
Brass - X			

Qualified Sub-contractor(s)	Since
-	-
-	-
-	-

TRACKROLLERBEARINGS DOUBLEROW  
SERIES **RPC; RPE**

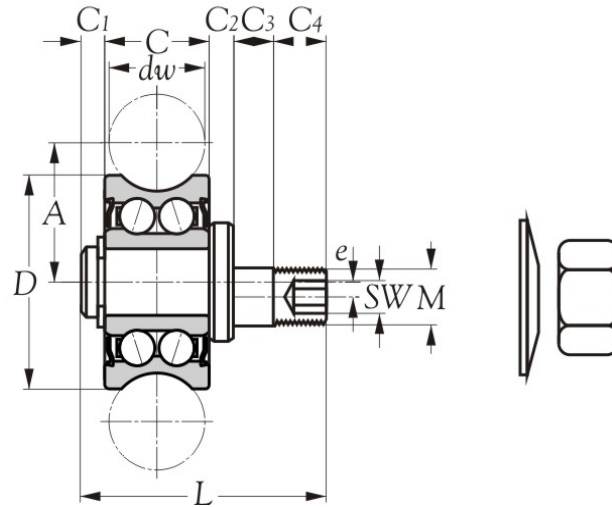

Items (6)	Data  Model nos.	Dimension			Packing method	Quantity  Min. order qty.	Delivery	-	2014-09-01	Compare percentages (%)	Production code(s)		
		Bearing sizes										Unit price structure	Unit price structure
		d	D	C									
		mm				Pcs	Days	USD	USD				
1	RPC 17	-	-	-	-	-	-	-	-	-	-		
2	RPC 24	-	-	-	-	-	-	-	-	-	-		
3	RPC 35	-	-	-	-	-	-	-	-	-	-		
4	RPE 17	-	-	-	-	-	-	-	-	-	-		
5	RPE 24	-	-	-	-	-	-	-	-	-	-		
6	RPE 35	-	-	-	-	-	-	-	-	-	-		

<b>Remark</b>	Technical supplement	Precision	Grease
	Cage(s)		
	Steel - X	Class 0 (JIS)	Alvania S2 -25°C ~ +120°C
	Polymid - X		
Brass - X			

Qualified Sub-contractor(s)	Since
-	-
-	-
-	-

TRACK ROLLER BEARINGS DOUBLE ROW  
SERIES **RA..A**

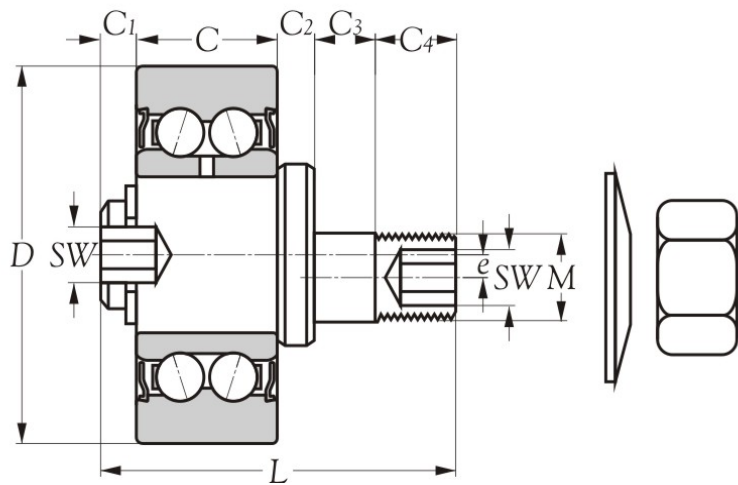

Items (2)	Data	Dimension			Packing method	Quantity Min. order qty.	Delivery	-	2014-09-01	Compare percentages (%)	Production code(s)
	Model nos.	Bearing sizes						Unit price structure	Unit price structure		
		d	D	C							
		mm			Pcs	Days	USD	USD			
1	RA 35 A	-	-	-	-	-	-	-	-	-	-
2	RA 52 A	-	-	-	-	-	-	-	-	-	-

<b>Remark</b>	Technical supplement		
	Cage(s)	Precision	Grease
	Steel - <input checked="" type="checkbox"/>	Nil	Nil
	Polymid - <input checked="" type="checkbox"/>		
Brass - <input checked="" type="checkbox"/>			

Qualified Sub-contractor(s)	Since
-	-
-	-
-	-



# ROD ENDS



**SPHERICAL BEARING ROD ENDS (LUBRICANT TYPE)**  
**SERIES BNM..., BNML..**

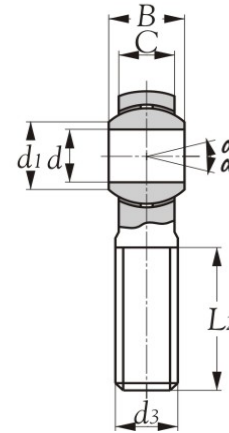
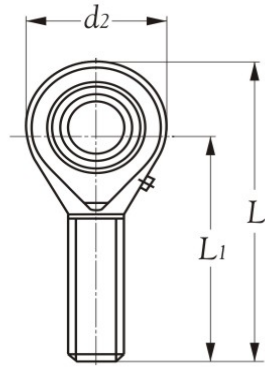

Items (12)	Data  Model nos.	Dimension			Packing method	Quantity  Min. order qty.	Delivery	-		2014-09-01	Compare percentages (%)	Production code(s)
		Bearing sizes						Unit price structure	Unit price structure			
		d2	L	B								
mm			Pcs	Days	USD	USD						
1	* BNM 5	16	41	8	N1	700	90	-	1.60	-	YX	
2	* BNM 6	18	45	9	N1	700	90	-	1.60	-	YX	
3	BNM 8	22	53	12	N1	600	90	-	1.84	-	YX	
4	* BNM 10	26	61	14	N1	450	90	-	2.28	-	YX	
5	* BNM 12	30	69	16	N1	400	90	-	2.68	-	YX	
6	* BNM 14	34	77	19	N1	300	90	-	3.75	-	YX	
7	* BNM 16	38	85	21	N1	250	90	-	4.29	-	YX	
8	BNM 18	42	93	23	N1	150	90	-	6.54	-	YX	
9	* BNM 20	46	101	25	N1	130	90	-	7.70	-	YX	
10	BNM 22	50	109	28	N1	100	90	-	9.94	-	YX	
11	BNM 25	60	124	31	N1	80	90	-	12.26	-	YX	
12	BNM 30	70	145	37	N1	50	90	-	20.05	-	YX	

Remark : 1. Suffix "L" means with left hand thread, and keeps the same price with item without "L".

Remark	Technical supplement		
	Cage(s)	Precision	Grease
	Steel - X	Class 0 (JIS)	Nil
	Polymid - X		
	Brass - X		

Qualified Sub-contractor(s)	Since
YX	2003
-	-
-	-

**SPHERICAL BEARING ROD ENDS (LUBRICANT TYPE)**  
**SERIES BNF.., BNFL..**

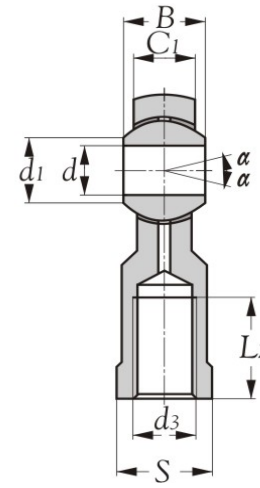
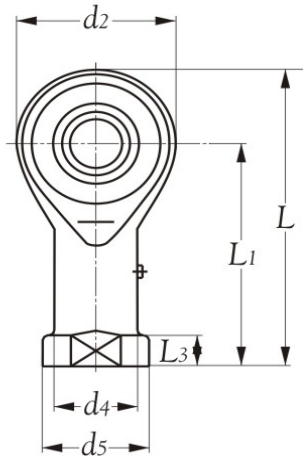

Items (16)	Data  Model nos.	Dimension			Packing method	Quantity  Min. order qty.	Delivery  Days	Unit price structure  USD	2014-09-01 Unit price structure  USD	Compare percentages (%)	Production code(s)
		Bearing sizes									
		d2	L	S							
		mm				Pcs					
1	* BNF 5	16	35	9	N1	700	90	-	1.60	-	YX
2	* BNF 6	18	39	11	N1	700	90	-	1.60	-	YX
3	BNF 8	22	47	14	N1	600	90	-	1.84	-	YX
4	* BNF 10	26	56	17	N1	450	90	-	2.28	-	YX
5	* BNF 10.1	26	56	17	N1	450	90	-	2.28	-	YX
6	* BNF 12	30	65	19	N1	400	90	-	2.68	-	YX
7	* BNF 12.1	30	65	19	N1	400	90	-	2.68	-	YX
8	BNF 14	34	74	22	N1	300	90	-	3.75	-	YX
9	* BNF 16	38	83	22	N1	250	90	-	4.29	-	YX
10	* BNF 16.1	38	83	22	N1	250	90	-	4.29	-	YX
11	BNF 18	42	92	27	N1	150	90	-	6.54	-	YX
12	* BNF 20	46	100	30	N1	130	90	-	7.70	-	YX
13	BNF 22	50	109	32	N1	100	90	-	9.94	-	YX
14	BNF 25	60	124	36	N1	80	90	-	12.26	-	YX
15	BNF 30	70	145	41	N1	50	90	-	20.05	-	YX
16	BNF 30.1	70	145	41	N1	50	90	-	20.11	-	YX

Remark : 1. Suffix "L" means with left hand thread, and keeps the same price with item without "L".

Remark	Technical supplement		
	Cage(s)	Precision	Grease
	Steel - X	Class 0 (JIS)	Nil
	Polymid - X		
	Brass - X		

Qualified Sub-contractor(s)	Since
YX	2003
-	-
-	-



SPHERICAL BEARING ROD ENDS (MAINTENANCE-FREE TYPE)

SERIES **DM.., DML..**

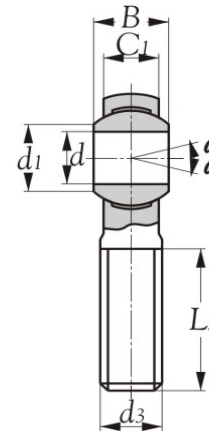
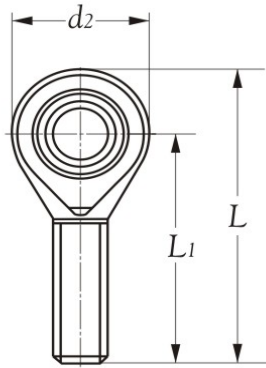

Items (12)	Data  Model nos.	Dimension			Packing method	Quantity  Min. order qty.	Delivery  Days	-	2014-09-01	Compare percentages (%)	Production code(s)		
		Bearing sizes										Unit price structure	Unit price structure
		d2	L	B									
		mm				Pcs		USD	USD				
1	DM 5	16	41	8	N1	700	90	-	1.60	-	YX		
2	DM 6	18	45	9	N1	700	90	-	1.60	-	YX		
3	DM 8	22	53	12	N1	600	90	-	1.84	-	YX		
4	DM 10	26	61	14	N1	450	90	-	2.28	-	YX		
5	DM 12	30	69	16	N1	400	90	-	2.68	-	YX		
6	* DM 14	34	77	19	N1	300	90	-	3.75	-	YX		
7	DM 16	38	85	21	N1	250	90	-	4.29	-	YX		
8	DM 18	42	93	23	N1	150	90	-	6.54	-	YX		
9	DM 20	46	101	25	N1	130	90	-	7.70	-	YX		
10	DM 22	50	109	28	N1	100	90	-	9.94	-	YX		
11	DM 25	60	124	31	N1	80	90	-	12.26	-	YX		
12	DM 30	70	145	37	N1	50	90	-	20.05	-	YX		

Remark : 1. Suffix "L" means with left hand thread, and keeps the same price with item without "L".

<b>Remark</b>	Technical supplement		
	Cage(s)	Precision	Grease
	Steel - X	Class 0 (JIS)	Nil
	Polymid - X		
Brass - X			

Qualified Sub-contractor(s)	Since
YX	2003
-	-
-	-

**SPHERICAL BEARING ROD ENDS (MAINTENANCE-FREE TYPE)**

**SERIES DF., DFL..**

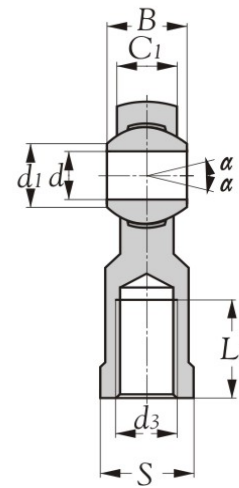
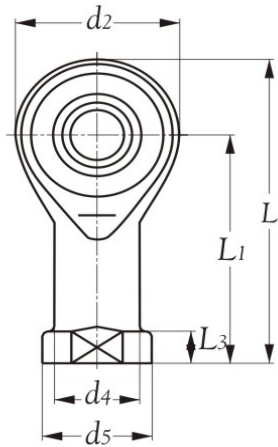

Items (15)	Data  Model nos.	Dimension			Packing method	Quantity  Min. order qty.	Delivery	-		Compare percentages (%)	Production code(s)
		Bearing sizes						Unit price structure	2014-09-01 Unit price structure		
		d2	L	S							
		mm				Pcs	Days	USD	USD		
1	DF 5	16	35	9	N1	700	90	-	1.60	-	YX
2	DF 6	18	39	11	N1	700	90	-	1.60	-	YX
3	DF 8	22	47	14	N1	600	90	-	1.84	-	YX
4	DF 10	26	56	17	N1	450	90	-	2.28	-	YX
5	DF 10.1	26	56	17	N1	140	90	-	2.28	-	YX
6	DF 12	30	65	19	N1	400	90	-	2.68	-	YX
7	DF 12.1	30	65	19	N1	400	90	-	2.68	-	YX
8	DF 14	34	74	22	N1	300	90	-	3.75	-	YX
9	DF 16	38	83	22	N1	250	90	-	4.29	-	YX
10	DF 16.1	38	83	22	N1	250	90	-	4.29	-	YX
11	DF 18	42	92	27	N1	150	90	-	6.54	-	YX
12	DF 20	46	100	30	N1	130	90	-	7.70	-	YX
13	DF 22	50	109	32	N1	100	90	-	9.94	-	YX
14	DF 25	60	124	36	N1	80	90	-	12.26	-	YX
15	DF 30	70	145	41	N1	50	90	-	20.05	-	YX

Remark : 1. Suffix "L" means with left hand thread, and keeps the same price with item without "L".

<b>Remark</b>	Technical supplement		
	Cage(s)	Precision	Grease
	Steel - X	Class 0 (JIS)	Nil
	Polymid - X		
Brass - X			

Qualified Sub-contractor(s)	Since
YX	2003
-	-
-	-

SPHERICAL BEARING ROD ENDS (MAINTENANCE-FREE TYPE)

SERIES **BNM..K, BNML..K**

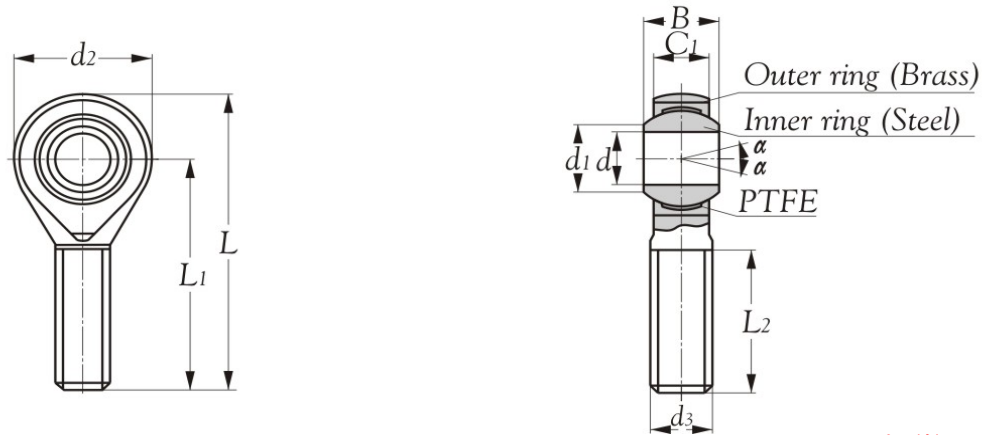

Items (12)	Data  Model nos.	Dimension			Packing method	Quantity  Min. order qty.	Delivery  Days	Unit price structure  USD	2014-09-01  Unit price structure  USD	Compare percentages (%)	Production code(s)
		Bearing sizes									
		d2	L	B							
		mm				Pcs					
1	* BNM 5 K	18	42	8	N1	700	90	-	1.60	-	YX
2	* BNM 6 K	20	46	9	N1	700	90	-	1.60	-	YX
3	* BNM 8 K	24	54	12	N1	600	90	-	1.84	-	YX
4	* BNM 10 K	28	62	14	N1	450	90	-	2.28	-	YX
5	* BNM 12 K	32	70	16	N1	400	90	-	2.68	-	YX
6	* BNM 14 K	36	78	19	N1	300	90	-	3.75	-	YX
7	* BNM 16 K	42	87	21	N1	250	90	-	4.29	-	YX
8	* BNM 18 K	46	95	23	N1	150	90	-	6.54	-	YX
9	* BNM 20 K	50	103	25	N1	130	90	-	7.70	-	YX
10	* BNM 22 K	54	111	28	N1	100	90	-	9.94	-	YX
11	* BNM 25 K	60	124	31	N1	80	90	-	12.26	-	YX
12	* BNM 30 K	70	145	37	N1	50	90	-	20.05	-	YX

Remark : 1. Suffix "L" means with left hand thread, and keeps the same price with item without "L".

Remark	Technical supplement		
	Cage(s)	Precision	Grease
	Steel - <input checked="" type="checkbox"/>	Class 0 (JIS)	Nil
	Polymid - <input checked="" type="checkbox"/>		
	Brass - <input checked="" type="checkbox"/>		

Qualified Sub-contractor(s)	Since
YX	2003
-	-
-	-

SPHERICAL BEARING ROD ENDS (MAINTENANCE-FREE TYPE)

SERIES **BNF..K, BNFL..K**

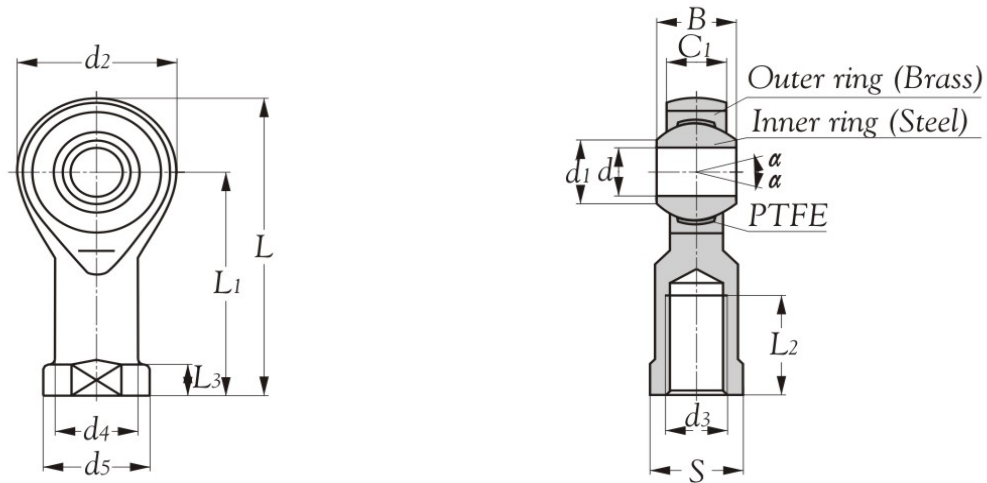

Items (15)	Data  Model nos.	Dimension			Packing method	Quantity  Min. order qty.	Delivery  Days	Unit price structure  USD	2014-09-01  Unit price structure  USD	Compare percentages (%)	Production code(s)
		Bearing sizes									
		d2	L	S							
		mm				Pcs					
1	* BNF 5 K	18	36	9	N1	700	90	-	1.60	-	YX
2	* BNF 6 K	20	40	11	N1	700	90	-	1.60	-	YX
3	* BNF 8 K	24	48	13	N1	600	90	-	1.84	-	YX
4	* BNF 10 K	28	57	17	N1	450	90	-	2.28	-	YX
5	* BNF 10.1 K	28	57	17	N1	450	90	-	2.28	-	YX
6	* BNF 12 K	32	66	19	N1	400	90	-	2.68	-	YX
7	* BNF 12.1 K	32	66	19	N1	400	90	-	2.68	-	YX
8	* BNF 14 K	36	75	22	N1	300	90	-	3.75	-	YX
9	* BNF 16 K	42	85	22	N1	250	90	-	4.29	-	YX
10	* BNF 16.1 K	42	85	22	N1	250	90	-	4.29	-	YX
11	* BNF 18 K	46	94	27	N1	150	90	-	6.54	-	YX
12	* BNF 20 K	50	102	32	N1	130	90	-	7.70	-	YX
13	BNF 22 K	54	111	32	N1	100	90	-	9.94	-	YX
14	* BNF 25 K	60	124	36	N1	80	90	-	12.26	-	YX
15	* BNF 30 K	70	145	41	N1	50	90	-	20.05	-	YX

Remark : 1. Suffix "L" means with left hand thread, and keeps the same price with item without "L".

Remark	Technical supplement		
	Cage(s)	Precision	Grease
	Steel - <input checked="" type="checkbox"/>	Class 0 (JIS)	Nil
	Polymid - <input checked="" type="checkbox"/>		
	Brass - <input checked="" type="checkbox"/>		

Qualified Sub-contractor(s)	Since
YX	2003
-	-
-	-

**STAINLESS STEEL SPHERICAL BEARING ROD ENDS (MAINTENANCE-FREE TYPE)  
SERIES DMSS., DMSSL..**

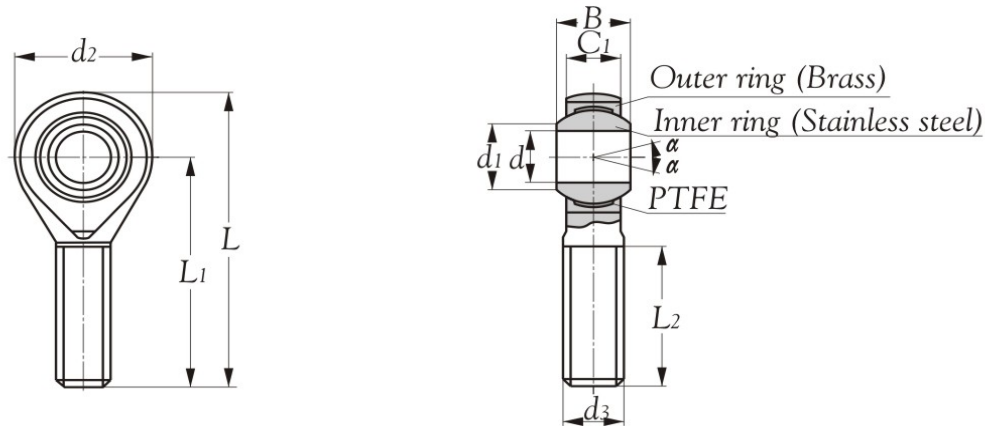

Items (12)	Data  Model nos.	Dimension			Packing method	Quantity  Min. order qty.	Delivery  Days	-		Compare percentages (%)	Production code(s)
		Bearing sizes						Unit price structure	Unit price structure		
		d2	L	B							
mm			Pcs	USD	USD						
1	DMSS 5	16	41	8	N1	160	90	-	6.13	-	YX
2	DMSS 6	18	45	9	N1	160	90	-	6.13	-	YX
3	DMSS 8	22	53	12	N1	140	90	-	7.13	-	YX
4	DMSS 10	26	61	14	N1	120	90	-	8.50	-	YX
5	DMSS 12	30	69	16	N1	110	90	-	9.69	-	YX
6	DMSS 14	34	77	19	N1	80	90	-	13.83	-	YX
7	DMSS 16	38	85	21	N1	60	90	-	16.66	-	YX
8	DMSS 18	42	93	23	N1	40	90	-	24.94	-	YX
9	DMSS 20	46	101	25	N1	35	90	-	30.10	-	YX
10	DMSS 22	50	109	28	N1	30	90	-	37.63	-	YX
11	DMSS 25	60	124	31	N1	25	90	-	47.50	-	YX
12	DMSS 30	70	145	37	N1	15	90	-	78.38	-	YX

Remark : 1. Suffix "L" means with left hand thread, and keeps the same price with item without "L".

Remark	Technical supplement		
	Cage(s)	Precision	Grease
	Steel - X	Class 0 (JIS)	Nil
	Polymid - X		
	Brass - X		

Qualified Sub-contractor(s)	Since
YX	2003
-	-
-	-

**STAINLESS STEEL SPHERICAL BEARING ROD ENDS (MAINTENANCE-FREE TYPE)  
SERIES DFSS., DFSSL..**

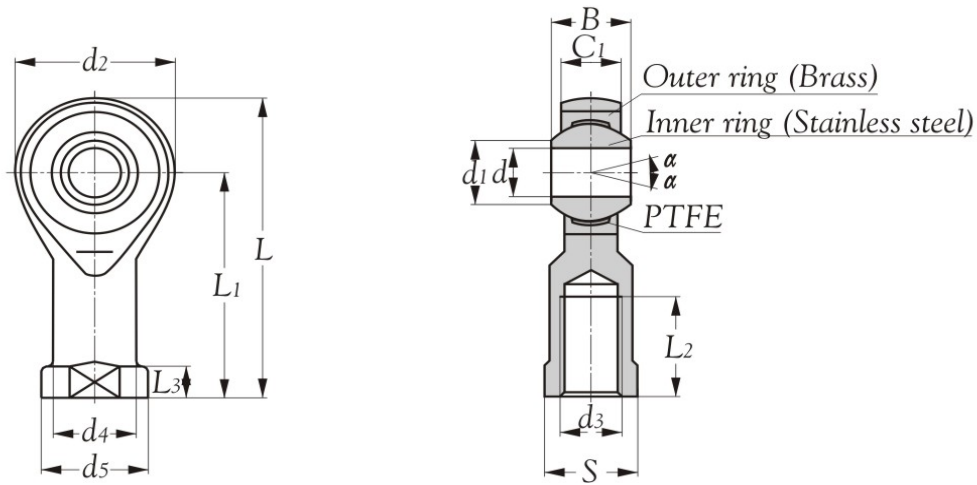

Items (15)	Data  Model nos.	Dimension			Packing method	Quantity  Min. order qty.	Delivery	-		Compare percentages (%)	Production code(s)
		Bearing sizes						Unit price structure	2014-09-01 Unit price structure		
		d2	L	S							
		mm				Pcs	Days	USD	USD		
1	DFSS 5	16	35	9	N1	160	90	-	6.13	-	YX
2	DFSS 6	18	39	11	N1	160	90	-	6.13	-	YX
3	DFSS 8	22	47	14	N1	140	90	-	7.13	-	YX
4	DFSS 10	26	56	17	N1	120	90	-	8.50	-	YX
5	DFSS 10.1	26	56	17	N1	120	90	-	8.50	-	YX
6	DFSS 12	30	65	19	N1	110	90	-	9.69	-	YX
7	DFSS 12.1	30	65	19	N1	110	90	-	9.69	-	YX
8	DFSS 14	34	74	22	N1	80	90	-	13.83	-	YX
9	DFSS 16	38	83	22	N1	60	90	-	16.66	-	YX
10	DFSS 16.1	38	83	22	N1	60	90	-	16.66	-	YX
11	DFSS 18	42	92	27	N1	40	90	-	24.94	-	YX
12	DFSS 20	46	100	30	N1	35	90	-	30.10	-	YX
13	DFSS 22	50	109	32	N1	30	90	-	37.63	-	YX
14	DFSS 25	60	124	36	N1	25	90	-	47.50	-	YX
15	DFSS 30	70	145	41	N1	15	90	-	78.38	-	YX

Remark : 1. Suffix "L" means with left hand thread, and keeps the same price with item without "L".

Remark	Technical supplement		
	Cage(s)	Precision	Grease
	Steel - X	Class 0 (JIS)	Nil
	Polymid - X		
	Brass - X		

Qualified Sub-contractor(s)	Since
YX	2003
-	-
-	-

WINDING SHAPE BALL JOINT RODEND  
SERIES **RBL...**

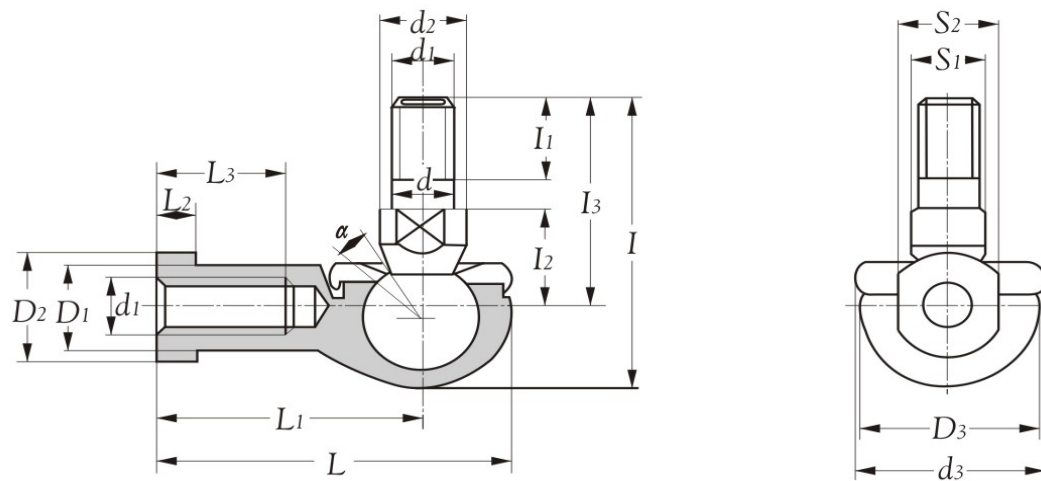

Items (14)	Data  Model nos.	Dimension			Packing method	Quantity  Min. order qty.	Delivery  Days	-		Compare percentages (%)	Production code(s)
		Bearing sizes						Unit price structure	Unit price structure		
		d3	L	I							
mm			Pcs	USD	USD						
1	<b>RBL 5</b>	19	35	29	N1	300	90	-	<b>3.61</b>	-	YX
2	<b>RBL 6</b>	20	40	35.5	N1	300	90	-	<b>3.83</b>	-	YX
3	<b>RBL 8</b>	24	48	42.5	N1	250	90	-	<b>4.26</b>	-	YX
4	<b>RBL 10</b>	30	57	50.5	N1	250	90	-	<b>4.63</b>	-	YX
5	<b>RBL 10 B</b>	30	57	56.5	N1	250	90	-	<b>4.63</b>	-	YX
6	<b>RBL 12</b>	32	66	57.5	N1	190	90	-	<b>5.15</b>	-	YX
7	<b>RBL 12 B</b>	32	66	64.5	N1	190	90	-	<b>5.15</b>	-	YX
8	<b>RBL 14</b>	38	75	73.5	N1	160	90	-	<b>6.40</b>	-	YX
9	<b>RBL 14 B</b>	38	75	79.5	N1	160	90	-	<b>6.40</b>	-	YX
10	<b>RBL 16</b>	44	84	79.5	N1	120	90	-	<b>8.55</b>	-	YX
11	<b>RBL 16 B</b>	44	84	85.5	N1	120	90	-	<b>8.55</b>	-	YX
12	<b>RBL 18</b>	45	93	90	N1	110	90	-	<b>9.50</b>	-	YX
13	<b>RBL 20</b>	50	99	90	N1	100	90	-	<b>10.54</b>	-	YX
14	<b>RBL 22</b>	52	100	95	N1	90	90	-	<b>11.88</b>	-	YX

Remark	Technical supplement		
	Cage(s)	Precision	Grease
	Steel - <input checked="" type="checkbox"/>	Class 0 (JIS)	Nil
	Polymid - <input checked="" type="checkbox"/>		
	Brass - <input checked="" type="checkbox"/>		

Qualified Sub-contractor(s)	Since
YX	2003
-	-
-	-

**STRAIGHT BALL JOINT ROD ENDS**  
**SERIES RBI...**

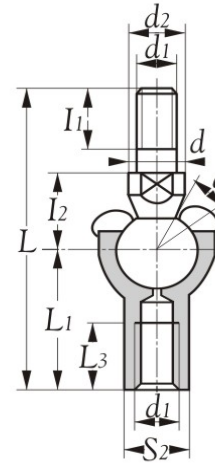
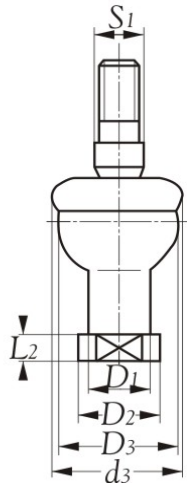

Items (14)	Data  Model nos.	Dimension			Packing method	Quantity  Min. order qty.	Delivery  Days	-		Compare percentages (%)	Production code(s)
		Bearing sizes						Unit price structure	2014-09-01 Unit price structure		
		d3	L	-							
								USD	USD		
			mm		Pcs			USD	USD		
1	RBI 5	20	46	-	N1	250	90	-	3.93	-	YX
2	RBI 6	20	55.2	-	N1	250	90	-	4.16	-	YX
3	RBI 8	24	65	-	N1	250	90	-	4.59	-	YX
4	RBI 10	30	74.5	-	N1	200	90	-	5.04	-	YX
5	RBI 10 B	30	80.5	-	N1	200	90	-	5.04	-	YX
6	RBI 12	32	84	-	N1	180	90	-	5.50	-	YX
7	RBI 12 B	32	91	-	N1	180	90	-	5.50	-	YX
8	RBI 14	-	-	-	-	-	-	-	-	-	-
9	RBI 14 B	-	-	-	-	-	-	-	-	-	-
10	RBI 16	-	-	-	-	-	-	-	-	-	-
11	RBI 16 B	-	-	-	-	-	-	-	-	-	-
12	RBI 18	-	-	-	-	-	-	-	-	-	-
13	RBI 20	-	-	-	-	-	-	-	-	-	-
14	RBI 22	-	-	-	-	-	-	-	-	-	-

<b>Remark</b>	Technical supplement		
	Cage(s)	Precision	Grease
	Steel - X	Class 0 (JIS)	Nil
	Polymid - X		
Brass - X			

Qualified Sub-contractor(s)	Since
YX	2003
-	-
-	-