

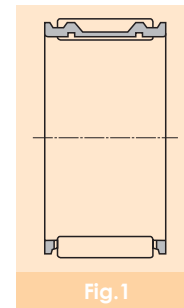

NEEDLE ROLLER AND CAGE ASSEMBLIES

1. Types and designs

NIKO Needle Roller and Cage Assemblies are supplied in single row (Fig. 1). The single row cages are available in two configurations: machined ring (series K), and molded polyamide reinforced with glass or carbon fiber (series K- -T2). The T2 cage features a maximum allowable operating temperature of 120°C and maximum allowable continuous operating temperature of 100°C .



2. Bearing numbers

As summarized in Fig. 2, the bearing numbers of **NIKO** Needle Roller and Cage Assemblies comprise a series number, a dimension code (inscribed enveloping circle diameter × roller set outside diameter × cage width), and a suffix.

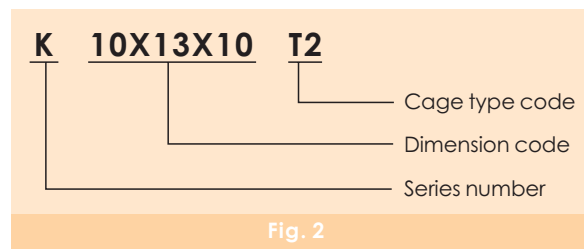

3. Radial clearance

When the shaft and housing are used as the raceway, the radial clearance of the ball and cage assembly is governed by the shaft diameter and housing bore dimension. Usually, if the tolerance range of the needle rollers is one of the standard groups, the shaft diameter and housing bore diameter in Table 1 are used.

Table 1 Recommended fits

Shaft dia. mm		~80	80~140	140~
Radial clearance	Smaller than normal clearance	j5/G6	h5/G6	h5/G6
	Normal clearance	h5/G6	g5/G6	f5/H6
	Greater than normal clearance	g6/G6	f6/G6	f6/G6

4. Shaft and housing requirements

When used as a raceway, a shaft and housing must satisfy the requirements indicated in Table 2.

Table 2 Shaft and housing requirements

Characteristics	Shaft	Housing
Circularity (max.)	IT3	IT4
Cylindricity (max.)	IT3	IT4
Surface roughness (max.)	0.4a	0.4a
Surface roughness (max.)	HRC58~64	

5. Mounting dimensions for bearings

Table 3 gives the recommended tolerance for the cage guide width *b* dimension relative to the nominal dimension " *Bc* ".

Table 3 Tolerance for guide width

Series classification	Tolerance for <i>b</i>
Metric	$Bc^{+0.2}_0$

CAGE AND ROLLER TYPE NEEDLE ROLLER BEARINGS
SERIES K

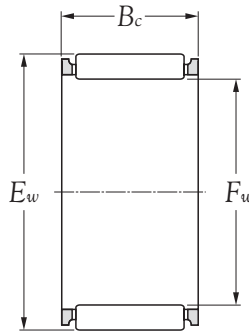

Boundary dimensions			Basic load ratings				Limiting speeds		Bearing numbers	Mass kg (Approx.)
mm			dynamic N	static	dynamic kgf	static	rpm			
F_w	E_w	B_c	C_r	C_{or}	C_r	C_{or}	grease	oil		
3	6	7 ^{-0.2} _{-0.55}	1,460	970	149	99	33,000	50,000	K 3X6X7	0.0004
4	7	7 ^{-0.2} _{-0.55}	1,770	1,270	180	129	30,000	45,000	K 4X7X7	0.0005
5	8	8 ^{-0.2} _{-0.55}	2,640	2,190	269	224	27,000	40,000	K 5X8X8	0.0007
5	8	10 ^{-0.2} _{-0.55}	2,720	2,250	277	230	27,000	40,000	K 5X8X10	0.0009
6	9	8 ^{-0.2} _{-0.55}	2,660	2,280	272	233	25,000	37,000	K 6X9X8	0.0009
6	9	10 ^{-0.2} _{-0.55}	3,400	3,150	345	320	25,000	37,000	K 6X9X10	0.0011
6	10	13 ^{-0.2} _{-0.55}	4,400	3,700	450	380	25,000	37,000	K 6X10X13	0.0019
7	10	8 ^{-0.2} _{-0.55}	2,670	2,350	272	239	23,000	34,000	K 7X10X8	0.0009
7	10	10 ^{-0.2} _{-0.55}	3,400	3,200	345	330	23,000	34,000	K 7X10X10	0.0011
8	11	8 ^{-0.2} _{-0.55}	3,150	3,000	320	305	21,000	32,000	K 8X11X8	0.0011
8	11	10 ^{-0.2} _{-0.55}	4,000	4,100	410	420	21,000	32,000	K 8X11X10	0.0013
8	11	13 ^{-0.2} _{-0.55}	4,850	5,200	495	535	21,000	32,000	K 8X11X13	0.0026
8	12	10 ^{-0.2} _{-0.55}	4,650	4,150	475	425	21,000	32,000	K 8X12X10	0.0020
8	12	12 ^{-0.2} _{-0.55}	5,600	5,300	570	540	21,000	32,000	K 8X12X12	0.0034
8	12	13 ^{-0.2} _{-0.55}	5,600	5,300	570	540	21,000	32,000	K 8X12X13	0.0036
9	12	10 ^{-0.2} _{-0.55}	4,550	5,000	465	510	20,000	30,000	K 9X12X10	0.0015
9	12	13 ^{-0.2} _{-0.55}	5,500	6,400	560	650	20,000	30,000	K 9X12X13	0.0021
10	13	10 ^{-0.2} _{-0.55}	4,550	5,100	460	520	19,000	28,000	K 10X13X10	0.0016
10	13	13 ^{-0.2} _{-0.55}	5,450	6,450	555	660	19,000	28,000	K 10X13X13	0.0031
10	14	8 ^{-0.2} _{-0.55}	4,300	3,950	435	405	19,000	28,000	K 10X14X8	0.0027
10	14	10 ^{-0.2} _{-0.55}	5,500	5,450	560	555	19,000	28,000	K 10X14X10	0.0034
10	14	13 ^{-0.2} _{-0.55}	6,600	6,900	675	705	19,000	28,000	K 10X14X13	0.0044
10	16	12 ^{-0.2} _{-0.55}	7,100	5,950	720	610	19,000	28,000	K 10X16X12	0.0066
11	14	10 ^{-0.2} _{-0.55}	5,050	6,000	515	615	18,000	27,000	K 11X14X10	0.0028
12	15	9 ^{-0.2} _{-0.55}	4,450	5,250	455	535	17,000	26,000	K 12X15X9	0.0027
12	15	13 ^{-0.2} _{-0.55}	6,000	7,700	615	785	17,000	26,000	K 12X15X13	0.0038
12	16	8 ^{-0.2} _{-0.55}	4,850	4,900	495	500	17,000	26,000	K 12X16X8	0.0034
12	16	13 ^{-0.2} _{-0.55}	7,500	8,500	765	870	17,000	26,000	K 12X16X13	0.0055

CAGE AND ROLLER TYPE NEEDLE ROLLER BEARINGS
SERIES K

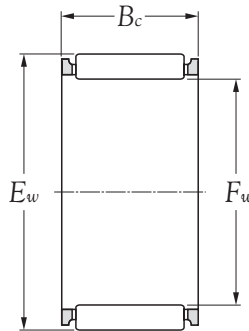

Boundary dimensions			Basic load ratings				Limiting speeds		Bearing numbers	Mass kg (approx.)
mm			dynamic	static	dynamic	static	rpm			
F_w	E_w	B_c	N		kgf		grease	oil		
12	17	13 ^{-0.2/-0.55}	9,000	9,400	920	960	17,000	26,000	K 12X17X13	0.0075
12	18	12 ^{-0.2/-0.55}	8,650	8,000	880	815	17,000	26,000	K 12X18X12	0.0084
14	17	10 ^{-0.2/-0.55}	5,400	7,050	550	720	16,000	24,000	K 14X17X10	0.0033
14	18	10 ^{-0.2/-0.55}	6,900	8,000	705	815	16,000	24,000	K 14X18X10	0.0046
14	18	11 ^{-0.2/-0.55}	7,600	9,050	775	925	16,000	24,000	K 14X18X11	0.0053
14	18	13 ^{-0.2/-0.55}	8,300	10,100	845	1,030	16,000	24,000	K 14X18X13	0.0063
14	18	17 ^{-0.2/-0.55}	10,900	14,400	1,120	1,470	16,000	24,000	K 14X18X17	0.0081
14	19	13 ^{-0.2/-0.55}	8,950	9,650	915	985	16,000	24,000	K 14X19X13	0.0080
14	20	12 ^{-0.2/-0.55}	9,350	9,150	955	930	16,000	24,000	K 14X20X12	0.0095
14	20	17 ^{-0.2/-0.55}	13,500	14,600	1,370	1,490	16,000	24,000	K 14X20X17	0.0140
15	18	14 ^{-0.2/-0.55}	7,850	11,600	800	1,190	15,000	23,000	K 15X18X14	0.0060
15	19	17 ^{-0.2/-0.55}	10,900	14,600	1,110	1,490	15,000	23,000	K 15X19X17	0.0090
15	20	13 ^{-0.2/-0.55}	10,100	11,500	1,030	1,170	15,000	23,000	K 15X20X13	0.0088
15	21	15 ^{-0.2/-0.55}	11,900	12,500	1,210	1,280	15,000	23,000	K 15X21X15	0.0130
15	21	21 ^{-0.2/-0.55}	16,500	19,100	1,680	1,950	15,000	23,000	K 15X21X21	0.0170
16	20	10 ^{-0.2/-0.55}	7,500	9,250	765	945	15,000	23,000	K 16X20X10	0.0057
16	20	11 ^{-0.2/-0.55}	8,300	10,500	845	1,070	15,000	23,000	K 16X20X11	0.0061
16	20	13 ^{-0.2/-0.55}	9,050	11,800	925	1,200	15,000	23,000	K 16K 20X13	0.0071
16	22	12 ^{-0.2/-0.55}	11,700	12,500	1,190	1,280	15,000	23,000	K 16X22X12	0.0100
16	22	17 ^{-0.2/-0.55}	14,400	16,400	1,470	1,670	15,000	23,000	K 16X22X17	0.0150
16	22	20 ^{-0.2/-0.55}	16,000	18,800	1,640	1,920	15,000	23,000	K 16X22X20	0.0170
17	21	15 ^{-0.2/-0.55}	10,400	14,400	1,060	1,460	15,000	22,000	K 17X21X15	0.0089
17	21	17 ^{-0.2/-0.55}	11,800	16,900	1,210	1,720	15,000	22,000	K 17X21X17	0.0095
17	22	20 ^{-0.2/-0.55}	14,700	19,200	1,500	1,960	15,000	22,000	K 17X22X20	0.0150
17	23	17 ^{-0.2/-0.55}	14,400	16,500	1,460	1,690	15,000	22,000	K 17X23X17	0.0160
18	22	10 ^{-0.2/-0.55}	7,400	9,400	755	955	14,000	21,000	K 18X22X10	0.0061
18	22	13 ^{-0.2/-0.55}	8,900	11,900	910	1,210	14,000	21,000	K 18X22X13	0.0077
18	22	17 ^{-0.2/-0.55}	11,700	17,000	1,200	1,730	14,000	21,000	K 18X22X17	0.0110

CAGE AND ROLLER TYPE NEEDLE ROLLER BEARINGS
SERIES K

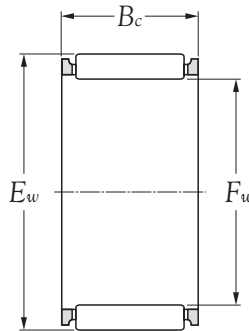

Boundary dimensions			Basic load ratings				Limiting speeds		Bearing numbers	Mass kg (approx.)
mm			dynamic	static	dynamic	static	rpm			
F_w	E_w	B_c	N		kgf		grease	oil		
18	24	12 ^{-0.2/-0.55}	12,300	13,800	1,250	1,410	14,000	21,000	K 18X24X12	0.0120
18	24	13 ^{-0.2/-0.55}	11,600	12,800	1,180	1,300	14,000	21,000	K 18X24X13	0.0130
18	24	20 ^{-0.2/-0.55}	17,000	20,900	1,730	2,130	14,000	21,000	K 18X24X20	0.0190
18	25	17 ^{-0.2/-0.55}	18,000	20,400	1,830	2,080	14,000	21,000	K 18X25X17	0.0190
18	25	22 ^{-0.2/-0.55}	22,100	26,600	2,250	2,710	14,000	21,000	K 18X25X22	0.0240
19	23	13 ^{-0.2/-0.55}	9,650	13,500	985	1,370	14,000	21,000	K 19X23X13	0.0082
19	23	17 ^{-0.2/-0.55}	12,700	19,200	1,300	1,960	14,000	21,000	K 19X23X17	0.0110
20	24	11 ^{-0.2/-0.55}	9,500	13,400	970	1,370	13,000	20,000	K 20X24X11	0.0072
20	26	12 ^{-0.2/-0.55}	12,900	15,100	1,320	1,540	13,000	20,000	K 20X26X12	0.0130
20	28	25 ^{-0.2/-0.55}	27,100	32,500	2,760	3,300	13,000	20,000	K 20X28X25	0.0370
21	25	13 ^{-0.2/-0.55}	10,300	15,100	1,050	1,540	13,000	19,000	K 21X25X13	0.0090
21	25	17 ^{-0.2/-0.55}	13,600	21,500	1,380	2,200	13,000	19,000	K 21X25X17	0.0120
22	26	13 ^{-0.2/-0.55}	10,200	15,200	1,040	1,550	12,000	18,000	K 22X26X13	0.0094
22	27	20 ^{-0.2/-0.55}	17,500	25,900	1,780	2,640	12,000	18,000	K 22X27X20	0.0200
22	28	17 ^{-0.2/-0.55}	17,700	23,300	1,810	2,380	12,000	18,000	K 22X28X17	0.0200
22	30	15 ^{-0.2/-0.55}	19,300	21,700	1,970	2,210	12,000	18,000	K 22X30X15	0.0220
23	28	24 ^{-0.2/-0.55}	19,800	31,000	2,020	3,150	11,000	17,000	K 23X28X24	0.0230
24	28	13 ^{-0.2/-0.55}	10,800	16,800	1,100	1,710	11,000	17,000	K 24X28X13	0.0100
24	28	17 ^{-0.2/-0.55}	14,300	23,900	1,460	2,440	11,000	17,000	K 24X28X17	0.0130
24	29	13 ^{-0.2/-0.55}	12,300	16,900	1,250	1,720	11,000	17,000	K 24X29X13	0.0120
24	30	17 ^{-0.2/-0.55}	18,400	25,200	1,880	2,570	11,000	17,000	K 24X30X17	0.0220
25	29	10 ^{-0.2/-0.55}	8,950	13,300	910	1,350	11,000	16,000	K 25X29X10	0.0083
25	29	13 ^{-0.2/-0.55}	10,800	16,900	1,100	1,720	11,000	16,000	K 25X29X13	0.0100
25	30	13 ^{-0.2/-0.55}	13,200	18,800	1,350	1,920	11,000	16,000	K 25X30X13	0.0130
25	31	13 ^{-0.2/-0.55}	15,200	19,900	1,550	2,030	11,000	16,000	K 25X31X13	0.0160
25	31	14 ^{-0.2/-0.55}	16,500	22,100	1,680	2,250	11,000	16,000	K 25X31X14	0.0180
25	31	17 ^{-0.2/-0.55}	18,300	25,300	1,870	2,580	11,000	16,000	K 25X31X17	0.0220
25	31	21 ^{-0.2/-0.55}	22,500	33,000	2,290	3,350	11,000	16,000	K 25X31X21	0.0260

CAGE AND ROLLER TYPE NEEDLE ROLLER BEARINGS
SERIES K

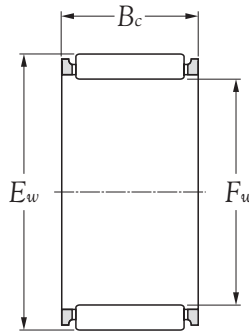

Boundary dimensions			Basic load ratings				Limiting speeds		Bearing numbers	Mass kg (approx.)
mm			dynamic	static	dynamic	static	rpm			
F_w	E_w	B_c	N		kgf		grease	oil		
26	30	13 ^{-0.2/-0.55}	11,800	19,200	1,200	1,960	10,000	15,000	K 26X30X13	0.011
26	30	17 ^{-0.2/-0.55}	15,500	27,400	1,580	2,790	10,000	15,000	K 26X30X17	0.015
26	34	22 ^{-0.2/-0.55}	24,200	30,000	2,470	3,050	10,000	15,000	K 26X34X22	0.041
28	32	17 ^{-0.2/-0.55}	15,300	27,500	1,560	2,810	9,500	14,000	K 28X32X17	0.017
28	32	21 ^{-0.2/-0.55}	18,700	35,500	1,910	3,650	9,500	14,000	K 28X32X21	0.020
28	33	13 ^{-0.2/-0.55}	13,900	20,900	1,420	2,130	9,500	14,000	K 28X33X13	0.015
28	33	27 ^{-0.2/-0.55}	28,300	52,000	2,890	5,300	9,500	14,000	K 28X33X27	0.032
28	34	14 ^{-0.2/-0.55}	17,500	24,800	1,790	2,530	9,500	14,000	K 28X34X14	0.020
28	34	17 ^{-0.2/-0.55}	18,100	25,800	1,850	2,630	9,500	14,000	K 28X34X17	0.024
28	35	16 ^{-0.2/-0.55}	21,200	28,400	2,160	2,900	9,500	14,000	K 28X35X16	0.029
28	35	18 ^{-0.2/-0.55}	21,500	28,900	2,190	2,950	9,500	14,000	K 28X35X18	0.031
29	34	27 ^{-0.2/-0.55}	28,100	52,000	2,870	5,300	9,500	14,000	K 29X34X27	0.033
30	37	16 ^{-0.2/-0.55}	21,900	30,500	2,230	3,100	8,500	13,000	K 30X37X16	0.029
30	37	18 ^{-0.2/-0.55}	23,300	33,000	2,370	3,350	8,500	13,000	K 30X37X18	0.034
30	38	18 ^{-0.2/-0.55}	25,000	33,000	2,550	3,350	8,500	13,000	K 30X38X18	0.036
32	37	13 ^{-0.2/-0.55}	14,500	23,000	1,480	2,350	8,500	13,000	K 32X37X13	0.018
32	38	26 ^{-0.2/-0.55}	31,500	54,000	3,200	5,550	8,500	13,000	K 32X38X26	0.041
32	39	16 ^{-0.2/-0.55}	22,600	32,000	2,310	3,300	8,500	13,000	K 32X39X16	0.034
32	39	18 ^{-0.2/-0.55}	24,000	35,000	2,450	3,550	8,500	13,000	K 32X39X18	0.037
35	40	13 ^{-0.2/-0.55}	15,200	25,100	1,550	2,560	7,500	11,000	K 35X40X13	0.019
35	40	17 ^{-0.2/-0.55}	20,000	36,000	2,040	3,650	7,500	11,000	K 35X40X17	0.025
35	41	14 ^{-0.2/-0.55}	19,400	30,500	1,980	3,100	7,500	11,000	K 35X41X14	0.026
35	41	15 ^{-0.2/-0.55}	20,900	33,500	2,130	3,400	7,500	11,000	K 35X41X15	0.027
35	42	16 ^{-0.2/-0.55}	24,100	36,000	2,450	3,650	7,500	11,000	K 35X42X16	0.035
35	42	18 ^{-0.2/-0.55}	24,700	37,000	2,510	3,750	7,500	11,000	K 35X42X18	0.039
35	42	20 ^{-0.2/-0.55}	28,500	44,500	2,910	4,550	7,500	11,000	K 35X42X20	0.041
35	42	30 ^{-0.2/-0.55}	39,500	68,000	4,050	6,950	7,500	11,000	K 35X42X30	0.062
37	42	13 ^{-0.2/-0.55}	15,900	27,100	1,620	2,770	7,500	11,000	K 37X42X13	0.021

CAGE AND ROLLER TYPE NEEDLE ROLLER BEARINGS
SERIES K

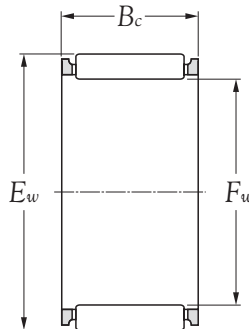

Boundary dimensions			Basic load ratings				Limiting speeds		Bearing numbers	Mass K g (approx.)
mm			dynamic N	static	dynamic K gf	static	rpm			
F_w	E_w	B_c	C_r	C_{or}	C_r	C_{or}	grease	oil		
37	44	18 ^{-0.2/-0.55}	26,300	41,000	2,680	4,150	7,500	11,000	K 37X44X18	0.042
38	43	17 ^{-0.2/-0.55}	20,900	38,500	2,130	3,950	7,500	11,000	K 38X43X17	0.026
38	43	27 ^{-0.2/-0.55}	32,000	67,500	3,300	6,900	7,500	11,000	K 38X43X27	0.043
38	46	32 ^{-0.2/-0.55}	54,000	95,500	5,500	9,700	7,500	11,000	K 38X46X32	0.073
40	45	13 ^{-0.2/-0.55}	16,500	29,200	1,680	2,980	6,500	10,000	K 40X45X13	0.022
40	45	17 ^{-0.2/-0.55}	21,800	41,500	2,220	4,250	6,500	10,000	K 40X45X17	0.027
40	45	21 ^{-0.2/-0.55}	26,700	54,000	2,720	5,500	6,500	10,000	K 40X45X21	0.037
40	45	27 ^{-0.2/-0.55}	33,500	72,500	3,400	7,400	6,500	10,000	K 40X45X27	0.044
40	46	17 ^{-0.2/-0.55}	24,600	43,000	2,500	4,350	6,500	10,000	K 40X46X17	0.030
40	47	18 ^{-0.2/-0.55}	27,700	45,000	2,820	4,550	6,500	10,000	K 40X47X18	0.045
40	47	20 ^{-0.2/-0.55}	31,000	51,500	3,150	5,250	6,500	10,000	K 40X47X20	0.048
40	48	20 ^{-0.2/-0.55}	33,000	51,000	3,350	5,200	6,500	10,000	K 40X48X20	0.052
40	48	25 ^{-0.2/-0.55}	42,500	71,000	4,350	7,250	6,500	10,000	K 40X48X25	0.065
42	47	17 ^{-0.2/-0.55}	22,100	43,000	2,250	4,400	6,500	9,500	K 42X47X17	0.028
42	47	27 ^{-0.2/-0.55}	34,000	75,500	3,450	7,700	6,500	9,500	K 42X47X27	0.047
42	48	17 ^{-0.2/-0.55}	25,700	46,000	2,630	4,700	6,500	9,500	K 42X48X17	0.036
42	50	20 ^{-0.2/-0.55}	34,000	53,500	3,450	5,500	6,500	9,500	K 42X50X20	0.054
43	48	17 ^{-0.2/-0.55}	22,000	43,000	2,240	4,400	6,500	9,500	K 43X48X17	0.029
43	48	27 ^{-0.2/-0.55}	34,000	75,500	3,450	7,700	6,500	9,500	K 43X48X27	0.046
43	50	18 ^{-0.2/-0.55}	29,100	49,000	2,960	5,000	6,500	9,500	K 43X50X18	0.049
45	49	19 ^{-0.2/-0.55}	22,100	52,000	2,260	5,300	6,000	9,000	K 45X49X19	0.027
45	50	27 ^{-0.2/-0.55}	34,500	78,000	3,500	7,950	6,000	9,000	K 45X50X27	0.050
45	52	18 ^{-0.2/-0.55}	29,700	51,000	3,000	5,200	6,000	9,000	K 45X52X18	0.051
45	52	21 ^{-0.2/-0.55}	32,000	56,500	3,300	5,750	6,000	9,000	K 45X52X21	0.061
45	53	20 ^{-0.2/-0.55}	36,000	59,000	3,650	6,000	6,000	9,000	K 45X53X20	0.062
45	53	25 ^{-0.2/-0.55}	46,500	82,000	4,700	8,400	6,000	9,000	K 45X53X25	0.077
47	52	17 ^{-0.2/-0.55}	23,200	47,500	2,360	4,850	5,500	8,500	K 47X52X17	0.033
47	52	27 ^{-0.2/-0.55}	35,500	83,000	3,650	8,450	5,500	8,500	K 47X52X27	0.051

**CAGE AND ROLLER TYPE NEEDLE ROLLER BEARINGS
SERIES K**

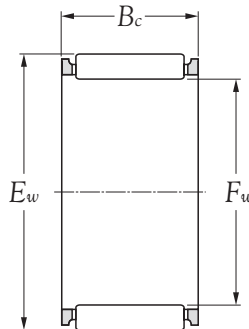

Boundary dimensions			Basic load ratings				Limiting speeds		Bearing numbers	Mass kg (approx.)
mm			dynamic N	static	dynamic kgf	static	rpm			
F_w	E_w	B_c	C_r	C_{or}	C_r	C_{or}	grease	oil		
48	54	19.0 ^{-0.2} _{-0.55}	31,000	61,000	3,150	6,250	5,500	8,500	K 48X54X19	0.044
50	55	13.5 ^{-0.2} _{-0.55}	18,100	35,500	1,850	3,600	5,500	8,000	K 50X55X13.5	0.023
50	55	20.0 ^{-0.2} _{-0.55}	27,900	62,000	2,850	6,300	5,500	8,000	K 50X55X20	0.042
50	55	27.0 ^{-0.2} _{-0.55}	37,000	88,500	3,750	9,000	5,500	8,000	K 50X55X27	0.053
50	55	30.0 ^{-0.2} _{-0.55}	39,500	97,000	4,050	9,900	5,500	8,000	K 50X55X30	0.059
50	57	18.0 ^{-0.2} _{-0.55}	31,500	57,000	3,200	5,800	5,500	8,000	K 50X57X18	0.053
50	58	20.0 ^{-0.2} _{-0.55}	38,500	67,500	3,950	6,850	5,500	8,000	K 50X58X20	0.065
50	58	25.0 ^{-0.2} _{-0.55}	48,500	90,000	4,950	9,150	5,500	8,000	K 50X58X25	0.081
52	58	19.0 ^{-0.2} _{-0.55}	32,000	65,500	3,250	6,650	5,000	7,500	K 52X58X19	0.048
55	60	17.0 ^{-0.2} _{-0.55}	25,800	58,000	2,630	5,900	5,000	7,500	K 55X60X17	0.043
55	60	20.0 ^{-0.2} _{-0.55}	28,800	66,500	2,940	6,750	5,000	7,500	K 55X60X20	0.045
55	60	30.0 ^{-0.2} _{-0.55}	42,000	108,000	4,300	11,000	5,000	7,500	K 55X60X30	0.069
55	61	19.0 ^{-0.2} _{-0.55}	33,000	69,500	3,350	7,100	5,000	7,500	K 55X61X19	0.051
55	61	20.0 ^{-0.2} _{-0.55}	33,000	69,500	3,350	7,100	5,000	7,500	K 55X61X20	0.054
55	61	30.0 ^{-0.2} _{-0.55}	48,000	113,000	4,900	11,500	5,000	7,500	K 55X61X30	0.081
55	62	18.0 ^{-0.2} _{-0.55}	33,500	63,000	3,400	6,450	5,000	7,500	K 55X62X18	0.054
55	63	20.0 ^{-0.2} _{-0.55}	39,000	70,000	3,950	7,100	5,000	7,500	K 55X63X20	0.073
55	63	25.0 ^{-0.2} _{-0.55}	50,500	97,500	5,150	9,950	5,000	7,500	K 55X63X25	0.088
55	63	32.0 ^{-0.2} _{-0.55}	61,000	125,000	6,200	12,700	5,000	7,500	K 55X63X32	0.117
58	64	19.0 ^{-0.2} _{-0.55}	34,000	73,500	3,450	7,500	4,700	7,000	K 58X64X19	0.052
60	65	20.0 ^{-0.2} _{-0.55}	29,800	71,500	3,050	7,300	4,300	6,500	K 60X65X20	0.051
60	65	30.0 ^{-0.2} _{-0.55}	43,500	116,000	4,450	11,800	4,300	6,500	K 60X65X30	0.071
60	66	19.0 ^{-0.2} _{-0.55}	33,500	73,500	3,450	7,500	4,300	6,500	K 60X66X19	0.053
60	66	20.0 ^{-0.2} _{-0.55}	33,500	73,500	3,450	7,500	4,300	6,500	K 60X66X20	0.056
60	66	30.0 ^{-0.2} _{-0.55}	49,000	119,000	5,000	12,200	4,300	6,500	K 60X66X30	0.084
60	68	15.0 ^{-0.2} _{-0.55}	27,200	45,500	2,780	4,650	4,300	6,500	K 60X68X15	0.058
60	68	20.0 ^{-0.2} _{-0.55}	40,000	75,000	4,100	7,650	4,300	6,500	K 60X68X20	0.077
60	68	23.0 ^{-0.2} _{-0.55}	44,500	85,000	4,500	8,700	4,300	6,500	K 60X68X23	0.092

**CAGE AND ROLLER TYPE NEEDLE ROLLER BEARINGS
SERIES K**

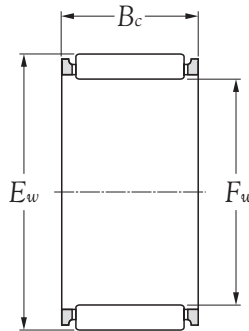

Boundary dimensions			Basic load ratings				Limiting speeds		Bearing numbers	Mass kg (approx.)
mm			dynamic	static	dynamic	static	rpm			
F_w	E_w	B_c	N		kgf		grease	oil		
60	68	25 ^{-0.2} _{-0.55}	52,000	105,000	5,300	10,700	4,300	6,500	K 60X68X25	0.097
60	68	27 ^{-0.2} _{-0.55}	52,000	105,000	5,300	10,700	4,300	6,500	K 60X68X27	0.098
61	66	20 ^{-0.2} _{-0.55}	29,700	71,500	3,050	7,300	4,300	6,500	K 61X66X20	0.054
61	66	30 ^{-0.2} _{-0.55}	43,500	116,000	4,400	11,900	4,300	6,500	K 61X66X30	0.073
63	70	21 ^{-0.2} _{-0.55}	44,500	95,500	4,500	9,700	4,300	6,500	K 63X70X21	0.075
64	70	16 ^{-0.2} _{-0.55}	28,400	60,500	2,900	6,150	4,300	6,500	K 64X70X16	0.053
65	70	20 ^{-0.2} _{-0.55}	30,500	75,000	3,100	7,650	4,000	6,000	K 65X70X20	0.055
65	70	30 ^{-0.2} _{-0.55}	45,000	124,000	4,600	12,700	4,000	6,000	K 65X70X30	0.083
65	73	23 ^{-0.2} _{-0.55}	47,000	94,000	4,800	9,600	4,000	6,000	K 65X73X23	0.100
65	73	30 ^{-0.2} _{-0.55}	61,000	132,000	6,200	13,400	4,000	6,000	K 65X73X30	0.126
68	74	20 ^{-0.2} _{-0.55}	36,000	83,500	3,700	8,550	4,000	6,000	K 68X74X20	0.065
68	74	30 ^{-0.2} _{-0.55}	51,500	133,000	5,250	13,500	4,000	6,000	K 68X74X30	0.097
68	75	21 ^{-0.2} _{-0.55}	45,500	101,000	4,600	10,300	4,000	6,000	K 68X75X21	0.077
70	76	20 ^{-0.2} _{-0.55}	36,500	86,000	3,700	8,750	3,700	5,500	K 70X76X20	0.070
70	76	30 ^{-0.2} _{-0.55}	53,000	139,000	5,400	14,200	3,700	5,500	K 70X76X30	0.100
70	77	21 ^{-0.2} _{-0.55}	45,000	101,000	4,600	10,300	3,700	5,500	K 70X77X21	0.080
70	78	23 ^{-0.2} _{-0.55}	49,500	103,000	5,050	10,500	3,700	5,500	K 70X78X23	0.107
70	78	30 ^{-0.2} _{-0.55}	65,500	149,000	6,700	15,200	3,700	5,500	K 70X78X30	0.136
72	79	21 ^{-0.2} _{-0.55}	46,500	106,000	4,750	10,800	3,700	5,500	K 72X79X21	0.085
73	79	30 ^{-0.2} _{-0.55}	54,500	146,000	5,550	14,900	3,700	5,500	K 73X79X30	0.106
75	81	30 ^{-0.2} _{-0.55}	56,000	152,000	5,700	15,500	3,700	5,500	K 75X81X30	0.108
75	82	21 ^{-0.2} _{-0.55}	46,000	106,000	4,700	10,800	3,700	5,500	K 75X82X21	0.088
75	83	23 ^{-0.2} _{-0.55}	50,500	109,000	5,150	11,100	3,700	5,500	K 75X83X23	0.113
75	83	30 ^{-0.2} _{-0.55}	67,500	157,000	6,850	16,100	3,700	5,500	K 75X83X30	0.147
80	86	20 ^{-0.2} _{-0.55}	39,000	98,000	4,000	10,000	3,300	5,000	K 80X86X20	0.077
80	86	30 ^{-0.2} _{-0.55}	57,000	159,000	5,800	16,200	3,300	5,000	K 80X86X30	0.110
80	88	23 ^{-0.2} _{-0.55}	53,000	118,000	5,400	12,100	3,300	5,000	K 80X88X23	0.125
80	88	26 ^{-0.2} _{-0.55}	61,000	142,000	6,250	14,500	3,300	5,000	K 80X88X26	0.131

CAGE AND ROLLER TYPE NEEDLE ROLLER BEARINGS
SERIES K

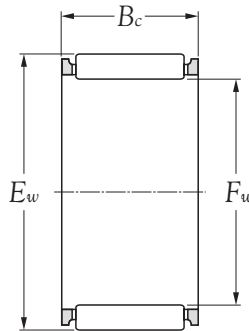

Boundary dimensions			Basic load ratings				Limiting speeds		Bearing numbers	Mass kg (approx.)
mm			dynamic	static	dynamic	static	rpm			
F_w	E_w	B_c	N		kgf		grease	oil		
80	88	30 ^{-0.2/-0.55}	69,000	166,000	7,050	17,000	3,300	5,000	K 80X88X30	0.157
85	92	30 ^{-0.2/-0.55}	66,000	176,000	6,750	18,000	3,100	4,700	K 85X92X30	0.142
85	93	27 ^{-0.2/-0.55}	64,000	153,000	6,500	15,600	3,100	4,700	K 85X93X27	0.145
85	93	30 ^{-0.2/-0.55}	71,000	175,000	7,200	17,900	3,100	4,700	K 85X93X30	0.160
90	97	20 ^{-0.2/-0.55}	46,000	113,000	4,700	11,500	2,900	4,400	K 90X97X20	0.103
90	97	30 ^{-0.2/-0.55}	67,500	184,000	6,850	18,700	2,900	4,400	K 90X97X30	0.151
90	98	26 ^{-0.2/-0.55}	64,000	157,000	6,550	16,000	2,900	4,400	K 90X98X26	0.148
90	98	27 ^{-0.2/-0.55}	64,000	157,000	6,550	16,000	2,900	4,400	K 90X98X27	0.150
90	98	30 ^{-0.2/-0.55}	72,500	184,000	7,400	18,800	2,900	4,400	K 90X98X30	0.172
95	102	21 ^{-0.2/-0.55}	48,000	122,000	4,900	12,400	2,800	4,200	K 95X102X21	0.115
95	102	31 ^{-0.2/-0.55}	70,500	199,000	7,200	20,300	2,800	4,200	K 95X102X31	0.172
95	103	27 ^{-0.2/-0.55}	65,500	165,000	6,700	16,800	2,800	4,200	K 95X103X27	0.159
95	103	30 ^{-0.2/-0.55}	74,000	193,000	7,550	19,600	2,800	4,200	K 95X103X30	0.165
100	107	21 ^{-0.3/-0.65}	49,000	127,000	5,000	12,900	2,700	4,000	K 100X107X21	0.120
100	107	31 ^{-0.3/-0.65}	71,500	207,000	7,300	21,100	2,700	4,000	K 100X107X31	0.173
100	108	27 ^{-0.3/-0.65}	61,000	153,000	6,250	15,600	2,700	4,000	K 100X108X27	0.176
100	108	30 ^{-0.3/-0.65}	76,000	201,000	7,700	20,500	2,700	4,000	K 100X108X30	0.190
105	112	21 ^{-0.3/-0.65}	48,500	127,000	4,950	12,900	2,500	3,800	K 105X112X21	0.130
105	112	31 ^{-0.3/-0.65}	71,000	207,000	7,250	21,100	2,500	3,800	K 105X112X31	0.176
105	113	30 ^{-0.3/-0.65}	77,500	210,000	7,900	21,400	2,500	3,800	K 105X113X30	0.198
110	117	24 ^{-0.3/-0.65}	54,500	149,000	5,550	15,200	2,400	3,600	K 110X117X24	0.145
110	117	34 ^{-0.3/-0.65}	77,500	235,000	7,900	24,000	2,400	3,600	K 110X117X34	0.205
110	118	30 ^{-0.3/-0.65}	79,000	219,000	8,050	22,300	2,400	3,600	K 110X118X30	0.217
115	123	27 ^{-0.3/-0.65}	64,000	170,000	6,550	17,300	2,300	3,500	K 115X123X27	0.200
115	125	34 ^{-0.3/-0.65}	95,000	241,000	9,700	24,600	2,300	3,500	K 115X125X34	0.330
120	127	24 ^{-0.3/-0.65}	57,500	165,000	5,850	16,800	2,200	3,300	K 120X127X24	0.160
120	127	34 ^{-0.3/-0.65}	82,000	260,000	8,350	26,600	2,200	3,300	K 120X127X34	0.235
125	133	35 ^{-0.3/-0.65}	87,000	260,000	8,900	26,500	2,100	3,200	K 125X133X35	0.275

**CAGE AND ROLLER TYPE NEEDLE ROLLER BEARINGS
SERIES K**

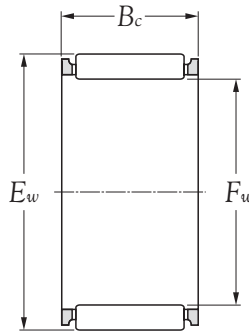

Boundary dimensions			Basic load ratings				Limiting speeds		Bearing numbers	Mass kg (approx.)
mm			dynamic	static	dynamic	static	rpm			
F_w	E_w	B_c	N		kgf		grease	oil		
125	135	34 ^{-0.3/-0.65}	100,000	265,000	10,200	27,000	2,100	3,200	K 125X135X34	0.350
130	137	24 ^{-0.3/-0.65}	59,000	175,000	6,000	17,900	2,100	3,100	K 130X137X24	0.170
130	137	34 ^{-0.3/-0.65}	84,500	277,000	8,600	28,300	2,100	3,100	K 130X137X34	0.240
135	143	35 ^{-0.3/-0.65}	92,500	288,000	9,450	29,400	2,000	3,000	K 135X143X35	0.300
135	150	38 ^{-0.3/-0.65}	145,000	325,000	14,800	33,500	2,000	3,000	K 135X150X38	0.590
145	153	26 ^{-0.3/-0.65}	72,000	214,000	7,350	21,800	1,900	2,800	K 145X153X26	0.250
145	153	28 ^{-0.3/-0.65}	80,500	247,000	8,200	25,200	1,900	2,800	K 145X153X28	0.252
145	153	36 ^{-0.3/-0.65}	100,000	325,000	10,200	33,000	1,900	2,800	K 145X153X36	0.335
150	160	46 ^{-0.3/-0.65}	149,000	470,000	15,200	48,000	1,800	2,700	K 150X160X46	0.550
155	163	26 ^{-0.3/-0.65}	73,500	224,000	7,500	22,800	1,700	2,600	K 155X163X26	0.270
155	163	36 ^{-0.3/-0.65}	102,000	340,000	10,400	34,500	1,700	2,600	K 155X163X36	0.355
160	170	46 ^{-0.3/-0.65}	155,000	505,000	15,800	51,500	1,700	2,500	K 160X170X46	0.570
165	173	26 ^{-0.3/-0.65}	79,000	251,000	8,050	25,600	1,600	2,400	K 165X173X26	0.290
165	173	32 ^{-0.3/-0.65}	97,000	330,000	9,900	33,500	1,600	2,400	K 165X173X32	0.340
165	173	36 ^{-0.3/-0.65}	109,000	380,000	11,100	39,000	1,600	2,400	K 165X173X36	0.375
170	180	46 ^{-0.3/-0.65}	160,000	540,000	16,400	55,000	1,600	2,400	K 170X180X46	0.620
175	183	32 ^{-0.3/-0.65}	101,000	350,000	10,300	35,500	1,500	2,300	K 175X183X32	0.360
185	195	37 ^{-0.3/-0.65}	131,000	425,000	13,300	43,500	1,500	2,200	K 185X195X37	0.560
195	205	37 ^{-0.3/-0.65}	135,000	450,000	13,800	46,000	1,400	2,100	K 195X205X37	0.620
210	220	42 ^{-0.3/-0.65}	156,000	560,000	15,900	57,000	1,300	1,900	K 210X220X42	0.740
220	230	42 ^{-0.3/-0.65}	161,000	590,000	16,400	60,000	1,200	1,800	K 220X230X42	0.790
240	250	42 ^{-0.3/-0.65}	167,000	635,000	17,000	64,500	1,100	1,700	K 240X250X42	0.850
265	280	50 ^{-0.3/-0.65}	256,000	850,000	26,100	87,000	1,000	1,500	K 265X280X50	1.810
285	300	50 ^{-0.3/-0.65}	268,000	930,000	27,300	94,500	950	1,400	K 285X300X50	1.970



NOTE

AUTOMATION TECHNOLOGY



DRAWN CUP NEEDLE ROLLER BEARINGS

1. Types and designs

NIKO Drawn Cup Needle Roller Bearings can be classified into open-end and closed-end types according to the form of their outer ring.

The open-end design is further subcategorized into the series HK (metric standard series).

The closed-end design is further classified into series BK (metric standard series).

Sealed **NIKO** Drawn Cup Needle Roller Bearings (suffix L or LL) having a synthetic rubber seal on one or both ends are pre-filled with lithium soap grease. The allowable operating temperature range with this bearing variant is -25°C to +100°C. Its rollers are shorter than those in an open-ended type of the same dimension, so its load rating is accordingly smaller.

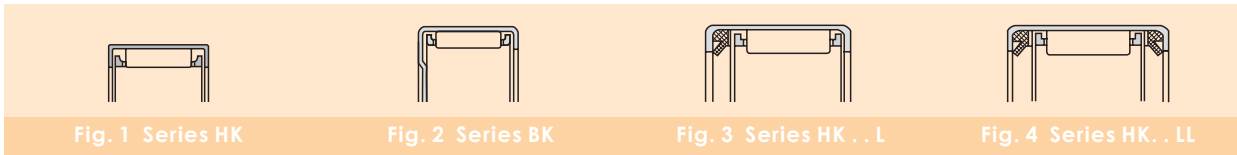

The cages used for drawn cup needle roller bearings are usually pressed-steel cages. Also, certain small drawn cup needle roller bearings use molded polyamide cages reinforced with glass fiber or carbon fiber (suffix T2). The T2 cage features a maximum allowable operating temperature of 120°C and a maximum allowable continuous operating temperature of 100°C .

2. Interpreting bearing numbers

As summarized in Fig. 5, the bearing numbers of **NIKO** Drawn Cup Needle Roller Bearings comprise a series number, dimension code (inscribed enveloping circle diameter×width dimension), and suffix.

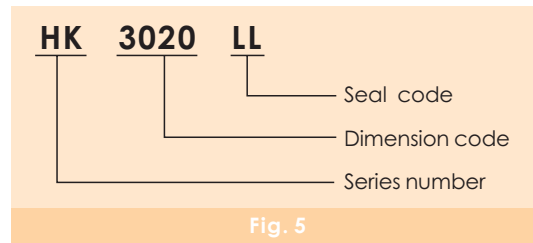

3. Bearing fits

The fit of an **NIKO** Drawn Cup Needle Roller Bearing to a housing is usually a tight fit where the inscribed enveloping circle diameter (F_w) of press-fit rollers satisfies ISO tolerance class F8. However, the inscribed enveloping circle diameter (F_w) of press-fit rollers varies with the material and rigidity of the housing. Therefore, actual bearing fit (interference) should be measured and determined through trials before the bearing is mounted.

If a housing has sufficient rigidity, selecting a fit to housing or shaft from Table 1 can result in an inscribed enveloping circle diameter (F_w) of press-fit rollers close to F8 and a radial clearance close to normal clearance.

Table 1 Fit to housing and shaft

Series number	Housing		Shaft	
	Steel	Light alloy	Without inner ring	With inner ring
HK,BK	N6(N7)	R6(R7)	h5(h6)	k5(j6)

4. Housing bore accuracy

Because the outer ring has a thinner wall, the performance of drawn cup needle roller bearings is significantly affected by the surface roughness and the dimensional and form accuracy of the housing bore to which a bearing is press-fit. The housing bore must satisfy the accuracy of Table 2.

Table 2 Recommended fits

Characteristics	Tolerance
Circularity (max.)	IT4 or less
Cylindricity (max.)	IT4 or less
Surface roughness (max.)	1.6a

5. Bearing tolerances and measuring methods

The outer ring of a drawn cup needle roller bearing is thin-walled. Therefore, some deformation of the outer ring unavoidably develops during the manufacturing process, particularly during heat treatment. However, when the outer ring is press-fit into a correctly dimensioned housing, the deformation is corrected, restoring the design functions of the outer ring. For this reason, measuring the dimensional accuracy of a drawn cup needle roller bearing before it is press-fit is meaningless. Therefore, its accuracy is evaluated by measuring its inscribed enveloping circle diameter (*F_w*) after it has been press-fit into a ring gauge of correct dimensions (wall thickness 20 mm or greater).

The tolerances of the bore diameter of the ring gauges and the inscribed enveloping circle diameter (*F_w*) are given in Tables 3, which apply to the series HK and BK (standard metric series). When measuring the inscribed enveloping circle diameter (*F_w*) with a plug gauge, the dimension at GO side must satisfy "Low" tolerance for inscribed enveloping circle diameter, and that at NO GO side must satisfy "Height" tolerance plus 2 μm. These values comply with the relevant ISO standard.

Table 3 Enveloping circle diameter tolerance (series HK and BK) (Unit: mm)

Enveloping circle dia. <i>F_w</i>	Outside dia. of outer ring <i>D</i>	Ring gauge bore dia.	Enveloping circle dia. tolerance	
			high	low
3	6.5	6.4840	3.016	3.006
4	8	7.9840	4.022	4.010
5	9	8.9840	5.022	5.010
6	10	9.9840	6.022	6.010
7	11	10.980	7.028	7.013
8	12	11.980	8.028	8.013
9	13	12.980	9.028	9.013
10	14	13.980	10.028	10.013
12	16	15.980	12.034	12.016
12	18	17.980	12.034	12.016
13	19	18.976	13.034	13.016
14	20	19.976	14.034	14.016
15	21	20.976	15.034	15.016
16	22	21.976	16.034	16.016
17	23	22.976	17.034	17.016
18	24	23.976	18.034	18.016
20	26	25.976	20.041	20.020
22	28	27.976	22.041	22.020
25	32	31.972	25.041	25.020
28	35	34.972	28.041	28.020
30	37	36.972	30.041	30.020
35	42	41.972	35.050	35.025
40	47	46.972	40.050	40.025
45	52	51.967	45.050	45.025
50	58	57.967	50.050	50.025
55	63	62.967	55.060	55.030
60	68	67.967	60.060	60.030

**DRAWN CUP NEEDLE ROLLER BEARINGS
SERIES HK.., BK..**

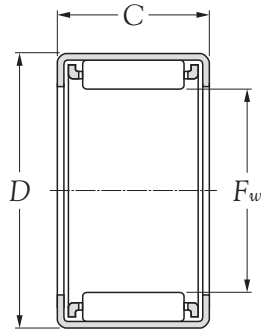

Type HK

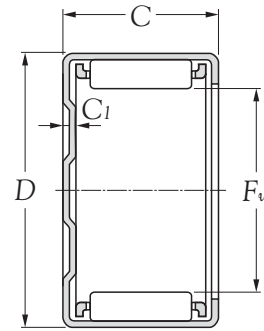

Type BK

Boundary dimensions				Basic load ratings				Limiting speeds		Bearing numbers		Mass	Appropriate inner ring
F _w	mm			dynamic	static	dynamic	static	rpm		Open end design	Closed end design	kg (approx.)	(as a reference)
	D	C _{0-0.2}	C _{1 max}	N	N	kgf	kgf	grease	oil				
3	6.5	6	-	1,250	835	128	85	33,000	50,000	HK 0306	-	0.0006	-
3	6.5	6	0.8	1,250	835	128	85	33,000	50,000	-	BK 0306	0.0007	-
4	8.0	8	-	1,770	1,270	180	129	30,000	45,000	HK 0408	-	0.0016	-
4	8.0	8	1.6	1,770	1,270	180	129	30,000	45,000	-	BK 0408	0.0018	-
5	9.0	9	-	2,640	2,190	269	224	27,000	40,000	HK 0509	-	0.0019	-
5	9.0	9	1.6	2,640	2,190	269	224	27,000	40,000	-	BK 0509	0.0021	-
6	10.0	9	-	2,660	2,280	272	233	25,000	37,000	HK 0609	-	0.0022	-
6	10.0	9	1.6	2,660	2,280	272	233	25,000	37,000	-	BK 0609	0.0024	-
7	11.0	9	-	3,400	3,250	345	330	23,000	34,000	HK 0709	-	0.0025	-
7	11.0	9	1.6	3,400	3,250	345	330	23,000	34,000	-	BK 0709	0.0027	-
8	12.0	10	-	3,850	3,950	395	400	20,000	30,000	HK 0810	-	0.0032	IR 5X8X12
8	12.0	10	1.6	3,850	3,950	395	400	20,000	30,000	-	BK 0810	0.0034	IR 5X8X12
9	13.0	10	-	4,600	5,050	465	515	18,000	27,000	HK 0910	-	0.0035	IR 6X9X12
9	13.0	10	1.6	4,600	5,050	465	515	18,000	27,000	-	BK 0910	0.0039	IR 6X9X12
9	13.0	12	-	5,650	6,650	575	680	18,000	27,000	HK 0912	-	0.0042	IR 6X9X12
9	13.0	12	1.6	5,650	6,650	575	680	18,000	27,000	-	BK 0912	0.0045	IR 6X9X12
10	14.0	10	-	4,500	5,100	460	520	16,000	24,000	HK 1010	-	0.0038	IR 7X10X10.5
10	14.0	10	1.6	4,500	5,100	460	520	16,000	24,000	-	BK 1010	0.0042	IR 7X10X10.5
10	14.0	12	-	5,900	7,250	605	735	16,000	24,000	HK 1012	-	0.0045	IR 7X1X16
10	14.0	12	1.6	5,900	7,250	605	735	16,000	24,000	-	BK 1012	0.0050	IR 7X10X16
10	14.0	15	-	7,100	9,150	725	935	16,000	24,000	HK 1015	-	0.0056	IR 7X10X16
10	14.0	15	1.6	7,100	9,150	725	935	16,000	24,000	-	BK 1015	0.0062	IR 7X10X16
12	16.0	10	-	5,050	6,250	515	635	13,000	20,000	HK 1210	-	0.0046	IR 8X12X10.5
12	16.0	10	1.6	5,050	6,250	515	635	13,000	20,000	-	BK 1210	0.0052	IR 8X12X10.5
12	18.0	12	-	6,600	7,300	675	745	13,000	20,000	HK 1212	-	0.0091	IR 8X12X12.5
12	18.0	12	2.7	6,600	7,300	675	745	13,000	20,000	-	BK 1212	0.0100	IR 8X12X12.5
13	19.0	12	-	7,300	8,450	745	865	12,000	18,000	HK 1312	-	0.0100	IR10X13X12.5
13	19.0	12	2.7	7,300	8,450	745	865	12,000	18,000	-	BK 1312	0.0110	IR10X13X12.5

**DRAWN CUP NEEDLE ROLLER BEARINGS
SERIES HK., BK..**

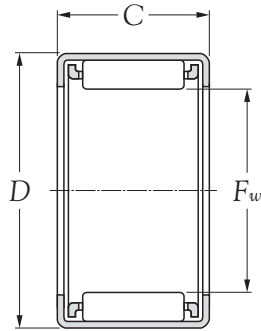

Type HK

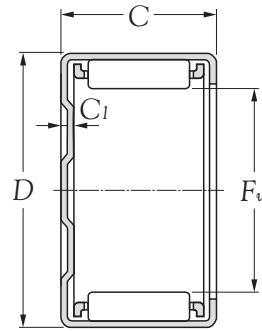

Type BK

Boundary dimensions				Basic load ratings				Limiting speeds		Bearing numbers		Mass	Appropriate inner ring
F _w	mm			dynamic	static	dynamic	static	rpm		Open end design	Closed end design	kg (approx.)	(as a reference)
	D	C _{0-0.2}	C _{1 max}	N	N	kgf	kgf	grease	oil				
14	20	12	-	7,200	8,500	735	865	11,000	17,000	HK 1412	-	0.011	IR 10X14X13
14	20	12	2.7	7,200	8,500	735	865	11,000	17,000	-	BK 1412	0.012	IR 10X14X13
14	20	16	-	10,700	14,000	1,090	1,430	11,000	17,000	HK 1416	-	0.015	-
14	20	16	2.7	10,700	14,000	1,090	1,430	11,000	17,000	-	BK 1416	0.016	-
15	21	12	-	7,500	9,100	765	930	11,000	16,000	HK 1512	-	0.011	IR 12X15X12.5
15	21	12	2.7	7,500	9,100	765	930	11,000	16,000	-	BK 1512	0.013	IR 12X15X12.5
15	21	16	-	10,700	14,400	1,090	1,470	11,000	16,000	HK 1516	-	0.015	IR 12X15X16.5
15	21	16	2.7	10,700	14,400	1,090	1,470	11,000	16,000	-	BK 1516	0.017	IR 12X15X16.5
16	22	12	-	7,750	9,700	795	990	10,000	15,000	HK 1612	-	0.012	IR 12X16X13
16	22	12	2.7	7,750	9,700	795	990	10,000	15,000	-	BK 1612	0.014	IR 12X16X13
16	22	16	-	11,100	15,300	1,130	1,570	10,000	15,000	HK 1616	-	0.016	IR 12X16X20
16	22	16	2.7	11,100	15,300	1,130	1,570	10,000	15,000	-	BK 1616	0.018	IR 12X16X20
17	23	12	-	8,500	11,100	865	1,130	9,500	14,000	HK 1712	-	0.012	-
17	23	12	2.7	8,500	11,100	865	1,130	9,500	14,000	-	BK 1712	0.015	-
18	24	12	-	8,300	10,900	845	1,110	8,500	13,000	HK 1812	-	0.013	IR 15X18X12.5
18	24	12	2.7	8,300	10,900	845	1,110	8,500	13,000	-	BK 1812	0.015	IR 15X18X12.5
18	24	16	-	11,800	17,300	1,210	1,760	8,500	13,000	HK 1816	-	0.018	IR 15X18X16.5
18	24	16	2.7	11,800	17,300	1,210	1,760	8,500	13,000	-	BK 1816	0.020	IR 15X18X16.5
20	26	12	-	9,250	13,000	945	1,330	8,000	12,000	HK 2012	-	0.014	IR 15X20X13
20	26	12	2.7	9,250	13,000	945	1,330	8,000	12,000	-	BK 2012	0.017	IR 15X20X13
20	26	16	-	13,000	20,100	1,320	2,050	8,000	12,000	HK 2016	-	0.019	IR 17X20X16.5
20	26	16	2.7	13,000	20,100	1,320	2,050	8,000	12,000	-	BK 2016	0.022	IR 17X20X16.5
20	26	20	-	16,400	27,100	1,670	2,760	8,000	12,000	HK 2020	-	0.024	IR 17X20X20.5
20	26	20	2.7	16,400	27,100	1,670	2,760	8,000	12,000	-	BK 2020	0.027	IR 17X20X20.5
22	28	12	-	9,750	14,300	995	1,460	7,500	11,000	HK 2212	-	0.013	IR 17X22X13
22	28	12	2.7	9,750	14,300	995	1,460	7,500	11,000	-	BK 2212	0.015	IR 17X22X13
22	28	16	-	13,600	22,100	1,390	2,250	7,500	11,000	HK 2216	-	0.021	IR 17X22X18
22	28	16	2.7	13,600	22,100	1,390	2,250	7,500	11,000	-	BK 2216	0.024	IR 17X22X18

**DRAWN CUP NEEDLE ROLLER BEARINGS
SERIES HK.., BK..**

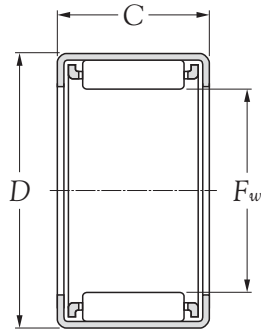

Type HK

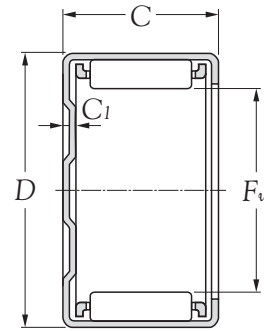

Type BK

Boundary dimensions				Basic load ratings				Limiting speeds		Bearing numbers		Mass	Appropriate inner ring
F _w	mm			dynamic	static	dynamic	static	rpm		Open end design	Closed end design	kg (approx.)	(as a reference)
	D	C _{0-0.2}	C _{1 max}	N	N	kgf	kgf	grease	oil				
22	28	20	-	17,200	29,800	1,760	3,050	7,500	11,000	HK 2220	-	0.026	IR 17X22X20.5
22	28	20	2.7	17,200	29,800	1,760	3,050	7,500	11,000	-	BK 2220	0.030	IR 17X22X20.5
25	32	12	-	11,800	16,300	1,200	1,660	6,500	9,500	HK 2512	-	0.021	IR 20X25X12.5
25	32	12	2.7	11,800	16,300	1,200	1,660	6,500	9,500	-	BK 2512	0.023	IR 20X25X12.5
25	32	16	-	15,900	24,000	1,620	2,450	6,500	9,500	HK 2516	-	0.027	IR 20X25X17
25	32	16	2.7	15,900	24,000	1,620	2,450	6,500	9,500	-	BK 2516	0.031	IR 20X25X17
25	32	20	-	20,300	33,000	2,070	3,350	6,500	9,500	HK 2520	-	0.034	IR 20X25X20.5
25	32	20	2.7	20,300	33,000	2,070	3,350	6,500	9,500	-	BK 2520	0.039	IR 20X25X20.5
25	32	26	-	26,400	46,000	2,690	4,700	6,500	9,500	HK 2526	-	0.045	IR 20X25X26.5
25	32	26	2.7	26,400	46,000	2,690	4,700	6,500	9,500	-	BK 2526	0.049	IR 20X25X26.5
28	35	16	-	17,300	27,600	1,760	2,820	5,500	8,500	HK 2816	-	0.030	IR 22X28X17
28	35	16	2.7	17,300	27,600	1,760	2,820	5,500	8,500	-	BK 2816	0.034	IR 22X28X17
28	35	20	-	21,300	36,000	2,170	3,700	5,500	8,500	HK 2820	-	0.038	IR 22X28X20.5
28	35	20	2.7	21,300	36,000	2,170	3,700	5,500	8,500	-	BK 2820	0.043	IR 22X28X20.5
30	37	12	-	13,000	19,500	1,320	1,990	5,500	8,000	HK 3012	-	0.024	IR 25X30X12.5
30	37	12	2.7	13,000	19,500	1,320	1,990	5,500	8,000	-	BK 3012	0.028	IR 25X30X12.5
30	37	16	-	18,100	30,000	1,850	3,050	5,500	8,000	HK 3016	-	0.032	IR 25X30X17
30	37	16	2.7	18,100	30,000	1,850	3,050	5,500	8,000	-	BK 3016	0.037	IR 25X30X17
30	37	20	-	22,300	39,500	2,280	4,000	5,500	8,000	HK 3020	-	0.040	IR 25X30X20.5
30	37	20	2.7	22,300	39,500	2,280	4,000	5,500	8,000	-	BK 3020	0.047	IR 25X30X20.5
30	37	26	-	29,100	55,000	2,960	5,650	5,500	8,000	HK 3026	-	0.053	IR 25X30X26.5
30	37	26	2.7	29,100	55,000	2,960	5,650	5,500	8,000	-	BK 3026	0.059	IR 25X30X26.5
35	42	12	-	14,000	22,800	1,430	2,320	4,700	7,000	HK 3512	-	0.028	-
35	42	12	2.7	14,000	22,800	1,430	2,320	4,700	7,000	-	BK 3512	0.033	-
35	42	16	-	19,700	35,000	2,000	3,600	4,700	7,000	HK 3516	-	0.037	-
35	42	16	2.7	19,700	35,000	2,000	3,600	4,700	7,000	-	BK 3516	0.044	-
35	42	20	-	24,800	47,500	2,530	4,850	4,700	7,000	HK 3520	-	0.046	-
35	42	20	2.7	24,800	47,500	2,530	4,850	4,700	7,000	-	BK 3520	0.055	-

**DRAWN CUP NEEDLE ROLLER BEARINGS
SERIES HK.., BK..**

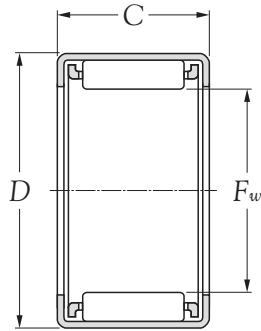

Type HK

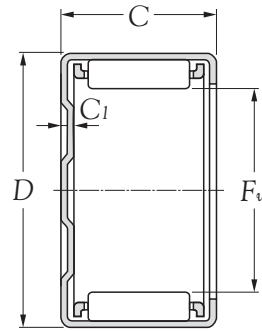

Type BK

Boundary dimensions				Basic load ratings				Limiting speeds		Bearing numbers		Mass	Appropriate inner ring
F _w	mm			dynamic	static	dynamic	static	rpm		Open end design	Closed end design	kg (approx.)	(as a reference)
	D	C ₀ -0.2	C ₁ max	N	N	kgf	kgf	grease	oil				
40	47	12	-	15,100	26,000	1,540	2,660	4,000	6,000	HK 4012	-	0.031	IR 35X40X12.5
40	47	12	2.7	15,100	26,000	1,540	2,660	4,000	6,000	-	BK 4012	0.038	IR 35X40X12.5
40	47	16	-	21,100	40,000	2,150	4,100	4,000	6,000	HK 4016	-	0.041	IR 35X40X17
40	47	16	2.7	21,100	40,000	2,150	4,100	4,000	6,000	-	BK 4016	0.051	IR 35X40X17
40	47	20	-	25,900	52,500	2,650	5,350	4,000	6,000	HK 4020	-	0.052	IR 35X40X20.5
40	47	20	2.7	25,900	52,500	2,650	5,350	4,000	6,000	-	BK 4020	0.064	IR 35X40X20.5
45	52	16	-	21,600	43,000	2,210	4,400	3,700	5,500	HK 4516	-	0.046	IR 40X45X17
45	52	16	2.7	21,600	43,000	2,210	4,400	3,700	5,500	-	BK 4516	0.058	IR 40X45X17
45	52	20	-	27,600	59,000	2,810	6,000	3,700	5,500	HK 4520	-	0.058	IR 40X45X20.5
45	52	20	2.7	27,600	59,000	2,810	6,000	3,700	5,500	-	BK 4520	0.072	IR 40X45X20.5
50	58	20	-	31,500	63,000	3,200	6,450	3,200	4,800	HK 5020	-	0.072	IR 40X50X22
50	58	20	2.7	31,500	63,000	3,200	6,450	3,200	4,800	-	BK 5020	0.087	IR 40X50X22
50	58	25	-	38,500	82,000	3,900	8,400	3,200	4,800	HK 5025	-	0.090	IR 45X50X25.5
50	58	25	2.7	38,500	82,000	3,900	8,400	3,200	4,800	-	BK 5025	0.109	IR 45X50X25.5

DRAWN CUP NEEDLE ROLLER BEARINGS SEALED TYPE
SERIES HK..L, HK..LL, BK..L

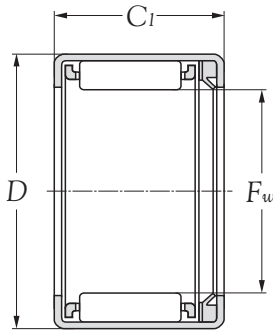

Type HK..L
(Open end. single seal)

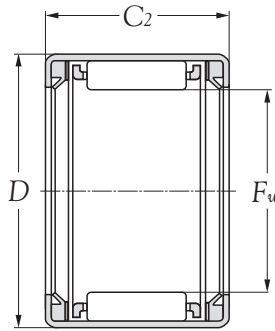

Type HK..LL
(Open end. single seal)

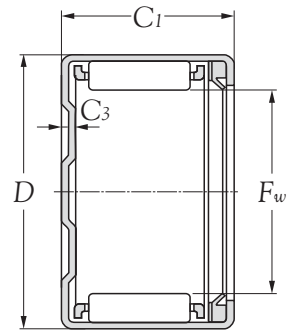

Type BK..L
(Closed end. single seal)

Boundary dimensions					Basic load ratings				Limiting speeds	Bearing numbers			
F _w	D	mm			dynamic	static	dynamic	static	rpm	grease	open end single seal	oen end double seal	closed end single seal
		C ₁ 0 -0.02	C ₂ 0 -0.02	C ₃ max	N	kgf	C _r	C _{or}					
12	18	14	16	2.7	6,600	7,300	675	745	10,000	HK 1214 L	HK 1216 LL	BK 1214 L	
14	20	14	16	2.7	7,200	8,500	735	865	10,000	HK 1414 L	HK 1416 LL	BK 1414 L	
15	21	14	16	2.7	7,500	9,100	765	930	10,000	HK 1514 L	HK 1516 LL	BK 1514 L	
16	22	14	16	2.7	7,750	9,700	795	990	10,000	HK 1614 L	HK 1616 LL	BK 1614 L	
18	24	14	16	2.7	8,300	10,900	845	1,110	9,000	HK 1814 L	HK 1816 LL	BK 1814 L	
20	26	-	16	-	9,250	13,000	945	1,330	8,000	-	HK 2016 LL	-	
20	26	18	20	2.7	13,000	20,100	1,320	2,050	8,000	HK 2018 L	HK 2020 LL	BK 2018 L	
22	28	-	16	-	9,750	14,300	995	1,460	7,500	-	HK 2216 LL	-	
22	28	18	20	2.7	13,600	22,100	1,390	2,250	7,500	HK 2218 L	HK 2220 LL	BK 2218 L	
25	32	-	16	-	11,800	16,300	1,200	1,660	6,500	-	HK 2516 LL	-	
25	32	18	20	2.7	15,900	24,000	1,620	2,450	6,500	HK 2518 L	HK 2520 LL	BK 2518 L	
28	35	-	20	-	17,300	27,600	1,760	2,820	5,500	-	HK 2820 LL	-	
30	37	-	16	-	13,000	19,500	1,320	1,990	5,500	-	HK 3016 LL	-	
30	37	18	20	2.7	18,100	30,000	1,850	3,050	5,500	HK 3018 L	HK 3020 LL	BK 3018 L	
35	42	-	16	-	14,000	22,800	1,430	2,320	4,600	-	HK 3516 LL	-	
35	42	18	20	2.7	19,700	35,000	2,000	3,600	4,600	HK 3518 L	HK 3520 LL	BK 3518 L	
40	47	-	16	-	15,100	26,000	1,540	2,660	4,000	-	HK 4016 LL	-	
40	47	18	20	2.7	21,100	40,000	2,150	4,100	4,000	HK 4018 L	HK 4020 LL	BK 4018 L	
45	52	18	20	2.7	21,600	43,000	2,210	4,400	3,600	HK 4518 L	HK 4520 LL	BK 4518 L	
50	58	22	24	2.7	31,500	63,000	3,200	6,450	3,200	HK 5022 L	HK 5024 LL	BK 5022 L	

DRAWN CUP NEEDLE ROLLER BEARINGS SEALED TYPE
SERIES HK..L, HK..LL, BK..L

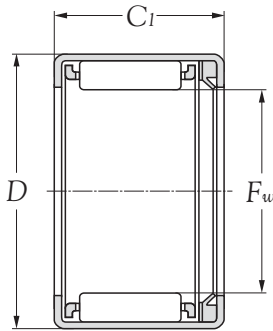

Type HK..L
(Open end. single seal)

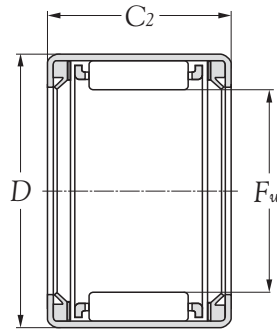

Type HK..LL
(Open end. single seal)

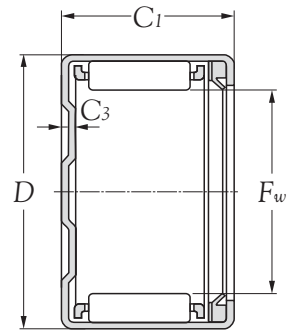

Type BK..L
(Closed end. single seal)

Appropriate inner ring (as a reference)		Bearing numbers			Mass kg (approx.)		
single seal	double seal	open end single seal	oen end double seal	closed end single seal	open end single seal	oen end double seal	closed end single seal
IR 9×12×16	-	HK 1214 L	HK 1216 LL	BK 1214 L	11	0.012	12
IR 10×14×16	IR 10×14×20	HK 1414 L	HK 1416 LL	BK 1414 L	12	0.014	14
IR 12×15×16.5	IR 12×15×16.5	HK 1514 L	HK 1516 LL	BK 1514 L	13	0.014	14
IR 12×16×16	IR 12×16×20	HK 1614 L	HK 1616 LL	BK 1614 L	13	0.015	15
IR 15×18×16	IR 15×18×17.5	HK 1814 L	HK 1816 LL	BK 1814 L	15	0.017	17
-	IR 15×20×18	-	HK 2016 LL	-	-	0.019	-
IR 17×20×20	IR 17×20×20.5	HK 2018 L	HK 2020 LL	BK 2018 L	21	0.024	24
-	IR 17×22×18	-	HK 2216 LL	-	-	0.020	-
IR 17×22×20.5	IR 17×22×23	HK 2218 L	HK 2220 LL	BK 2218 L	24	0.026	27
-	IR 20×25×18D	-	HK 2516 LL	-	-	0.027	-
IR 20×25×20	IR 20×25×23	HK 2518 L	HK 2520 LL	BK 2518 L	31	0.033	35
-	IR 22×28×23	-	HK 2820 LL	-	-	0.037	-
-	IR 25×30×18D	-	HK 3016 LL	-	-	0.027	-
IR 25×30×20	IR 25×30×23	HK 3018 L	HK 3020 LL	BK 3018 L	37	0.039	45
-	-	-	HK 3516 LL	-	-	0.036	-
-	-	HK 3518 L	HK 3520 LL	BK 3518 L	37	0.040	47
-	IR 35×40×17	-	HK 4016 LL	-	-	0.041	-
IR 35×40×20	-	HK 4018 L	HK 4020 LL	BK 4018 L	47	0.050	62
IR 40×45×20	-	HK 4518 L	HK 4520 LL	BK 4518 L	54	0.057	72
IR 45×50×25	IR 45×50×25.5	HK 5022 L	HK 5024 LL	BK 5022 L	86	0.089	104



MACHINED-RING NEEDLE ROLLER BEARINGS

1. Types and designs

The available **NIKO** Machined Ring Needle Roller Bearings, without an inner ring, include the series NK and RNA (metric series) The dimension series of the series RNA includes the RNA49, RNA59, and RNA69. The bearing series with an inner ring include NKI and NA (metric series) The dimension series of series NA include NA48, NA49, NA59, and NA69. The boundary dimensions (bore diameter, outside diameter, width, and chamfer dimension) for these dimension series are specified in JIS B 1512 and ISO 15. The third and fourth significant numerals in their bearing numbers represent width number and diameter number, respectively. Particular bearings, whose inscribed enveloping circle diameter is 40 mm or greater, among the RNA69 (NA69) bearings have double-row needle rollers, while bearings of other models and dimension series have single-row needle rollers. With bearings whose inscribed enveloping circle diameter (F_w) does not exceed 12 mm, the needle rollers and cage are retained in the outer ring by the side plate: in the case of the inscribed enveloping circle diameter (F_w) exceeding 12 mm, the needle rollers and cage are retained in the outer ring by the rib. The outer rings (other than those of series NK bearings whose inscribed enveloping circle diameter does not exceed 12 mm) have a lubrication hole and oil groove to simplify relubrication of the bearing.

The cage used on **NIKO** Machined Ring Needle Roller Bearings is usually a machined or pressed-steel type. However, cages of molded polyamide reinforced with glass fiber or carbon fiber (suffix T2) may be used. The T2 cage features a maximum allowable operating temperature of 120°C and maximum allowable continuous operating temperature of 100°C . Series RNA49 (NA49) bearings include a sealed type whose outer ring has a synthetic rubber seal on one or both ends (suffix L, LL). This variant is pre-filled with lithium soap grease and can operate within a temperate range of -25°C to 100°C.

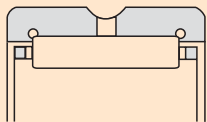

Fig. 1 Series RNA(NK)

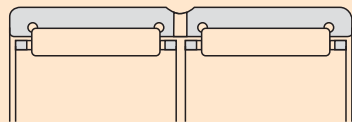

Fig. 2 Series RNA(double row)

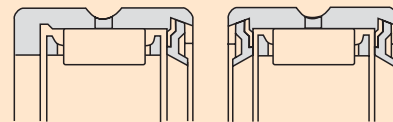

Fig. 3 Series RNA49..L(LL)

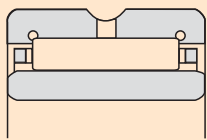

Fig. 4 Series NA

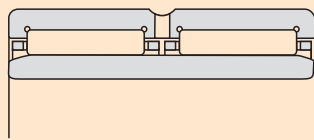

Fig. 5 Series NA(double row)

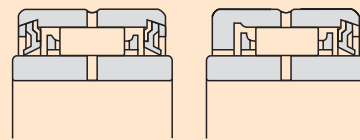
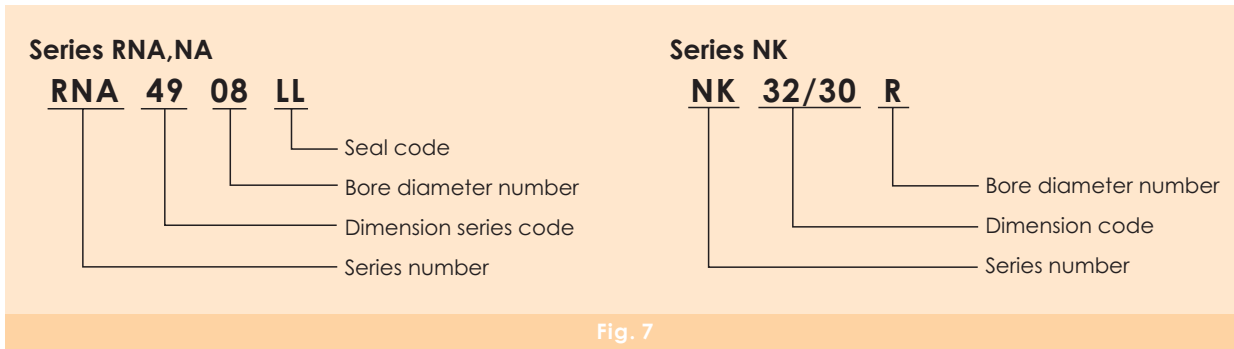

Fig. 6 Series NA49..L(LL)

2. Interpreting bearing numbers

The bearing numbers of **NIKO** Machined Ring Needle Roller Bearings, series RNA and NA, comprise a series number, dimension series code, bore diameter number, and suffix. Bearing numbers of series NK bearings comprise a series number, dimension code (inscribed enveloping circle diameter/width dimension)



3. Internal clearance and bearing fits

The radial clearances of **NIKO** Machined Ring Roller Bearings with an inner ring are given in "Bearing Internal Clearance," Because the range of non-interchangeable clearance is limited, a bearing delivered adjusted to a non-interchangeable clearance must be mounted as is.

The dimensional tolerances (fits) with the shaft and housing bore when installing a bearing with an inner ring vary with the type and magnitude of load, shaft diameter, and housing bore size, and must satisfy the requirements in "Recommended fits," The required form accuracy and surface roughness are specified in "Shaft and housing accuracy," The bearing without an inner ring uses a shaft as a raceway surface. The required tolerances of the shaft diameter (raceway diameter) corresponding with the running clearance are given in Table 1 below. The dimensional tolerance of the housing bore is K7, which is commonly used. For the form accuracy, roughness, and hardness of the shaft as a raceway surface, refer to Table 1 "Accuracy of Raceway surface".

Table 1 Dimensional tolerances of shaft (raceway diameter)

Enveloping circle dia. <i>F_w</i> mm		Tolerance class of shaft		
		smaller than normal clearance	normal clearance	greater than normal clearance
over	incl.			
-	80	k5	h5	f6
80	160	k5	g5	f6
160	180	k5	g5	e6
180	200	j5	g5	e6
200	250	j5	f6	e6
250	315	h5	f6	e6
315	400	g5	f6	d6

MACHINED-RING NEEDLE ROLLER BEARINGS WITH INNER RING
SERIES NA 49-59-69

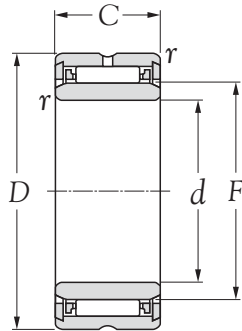

Type 49 ($d \leq 9\text{mm}$)

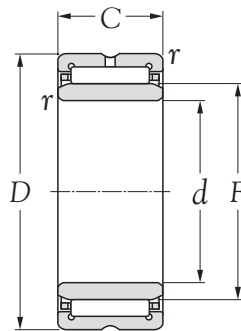

Type NA 49 ($d \geq 10\text{mm}$)
Type NA 59
Type NA 69 ($d \leq 30\text{mm}$)

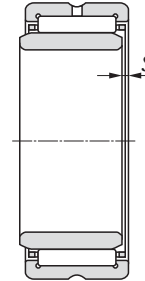

Boundary dimensions						Limiting speeds		Bearing numbers
mm						rpm		
d	D	C	r s min ¹⁾	F	s ²⁾	grease	oil	
5	13	10	0.15	7	-	23,000	34,000	NA 495
6	15	10	0.15	8	-	21,000	32,000	NA 496
7	17	10	0.15	9	-	20,000	30,000	NA 497
8	19	11	0.15	10	-	19,000	28,000	NA 498
9	20	11	0.30	12	-	17,000	26,000	NA 499
10	22	13	0.30	14	0.5	16,000	24,000	NA 4900
12	24	13	0.30	16	0.5	15,000	23,000	NA 4901
12	24	22	0.30	16	1.0	15,000	23,000	NA 6901
15	28	13	0.30	20	0.5	13,000	20,000	NA 4902
15	28	18	0.30	20	0.5	13,000	20,000	NA 5902
15	28	23	0.30	20	1.0	13,000	20,000	NA 6902
17	30	13	0.30	22	0.5	12,000	18,000	NA 4903
17	30	18	0.30	22	0.5	12,000	18,000	NA 5903
17	30	23	0.30	22	1.0	12,000	18,000	NA 6903
20	37	17	0.30	25	0.8	11,000	16,000	NA 4904
20	37	23	0.30	25	0.8	11,000	16,000	NA 5904
20	37	30	0.30	25	1.0	11,000	16,000	NA 6904
22	39	17	0.30	28	0.8	9,500	14,000	NA 49/22
22	39	23	0.30	28	0.8	9,500	14,000	NA 59/22
22	39	30	0.30	28	0.5	9,500	14,000	NA 69/22
25	42	17	0.30	30	0.8	8,500	13,000	NA 4905
25	42	23	0.30	30	0.8	8,500	13,000	NA 5905
25	42	30	0.30	30	1.0	8,500	13,000	NA 6905
28	45	17	0.30	32	0.8	8,500	13,000	NA 49/28
28	45	23	0.30	32	0.8	8,500	13,000	NA 59/28
28	45	30	0.30	32	1.0	8,500	13,000	NA 69/28
30	47	17	0.30	35	0.8	7,500	11,000	NA 4906
30	47	23	0.30	35	0.8	7,500	11,000	NA 5906

Notes: 1) These values are the allowable minimum dimensions of the chamfer dimension r .
 2) These values are the possible axial displacement of the inner ring against outer ring.

MACHINED-RING NEEDLE ROLLER BEARINGS WITH INNER RING
SERIES NA 49-59-69

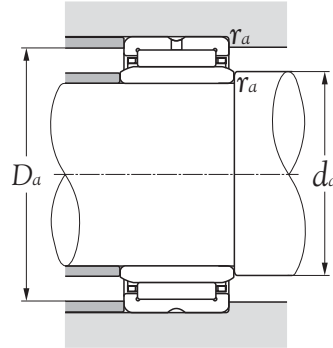
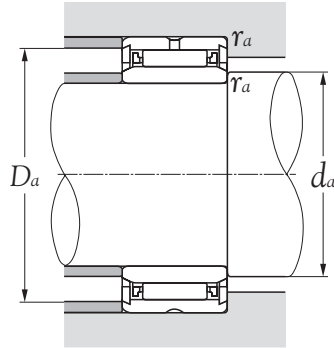

dynamic N	Basic load ratings		Abutment dimensions			Bearing numbers	Mass kg (approx.)	
	static	dynamic kgf	d_a min	D_a max	r_{as} max			
C_r	C_{or}	C_r	C_r	C_{or}				
2,670	2,350	272	239	6.2	8.5	0.15	NA 495	0.007
3,150	3,000	320	305	8.0	9.5	0.15	NA 496	0.009
3,600	3,650	365	375	9.0	10.5	0.15	NA 497	0.010
4,300	3,950	435	405	10.0	12.0	0.15	NA 498	0.016
4,850	4,900	495	500	11.0	14.0	0.30	NA 499	0.017
8,600	9,200	875	935	12.0	20.0	0.30	NA 4900	0.024
9,550	10,900	975	1,110	14.0	22.0	0.30	NA 4901	0.026
15,400	20,000	1,570	2,040	14.0	22.0	0.30	NA 6901	0.046
10,300	12,800	1,050	1,310	17.0	26.0	0.30	NA 4902	0.036
14,100	19,100	1,440	1,950	17.0	26.0	0.30	NA 5902	0.052
17,600	25,300	1,790	2,580	17.0	26.0	0.30	NA 6902	0.064
11,200	14,600	1,140	1,490	19.0	28.0	0.30	NA 4903	0.056
15,200	21,700	1,550	2,210	19.0	28.0	0.30	NA 5903	0.037
18,200	27,200	1,850	2,770	19.0	28.0	0.30	NA 6903	0.069
21,300	25,500	2,170	2,600	22.0	35.0	0.30	NA 4904	0.074
28,400	37,000	2,900	3,750	22.0	35.0	0.30	NA 5904	0.115
36,500	50,500	3,700	5,150	22.0	35.0	0.30	NA 6904	0.141
23,200	29,300	2,360	2,990	24.0	37.0	0.30	NA 49/22	0.080
26,400	37,500	2,690	3,850	24.0	37.0	0.30	NA 59/22	0.134
40,000	58,500	4,050	6,000	24.0	37.0	0.30	NA 69/22	0.154
24,000	31,500	2,450	3,200	27.0	40.0	0.30	NA 4905	0.088
30,500	43,000	3,150	4,350	27.0	40.0	0.30	NA 5905	0.139
41,500	63,000	4,200	6,400	27.0	40.0	0.30	NA 6905	0.162
24,800	33,500	2,530	3,400	30.0	43.0	0.30	NA 49/28	0.098
32,000	45,500	3,250	4,650	30.0	43.0	0.30	NA 59/28	0.142
43,000	67,000	4,350	6,850	30.0	43.0	0.30	NA 69/28	0.179
25,500	35,500	2,600	3,600	32.0	45.0	0.30	NA 4906	0.101
32,500	48,500	3,350	4,950	32.0	45.0	0.30	NA 5906	0.152

MACHINED-RING NEEDLE ROLLER BEARINGS WITH INNER RING
SERIES NA 49-59-69

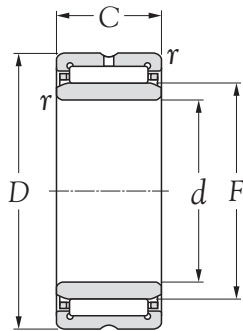

Type NA 49 ($d \geq 10\text{mm}$)
Type NA 59
Type NA 69 ($d \leq 30\text{mm}$)

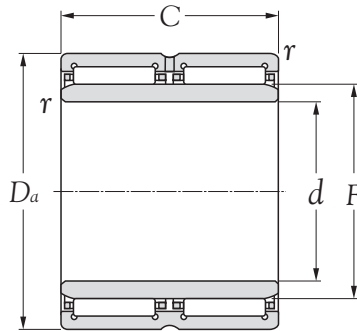

Type NA 69 ($d \geq 32\text{mm}$)

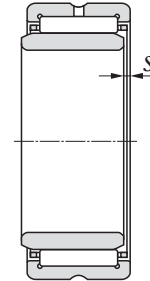

Boundary dimensions						Limiting speeds		Bearing numbers
mm						rpm		
d	D	C	$r_s \text{ min}^{1)}$	F	$s^{2)}$	grease	oil	
30	47	30	0.3	35	1.0	7,500	11,000	NA 6906
32	52	20	0.6	40	0.8	6,500	10,000	NA 49/32
32	52	27	0.6	40	0.8	6,500	10,000	NA 59/32
32	52	36	0.6	40	0.5	6,500	10,000	NA 69/32
35	55	20	0.6	42	0.8	6,500	9,500	NA 4907
35	55	27	0.6	42	0.8	6,500	9,500	NA 5907
35	55	36	0.6	42	0.5	6,500	9,500	NA 6907
40	62	22	0.6	48	1.0	5,500	8,500	NA 4908
40	62	30	0.6	48	1.0	5,500	8,500	NA 5908
40	62	40	0.6	48	0.5	5,500	8,500	NA 6908
45	68	22	0.6	52	1.0	5,000	7,500	NA 4909
45	68	30	0.6	52	1.0	5,000	7,500	NA 5909
45	68	40	0.6	52	0.5	5,000	7,500	NA 6909
50	72	22	0.6	58	1.0	4,700	7,000	NA 4910
50	72	30	0.6	58	1.0	4,700	7,000	NA 5910
50	72	40	0.6	58	0.5	4,700	7,000	NA 6910
55	80	25	1.0	63	1.5	4,300	6,500	NA 4911
55	80	34	1.0	63	1.5	4,300	6,500	NA 5911
55	80	45	1.0	63	1.5	4,300	6,500	NA 6911
60	85	25	1.0	68	1.5	4,000	6,000	NA 4912
60	85	34	1.0	68	1.5	4,000	6,000	NA 5912
60	85	45	1.0	68	1.5	4,000	6,000	NA 6912
65	90	25	1.0	72	1.5	3,700	5,500	NA 4913
65	90	34	1.0	72	1.5	3,700	5,500	NA 5913
65	90	45	1.0	72	1.5	3,700	5,500	NA 6913
70	100	30	1.0	80	1.5	3,300	5,000	NA 4914
70	100	40	1.0	80	1.5	3,300	5,000	NA 5914
70	100	54	1.0	80	1.0	3,300	5,000	NA 6914

Notes: 1) These values are the allowable minimum dimensions of the chamfer dimension r .
 2) These values are the possible axial displacement of the inner ring against outer ring.

MACHINED-RING NEEDLE ROLLER BEARINGS WITH INNER RING
SERIES NA 49-59-69

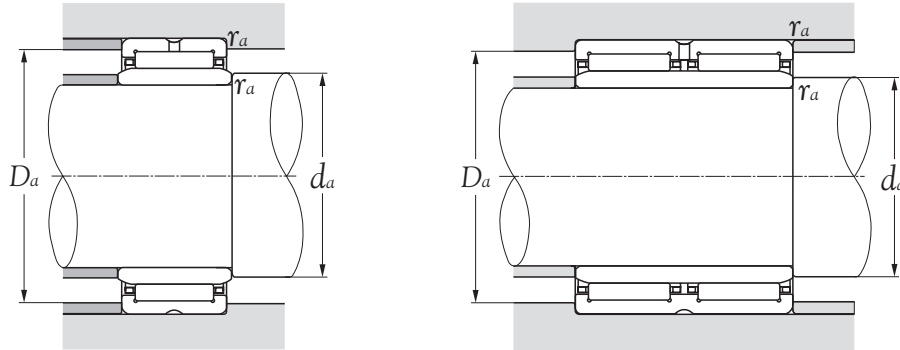

dynamic N	Basic load ratings		Abutment dimensions			Bearing numbers	Mass kg (approx.)	
	static	dynamic kgf	static	d_a min	D_a max			r_{as} max
C_r	C_{or}	C_r	C_{or}					
42,500	67,500	4,300	6,900	32.0	45.0	0.3	NA 6906	0.185
31,500	47,500	3,200	4,850	36.0	48.0	0.6	NA 49/32	0.157
38,000	61,000	3,850	6,250	36.0	48.0	0.6	NA 59/32	0.241
47,500	82,000	4,850	4,350	36.0	48.0	0.6	NA 69/32	0.286
32,000	50,000	3,300	5,100	39.0	51.0	0.6	NA 4907	0.171
39,000	64,500	3,950	6,550	39.0	51.0	0.6	NA 5907	0.256
49,000	86,500	5,000	8,800	39.0	51.0	0.6	NA 6907	0.310
43,500	66,500	4,450	6,800	44.0	58.0	0.6	NA 4908	0.232
53,000	92,500	5,450	9,450	44.0	58.0	0.6	NA 5908	0.348
67,000	116,000	6,850	11,800	44.0	58.0	0.6	NA 6908	0.426
46,000	73,000	4,700	7,450	49.0	64.0	0.6	NA 4909	0.270
56,000	101,000	5,700	10,300	49.0	64.0	0.6	NA 5909	0.396
70,500	127,000	7,200	13,000	49.0	64.0	0.6	NA 6909	0.437
48,000	80,000	4,900	8,150	54.0	68.0	0.6	NA 4910	0.276
58,000	110,000	5,950	11,200	54.0	68.0	0.6	NA 5910	0.498
74,000	139,000	7,500	14,200	54.0	68.0	0.6	NA 6910	0.529
58,500	99,500	6,000	10,100	60.0	75.0	1.0	NA 4911	0.396
76,500	140,000	7,800	14,300	60.0	75.0	1.0	NA 5911	0.559
94,000	183,000	9,600	18,600	60.0	75.0	1.0	NA 6911	0.726
61,500	108,000	6,250	11,000	65.0	80.0	1.0	NA 4912	0.427
80,500	153,000	8,200	15,600	65.0	80.0	1.0	NA 5912	0.614
95,500	191,000	9,750	19,400	65.0	80.0	1.0	NA 6912	0.758
62,500	112,000	6,350	11,400	70.0	85.0	1.0	NA 4913	0.454
84,000	165,000	8,600	16,800	70.0	85.0	1.0	NA 5913	0.655
97,000	198,000	9,900	20,200	70.0	85.0	1.0	NA 6913	0.779
85,500	156,000	8,750	15,900	75.0	95.0	1.0	NA 4914	0.727
103,000	187,000	10,500	19,100	75.0	95.0	1.0	NA 5914	1.060
130,000	267,000	13,300	27,200	75.0	95.0	1.0	NA 6914	1.340

MACHINED-RING NEEDLE ROLLER BEARINGS WITH INNER RING
SERIES NA 48-49-59-69

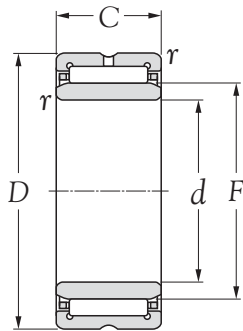

Type NA 48
 Type NA 49 ($d \geq 10\text{mm}$)
 Type NA 59

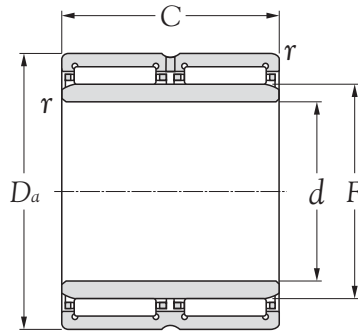

Type NA 69 ($d \geq 32\text{mm}$)

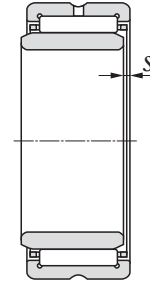

Boundary dimensions						Limiting speeds		Bearing numbers
mm						rpm		
d	D	C	$r_s \text{ min}^{1)}$	F	$s^{2)}$	grease	oil	
75	105	30	1.0	85	1.5	3,100	4,700	NA 4915
75	105	40	1.0	85	1.5	3,100	4,700	NA 5915
75	105	54	1.0	85	1.0	3,100	4,700	NA 6915
80	110	30	1.0	90	1.5	2,900	4,400	NA 4916
80	110	40	1.0	90	1.5	2,900	4,400	NA 5916
80	110	54	1.0	90	1.5	2,900	4,400	NA 6916
85	120	35	1.1	100	1.0	2,700	4,000	NA 4917
85	120	46	1.1	100	1.5	2,700	4,000	NA 5917
85	120	63	1.1	100	1.0	2,700	4,000	NA 6917
90	125	35	1.1	105	1.0	2,500	3,800	NA 4918
90	125	46	1.1	105	1.0	2,500	3,800	NA 5918
90	125	63	1.1	105	1.0	2,500	3,800	NA 6918
95	130	35	1.1	110	1.0	2,400	3,600	NA 4919
95	130	46	1.1	110	1.0	2,400	3,600	NA 5919
95	130	63	1.1	110	1.0	2,400	3,600	NA 6919
100	140	40	1.1	115	2.0	2,300	3,500	NA 4920
100	140	54	1.1	115	2.0	2,300	3,500	NA 5920
110	140	30	1.0	120	0.8	2,200	3,300	NA 4822
110	150	40	1.1	125	2.0	2,100	3,200	NA 4922
110	150	54	1.1	125	2.0	2,100	3,200	NA 5922
120	150	30	1.0	130	0.8	2,100	3,100	NA 4824
120	165	45	1.1	135	2.0	2,000	3,000	NA 4924
120	165	60	1.1	135	2.0	2,000	3,000	NA 5924
130	165	35	1.1	145	1.0	1,900	2,800	NA 4826
130	180	50	1.5	150	1.5	1,800	2,700	NA 4926
130	180	67	1.5	150	1.5	1,800	2,700	NA 5926
140	175	35	1.1	155	1.0	1,700	2,600	NA 4828
140	190	50	1.5	160	1.5	1,700	2,500	NA 4928

Notes: 1) These values are the allowable minimum dimensions of the chamfer dimension r .
 2) These values are the possible axial displacement of the inner ring against outer ring.

MACHINED-RING NEEDLE ROLLER BEARINGS WITH INNER RING
SERIES NA 48-49-59-69

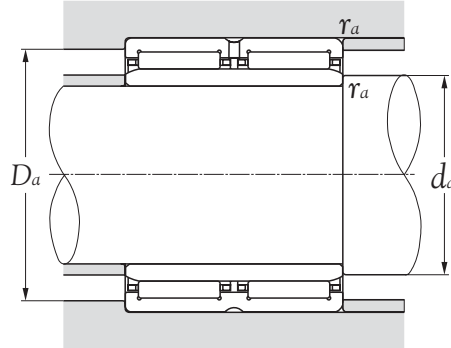
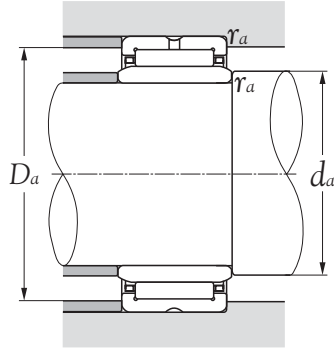

dynamic N	Basic load ratings		Abutment dimensions			Bearing numbers	Mass kg (approx.)
	static	dynamic kgf	d_a min	D_a max	r_{as} max		
C_r	C_{or}	C_r	C_{or}				
87,000	162,000	8,900	16,500	80.0	100.0	1.0	NA 4915 0.776
109,000	205,000	11,100	20,900	80.0	100.0	1.0	NA 5915 1.130
132,000	277,000	13,500	28,300	80.0	100.0	1.0	NA 6915 1.450
90,500	174,000	9,250	17,700	85.0	105.0	1.0	NA 4916 0.820
115,000	223,000	11,700	22,700	85.0	105.0	1.0	NA 5916 1.150
137,000	298,000	14,000	30,500	85.0	105.0	1.0	NA 6916 1.530
112,000	237,000	11,500	24,200	91.5	113.5	1.0	NA 4917 1.240
137,000	290,000	14,000	29,600	91.5	113.5	1.0	NA 5917 1.760
169,000	400,000	17,300	41,000	91.5	113.5	1.0	NA 6917 2.250
116,000	252,000	11,900	25,700	96.5	118.5	1.0	NA 4918 1.310
143,000	310,000	14,600	32,000	96.5	118.5	1.0	NA 5918 1.840
175,000	425,000	17,900	43,500	96.5	118.5	1.0	NA 6918 2.440
118,000	260,000	12,000	26,500	101.5	123.5	1.0	NA 4919 1.360
149,000	335,000	15,200	34,000	101.5	123.5	1.0	NA 5919 1.980
177,000	440,000	18,100	45,000	101.5	123.5	1.0	NA 6919 2.630
127,000	260,000	12,900	26,500	106.5	133.5	1.0	NA 4920 1.930
182,000	395,000	18,600	40,500	106.5	133.5	1.0	NA 5920 2.850
93,500	210,000	9,550	21,400	115.0	135.0	1.0	NA 4822 1.110
131,000	279,000	13,300	28,400	116.5	143.5	1.0	NA 4922 2.080
193,000	440,000	19,700	45,000	116.5	143.5	1.0	NA 5922 2.980
99,500	233,000	10,100	23,800	125.0	145.0	1.0	NA 4824 1.170
180,000	380,000	18,300	38,500	126.5	158.5	1.0	NA 4924 2.840
245,000	525,000	25,000	53,500	126.5	158.5	1.0	NA 5924 3.920
118,000	305,000	12,100	31,000	136.5	158.5	1.0	NA 4826 1.600
202,000	455,000	20,600	46,500	138.0	172.0	1.5	NA 4926 3.900
294,000	685,000	30,000	70,000	138.0	172.0	1.5	NA 5926 5.600
121,000	315,000	12,300	32,500	146.5	168.5	1.0	NA 4828 1.820
209,000	485,000	21,300	49,500	148.0	182.0	1.5	NA 4928 4.050

MACHINED-RING NEEDLE ROLLER BEARINGS WITH INNER RING
SERIES NA 48-49-59



Type NA 48
 Type NA 49..R ($d \geq 10\text{mm}$)
 Type NA 59

Boundary dimensions						Limiting speeds		Bearing numbers
mm						rpm		
d	D	C	$r_s \text{ min}^{1)}$	F	$s^{2)}$	grease	oil	
140	190	67	1.5	160	1.5	1,700	2,500	NA 5928
150	190	40	1.1	165	1.5	1,600	2,400	NA 4830
150	210	60	2.0	170	1.5	1,600	2,400	NA 4930
160	200	40	1.1	175	1.5	1,500	2,300	NA 4832
160	220	60	2.0	180	1.5	1,500	2,200	NA 4932
170	215	45	1.1	185	1.5	1,500	2,200	NA 4834
170	230	60	2.0	190	1.5	1,400	2,100	NA 4934
180	225	45	1.1	195	1.5	1,400	2,100	NA 4836
180	250	69	2.0	205	1.5	1,300	2,000	NA 4936
190	240	50	1.5	210	1.5	1,300	1,900	NA 4838
190	260	69	2.0	215	1.5	1,300	1,900	NA 4938
200	250	50	1.5	220	1.5	1,200	1,800	NA 4840
200	280	80	2.1	225	1.5	1,200	1,800	NA 4940
220	270	50	1.5	240	1.5	1,100	1,700	NA 4844
220	300	80	2.1	245	1.5	1,100	1,600	NA 4944
240	300	60	2.0	265	2.0	1,000	1,500	NA 4848
240	320	80	2.1	265	2.0	1,000	1,500	NA 4948
260	320	60	2.0	285	2.0	950	1,400	NA 4852
260	360	100	2.1	290	2.0	950	1,400	NA 4952
280	350	69	2.0	305	2.5	850	1,300	NA 4856
280	380	100	2.1	310	2.5	850	1,300	NA 4956
300	380	80	2.1	330	2.0	800	1,200	NA 4860
300	420	118	3.0	340	2.0	800	1,200	NA 4960
320	400	80	2.1	350	2.0	750	1,100	NA 4864
320	440	118	3.0	360	2.0	750	1,100	NA 4964
340	420	80	2.1	370	2.0	750	1,100	NA 4868
340	460	118	3.0	380	2.0	750	1,100	NA 4968
360	440	80	2.1	390	2.0	650	1,000	NA 4872

Notes: 1) These values are the allowable minimum dimensions of the chamfer dimension r .
 2) These values are the possible axial displacement of the inner ring against outer ring.

MACHINED-RING NEEDLE ROLLER BEARINGS WITH INNER RING
SERIES NA 48-49-59

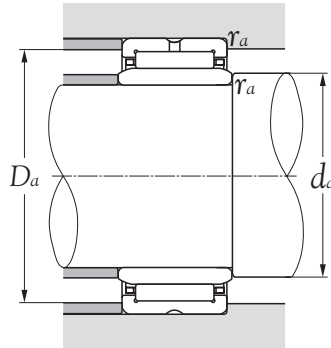

dynamic N	Basic load ratings		static kgf	Abutment dimensions			Bearing numbers	Mass kg (approx.)
	static C_{or}	dynamic C_r		d_a min	D_a max	r_{as} max		
310,000	755,000	31,500	77,000	148.0	182.0	1.5	NA 5928	6.180
152,000	390,000	15,500	40,000	156.5	183.5	1.0	NA 4830	2.720
261,000	610,000	26,600	62,500	159.0	201.0	2.0	NA 4930	5.330
160,000	425,000	16,300	43,500	166.5	193.5	1.0	NA 4832	2.900
270,000	650,000	27,600	66,500	169.0	211.0	2.0	NA 4932	5.600
185,000	495,000	18,800	50,500	176.5	208.5	1.0	NA 4834	3.990
279,000	690,000	28,500	70,500	179.0	221.0	2.0	NA 4934	5.870
195,000	540,000	19,800	55,000	186.5	218.5	1.0	NA 4836	4.190
375,000	890,000	38,500	90,500	189.0	241.0	2.0	NA 4936	8.580
227,000	680,000	23,200	69,000	198.0	232.0	1.5	NA 4838	5.620
390,000	945,000	40,000	96,500	199.0	251.0	2.0	NA 4938	8.680
231,000	705,000	23,600	71,500	208.0	242.0	1.5	NA 4840	5.840
505,000	1,180,000	51,500	120,000	211.0	269.0	2.0	NA 4940	12.200
244,000	780,000	24,900	79,500	228.0	262.0	1.5	NA 4844	6.370
525,000	1,270,000	53,500	129,000	231.0	289.0	2.0	NA 4944	13.500
360,000	1,080,000	37,000	110,000	249.0	291.0	2.0	NA 4848	10.000
540,000	1,350,000	55,000	138,000	251.0	309.0	2.0	NA 4948	14.700
375,000	1,160,000	38,000	119,000	269.0	311.0	2.0	NA 4852	10.800
805,000	1,900,000	82,000	193,000	271.0	349.0	2.0	NA 4952	25.900
455,000	1,300,000	46,500	133,000	289.0	341.0	2.0	NA 4856	15.500
835,000	2,030,000	85,000	207,000	291.0	369.0	2.0	NA 4956	27.500
625,000	1,770,000	64,000	180,000	311.0	369.0	2.0	NA 4860	22.000
1,080,000	2,640,000	110,000	269,000	313.0	407.0	2.5	NA 4960	42.500
640,000	1,850,000	65,500	189,000	331.0	389.0	2.0	NA 4864	23.200
1,120,000	2,820,000	114,000	288,000	333.0	427.0	2.5	NA 4964	45.200
655,000	1,940,000	66,500	197,000	351.0	409.0	2.0	NA 4868	24.100
1,160,000	3,000,000	118,000	305,000	353.0	447.0	2.5	NA 4968	47.300
665,000	2,020,000	68,000	206,000	371.0	429.0	2.0	NA 4872	25.700

MACHINED-RING NEEDLE ROLLER BEARINGS WITH INNER RING
SERIES NA 48-49

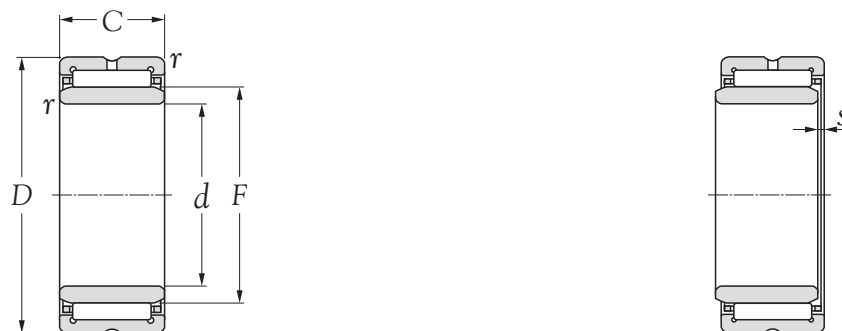

Boundary dimensions						Limiting speeds		Bearing numbers
mm						rpm		
<i>d</i>	<i>D</i>	<i>C</i>	<i>r</i> s min ¹⁾	<i>F</i>	<i>s</i> ²⁾	grease	oil	
360	480	118	3.0	400	2.0	650	1,000	NA 4972
380	480	100	2.1	415	2.0	650	950	NA 4876
380	520	140	4.0	430	2.0	650	950	NA 4976
400	540	140	4.0	450	2.5	600	900	NA 4980
420	560	140	4.0	470	2.5	550	850	NA 4984
440	600	160	4.0	490	2.5	550	800	NA 4988

Notes: 1) These values are the allowable minimum dimensions of the chamfer dimension *r*.
 2) These values are the possible axial displacement of the inner ring against outer ring.

MACHINED-RING NEEDLE ROLLER BEARINGS WITH INNER RING
SERIES NA 48-49

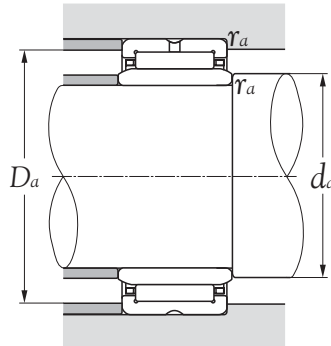

dynamic N	Basic load ratings		Abutment dimensions			Bearing numbers	Mass kg (approx.)
	static	dynamic kgf	d_a min	D_a max	r_{as} max		
C_r	C_{or}	C_r	C_{or}				
1,200,000	3,200,000	122,000	325,000	373	467	2.5	NA 4972 49.0
1,000,000	2,840,000	102,000	289,000	391	469	2.0	NA 4876 44.5
1,400,000	3,750,000	143,000	385,000	396	504	3.0	NA 4976 73.6
1,450,000	4,000,000	148,000	410,000	416	524	3.0	NA 4980 76.6
1,500,000	4,250,000	153,000	430,000	436	544	3.0	NA 4984 89.8
1,750,000	4,600,000	179,000	470,000	456	584	3.0	NA 4988 123.0

MACHINED-RING NEEDLE ROLLER BEARINGS WITH INNER RING SEALED TYPE
SERIES NA 49..L, LL

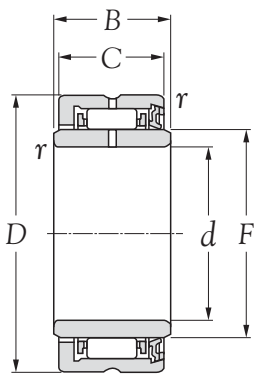

Type NA 49..L
(With single seal)

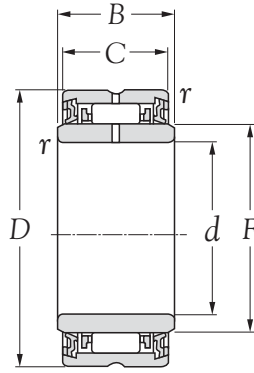

Type NA 49..LL
(With double seal)

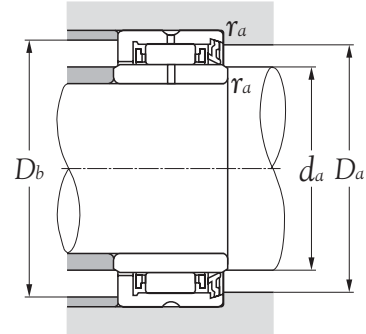

Boundary dimensions							Basic load ratings				Limiting speeds rpm	Abutment dimensions				Bearing numbers		Mass kg (approx.)
mm							dynamic	static	dynamic	static		d_a	D_a	D_b	r_{as}			
d	D	B	C	F	r_s	min ¹⁾	C_r	C_{or}	C_r	C_{or}		max	max	max	max			
10	22	14	13	14	0.3		7,200	8,500	735	865	10,000	12	16	20	0.3	NA 4900 L	NA 4900 LL	0.025
12	24	14	13	16	0.3		7,750	9,700	795	990	10,000	14	18	22	0.3	NA 4901 L	NA 4901 LL	0.028
15	28	14	13	20	0.3		8,300	11,200	845	1,150	10,000	17	22	26	0.3	NA 4902 L	NA 4902 LL	0.036
17	30	14	13	22	0.3		8,500	11,900	865	1,220	9,000	19	24	28	0.3	NA 4903 L	NA 4903 LL	0.039
20	37	18	17	25	0.3		15,200	19,900	1,550	2,030	8,000	22	28	35	0.3	NA 4904 L	NA 4904 LL	0.080
25	42	18	17	30	0.3		16,000	22,600	1,640	2,300	6,500	27	33	40	0.3	NA 4905 L	NA 4905 LL	0.093
30	47	18	17	35	0.3		18,000	27,400	1,830	2,800	5,500	32	38	45	0.3	NA 4906 L	NA 4906 LL	0.107
35	55	21	20	42	0.6		22,700	39,500	2,320	4,000	4,800	39	45	51	0.6	NA 4907 L	NA 4907 LL	0.175
40	62	23	22	48	0.6		27,800	53,500	2,830	5,450	4,200	44	51	58	0.6	NA 4908 L	NA 4908 LL	0.252
45	68	23	22	52	0.6		28,600	57,000	2,920	5,800	3,800	49	55	64	0.6	NA 4909 L	NA 4909 LL	0.290
50	72	23	22	58	0.6		30,500	64,000	3,100	6,500	3,400	54	61	68	0.6	NA 4910 L	NA 4910 LL	0.295

Notes: 1) These values are the allowable minimum dimensions of the chamfer dimension r .

MACHINED-RING NEEDLE ROLLER BEARINGS WITHOUT INNER RING SEALED TYPE
SERIES RNA 49..L, LL

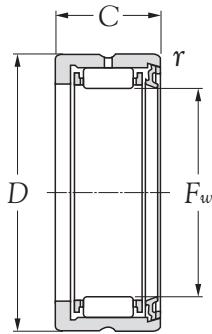

Type RNA 49..L
(With single seal)

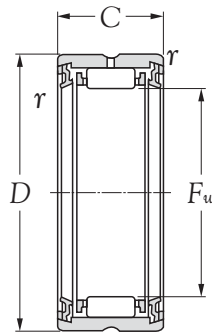

Type RNA 49..LL
(With double seal)

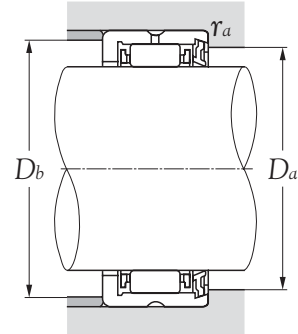

Boundary dimensions				Basic load ratings				Limiting speeds rpm	Abutment dimensions			Bearing numbers		Mass kg (approx.)	
mm				dynamic	static	dynamic	static		Da	Db	ras				
Fw	D	C	rs min ¹⁾	Cr	Cor	Cr	Cor	max	max	max					
14	^{+0.027} / _{+0.016}	22	13	0.3	7,200	8,500	735	865	10,000	16	20	0.3	RNA 4900 L	RNA 4900 LL	0.016
16	^{+0.027} / _{+0.016}	24	13	0.3	7,750	9,700	795	990	10,000	18	22	0.3	RNA 4901 L	RNA 4901 LL	0.018
20	^{+0.033} / _{+0.020}	28	13	0.3	8,300	11,200	845	1,150	10,000	22	26	0.3	RNA 4902 L	RNA 4902 LL	0.022
22	^{+0.033} / _{+0.020}	30	13	0.3	8,500	11,900	865	1,220	9,000	24	28	0.3	RNA 4903 L	RNA 4903 LL	0.022
25	^{+0.033} / _{+0.020}	37	17	0.3	15,200	19,900	1,550	2,030	8,000	28	35	0.3	RNA 4904 L	RNA 4904 LL	0.055
30	^{+0.033} / _{+0.020}	42	17	0.3	16,000	22,600	1,640	2,300	6,500	33	40	0.3	RNA 4905 L	RNA 4905 LL	0.063
35	^{+0.041} / _{+0.025}	47	17	0.3	18,000	27,400	1,830	2,800	5,500	38	45	0.3	RNA 4906 L	RNA 4906 LL	0.072
42	^{+0.041} / _{+0.025}	55	20	0.6	22,700	39,500	2,320	4,000	4,800	45	51	0.6	RNA 4907 L	RNA 4907 LL	0.113
48	^{+0.041} / _{+0.025}	62	22	0.6	27,800	53,500	2,830	5,450	4,200	51	58	0.6	RNA 4908 L	RNA 4908 LL	0.154
52	^{+0.049} / _{+0.030}	68	22	0.6	28,600	57,000	2,920	5,800	3,800	55	64	0.6	RNA 4909 L	RNA 4909 LL	0.157
58	^{+0.049} / _{+0.030}	72	22	0.6	30,500	64,000	3,100	6,500	3,400	61	68	0.6	RNA 4910 L	RNA 4910 LL	0.160

Notes: 1) These values are the allowable minimum dimensions of the chamfer dimension r.

MACHINED-RING NEEDLE ROLLER BEARINGS WITHOUT INNER RING
SERIES RNA 49-59-69

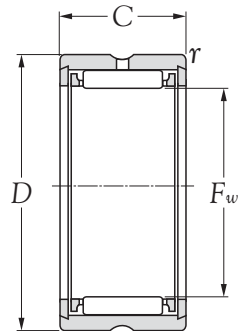

Type RNA 49 ($F_w \leq 12\text{mm}$)

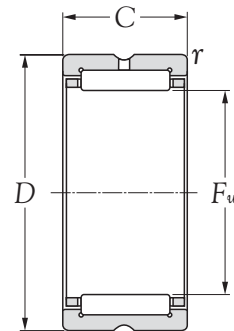

Type RNA 49 ($F_w \geq 14\text{mm}$)
Type RNA 59
Type RNA 69 ($F_w \leq 35\text{mm}$)

F_w	Boundary dimensions			$r_s \text{ min}^1$	Limiting speeds		Bearing numbers
	D	C	r		grease	oil	
7 ^{+0.022} / _{+0.013}	13	10	0.15	23,000	34,000	RNA 495	
8 ^{+0.022} / _{+0.013}	15	10	0.15	21,000	32,000	RNA 496	
9 ^{+0.022} / _{+0.013}	17	10	0.15	20,000	30,000	RNA 497	
10 ^{+0.022} / _{+0.013}	19	11	0.15	19,000	28,000	RNA 498	
12 ^{+0.027} / _{+0.016}	20	11	0.30	17,000	26,000	RNA 499	
14 ^{+0.027} / _{+0.016}	22	13	0.30	16,000	24,000	RNA 4900	
16 ^{+0.027} / _{+0.016}	24	13	0.30	15,000	23,000	RNA 4901	
16 ^{+0.027} / _{+0.016}	24	22	0.30	15,000	23,000	RNA 6901	
20 ^{+0.033} / _{+0.020}	28	13	0.30	13,000	20,000	RNA 4902	
20 ^{+0.033} / _{+0.020}	28	18	0.30	13,000	20,000	RNA 5902	
20 ^{+0.033} / _{+0.020}	28	23	0.30	13,000	20,000	RNA 6902	
22 ^{+0.033} / _{+0.020}	30	13	0.30	12,000	18,000	RNA 4903	
22 ^{+0.033} / _{+0.020}	30	18	0.30	12,000	18,000	RNA 5903	
22 ^{+0.033} / _{+0.020}	30	23	0.30	12,000	18,000	RNA 6903	
25 ^{+0.033} / _{+0.020}	37	17	0.30	11,000	16,000	RNA 4904	
25 ^{+0.033} / _{+0.020}	37	23	0.30	11,000	16,000	RNA 5904	
25 ^{+0.033} / _{+0.020}	37	30	0.30	11,000	16,000	RNA 6904	
28 ^{+0.033} / _{+0.020}	39	17	0.30	9,500	14,000	RNA 49/22	
28 ^{+0.033} / _{+0.020}	39	23	0.30	9,500	14,000	RNA 59/22	
28 ^{+0.033} / _{+0.020}	39	30	0.30	9,500	14,000	RNA 69/22	
30 ^{+0.033} / _{+0.020}	42	17	0.30	8,500	13,000	RNA 4905	
30 ^{+0.033} / _{+0.020}	42	23	0.30	8,500	13,000	RNA 5905	
30 ^{+0.033} / _{+0.020}	42	30	0.30	8,500	13,000	RNA 6905	
32 ^{+0.041} / _{+0.025}	45	17	0.30	8,500	13,000	RNA 49/28	
32 ^{+0.041} / _{+0.025}	45	23	0.30	8,500	13,000	RNA 59/28	
32 ^{+0.041} / _{+0.025}	45	30	0.30	8,500	13,000	RNA 69/28	
35 ^{+0.041} / _{+0.025}	47	17	0.30	7,500	11,000	RNA 4906	
35 ^{+0.041} / _{+0.025}	47	23	0.30	7,500	11,000	RNA 5906	

Notes: 1) These values are the allowable minimum dimensions of the chamfer dimension r .

MACHINED-RING NEEDLE ROLLER BEARINGS WITHOUT INNER RING
SERIES RNA 49-59-69

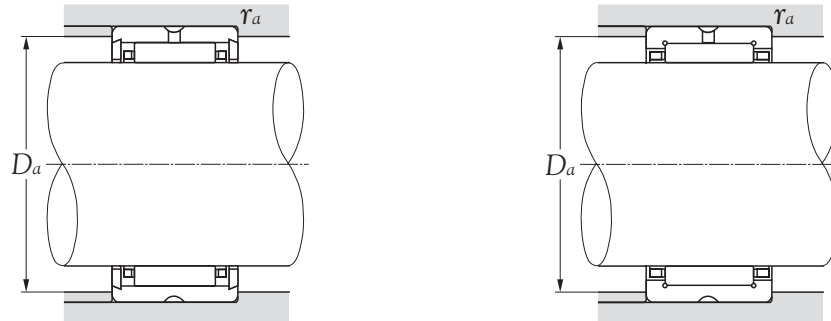

dynamic N	Basic load ratings		Abutment dimensions		Bearing numbers	Mass kg (approx.)	
	static	dynamic kgf	D_a max	r_{as} max			
C_r	C_{or}	C_r	C_{or}				
2,670	2,350	272	239	8.5	0.15	RNA 495	0.0055
3,150	3,000	320	305	9.5	0.15	RNA 496	0.0073
3,600	3,650	365	375	10.5	0.15	RNA 497	0.0095
4,300	3,950	435	405	12.0	0.15	RNA 498	0.0130
4,850	4,900	495	500	14.0	0.30	RNA 499	0.0130
8,600	9,200	875	935	20.0	0.30	RNA 4900	0.0170
9,550	10,900	975	1,110	22.0	0.30	RNA 4901	0.0170
15,400	20,000	1,570	2,040	22.0	0.30	RNA 6901	0.0310
10,300	12,800	1,050	1,310	26.0	0.30	RNA 4902	0.0220
14,100	19,100	1,440	1,950	26.0	0.30	RNA 5902	0.0330
17,600	25,300	1,790	2,580	26.0	0.30	RNA 6902	0.0400
11,200	14,600	1,140	1,490	28.0	0.30	RNA 4903	0.0220
15,200	21,700	1,550	2,210	28.0	0.30	RNA 5903	0.0350
18,200	27,200	1,850	2,770	28.0	0.30	RNA 6903	0.0420
21,300	25,500	2,170	2,600	35.0	0.30	RNA 4904	0.0520
28,400	37,000	2,900	3,750	35.0	0.30	RNA 5904	0.0840
36,500	50,500	3,700	5,150	35.0	0.30	RNA 6904	0.1000
23,200	29,300	2,360	2,990	37.0	0.30	RNA 49/22	0.0500
26,400	37,500	2,690	3,850	37.0	0.30	RNA 59/22	0.0920
40,000	58,500	4,050	6,000	37.0	0.30	RNA 69/22	0.1000
24,000	31,500	2,450	3,200	40.0	0.30	RNA 4905	0.0610
30,500	43,000	3,150	4,350	40.0	0.30	RNA 5905	0.1010
41,500	63,000	4,200	6,400	40.0	0.30	RNA 6905	0.1120
24,800	33,500	2,530	3,400	43.0	0.30	RNA 49/28	0.0730
32,000	45,500	3,250	4,650	43.0	0.30	RNA 59/28	0.1080
43,000	67,000	4,350	6,850	43.0	0.30	RNA 69/28	0.1350
25,500	35,500	2,600	3,600	45.0	0.30	RNA 4906	0.0690
32,500	48,500	3,350	4,950	45.0	0.30	RNA 5906	0.1080

MACHINED-RING NEEDLE ROLLER BEARINGS WITHOUT INNER RING
SERIES RNA 49-59-69

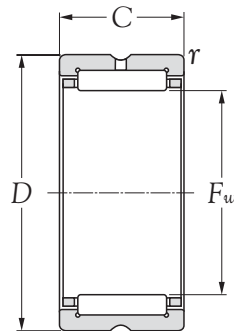

Type RNA 49 ($F_w \geq 14\text{mm}$)
 Type RNA 59
 Type RNA 69 ($F_w \leq 35\text{mm}$)

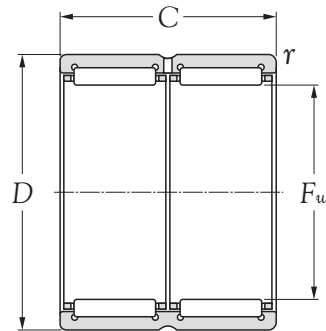

Type RNA 69 ($F_w \geq 40\text{mm}$)

F_w	Boundary dimensions			$r_s \text{ min}^{1)}$	Limiting speeds		Bearing numbers
	mm				rpm		
	D	C		grease	oil		
35 ^{+0.041} / _{+0.025}	47	30	0.3	7,500	11,000	RNA 6906	
40 ^{+0.041} / _{+0.025}	52	20	0.6	6,500	10,000	RNA 49/32	
40 ^{+0.041} / _{+0.025}	52	27	0.6	6,500	10,000	RNA 59/32	
40 ^{+0.041} / _{+0.025}	52	36	0.6	6,500	10,000	RNA 69/32	
42 ^{+0.041} / _{+0.025}	55	20	0.6	6,500	9,500	RNA 4907	
42 ^{+0.041} / _{+0.025}	55	27	0.6	6,500	9,500	RNA 5907	
42 ^{+0.041} / _{+0.025}	55	36	0.6	6,500	9,500	RNA 6907	
48 ^{+0.041} / _{+0.025}	62	22	0.6	5,500	8,500	RNA 4908	
48 ^{+0.041} / _{+0.025}	62	30	0.6	5,500	8,500	RNA 5908	
48 ^{+0.041} / _{+0.025}	62	40	0.6	5,500	8,500	RNA 6908	
52 ^{+0.049} / _{+0.030}	68	22	0.6	5,000	7,500	RNA 4909	
52 ^{+0.049} / _{+0.030}	68	30	0.6	5,000	7,500	RNA 5909	
52 ^{+0.049} / _{+0.030}	68	40	0.6	5,000	7,500	RNA 6909	
58 ^{+0.049} / _{+0.030}	72	22	0.6	4,700	7,000	RNA 4910	
58 ^{+0.049} / _{+0.030}	72	30	0.6	4,700	7,000	RNA 5910	
58 ^{+0.049} / _{+0.030}	72	40	0.6	4,700	7,000	RNA 6910	
63 ^{+0.049} / _{+0.030}	80	25	1.0	4,300	6,500	RNA 4911	
63 ^{+0.049} / _{+0.030}	80	34	1.0	4,300	6,500	RNA 5911	
63 ^{+0.049} / _{+0.030}	80	45	1.0	4,300	6,500	RNA 6911	
68 ^{+0.049} / _{+0.030}	85	25	1.0	4,000	6,000	RNA 4912	
68 ^{+0.049} / _{+0.030}	85	34	1.0	4,000	6,000	RNA 5912	
68 ^{+0.049} / _{+0.030}	85	45	1.0	4,000	6,000	RNA 6912	
72 ^{+0.049} / _{+0.030}	90	25	1.0	3,700	5,500	RNA 4913	
72 ^{+0.049} / _{+0.030}	90	34	1.0	3,700	5,500	RNA 5913	
72 ^{+0.049} / _{+0.030}	90	45	1.0	3,700	5,500	RNA 6913	
80 ^{+0.049} / _{+0.030}	100	30	1.0	3,300	5,000	RNA 4914	
80 ^{+0.049} / _{+0.030}	100	40	1.0	3,300	5,000	RNA 5914	
80 ^{+0.049} / _{+0.030}	100	54	1.0	3,300	5,000	RNA 6914	

Notes: 1) These values are the allowable minimum dimensions of the chamfer dimension r.

MACHINED-RING NEEDLE ROLLER BEARINGS WITHOUT INNER RING
SERIES RNA 49-59-69

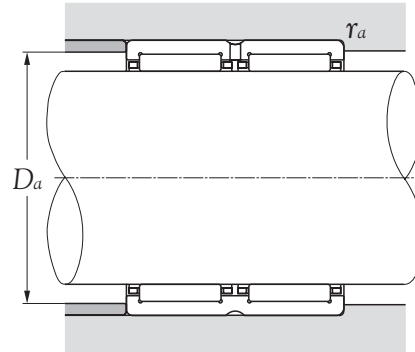
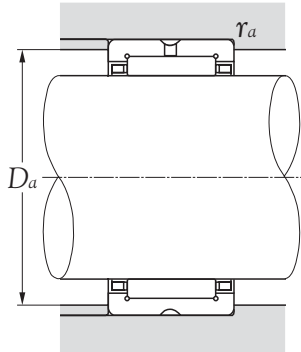

dynamic N	Basic load ratings		Abutment dimensions		Bearing numbers	Mass kg (approx.)	
	static	dynamic kgf	D_a max	r_{as} max			
C_r	C_{or}	C_r	C_{or}				
42,500	67,500	4,300	6,900	45	0.3	RNA 6906	0.126
31,500	47,500	3,200	4,850	48	0.6	RNA 49/32	0.089
38,000	61,000	3,850	6,250	48	0.6	RNA 59/32	0.149
47,500	82,000	4,850	8,350	48	0.6	RNA 69/32	0.162
32,000	50,000	3,300	5,100	51	0.6	RNA 4907	0.107
39,000	64,500	3,950	6,550	51	0.6	RNA 5907	0.176
49,000	86,500	5,000	8,800	51	0.6	RNA 6907	0.193
43,500	66,500	4,450	6,800	58	0.6	RNA 4908	0.140
53,000	92,500	5,450	9,450	58	0.6	RNA 5908	0.225
67,000	116,000	6,850	11,800	58	0.6	RNA 6908	0.256
46,000	73,000	4,700	7,450	64	0.6	RNA 4909	0.182
56,000	101,000	5,700	10,300	64	0.6	RNA 5909	0.232
70,500	127,000	7,200	13,000	64	0.6	RNA 6909	0.273
48,000	80,000	4,900	8,150	68	0.6	RNA 4910	0.163
58,000	110,000	5,950	11,200	68	0.6	RNA 5910	0.289
74,000	139,000	7,500	14,200	68	0.6	RNA 6910	0.320
58,500	99,500	6,000	10,100	75	1.0	RNA 4911	0.255
76,500	140,000	7,800	14,300	75	1.0	RNA 5911	0.367
94,000	183,000	9,600	18,600	75	1.0	RNA 6911	0.470
61,500	108,000	6,250	11,000	80	1.0	RNA 4912	0.275
80,500	153,000	8,200	15,600	80	1.0	RNA 5912	0.408
95,500	191,000	9,750	19,400	80	1.0	RNA 6912	0.488
62,500	112,000	6,350	11,400	85	1.0	RNA 4913	0.312
84,000	165,000	8,600	16,800	85	1.0	RNA 5913	0.462
97,000	198,000	9,900	20,200	85	1.0	RNA 6913	0.520
85,500	156,000	8,750	15,900	95	1.0	RNA 4914	0.460
103,000	187,000	10,500	19,100	95	1.0	RNA 5914	0.706
130,000	267,000	13,300	27,200	95	1.0	RNA 6914	0.857

MACHINED-RING NEEDLE ROLLER BEARINGS WITHOUT INNER RING
SERIES RNA 48-49-59-69

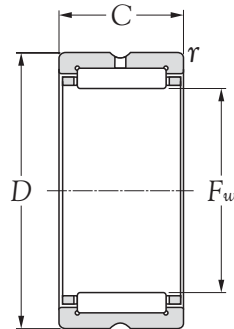

Type RNA 48
 Type RNA 49 ($F_w \geq 14\text{mm}$)
 Type RNA 59

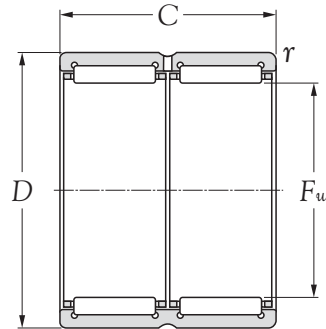

Type RNA 69 ($F_w \geq 40\text{mm}$)

Boundary dimensions				Limiting speeds		Bearing numbers
F_w	mm			rpm		
	D	C	$r_s \text{ min}^{1)}$	grease	oil	
85 ^{+0.058} / _{+0.036}	105	30	1.0	3,100	4,700	RNA 4915
85 ^{+0.058} / _{+0.036}	105	40	1.0	3,100	4,700	RNA 5915
85 ^{+0.058} / _{+0.036}	105	54	1.0	3,100	4,700	RNA 6915
90 ^{+0.058} / _{+0.036}	110	30	1.0	2,900	4,400	RNA 4916
90 ^{+0.058} / _{+0.036}	110	40	1.0	2,900	4,400	RNA 5916
90 ^{+0.058} / _{+0.036}	110	54	1.0	2,900	4,400	RNA 6916
100 ^{+0.058} / _{+0.036}	120	35	1.1	2,700	4,000	RNA 4917
100 ^{+0.058} / _{+0.036}	120	46	1.1	2,700	4,000	RNA 5917
100 ^{+0.058} / _{+0.036}	120	63	1.1	2,700	4,000	RNA 6917
105 ^{+0.058} / _{+0.036}	125	35	1.1	2,500	3,800	RNA 4918
105 ^{+0.058} / _{+0.036}	125	46	1.1	2,500	3,800	RNA 5918
105 ^{+0.058} / _{+0.036}	125	63	1.1	2,500	3,800	RNA 6918
110 ^{+0.058} / _{+0.036}	130	35	1.1	2,400	3,600	RNA 4919
110 ^{+0.058} / _{+0.036}	130	46	1.1	2,400	3,600	RNA 5919
110 ^{+0.058} / _{+0.036}	130	63	1.1	2,400	3,600	RNA 6919
115 ^{+0.058} / _{+0.036}	140	40	1.1	2,300	3,500	RNA 4920
115 ^{+0.058} / _{+0.036}	140	54	1.1	2,300	3,500	RNA 5920
120 ^{+0.058} / _{+0.036}	140	30	1.0	2,200	3,300	RNA 4822
125 ^{+0.068} / _{+0.043}	150	40	1.1	2,100	3,200	RNA 4922
125 ^{+0.068} / _{+0.043}	150	54	1.1	2,100	3,200	RNA 5922
130 ^{+0.068} / _{+0.043}	150	30	1.0	2,100	3,100	RNA 4824
135 ^{+0.068} / _{+0.043}	165	45	1.1	2,000	3,000	RNA 4924
135 ^{+0.068} / _{+0.043}	165	60	1.1	2,000	3,000	RNA 5924
145 ^{+0.068} / _{+0.043}	165	35	1.1	1,900	2,800	RNA 4826
150 ^{+0.068} / _{+0.043}	180	50	1.5	1,800	2,700	RNA 4926
150 ^{+0.068} / _{+0.043}	180	67	1.5	1,800	2,700	RNA 5926
155 ^{+0.068} / _{+0.043}	175	35	1.1	1,700	2,600	RNA 4828
160 ^{+0.068} / _{+0.043}	190	50	1.5	1,700	2,500	RNA 4928

Notes: 1) These values are the allowable minimum dimensions of the chamfer dimension r .

MACHINED-RING NEEDLE ROLLER BEARINGS WITHOUT INNER RING
SERIES RNA 48-49-59-69

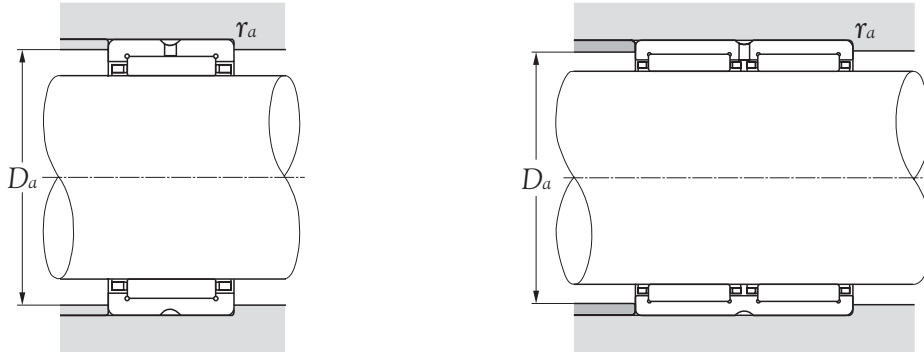

dynamic N	Basic load ratings		Abutment dimensions		Bearing numbers	Mass kg (approx.)	
	static	dynamic kgf	D_a max	r_{as} max			
C_r	C_{or}	C_r	C_{or}				
87,000	162,000	8,900	16,500	100.0	1.0	RNA 4915	0.489
109,000	205,000	11,100	20,900	100.0	1.0	RNA 5915	0.745
132,000	277,000	13,500	28,300	100.0	1.0	RNA 6915	0.935
90,500	174,000	9,250	17,700	105.0	1.0	RNA 4916	0.516
115,000	223,000	11,700	22,700	105.0	1.0	RNA 5916	0.787
137,000	298,000	14,000	30,500	105.0	1.0	RNA 6916	0.987
112,000	237,000	11,500	24,200	113.5	1.0	RNA 4917	0.657
137,000	290,000	14,000	29,600	113.5	1.0	RNA 5917	1.000
169,000	400,000	17,300	41,000	113.5	1.0	RNA 6917	1.200
116,000	252,000	11,900	25,700	118.5	1.0	RNA 4918	0.697
143,000	310,000	14,600	32,000	118.5	1.0	RNA 5918	1.040
175,000	425,000	17,900	43,500	118.5	1.0	RNA 6918	1.330
118,000	260,000	12,000	26,500	123.5	1.0	RNA 4919	0.719
149,000	335,000	15,200	34,000	123.5	1.0	RNA 5919	1.130
177,000	440,000	18,100	45,000	123.5	1.0	RNA 6919	1.460
127,000	260,000	12,900	26,500	133.5	1.0	RNA 4920	1.150
182,000	395,000	18,600	40,500	133.5	1.0	RNA 5920	1.760
93,500	210,000	9,550	21,400	135.0	1.0	RNA 4822	0.670
131,000	279,000	13,300	28,400	143.5	1.0	RNA 4922	1.240
193,000	440,000	19,700	45,000	143.5	1.0	RNA 5922	1.890
99,500	233,000	10,100	23,800	145.0	1.0	RNA 4824	0.730
180,000	380,000	18,300	38,500	158.5	1.0	RNA 4924	1.860
245,000	525,000	25,000	53,500	158.5	1.0	RNA 5924	2.670
118,000	305,000	12,100	31,000	158.5	1.0	RNA 4826	0.950
202,000	455,000	20,600	46,500	172.0	1.5	RNA 4926	2.210
294,000	685,000	30,000	70,000	172.0	1.5	RNA 5926	3.210
121,000	315,000	12,300	32,500	168.5	1.0	RNA 4828	1.020
209,000	485,000	21,300	49,500	182.0	1.5	RNA 4928	2.350

MACHINED-RING NEEDLE ROLLER BEARINGS WITHOUT INNER RING
SERIES RNA48-49-59

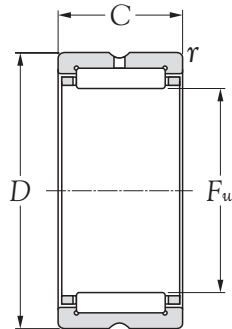

Type RNA 48
 Type RNA 49 ($F_w \geq 14\text{mm}$)
 Type RNA 59

Boundary dimensions				Limiting speeds		Bearing numbers
mm				rpm		
F_w	D	C	$r_s \text{ min}^{1)}$	grease	oil	
160 ^{+0.068} / _{+0.043}	190	67	1.5	1,700	2,500	RNA 5928
165 ^{+0.068} / _{+0.043}	190	40	1.1	1,600	2,400	RNA 4830
170 ^{+0.068} / _{+0.043}	210	60	2.0	1,600	2,400	RNA 4930
175 ^{+0.068} / _{+0.043}	200	40	1.1	1,500	2,300	RNA 4832
180 ^{+0.068} / _{+0.043}	220	60	2.0	1,500	2,200	RNA 4932
185 ^{+0.079} / _{+0.050}	215	45	1.1	1,500	2,200	RNA 4834
190 ^{+0.079} / _{+0.050}	230	60	2.0	1,400	2,100	RNA 4934
195 ^{+0.079} / _{+0.050}	225	45	1.1	1,400	2,100	RNA 4836
205 ^{+0.079} / _{+0.050}	250	69	2.0	1,300	2,000	RNA 4936
210 ^{+0.079} / _{+0.050}	240	50	1.5	1,300	1,900	RNA 4838
215 ^{+0.079} / _{+0.050}	260	69	2.0	1,300	1,900	RNA 4938
220 ^{+0.079} / _{+0.050}	250	50	1.5	1,200	1,800	RNA 4840
225 ^{+0.079} / _{+0.050}	280	80	2.1	1,200	1,800	RNA 4940
240 ^{+0.079} / _{+0.050}	270	50	1.5	1,100	1,700	RNA 4844
245 ^{+0.079} / _{+0.050}	300	80	2.1	1,100	1,600	RNA 4944
265 ^{+0.088} / _{+0.056}	300	60	2.0	1,000	1,500	RNA 4848
265 ^{+0.088} / _{+0.056}	320	80	2.1	1,000	1,500	RNA 4948
285 ^{+0.088} / _{+0.056}	320	60	2.0	950	1,400	RNA 4852
290 ^{+0.088} / _{+0.056}	360	100	2.1	950	1,400	RNA 4952
305 ^{+0.088} / _{+0.056}	350	69	2.0	850	1,300	RNA 4856
310 ^{+0.088} / _{+0.056}	380	100	2.1	850	1,300	RNA 4956
330 ^{+0.098} / _{+0.062}	380	80	2.1	800	1,200	RNA 4860
340 ^{+0.098} / _{+0.062}	420	118	3.0	800	1,200	RNA 4960
350 ^{+0.098} / _{+0.062}	400	80	2.1	750	1,100	RNA 4864
360 ^{+0.098} / _{+0.062}	440	118	3.0	750	1,100	RNA 4964
370 ^{+0.098} / _{+0.062}	420	80	2.1	750	1,100	RNA 4868
380 ^{+0.098} / _{+0.062}	460	118	3.0	750	1,100	RNA 4968
390 ^{+0.098} / _{+0.062}	440	80	2.1	650	1,000	RNA 4872

Notes: 1) These values are the allowable minimum dimensions of the chamfer dimension r .

MACHINED-RING NEEDLE ROLLER BEARINGS WITHOUT INNER RING
SERIES RNA48-49-59

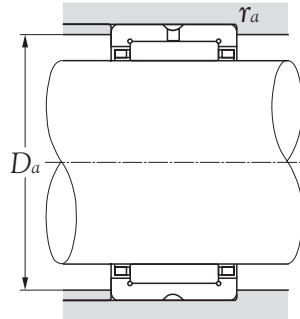

dynamic N	Basic load ratings		Abutment dimensions		Bearing numbers	Mass kg (approx.)	
	static	dynamic kgf	D_a max	r_{as} max			
C_r	C_{or}	C_r	C_{or}				
310,000	755,000	31,500	77,000	182.0	1.5	RNA 5928	3.480
152,000	390,000	15,500	40,000	183.5	1.0	RNA 4830	1.600
261,000	610,000	26,600	62,500	201.0	2.0	RNA 4930	2.980
160,000	425,000	16,300	43,500	193.5	1.0	RNA 4832	1.700
270,000	650,000	27,600	66,500	211.0	2.0	RNA 4932	3.100
185,000	495,000	18,800	50,500	208.5	1.0	RNA 4834	2.540
279,000	690,000	28,500	70,500	221.0	2.0	RNA 4934	3.220
195,000	540,000	19,800	55,000	218.5	1.0	RNA 4836	2.680
375,000	890,000	38,500	90,500	241.0	2.0	RNA 4936	4.480
227,000	680,000	23,200	69,000	232.0	1.5	RNA 4838	3.210
390,000	945,000	40,000	96,500	251.0	2.0	RNA 4938	4.530
231,000	705,000	23,600	71,500	242.0	1.5	RNA 4840	3.350
505,000	1,180,000	51,500	120,000	269.0	2.0	RNA 4940	7.200
242,000	770,000	24,700	78,500	262.0	1.5	RNA 4844	3.620
525,000	1,270,000	53,500	129,000	289.0	2.0	RNA 4944	7.810
360,000	1,080,000	37,000	110,000	291.0	2.0	RNA 4848	5.400
540,000	1,350,000	55,000	138,000	309.0	2.0	RNA 4948	8.400
375,000	1,160,000	38,000	119,000	311.0	2.0	RNA 4852	5.800
805,000	1,900,000	82,000	193,000	349.0	2.0	RNA 4952	15.900
455,000	1,300,000	46,500	133,000	341.0	2.0	RNA 4856	9.300
835,000	2,030,000	85,000	207,000	369.0	2.0	RNA 4956	16.700
625,000	1,770,000	64,000	180,000	369.0	2.0	RNA 4860	12.700
1,080,000	2,640,000	110,000	269,000	407.0	2.5	RNA 4960	24.000
640,000	1,850,000	65,500	189,000	389.0	2.0	RNA 4864	13.400
1,120,000	2,820,000	114,000	288,000	427.0	2.5	RNA 4964	25.200
665,000	1,940,000	66,500	197,000	409.0	2.0	RNA 4868	14.000
1,160,000	3,000,000	118,000	305,000	447.0	2.5	RNA 4968	26.500
665,000	2,020,000	68,000	206,000	429.0	2.0	RNA 4872	14.800

MACHINED-RING NEEDLE ROLLER BEARINGS WITHOUT INNER RING
SERIES RNA48-49

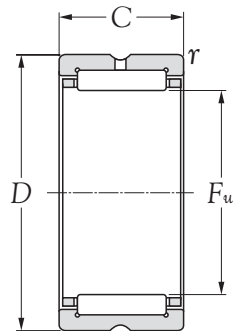

Type RNA 48
Type RNA 49 ($F_w \geq 14\text{mm}$)

Boundary dimensions				Limiting speeds		Bearing numbers
mm				rpm		
F_w	D	C	$r_s \text{ min}^1)$	grease	oil	
400 ^{+0.108} / _{+0.068}	480	118	3.0	650	1.000	RNA 4972
415 ^{+0.108} / _{+0.068}	480	100	2.1	650	950	RNA 4876
430 ^{+0.108} / _{+0.068}	520	140	4.0	650	950	RNA 4976
450 ^{+0.108} / _{+0.068}	540	140	4.0	600	900	RNA 4980
470 ^{+0.108} / _{+0.068}	560	140	4.0	550	850	RNA 4984
490 ^{+0.108} / _{+0.068}	600	160	4.0	550	800	RNA 4988

Notes: 1) These values are the allowable minimum dimensions of the chamfer dimension r .

MACHINED-RING NEEDLE ROLLER BEARINGS WITHOUT INNER RING
SERIES RNA48-49

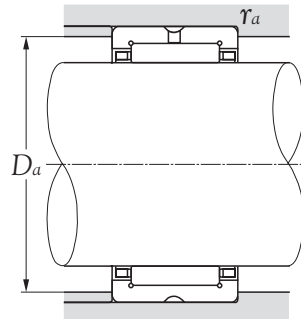

dynamic N	Basic load ratings		dynamic kgf	static	Abutment dimensions		Bearing numbers	Mass kg (approx.)
	static	dynamic			D_a max	r_{as} max		
C_r	C_{or}	C_r	C_{or}					
1,200,000	3,200,000	122,000	325,000	467	2.5	RNA 4972	28.200	
1,000,000	2,840,000	102,000	289,000	469	3.0	RNA 4876	26.000	
1,400,000	3,750,000	143,000	385,000	504	3.0	RNA 4976	38.600	
1,450,000	4,000,000	148,000	410,000	524	3.0	RNA 4980	40.100	
1,500,000	4,250,000	153,000	430,000	544	3.0	RNA 4984	51.600	
1,750,000	4,600,000	179,000	470,000	584	3.0	RNA 4988	66.900	

**MACHINED-RING NEEDLE ROLLER BEARINGS WITHOUT INNER RING
SERIES NK**

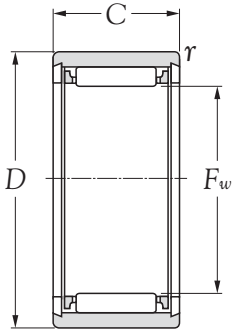

Type NK ($F_w \leq 12\text{mm}$)

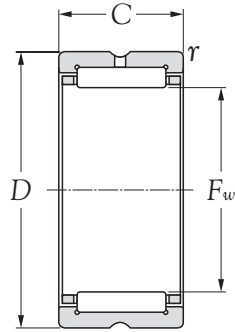

Type NK ($F_w \geq 14\text{mm}$)

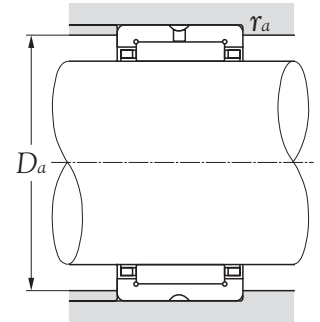
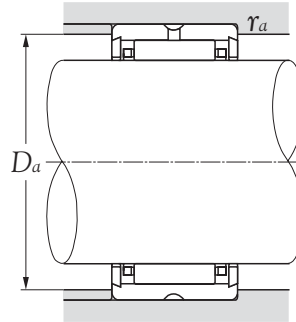

Boundary dimensions				Basic load ratings				Limiting speeds		Bearing numbers	Aboutment dimensions		Mass kg (approx.)
F_w	mm D	C	$r_s \text{ min}^{-1}$	dynamic N C_r	static C_{or}	dynamic kgf C_r	static C_{or}	rpm			D_a max	r_{as} max	
5 ^{+0.018} / _{+0.010}	10	10	0.15	2,640	2,190	269	224	27,000	40,000	NK 5/10	6.5	0.15	0.0031
5 ^{+0.018} / _{+0.010}	10	12	0.15	2,720	2,250	277	230	27,000	40,000	NK 5/12	6.5	0.15	0.0037
6 ^{+0.018} / _{+0.010}	12	10	0.15	2,660	2,280	272	233	25,000	37,000	NK 6/10	7.5	0.15	0.0047
6 ^{+0.018} / _{+0.010}	12	12	0.15	3,400	3,150	345	320	25,000	37,000	NK 6/12	7.5	0.15	0.0057
7 ^{+0.022} / _{+0.013}	14	10	0.30	2,670	2,350	272	239	23,000	34,000	NK 7/10	8.5	0.30	0.0069
7 ^{+0.022} / _{+0.013}	14	12	0.30	3,400	3,200	345	330	23,000	34,000	NK 7/12	8.5	0.30	0.0082
8 ^{+0.022} / _{+0.013}	15	12	0.30	4,000	4,100	410	420	21,000	32,000	NK 8/12	9.5	0.30	0.0087
8 ^{+0.022} / _{+0.013}	15	16	0.30	4,850	5,200	495	535	21,000	32,000	NK 8/16	9.5	0.30	0.0120
9 ^{+0.022} / _{+0.013}	16	12	0.30	4,550	5,000	465	510	20,000	30,000	NK 9/12	10.5	0.30	0.0100
9 ^{+0.022} / _{+0.013}	16	16	0.30	5,500	6,400	560	650	20,000	30,000	NK 9/16	10.5	0.30	0.0130
10 ^{+0.022} / _{+0.013}	17	12	0.30	4,550	5,100	460	520	19,000	28,000	NK 10/12	11.5	0.30	0.0100
10 ^{+0.022} / _{+0.013}	17	16	0.30	5,450	6,450	555	660	19,000	28,000	NK 10/16	11.5	0.30	0.0130
12 ^{+0.027} / _{+0.016}	19	12	0.30	5,000	6,100	510	620	17,000	26,000	NK 12/12	13.5	0.30	0.0130
12 ^{+0.027} / _{+0.016}	19	16	0.30	6,000	7,700	615	785	17,000	26,000	NK 12/16	13.5	0.30	0.0160
14 ^{+0.027} / _{+0.016}	22	16	0.30	10,300	11,500	1,050	1,170	16,000	24,000	NK 14/16	20.0	0.30	0.0210
14 ^{+0.027} / _{+0.016}	22	20	0.30	13,000	15,600	1,330	1,590	16,000	24,000	NK 14/20	20.0	0.30	0.0260
15 ^{+0.027} / _{+0.016}	23	16	0.30	10,900	12,700	1,110	1,290	15,000	23,000	NK 15/16	21.0	0.30	0.0220
15 ^{+0.027} / _{+0.016}	23	20	0.30	13,800	17,200	1,410	1,750	15,000	23,000	NK 15/20	21.0	0.30	0.0270
16 ^{+0.027} / _{+0.016}	24	16	0.30	12,200	14,900	1,240	1,520	15,000	23,000	NK 16/16	22.0	0.30	0.0220
16 ^{+0.027} / _{+0.016}	24	20	0.30	14,600	18,800	1,490	1,920	15,000	23,000	NK 16/20	22.0	0.30	0.0280
17 ^{+0.027} / _{+0.016}	25	16	0.30	12,100	15,000	1,240	1,530	15,000	22,000	NK 17/16	23.0	0.30	0.0240
17 ^{+0.027} / _{+0.016}	25	20	0.30	15,400	20,400	1,570	2,080	15,000	22,000	NK 17/20	23.0	0.30	0.0300
18 ^{+0.027} / _{+0.016}	26	16	0.30	12,700	16,200	1,300	1,650	14,000	21,000	NK 18/16	24.0	0.30	0.0250
18 ^{+0.027} / _{+0.016}	26	20	0.30	16,100	22,000	1,640	2,250	14,000	21,000	NK 18/20	24.0	0.30	0.0310
19 ^{+0.033} / _{+0.020}	27	16	0.30	13,300	17,400	1,350	1,780	14,000	21,000	NK 19/16	25.0	0.30	0.0260
19 ^{+0.033} / _{+0.020}	27	20	0.30	16,000	22,200	1,630	2,260	14,000	21,000	NK 19/20	25.0	0.30	0.0320
20 ^{+0.033} / _{+0.020}	28	16	0.30	13,200	17,500	1,340	1,790	13,000	20,000	NK 20/16	26.0	0.30	0.0270
20 ^{+0.033} / _{+0.020}	28	20	0.30	16,700	23,800	1,700	2,420	13,000	20,000	NK 20/20	26.0	0.30	0.0340

Notes: 1) These values are the allowable minimum dimensions of the chamfer dimension r .

**MACHINED-RING NEEDLE ROLLER BEARINGS WITHOUT INNER RING
SERIES NK**

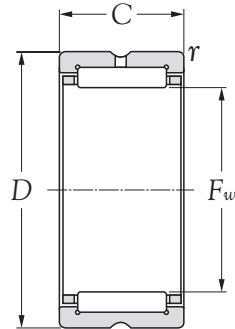

Type NK (Fw ≥ 14mm)

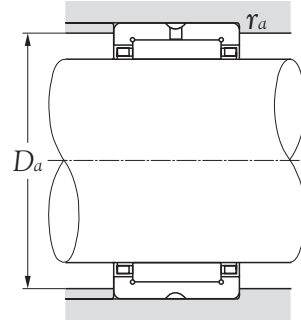

Boundary dimensions				Basic load ratings				Limiting speeds		Bearing numbers	Aboutment dimensions		Mass kg (approx.)
F _w	mm		r _s min ¹⁾	dynamic N	static	dynamic kgf	static	rpm			D _a max	r _{as} max	
	D	C		C _r	C _{or}	C _r	C _{or}	grease	oil				
21 ^{+0.033} / _{+0.020}	29	16	0.3	13,700	18,700	1,400	1,910	13,000	19,000	NK 21/16	27	0.3	0.028
21 ^{+0.033} / _{+0.020}	29	20	0.3	18,300	27,100	1,860	2,760	13,000	19,000	NK 21/20	27	0.3	0.035
22 ^{+0.033} / _{+0.020}	30	16	0.3	14,200	19,900	1,450	2,030	12,000	18,000	NK 22/16	28	0.3	0.034
22 ^{+0.033} / _{+0.020}	30	20	0.3	18,000	27,000	1,840	2,760	12,000	18,000	NK 22/20	28	0.3	0.037
24 ^{+0.033} / _{+0.020}	32	16	0.3	15,200	22,300	1,550	2,280	11,000	17,000	NK 24/16	30	0.3	0.032
24 ^{+0.033} / _{+0.020}	32	20	0.3	18,600	28,800	1,890	2,930	11,000	17,000	NK 24/20	30	0.3	0.040
25 ^{+0.033} / _{+0.020}	33	16	0.3	15,100	22,400	1,540	2,280	11,000	16,000	NK 25/16	31	0.3	0.033
25 ^{+0.033} / _{+0.020}	33	20	0.3	19,200	30,500	1,960	3,100	11,000	16,000	NK 25/20	31	0.3	0.042
26 ^{+0.033} / _{+0.020}	34	16	0.3	15,600	23,600	1,590	2,410	10,000	15,000	NK 26/16	32	0.3	0.034
26 ^{+0.033} / _{+0.020}	34	20	0.3	19,100	30,500	1,940	3,100	10,000	15,000	NK 26/20	32	0.3	0.042
28 ^{+0.033} / _{+0.020}	37	20	0.3	22,300	34,000	2,280	3,450	9,500	14,000	NK 28/20	35	0.3	0.052
28 ^{+0.033} / _{+0.020}	37	30	0.3	26,700	48,000	2,720	4,900	9,500	14,000	NK 28/30	35	0.3	0.082
29 ^{+0.033} / _{+0.020}	38	20	0.3	22,200	34,000	2,270	3,450	9,500	14,000	NK 29/20	36	0.3	0.054
29 ^{+0.033} / _{+0.020}	38	30	0.3	27,500	50,500	2,810	5,150	9,500	14,000	NK 29/30	36	0.3	0.084
30 ^{+0.033} / _{+0.020}	40	20	0.3	22,100	34,000	2,260	3,500	8,500	13,000	NK 30/20	38	0.3	0.065
30 ^{+0.033} / _{+0.020}	40	30	0.3	33,000	57,000	3,350	5,800	8,500	13,000	NK 30/30	38	0.3	0.098
32 ^{+0.041} / _{+0.025}	42	20	0.3	23,500	37,500	2,400	3,850	8,500	13,000	NK 32/20	40	0.3	0.068
32 ^{+0.041} / _{+0.025}	42	30	0.3	34,000	60,500	3,450	6,150	8,500	13,000	NK 32/30	40	0.3	0.102
35 ^{+0.041} / _{+0.025}	45	20	0.3	24,800	41,500	2,520	4,250	7,500	11,000	NK 35/20	43	0.3	0.074
35 ^{+0.041} / _{+0.025}	45	30	0.3	36,000	66,500	3,650	6,800	7,500	11,000	NK 35/30	43	0.3	0.112
37 ^{+0.041} / _{+0.025}	47	20	0.3	25,300	43,500	2,580	4,400	7,500	11,000	NK 37/20	45	0.3	0.077
37 ^{+0.041} / _{+0.025}	47	30	0.3	36,500	69,500	3,750	7,100	7,500	11,000	NK 37/30	45	0.3	0.107
38 ^{+0.041} / _{+0.025}	48	20	0.3	25,900	45,000	2,640	4,600	7,500	11,000	NK 38/20	46	0.3	0.079
38 ^{+0.041} / _{+0.025}	48	30	0.3	37,500	73,000	3,850	7,400	7,500	11,000	NK 38/30	46	0.3	0.107
40 ^{+0.041} / _{+0.025}	50	20	0.3	26,400	47,000	2,700	4,800	6,500	10,000	NK 40/20	48	0.3	0.083
40 ^{+0.041} / _{+0.025}	50	30	0.3	38,500	76,000	3,900	7,750	6,500	10,000	NK 40/30	48	0.3	0.125
42 ^{+0.041} / _{+0.025}	52	20	0.3	26,900	49,000	2,750	5,000	6,500	9,500	NK 42/20	50	0.3	0.086
42 ^{+0.041} / _{+0.025}	52	30	0.3	39,000	79,000	4,000	8,050	6,500	9,500	NK 42/30	50	0.3	0.130

Notes: 1) These values are the allowable minimum dimensions of the chamfer dimension r.

MACHINED-RING NEEDLE ROLLER BEARINGS WITHOUT INNER RING

SERIES NK

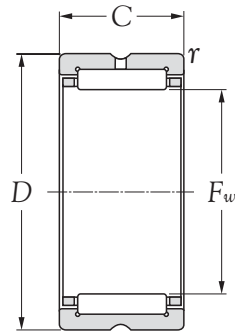

Type NK (Fw ≥ 14mm)

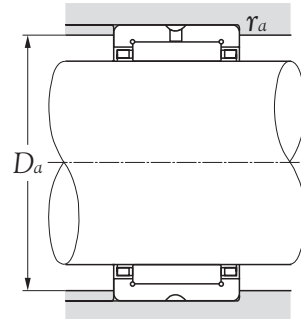

Boundary dimensions				Basic load ratings				Limiting speeds		Bearing numbers	Aboutment dimensions		Mass kg (approx.)
F _w	mm		r _s min ¹⁾	dynamic N	static	dynamic kgf	static	rpm			D _a max	r _{as} max	
	D	C		C _r	C _{or}	C _r	C _{or}	grease	oil				
43 ^{+0.041} _{+0.025}	53	20	0.3	27,500	51,000	2,810	5,200	6,500	9,500	NK 43/20	51	0.3	0.086
43 ^{+0.041} _{+0.025}	53	30	0.3	40,000	82,000	4,100	8,400	6,500	9,500	NK 43/30	51	0.3	0.133
45 ^{+0.041} _{+0.025}	55	20	0.3	28,000	52,500	2,860	5,400	6,000	9,000	NK 45/20	53	0.3	0.092
45 ^{+0.041} _{+0.025}	55	30	0.3	41,000	85,500	4,150	8,700	6,000	9,000	NK 45/30	53	0.3	0.139
47 ^{+0.041} _{+0.025}	57	20	0.3	28,800	55,500	2,940	5,650	5,500	8,500	NK 47/20	55	0.3	0.095
47 ^{+0.041} _{+0.025}	57	30	0.3	42,500	91,500	4,350	9,350	5,500	8,500	NK 47/30	55	0.3	0.142
50 ^{+0.041} _{+0.025}	62	25	0.6	38,500	74,500	3,950	7,550	5,500	8,000	NK 50/25	58	0.6	0.158
50 ^{+0.041} _{+0.025}	62	35	0.6	51,000	106,000	5,200	10,800	5,500	8,000	NK 50/35	58	0.6	0.221
55 ^{+0.049} _{+0.030}	68	25	0.6	41,000	82,000	4,150	8,400	5,000	7,500	NK 55/25	64	0.6	0.193
55 ^{+0.049} _{+0.030}	68	35	0.6	54,000	118,000	5,500	12,000	5,000	7,500	NK 55/35	64	0.6	0.267
60 ^{+0.049} _{+0.030}	72	25	0.6	41,000	85,000	4,200	8,700	4,300	6,500	NK 60/25	68	0.6	0.185
60 ^{+0.049} _{+0.030}	72	35	0.6	57,000	130,000	5,800	13,200	4,300	6,500	NK 60/35	68	0.6	0.258
65 ^{+0.049} _{+0.030}	78	25	0.6	45,000	98,000	4,550	10,000	4,000	6,000	NK 65/25	74	0.6	0.221
65 ^{+0.049} _{+0.030}	78	35	0.6	60,000	142,000	6,100	14,400	4,000	6,000	NK 65/35	74	0.6	0.310
68 ^{+0.049} _{+0.030}	82	25	1.0	44,500	89,000	4,500	9,050	4,000	6,000	NK 68/25	77	0.6	0.241
68 ^{+0.049} _{+0.030}	82	35	0.6	63,000	139,000	6,400	14,200	4,000	6,000	NK 68/35	78	0.6	0.338
70 ^{+0.049} _{+0.030}	85	25	0.6	45,000	91,500	4,600	9,350	3,700	5,500	NK 70/25	81	0.6	0.275
70 ^{+0.049} _{+0.030}	85	35	0.6	64,000	144,000	6,550	14,700	3,700	5,500	NK 70/35	81	0.6	0.386
73 ^{+0.049} _{+0.030}	90	25	0.6	54,000	100,000	5,500	10,200	3,700	5,500	NK 73/25	86	0.6	0.302
73 ^{+0.049} _{+0.030}	90	35	0.6	76,500	156,000	7,800	16,000	3,700	5,500	NK 73/35	86	0.6	0.428
75 ^{+0.049} _{+0.030}	92	25	0.6	55,000	104,000	5,600	10,600	3,700	5,500	NK 75/25	88	0.6	0.315
75 ^{+0.049} _{+0.030}	92	35	0.6	78,000	162,000	7,950	16,500	3,700	5,500	NK 75/35	88	0.6	0.492
80 ^{+0.049} _{+0.030}	95	25	1.0	57,000	119,000	5,800	12,200	3,300	5,000	NK 80/25	90	1.0	0.301
80 ^{+0.049} _{+0.030}	95	35	1.0	79,500	184,000	8,150	18,700	3,300	5,000	NK 80/35	90	1.0	0.425
85 ^{+0.058} _{+0.036}	105	25	1.0	70,500	123,000	7,200	12,600	3,100	4,700	NK 85/25	100	1.0	0.404
85 ^{+0.058} _{+0.036}	105	35	1.0	100,000	193,000	10,200	19,700	3,100	4,700	NK 85/35	100	1.0	0.517
90 ^{+0.058} _{+0.036}	110	25	1.0	71,500	128,000	7,300	13,100	2,900	4,400	NK 90/25	105	1.0	0.426
90 ^{+0.058} _{+0.036}	110	35	1.0	104,000	208,000	10,600	21,200	2,900	4,400	NK 90/35	105	1.0	0.604

Notes: 1) These values are the allowable minimum dimensions of the chamfer dimension r.

MACHINED-RING NEEDLE ROLLER BEARINGS WITHOUT INNER RING
SERIES NK

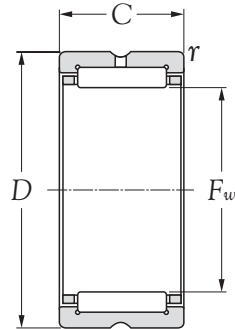

Type NK (Fw ≥ 14mm)

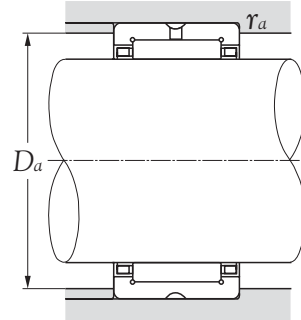

Boundary dimensions				Basic load ratings				Limiting speeds		Bearing numbers	Aboutment dimensions		Mass kg (approx.)
F _w	mm			dynamic	static	dynamic	static	rpm			D _a max	r _{as} max	
	D	C	r _s min ¹⁾	C _r	C _{or}	C _r	C _{or}	grease	oil				
95 ^{+0.058} / _{+0.036}	115	26	1.0	74,500	137,000	7,600	14,000	2,800	4,200	NK 95/26	110.0	1.0	0.364
95 ^{+0.058} / _{+0.036}	115	36	1.0	108,000	223,000	11,100	22,700	2,800	4,200	NK 95/36	110.0	1.0	0.652
100 ^{+0.058} / _{+0.036}	120	26	1.0	73,500	137,000	7,500	14,000	2,700	4,000	NK 100/26	115.0	1.0	0.487
100 ^{+0.058} / _{+0.036}	120	36	1.0	107,000	223,000	11,000	22,800	2,700	4,000	NK 100/36	115.0	1.0	0.679
105 ^{+0.058} / _{+0.036}	125	26	1.0	76,500	147,000	7,800	14,900	2,500	3,800	NK 105/26	120.0	1.0	0.506
105 ^{+0.058} / _{+0.036}	125	36	1.0	111,000	238,000	11,400	24,300	2,500	3,800	NK 105/36	120.0	1.0	0.713
110 ^{+0.058} / _{+0.036}	130	30	1.1	97,500	204,000	9,950	20,800	2,400	3,600	NK 110/30	123.5	1.0	0.612
110 ^{+0.058} / _{+0.036}	130	40	1.1	129,000	292,000	13,100	29,700	2,400	3,600	NK 110/40	123.5	1.0	0.830
120 ^{+0.058} / _{+0.036}	140	40	1.1	113,000	268,000	11,500	27,300	2,200	3,300	NK 120/40	133.5	1.0	0.910
130 ^{+0.068} / _{+0.043}	150	40	1.1	116,000	283,000	11,800	28,800	2,100	3,100	NK 130/40	143.5	1.0	0.980
145 ^{+0.068} / _{+0.043}	170	32	1.5	111,000	238,000	11,300	24,300	1,900	2,800	NK 145/32	162.5	1.5	1.120
145 ^{+0.068} / _{+0.043}	170	42	1.5	153,000	360,000	15,600	36,500	1,900	2,800	NK 145/42	162.5	1.5	1.490
155 ^{+0.068} / _{+0.043}	180	32	1.5	114,000	252,000	11,600	25,700	1,700	2,600	NK 155/32	172.0	1.5	1.200
155 ^{+0.068} / _{+0.043}	180	42	1.5	156,000	380,000	16,000	38,500	1,700	2,600	NK 155/42	172.0	1.5	1.590
165 ^{+0.068} / _{+0.043}	190	32	1.5	117,000	265,000	11,900	27,000	1,600	2,400	NK 165/32	182.0	1.5	1.420
165 ^{+0.068} / _{+0.043}	190	42	1.5	160,000	400,000	16,300	40,500	1,600	2,400	NK 165/42	182.0	1.5	1.660

Notes: 1) These values are the allowable minimum dimensions of the chamfer dimension r.

**MACHINED-RING NEEDLE ROLLER BEARINGS WITH INNER RING
SERIES NKI**

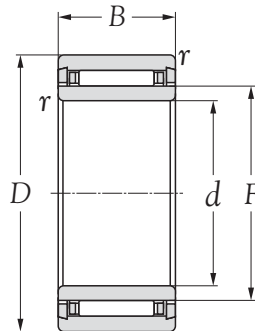

Boundary dimensions					Basic load ratings		Limiting speed	Bearing numbers	Mass
mm					dynamic	static			
<i>d</i>	<i>F</i>	<i>D</i>	<i>B</i>	<i>r</i> s min ¹⁾	N <i>C_r</i>	<i>C_{or}</i>	rpm oil		kg (approx.)
5	8	15	12	0.3	3,950	4,100	32,000	NKI 5/12 TN	0.012
5	8	15	16	0.3	5,100	5,800	32,000	NKI 5/16 TN	0.015
6	9	16	12	0.3	4,500	5,000	31,000	NKI 6/12 TN	0.014
6	9	16	16	0.3	5,900	7,100	31,000	NKI 6/16 TN	0.018
7	10	17	12	0.3	4,750	5,500	29,000	NKI 7/12 TN	0.014
7	10	17	16	0.3	6,200	7,800	29,000	NKI 7/16 TN	0.018
9	12	19	12	0.3	6,400	7,100	27,000	NKI 9/12	0.017
9	12	19	16	0.3	9,000	11,000	27,000	NKI 9/16	0.022
10	14	22	16	0.3	10,100	11,500	25,000	NKI 10/16	0.029
10	14	22	20	0.3	12,800	15,600	25,000	NKI 10/20	0.037
12	16	24	16	0.3	11,300	13,900	23,000	NKI 12/16	0.033
12	16	24	20	0.3	14,400	18,800	23,000	NKI 12/20	0.042
15	19	27	16	0.3	13,000	17,400	22,000	NKI 15/16	0.039
15	19	27	20	0.3	16,500	23,600	22,000	NKI 15/20	0.049
17	21	29	16	0.3	13,500	18,700	21,000	NKI 17/16	0.043
17	21	29	20	0.3	17,100	25,500	21,000	NKI 17/20	0.054
20	24	32	16	0.3	15,000	22,300	18,000	NKI 20/16	0.049
20	24	32	20	0.3	19,000	30,500	18,000	NKI 20/20	0.061
22	26	34	16	0.3	15,300	23,600	17,000	NKI 22/16	0.052
22	26	34	20	0.3	19,400	32,000	17,000	NKI 22/20	0.065
25	29	38	20	0.3	21,900	34,000	15,000	NKI 25/20	0.080
25	29	38	30	0.3	32,500	57,000	15,000	NKI 25/30	0.120
28	32	42	20	0.3	23,100	37,500	14,000	NKI 28/20	0.097
28	32	42	30	0.3	34,500	63,000	14,000	NKI 28/30	0.150
30	35	45	20	0.3	24,300	41,500	13,000	NKI 30/20	0.110
30	35	45	30	0.3	36,500	69,000	13,000	NKI 30/30	0.170
32	37	47	20	0.3	24,900	43,500	12,000	NKI 32/20	0.120
32	37	47	30	0.3	37,000	73,000	12,000	NKI 32/30	0.180

Notes: 1) These values are the allowable minimum dimensions of the chamfer dimension *r*.

**MACHINED-RING NEEDLE ROLLER BEARINGS WITH INNER RING
SERIES NKI**

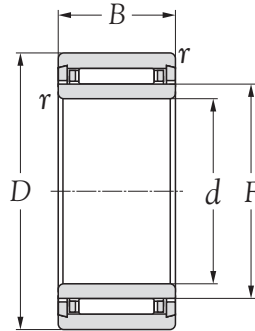

Boundary dimensions					Basic load ratings		Limiting speed	Bearing numbers	Mass
mm					dynamic	static			
<i>d</i>	<i>F</i>	<i>D</i>	<i>B</i>	<i>r</i> s min ¹⁾	N		rpm		kg
					<i>C_r</i>	<i>C_{or}</i>	oil		(approx.)
35	40	50	20	0.3	26,000	47,000	11,000	NKI 35/20	0.130
35	40	50	30	0.3	39,000	79,000	11,000	NKI 35/30	0.190
38	43	53	20	0.3	27,000	51,000	11,000	NKI 38/20	0.140
38	43	53	30	0.3	40,500	85,000	11,000	NKI 38/30	0.210
40	45	55	20	0.3	27,500	53,000	10,000	NKI 40/20	0.140
40	45	55	30	0.3	41,000	88,000	10,000	NKI 40/30	0.220
42	47	57	20	0.3	28,500	56,000	10,000	NKI 42/20	0.150
42	47	57	30	0.3	43,000	94,000	10,000	NKI 42/30	0.220
45	50	62	25	0.6	38,000	74,000	9,000	NKI 45/25	0.230
45	50	62	35	0.6	50,000	106,000	9,000	NKI 45/35	0.320
50	55	68	25	0.6	40,000	82,000	8,500	NKI 50/25	0.270
50	55	68	35	0.6	53,000	118,000	8,500	NKI 50/35	0.380
55	60	72	25	0.6	42,000	90,000	7,500	NKI 55/25	0.270
55	60	72	35	0.6	56,000	130,000	7,500	NKI 55/35	0.380
60	68	82	25	0.6	43,500	89,000	7,000	NKI 60/25	0.400
60	68	82	35	0.6	62,000	139,000	7,000	NKI 60/35	0.550
65	73	90	25	1.0	53,000	100,000	6,500	NKI 65/25	0.470
65	73	90	35	1.0	75,000	156,000	6,500	NKI 65/35	0.660
70	80	95	25	1.0	56,000	119,000	6,000	NKI 70/25	0.520
70	80	95	35	1.0	78,000	184,000	6,000	NKI 70/35	0.740
75	85	105	25	1.0	69,000	123,000	5,500	NKI 75/25	0.640
75	85	105	35	1.0	98,000	193,000	5,500	NKI 75/35	0.910
80	90	110	25	1.0	72,000	132,000	5,000	NKI 80/25	0.680
80	90	110	35	1.0	103,000	208,000	5,000	NKI 80/35	0.960
85	95	115	26	1.0	73,000	137,000	4,800	NKI 85/26	0.750
85	95	115	36	1.0	107,000	223,000	4,800	NKI 85/36	1.050
90	100	120	26	1.0	76,000	146,000	4,600	NKI 90/26	0.780
90	100	120	36	1.0	111,000	237,000	4,600	NKI 90/36	1.100

Notes: 1) These values are the allowable minimum dimensions of the chamfer dimension *r*.

**MACHINED-RING NEEDLE ROLLER BEARINGS WITH INNER RING
SERIES NKI**

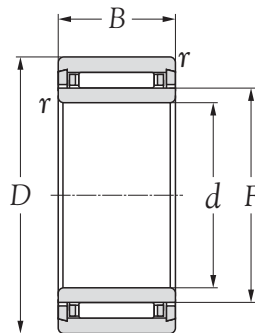

Boundary dimensions					Basic load ratings		Limiting speed	Bearing numbers	Mass
mm					dynamic	static			
<i>d</i>	<i>F</i>	<i>D</i>	<i>B</i>	<i>r</i> s min ¹⁾	N <i>C_r</i>	<i>C_{or}</i>	rpm oil		kg (approx.)
95	105	125	26	1.0	78,000	155,000	4,400	NKI 95/26	0.820
95	105	125	36	1.0	114,000	250,000	4,400	NKI 95/36	1.150
100	110	130	30	1.1	98,000	210,000	4,200	NKI 100/30	1.000
100	110	130	40	1.1	127,000	290,000	4,200	NKI 100/40	1.350

Notes: 1) These values are the allowable minimum dimensions of the chamfer dimension *r*.



THRUST ROLLER BEARINGS

1. Types and designs

NIKO Roller and Cage Thrust Assemblies are available in the series AXK, which has needle rollers; and in series K811, K812, each of which incorporates cylindrical rollers. Each pocket of the series K811 and K812 has a single row of cylindrical rollers.

Series AXK bearings, which have needle rollers, use a pressed-steel cage. Series K811, and K812 they can optionally employ a pressed-steel cage or a cage of molded polyamide reinforced with glass fiber or carbon fiber (suffix T2). The T2 cage features a maximum allowable operating temperature of 120°C and maximum allowable continuous operating temperature of 100°C .

The bearing washers for **NIKO** Thrust Roller Bearings are available in an AS model made of surface-hardened 1 mm-thick steel plate, and in WS and GS models, which are machined types.

The AS model can be used on either the shaft or housing side. This bearing washer, however, requires that the adjacent mechanical components have sufficient rigidity and good form accuracy. Before being mounted, the bearing washer may remain somewhat warped. This phenomenon should not be regarded as a problem because the warpage will be eliminated once a predetermined level of thrust load is exerted on the washer.

The bore of the WS model is fitted to a shaft, and the outside surface of the GS model is fitted to a housing.

Both models therefore provide the bearings with greater rigidity and higher running accuracy.

Bearing models 811, 812 are formed by respectively combining the roller and cage thrust assemblies of models K811 and K812 with the associated model WS or GS bearing washer.

They are standard series bearings whose dimension series, specified in JIS B 1512 (ISO 104) (Boundary dimensions for rolling bearings), are 11, 12, and 93, respectively.

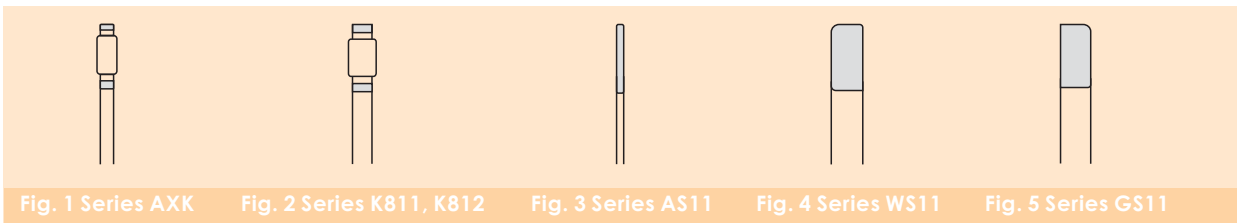

2. Interpreting bearing numbers

The bearing numbers of **NIKO** Roller and Cage Thrust Assemblies, Bearing Rings, and Thrust Roller Bearings comprise a series number, dimension series code, bore diameter number, and suffix.

Roller and cage thrust assembly

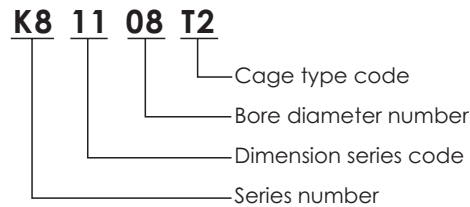
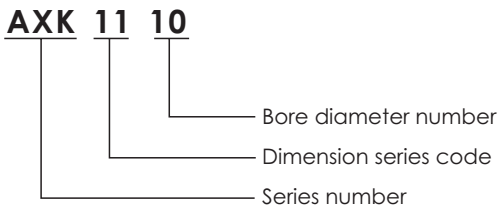

Bearing washer

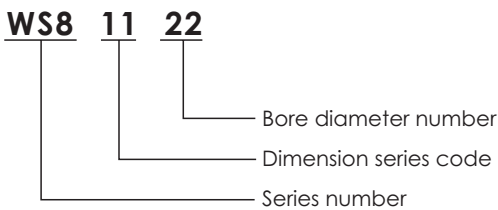

3. Bearing tolerance

The dimensional accuracy, form accuracy, and running accuracy of series 811, 812 thrust cylindrical roller bearings are given in "earing Tolerances," The bore (DeI) of rollerand cage thrust assemblies (series AXK, K811, K812) is machined to a tolerance of E11 (or E12 for bearings having a suffix T2). The outside surface (Dc) of the series AXK is machined to a tolerance of c12, while those of the series K811, K812 are machined to a tolerance of a13.

4. Raceway surface requirements

When the shaft and housing are used as a raceway for a rollerand cage thrust assembly, the raceway should satisfy the requirements in Table 1.

Table 1 Raceway requirements

Characteristics	Requirement
Squareness (max.)	IT6 (IT4)
Surface roughness	0.4α
Surface hardness	HRC58~64

5. Bearing washer fits

The fits of the shafts and housing that mount the thrust bearing washers (AS, WS, and GS models) are given in Table 2 below.

Table 2 Raceway requirements

Bearing washer	Shaft	Housing
Series AS	h10	H11
Series WS	h6	—
Series GS	—	H7

THRUST NEEDLE ROLLER BEARINGS
SERIES AXK, AS, WS, GS

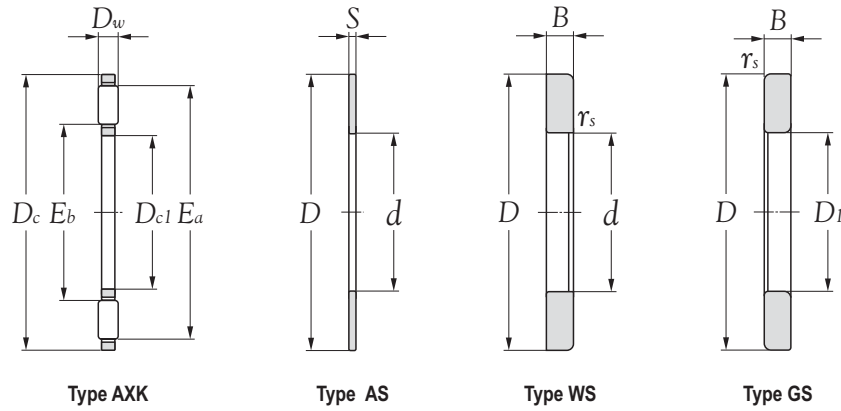

Boundary dimensions mm												Bearing numbers			
D_{c1} <i>E11</i>	D_c <i>C12</i>	D_w 0 <i>-0.01</i>	D_p <i>e13</i>	D_{p1} <i>E12</i>	$S^{2)}$ ± 0.05	d	d_1 -0.2 <i>-0.5</i>	D	D_1 $+0.5$ <i>+0.2</i>	B	r_s min ¹⁾	thrust needle roller and cage assembly (consistent with cylindrical)	Washer	Inner ring	Outer ring
10	24	2	24	10	1	10	24	24	10	2.75 ⁰ <i>-0.060</i>	0.3	AXK 1100	AS 1100	WS 1100	GS 1100
12	26	2	26	12	1	12	26	26	12	2.75 ⁰ <i>-0.060</i>	0.3	AXK 1101	AS 1101	WS 1101	GS 1101
15	28	2	28	15	1	15	28	28	16	2.75 ⁰ <i>-0.060</i>	0.3	AXK 1102	AS 1102	WS 1102	GS 1102
17	30	2	30	17	1	17	30	30	18	2.75 ⁰ <i>-0.060</i>	0.3	AXK 1103	AS 1103	WS 1103	GS 1103
20	35	2	35	20	1	20	35	35	21	2.75 ⁰ <i>-0.060</i>	0.3	AXK 1104	AS 1104	WS 1104	GS 1104
25	42	2	42	25	1	25	42	42	26	3.00 ⁰ <i>-0.060</i>	0.6	AXK 1105	AS 1105	WS 1105	GS 1105
30	47	2	47	30	1	30	47	47	32	3.00 ⁰ <i>-0.060</i>	0.6	AXK 1106	AS 1106	WS 1106	GS 1106
35	52	2	52	35	1	35	52	52	37	3.50 ⁰ <i>-0.075</i>	0.6	AXK 1107	AS 1107	WS 1107	GS 1107
40	60	3	60	40	1	40	60	60	42	3.50 ⁰ <i>-0.075</i>	0.6	AXK 1108	AS 1108	WS 1108	GS 1108
45	65	3	65	45	1	45	65	65	47	4.00 ⁰ <i>-0.075</i>	0.6	AXK 1109	AS 1109	WS 1109	GS 1109
50	70	3	70	50	1	50	70	70	52	4.00 ⁰ <i>-0.075</i>	0.6	AXK 1110	AS 1110	WS 1110	GS 1110
55	78	3	78	55	1	55	78	78	57	5.00 ⁰ <i>-0.075</i>	0.6	AXK 1111	AS 1111	WS 1111	GS 1111
60	85	3	85	60	1	60	85	85	62	4.75 ⁰ <i>-0.075</i>	1.0	AXK 1112	AS 1112	WS 1112	GS 1112
65	90	3	90	65	1	65	90	90	67	5.25 ⁰ <i>-0.075</i>	1.0	AXK 1113	AS 1113	WS 1113	GS 1113
70	95	4	95	70	1	70	95	95	72	5.25 ⁰ <i>-0.075</i>	1.0	AXK 1114	AS 1114	WS 1114	GS 1114
75	100	4	100	75	1	75	100	100	77	5.75 ⁰ <i>-0.075</i>	1.0	AXK 1115	AS 1115	WS 1115	GS 1115
80	105	4	105	80	1	80	105	105	82	5.75 ⁰ <i>-0.075</i>	1.0	AXK 1116	AS 1116	WS 1116	GS 1116
85	110	4	110	85	1	85	110	110	87	5.75 ⁰ <i>-0.075</i>	1.0	AXK 1117	AS 1117	WS 1117	GS 1117
90	120	4	120	90	1	90	120	120	92	6.50 ⁰ <i>-0.090</i>	1.0	AXK 1118	AS 1118	WS 1118	GS 1118
100	135	4	135	100	1	100	135	135	102	7.00 ⁰ <i>-0.090</i>	1.0	AXK 1120	AS 1120	WS 1120	GS 1120
110	145	4	145	110	1	110	145	145	112	7.00 ⁰ <i>-0.090</i>	1.0	AXK 1122	AS 1122	WS 1122	GS 1122
120	155	4	155	120	1	120	155	155	122	7.00 ⁰ <i>-0.090</i>	1.0	AXK 1124	AS 1124	WS 1124	GS 1124
130	170	5	170	130	1	130	170	170	132	9.00 ⁰ <i>-0.090</i>	1.0	AXK 1126	AS 1126	WS 1126	GS 1126
140	180	5	180	140	1	140	178	180	142	9.50 ⁰ <i>-0.090</i>	1.0	AXK 1128	AS 1128	WS 1128	GS 1128
150	190	5	190	150	1	150	188	190	152	9.50 ⁰ <i>-0.090</i>	1.0	AXK 1130	AS 1130	WS 1130	GS 1130
160	200	5	200	160	1	160	198	200	162	9.50 ⁰ <i>-0.090</i>	1.0	AXK 1132	AS 1132	WS 1132	GS 1132

Notes: 1) These values are the allowable minimum dimensions of the chamfer dimension r_s .
 2) Measured axial load is more than 20kgf.

THRUST NEEDLE ROLLER BEARINGS
SERIES AXK, AS, WS, GS

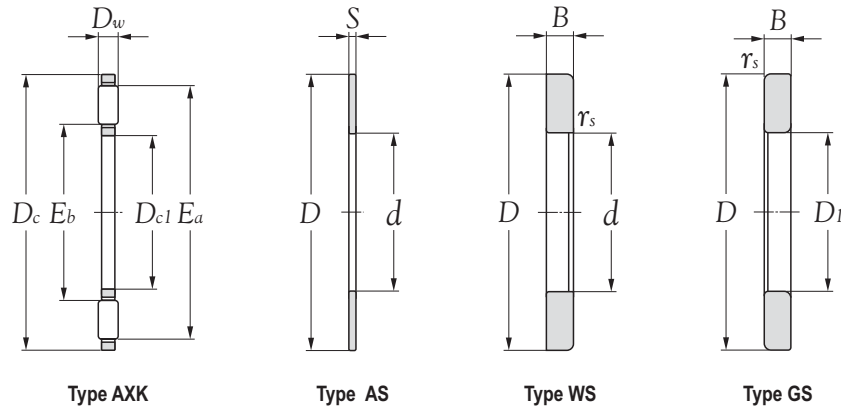

Basic load ratings				Limiting speeds		Reference dimensions		Mass		
dynamic	static	dynamic	static	rpm		mm		kg (approx.)		
C_a	C_{oa}	C_a	C_{oa}	grease	oil	E_b	E_a	AXK11	AS11	WS811 GS811
9,150	25,300	935	2,580	3,500	14,000	11	21	0.0028	0.0030	0.008
9,850	28,900	1,010	2,940	3,300	13,000	13	23	0.0030	0.0033	0.009
11,300	36,000	1,150	3,700	2,800	11,000	17	27	0.0035	0.0035	0.010
11,900	39,500	1,220	4,050	2,500	10,000	19	29	0.0040	0.0038	0.011
13,200	46,500	1,340	4,750	2,100	8,500	22	34	0.0050	0.0051	0.014
14,600	58,000	1,490	5,900	1,800	7,000	29	41	0.0070	0.0070	0.021
16,300	69,500	1,660	7,100	1,500	6,000	35	46	0.0080	0.0080	0.025
17,800	81,500	1,820	8,300	1,400	5,500	40	51	0.0010	0.0091	0.033
27,400	110,000	2,790	11,300	1,200	4,700	45	58	0.0185	0.0123	0.044
29,800	128,000	3,050	13,100	1,100	4,300	50	63	0.0205	0.0136	0.055
31,500	143,000	3,250	14,500	1,000	3,900	55	68	0.0235	0.0148	0.060
38,000	186,000	3,850	19,000	900	3,500	60	76	0.0308	0.0189	0.095
44,500	234,000	4,550	23,900	800	3,200	65	83	0.0390	0.0223	0.101
46,500	254,000	4,750	25,900	750	3,000	70	88	0.0400	0.0239	0.125
53,500	253,000	5,500	25,800	750	2,900	74	93	0.0600	0.0254	0.134
55,000	266,000	5,650	27,100	700	2,700	79	98	0.0610	0.0270	0.155
56,500	279,000	5,750	28,400	650	2,600	84	103	0.0630	0.0284	0.163
57,500	291,000	5,900	29,700	600	2,400	89	108	0.0668	0.0301	0.175
71,000	390,000	7,250	39,500	600	2,300	94	118	0.0860	0.0388	0.250
90,500	550,000	9,200	56,500	500	2,000	105	133	0.1120	0.0505	0.350
93,500	590,000	9,550	60,500	480	1,900	115	143	0.1220	0.0549	0.385
99,000	650,000	10,100	66,500	430	1,700	125	153	0.1310	0.0592	0.415
140,000	900,000	14,300	92,000	400	1,600	136	167	0.2050	0.0740	0.663
145,000	960,000	14,800	97,500	380	1,500	146	177	0.2190	0.0790	0.749
149,000	1,020,000	15,200	104,000	350	1,400	156	187	0.2320	0.0840	0.796
154,000	1,070,000	15,700	110,000	330	1,300	166	197	0.2460	0.0890	0.842

**THRUST NEEDLE ROLLER BEARINGS
SERIES LS**

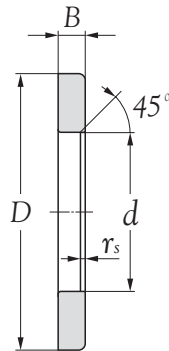

Boundary dimensions				Roll path size		Basic load ratings		Limiting speed $n_{\text{grease}} \approx$ min^{-1}	Bearing numbers
d	D	B	$r_{s \text{ min.}}$	E_b	E_a	dynamic N C_r	static C_{or}		
6	19	2.75	0.3	7	18	6,800	15,500	16,000	LS 0619
8	21	2.75	0.3	9	20	7,800	19,400	15,000	LS 0821
10	24	2.75	0.3	12	23	9,200	25,500	14,000	LS 1024
12	26	2.75	0.3	14	25	9,900	29,000	13,000	LS 1226
15	28	2.75	0.3	17	27	11,300	36,000	11,000	LS 1528
17	30	2.75	0.3	19	29	11,900	39,500	10,000	LS 1730
20	35	2.75	0.3	22	34	13,100	46,500	8,500	LS 2035
25	42	3.00	0.6	29	41	14,700	58,000	7,000	LS 2542
30	47	3.00	0.6	34	46	16,300	70,000	6,000	LS 3047
35	52	3.50	0.6	39	51	17,800	81,000	5,500	LS 3552
40	60	3.50	0.6	45	58	28,000	114,000	4,700	LS 4060
45	65	4.00	0.6	50	63	30,000	128,000	4,300	LS 4565
50	70	4.00	0.6	55	68	32,000	143,000	3,900	LS 5070
55	78	5.00	0.6	60	76	38,000	186,000	3,500	LS 5578
60	85	4.75	1.0	65	83	44,500	234,000	3,200	LS 6085
65	90	5.25	1.0	70	88	46,500	255,000	3,000	LS 6090
70	95	5.25	1.0	74	93	54,000	255,000	2,900	LS 7095
75	100	5.75	1.0	79	98	55,000	265,000	2,700	LS 75100
80	105	5.75	1.0	84	103	56,000	280,000	2,600	LS 80105
85	110	5.75	1.0	89	108	58,000	290,000	2,400	LS 85110
90	120	6.50	1.0	94	118	73,000	405,000	2,300	LS 90120
100	135	7.00	1.0	105	133	91,000	560,000	2,000	LS 100135
110	145	7.00	1.0	115	143	97,000	620,000	1,900	LS 110145

THRUST NEEDLE ROLLER BEARINGS
SERIES K 811

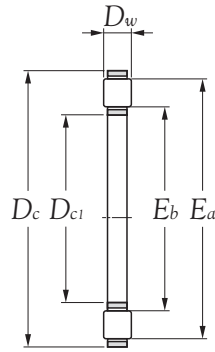

Type K 811

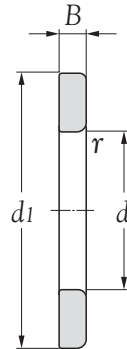

Type WS
(Inner ring)

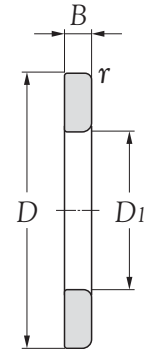

Type GS
(Outer ring)

Boundary dimensions			Reference dimensions		Basic load ratings				Limiting speeds		Bearing numbers			Mass
mm			mm		dynamic	static	dynamic	static	rpm		thrust needle roller and cage assembly	Inner ring	Outer ring	kg
$D_{ci}^{1)}$	D_c	D_w	E_b	E_a	N	kgf	kgf	grease	oil	(approx.)				
$E11$	0.13	$\begin{matrix} 0 \\ -0.010 \end{matrix}$			C_r	C_{or}	C_r	C_{or}						
10	24	3.5	12	23	10,800	21,500	1,110	2,190	3,400	13,000	K 81100	WS 81100	GS 81100	0.0035
12	26	3.5	14	25	11,500	23,900	1,170	2,430	3,000	12,000	K 81101	WS 81101	GS 81101	0.0040
15	28	3.5	16	27	12,900	28,600	1,310	2,920	2,800	11,000	K 81102	WS 81102	GS 81102	0.0060
17	30	3.5	18	29	13,400	31,000	1,370	3,150	2,500	10,000	K 81103	WS 81103	GS 81103	0.0080
20	35	4.5	21	34	20,200	46,500	2,060	4,700	2,100	8,500	K 81104	WS 81104	GS 81104	0.0120
25	42	5.0	27	40	27,300	68,000	2,780	6,900	1,800	7,000	K 81105	WS 81105	GS 81105	0.0180
30	47	5.0	32	45	27,800	72,500	2,840	7,400	1,500	6,000	K 81106	WS 81106	GS 81106	0.0200
35	52	5.0	37	50	31,000	87,000	3,150	8,900	1,400	5,500	K 81107	WS 81107	GS 81107	0.0240
40	60	6.0	42	58	43,000	121,000	4,350	12,400	1,200	4,800	K 81108	WS 81108	GS 81108	0.0350
45	65	6.0	47	63	45,500	135,000	4,650	13,800	1,100	4,400	K 81109	WS 81109	GS 81109	0.0400
50	70	6.0	52	68	48,000	150,000	4,900	15,300	1,000	4,000	K 81110	WS 81110	GS 81110	0.0450
55	78	6.0	57	76	62,500	215,000	6,350	21,900	900	3,600	K 81111	WS 81111	GS 81111	0.0600
60	85	7.5	63	82	69,000	215,000	7,000	21,900	830	3,300	K 81112	WS 81112	GS 81112	0.0830
65	90	7.5	68	87	73,000	236,000	7,400	24,100	780	3,100	K 81113	WS 81113	GS 81113	0.0900
70	95	7.5	73	92	76,500	257,000	7,800	26,200	730	2,900	K 81114	WS 81114	GS 81114	0.0970
75	100	7.5	78	97	78,000	268,000	7,950	27,300	680	2,700	K 81115	WS 81115	GS 81115	0.1150
80	105	7.5	83	102	79,500	279,000	8,100	28,400	650	2,600	K 81116	WS 81116	GS 81116	0.1190
85	110	7.5	88	107	83,000	300,000	8,450	30,500	630	2,500	K 81117	WS 81117	GS 81117	0.1250
90	120	9.0	93	117	112,000	395,000	11,400	40,500	580	2,300	K 81118	WS 81118	GS 81118	0.1700

Notes: 1) The dimensional tolerance for a bearing with a T2 suffix is E12.

THRUST NEEDLE ROLLER BEARINGS
SERIES K 812

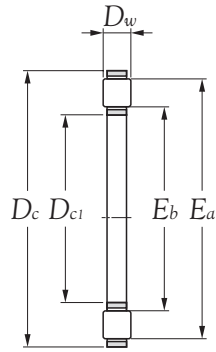

Type K 812

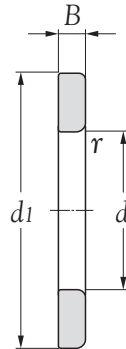

Type WS
(Inner ring)

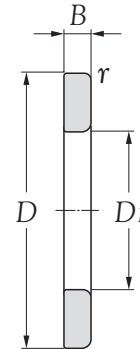

Type GS
(Outer ring)

Boundary dimensions			Reference dimensions		Basic load ratings				Limiting speeds		Bearing numbers			Mass
mm			mm		dynamic	static	dynamic	static	rpm		thrust needle roller and cage assembly	Inner ring	Outer ring	kg
$D_{c1}^{1)}$	D_c	D_w	E_b	E_a	N	kgf	kgf	grease	oil	(approx.)				
$E11$	0.13	$\begin{matrix} 0 \\ -0.010 \end{matrix}$			C_r	C_{or}	C_r	C_{or}						
30	52	7.5	32	50	53,500	129,000	5,450	13,100	1,500	6,000	K 81206	WS 81206	GS 81206	0.050
35	62	7.5	37	60	54,500	139,000	5,550	14,200	1,200	4,900	K 81207	WS 81207	GS 81207	0.065
40	68	9.0	43	66	74,500	190,000	7,600	19,400	1,100	4,400	K 81208	WS 81208	GS 81208	0.085
45	73	9.0	48	71	82,000	222,000	8,350	22,600	1,000	4,100	K 81209	WS 81209	GS 81209	0.100
50	78	9.0	53	76	85,000	238,000	8,650	24,200	950	3,800	K 81210	WS 81210	GS 81210	0.105
55	90	11.0	58	87	121,000	340,000	12,300	34,500	830	3,300	K 81211	WS 81211	GS 81211	0.190
60	95	11.0	64	92	125,000	365,000	12,800	37,000	780	3,100	K 81212	WS 81212	GS 81212	0.200
65	100	11.0	69	97	130,000	385,000	13,200	39,500	730	2,900	K 81213	WS 81213	GS 81213	0.215
70	105	11.0	74	102	134,000	410,000	13,700	42,000	680	2,700	K 81214	WS 81214	GS 81214	0.225
75	110	11.0	79	107	138,000	435,000	14,100	44,500	650	2,600	K 81215	WS 81215	GS 81215	0.240
80	115	11.0	84	112	142,000	460,000	14,500	47,000	630	2,500	K 81216	WS 81216	GS 81216	0.250

Notes: 1) The dimensional tolerance for a bearing with a T2 suffix is E12.



COMPLEX BEARINGS

1. Types and designs

Depending on the thrust bearing type that is combined with a radial needle roller bearing, **NIKO** Complex Bearings can be categorized as thrust ball bearings (series NKX), thrust cylindrical roller bearings (series NKXR). The series NKX and NKXR complex bearings can carry a relatively large axial load in one direction and can be axially located.

When used in opposing pairs, they can bear an axial load in both directions and can be axially located. However, because they cannot accommodate a greater axial expansion, they should be mounted on a shorter shaft whose axial expansion is small.

The variant with a dust-proofing cover on its thrust bearing (suffix Z) is easily handled because the thrust bearing is a non-separable type. This arrangement can also prevent splashing of the grease within the thrust bearing.

Generally, radial needle roller bearings in these complex bearings use a shaft as a raceway surface, without using an inner ring. However, they can incorporate an inner ring when a shaft is inappropriate as a raceway surface.

The tolerance class of the inscribed enveloping circle diameter (Fw) with needle roller bearings is class F6, the same as with machined ring needle roller bearings.

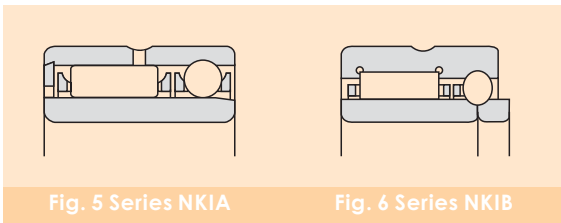
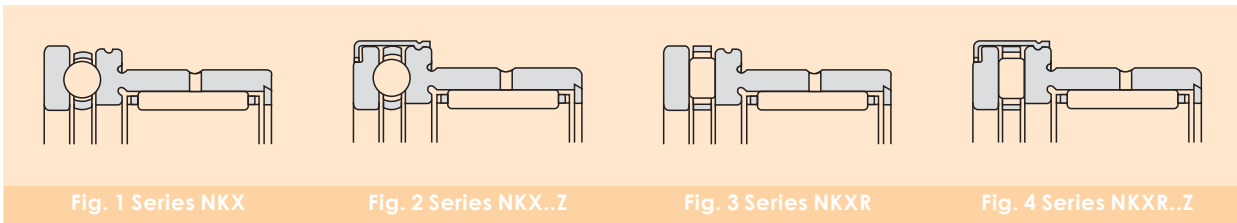

2. Interpreting bearing numbers

The bearing numbers of **NIKO** Complex Bearings comprise a series number, dimension series code, Dimension code, and suffix.

Series NKX, NKXR

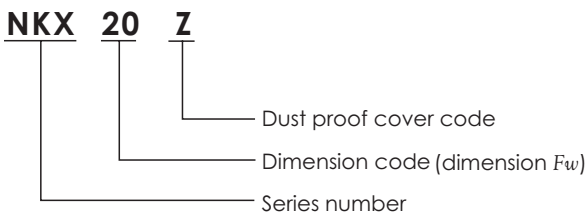

Series NKIA, NKIB

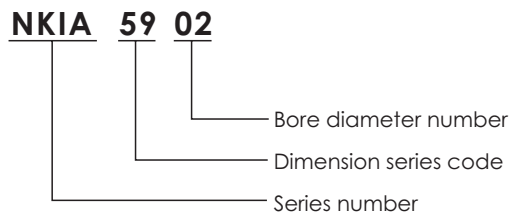

3. Bearing fits

Table 1 summarizes the fits of radial needle roller bearings to a shaft and housing. The thrust bearing washers of series NKX and NKXR bearings are installed in a housing whose bore diameter is at least 0.5 mm larger than the outside diameter D₁ or D₂ of the bearing washer.

Table 1 Fit to shaft and housing

Bearing number	Shaft	Housing
Series NKX,NKXR	k5	K6(M6)
Series NKIA,NKIB	k5	M6

Remarks: Fits appearing in parentheses are for applications requiring greater rigidity.

4. Rating life calculation

The rating life (*L*) of a complex bearings can be determined by inputting the results of the following calculations into the formula below:

Calculate the rating life (*L_r*) of the radial needle roller bearing according to the working radial load.

Calculate the rating life (*L_a*) of the thrust bearing according to the working axial load.

$$L = \frac{1}{\left(\frac{1}{L_r^{1.1}} + \frac{1}{L_a^{1.1}}\right)^{0.91}} \dots\dots\dots(1)$$

NEEDLE ROLLER BEARINGS WITH THRUST BALL BEARINGS
SERIES NKX, NKX..Z

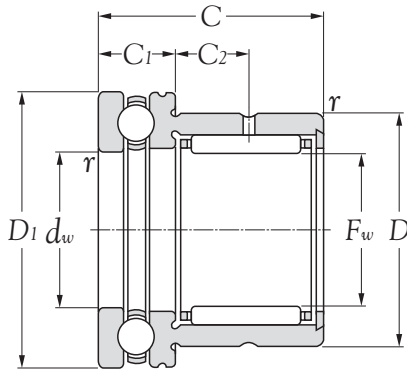

Type NKX
(Open type)

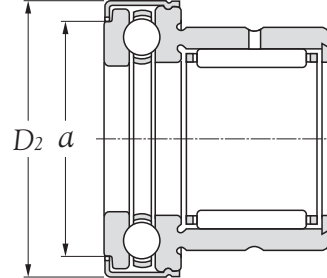

Type NKX..Z
(With cover)

Boundary dimensions										Basic load ratings				Bearing numbers				
F_w	d_w	D	D_1	mm			a	$r_s \text{ min}^{1)}$	dynamic	static	dynamic	static						
				D_2	C	C_1										C_2	N	kgf
													Radial					
													C_r	C_{or}				
10	$^{+0.022}_{+0.013}$	10	$^{+0.040}_{+0.025}$	19	24	25.0	23	9	6.5	19.7	0.3		5,450	6,450	555	660	NKX 10 T2	NKX 10 T2Z
12	$^{+0.027}_{+0.016}$	12	$^{+0.050}_{+0.032}$	21	26	27.0	23	9	6.5	21.7	0.3		6,000	7,700	615	785	NKX 12 T2	NKX 12 T2Z
15	$^{+0.027}_{+0.016}$	15	$^{+0.050}_{+0.032}$	24	28	29.0	23	9	6.5	23.7	0.3		8,250	10,200	840	1,040	NKX 15 T2	NKX 15 T2Z
17	$^{+0.027}_{+0.016}$	17	$^{+0.050}_{+0.032}$	26	30	31.0	25	9	8.0	25.7	0.3		10,400	14,400	1,060	1,460	NKX 17 T2	NKX 17 T2Z
20	$^{+0.033}_{+0.020}$	20	$^{+0.061}_{+0.040}$	30	35	36.0	30	10	10.5	30.7	0.3		16,400	27,100	1,670	2,760	NKX 20 T2	NKX 20 T2Z
25	$^{+0.033}_{+0.020}$	25	$^{+0.061}_{+0.040}$	37	42	43.0	30	11	9.5	37.7	0.6		14,200	24,000	1,450	2,450	NKX 25 T2	NKX 25 T2Z
30	$^{+0.033}_{+0.020}$	30	$^{+0.061}_{+0.040}$	42	47	48.0	30	11	9.5	42.7	0.6		22,300	39,500	2,280	4,000	NKX 30 T2	NKX 30 T2Z
35	$^{+0.041}_{+0.025}$	35	$^{+0.075}_{+0.050}$	47	52	53.0	30	12	9.0	47.7	0.6		20,000	36,000	2,040	3,650	NKX 35 T2	NKX 35 T2Z
40	$^{+0.041}_{+0.025}$	40	$^{+0.075}_{+0.050}$	52	60	61.0	32	13	10.0	55.7	0.6		25,900	52,500	2,650	5,350	NKX 40	NKX 40 Z
45	$^{+0.041}_{+0.025}$	45	$^{+0.075}_{+0.050}$	58	65	66.5	32	14	9.0	60.5	0.6		27,600	59,000	2,810	6,000	NKX 45	NKX 45 Z
50	$^{+0.041}_{+0.025}$	50	$^{+0.075}_{+0.050}$	62	70	71.5	35	14	10.0	65.5	0.6		27,900	62,000	2,850	6,300	NKX 50	NKX 50 Z
60	$^{+0.049}_{+0.030}$	60	$^{+0.090}_{+0.060}$	72	85	86.5	40	17	12.0	80.5	1.0		29,800	71,500	3,050	7,300	NKX 60	NKX 60 Z
70	$^{+0.049}_{+0.030}$	70	$^{+0.090}_{+0.060}$	85	95	96.5	40	18	11.0	90.5	1.0		36,500	86,000	3,700	8,750	NKX 70	NKX 70 Z

Notes: 1) These values are the allowable minimum dimensions of the chamfer dimension r .

NEEDLE ROLLER BEARINGS WITH THRUST BALL BEARINGS
SERIES NKX, NKX..Z

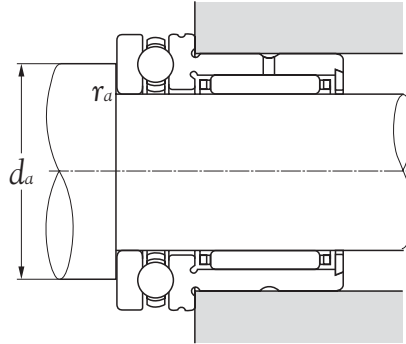

Basic load ratings				Abutment dimensions		Limiting speeds		Bearing numbers		Mass	
dynamic	static	dynamic	static	da min	ras max	rpm				kg	
N		kgf				grease	oil			Type	Type
Ca	Coa	Ca	Coa							NKX	NKX..Z
10,000	14,000	1,020	1,420	18	0.3	6,700	9,500	NKX 10 T2	NKX 10 T2Z	0.037	0.039
10,300	15,400	1,050	1,570	20	0.3	6,400	9,200	NKX 12 T2	NKX 12 T2Z	0.042	0.044
10,500	16,800	1,070	1,710	23	0.3	6,200	8,800	NKX 15 T2	NKX 15 T2Z	0.044	0.048
10,800	18,200	1,100	1,850	25	0.3	6,000	8,500	NKX 17 T2	NKX 17 T2Z	0.051	0.056
14,200	24,700	1,450	2,520	29	0.3	5,200	7,500	NKX 20 T2	NKX 20 T2Z	0.085	0.090
19,600	37,000	1,990	3,800	35	0.6	4,600	6,500	NKX 25 T2	NKX 25 T2Z	0.125	0.132
20,400	42,000	2,080	4,300	40	0.6	4,300	6,200	NKX 30 T2	NKX 30 T2Z	0.140	0.148
20,400	44,500	2,080	4,550	45	0.6	3,900	5,600	NKX 35 T2	NKX 35 T2Z	0.167	0.175
26,900	63,000	2,740	6,400	52	0.6	3,500	5,000	NKX 40	NKX 40 Z	0.216	0.225
27,900	69,000	2,840	7,050	57	0.6	3,200	4,600	NKX 45	NKX 45 Z	0.252	0.265
28,800	75,500	2,930	7,700	62	0.6	3,100	4,500	NKX 50	NKX 50 Z	0.302	0.318
41,500	113,000	4,200	11,500	75	1.0	2,600	3,700	NKX 60	NKX 60 Z	0.465	0.484
43,000	127,000	4,400	12,900	85	1.0	2,400	3,400	NKX 70	NKX 70 Z	0.612	0.635

NEEDLE ROLLER BEARINGS WITH THRUST CYLINDRICAL ROLLER BEARINGS
SERIES NKXR, NKXR..Z

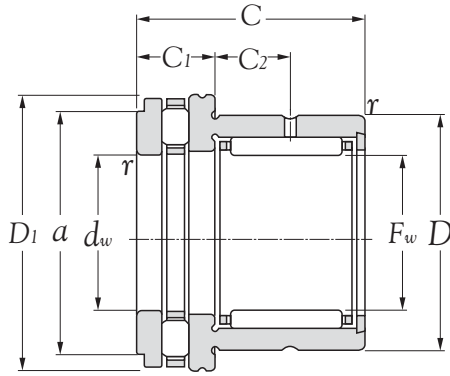

Type NKXR
(Open type)

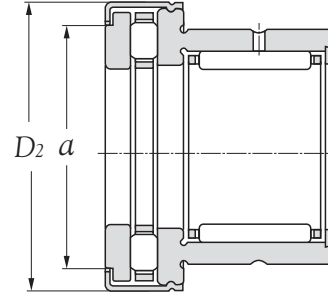

Type NKXR..Z
(With cover)

Boundary dimensions											Basic load ratings				Bearing numbers	
F _w	d _w	D	D ₁	mm			C	C ₁	C ₂	a	r s min ¹⁾	dynamic N	static N	dynamic static kgf		
				D ₂	C	C ₁								C ₂		Cr
15 ^{+0.027} _{+0.016}	15 ^{+0.050} _{+0.032}	24	28	29.0	23 ₀ ^{-0.25}	9 ₀ ^{-0.20}	6.5	23.7	0.3	8,250	10,200	840	1,040	NKXR 15 T2 NKXR 15 T2Z		
17 ^{+0.027} _{+0.016}	17 ^{+0.050} _{+0.032}	26	30	31.0	25	9	8.0	25.7	0.3	10,400	14,400	1,060	1,460	NKXR 17 T2 NKXR 17 T2Z		
20 ^{+0.033} _{+0.020}	20 ^{+0.061} _{+0.040}	30	35	36.0	30	10	10.5	30.7	0.3	16,400	27,100	1,670	2,760	NKXR 20 T2 NKXR 20 T2Z		
25 ^{+0.033} _{+0.020}	25 ^{+0.061} _{+0.040}	37	42	43.0	30	11	9.5	37.7	0.6	14,200	24,000	1,450	2,450	NKXR 25 T2 NKXR 25 T2Z		
30 ^{+0.033} _{+0.020}	30 ^{+0.061} _{+0.040}	42	47	48.0	30	11	9.5	42.7	0.6	22,300	39,500	2,280	4,000	NKXR 30 T2 NKXR 30 T2Z		
35 ^{+0.041} _{+0.025}	35 ^{+0.075} _{+0.050}	47	52	53.0	30	12	9.0	47.7	0.6	20,000	36,000	2,040	3,650	NKXR 35 T2 NKXR 35 T2Z		
40 ^{+0.041} _{+0.025}	40 ^{+0.075} _{+0.050}	52	60	61.0	32	13	10.0	55.7	0.6	25,900	52,500	2,650	5,350	NKXR 40 T2 NKXR 40 T2Z		
45 ^{+0.041} _{+0.025}	45 ^{+0.075} _{+0.050}	58	65	66.5	32	14	9.0	60.5	0.6	27,600	59,000	2,810	6,000	NKXR 45 T2 NKXR 45 T2Z		
50 ^{+0.041} _{+0.025}	50 ^{+0.075} _{+0.050}	62	70	71.5	35	14	10.0	65.5	0.6	27,900	62,000	2,850	6,300	NKXR 50 T2 NKXR 50 T2Z		

Notes: 1) These values are the allowable minimum dimensions of the chamfer dimension r.

**NEEDLE ROLLER BEARINGS WITH THRUST CYLINDRICAL ROLLER BEARINGS
SERIES NKXR, NKXR..Z**

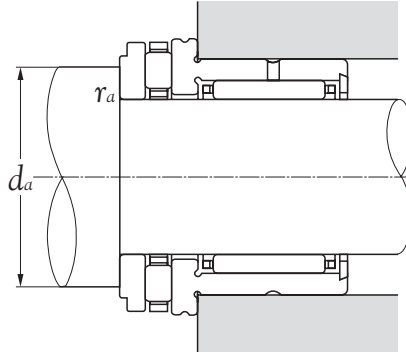

Basic load ratings				Abutment dimensions		Limiting speeds		Bearing numbers		Mass kg (approx.)	
dynamic N		static kgf		d_a min	r_{as} max	rpm				Type NKXR	Type NKXR..Z
C_a	C_{oa}	Axial C_a	C_{oa}			grease	oil				
12,900	28,600	1,310	2,920	25	0.3	2,800	11,000	NKXR 15 T2	NKXR 15 T2Z	0.048	0.052
13,400	31,000	1,370	3,150	27	0.3	2,500	10,000	NKXR 17 T2	NKXR 17 T2Z	0.050	0.053
20,200	46,500	2,060	4,700	32	0.3	2,100	8,500	NKXR 20 T2	NKXR 20 T2Z	0.090	0.095
27,300	68,000	2,780	6,900	39	0.6	1,800	7,000	NKXR 25 T2	NKXR 25 T2Z	0.128	0.135
27,800	72,500	2,840	7,400	44	0.6	1,500	6,000	NKXR 30 T2	NKXR 30 T2Z	0.162	0.169
31,000	87,000	3,150	8,900	49	0.6	1,400	5,500	NKXR 35 T2	NKXR 35 T2Z	0.184	0.195
43,000	121,000	4,350	12,400	56	0.6	1,200	4,800	NKXR 40 T2	NKXR 40 T2Z	0.226	0.237
45,500	135,000	4,650	13,800	61	0.6	1,100	4,400	NKXR 45 T2	NKXR 45 T2Z	0.267	0.286
48,000	150,000	4,900	15,300	66	0.6	1,000	4,000	NKXR 50 T2	NKXR 50 T2Z	0.309	0.329

NEEDLE ROLLER BEARINGS WITH ANGULAR CONTACT BALL BEARINGS
SERIES NKIA 59

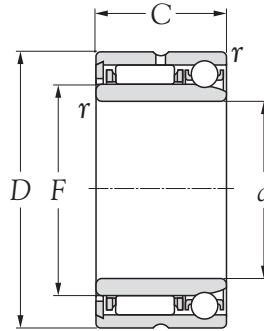

Boundary dimensions					Basic load ratings								Bearing numbers
mm					dynamic N	static	dynamic kgf	static	dynamic N	static	dynamic kgf	static	
<i>d</i>	<i>D</i>	<i>C</i>	<i>F</i>	<i>r</i> <small>min¹⁾</small>	Radial				Axial				
					<i>C_r</i>	<i>C_{or}</i>	<i>C_r</i>	<i>C_{or}</i>	<i>C_a</i>	<i>C_{oa}</i>	<i>C_a</i>	<i>C_{oa}</i>	
15	28	18	20	0.3	9,500	13,400	970	1,370	2,340	3,050	239	310	NKIA 5902
17	30	18	22	0.3	10,100	14,900	1,030	1,520	2,530	3,550	258	360	NKIA 5903
20	37	23	25	0.3	16,500	22,100	1,680	2,250	4,700	6,150	480	625	NKIA 5904
22	39	23	28	0.3	17,500	24,800	1,790	2,530	4,900	6,750	500	690	NKIA 59/22
25	42	23	30	0.3	17,400	25,000	1,770	2,550	5,100	7,350	520	750	NKIA 5905
30	47	23	35	0.3	19,400	30,500	1,980	3,100	5,400	8,550	550	870	NKIA 5906
35	55	27	42	0.6	25,700	46,000	2,630	4,700	7,400	12,300	755	1,260	NKIA 5907
40	62	30	48	0.6	31,000	61,000	3,150	6,250	7,750	14,000	790	1,430	NKIA 5908
45	68	30	55	0.6	33,000	69,500	3,350	7,100	8,500	17,100	870	1,740	NKIA 5909
50	72	30	60	0.6	33,500	73,500	3,450	7,500	8,800	18,700	900	1,910	NKIA 5910
55	80	34	63	1.0	44,500	95,500	4,500	9,700	14,300	33,000	1,460	3,350	NKIA 5911
60	85	34	68	1.0	45,500	101,000	4,600	10,300	14,800	36,000	1,510	3,650	NKIA 5912
65	90	34	75	1.0	46,000	106,000	4,700	10,800	15,200	39,000	1,550	4,000	NKIA 5913
70	100	40	80	1.0	62,500	146,000	6,350	14,900	18,600	47,500	1,890	4,850	NKIA 5914

Notes: 1) These values are the allowable minimum dimensions of the chamfer dimension *r*.

NEEDLE ROLLER BEARINGS WITH ANGULAR CONTACT BALL BEARINGS
SERIES NKIA 59

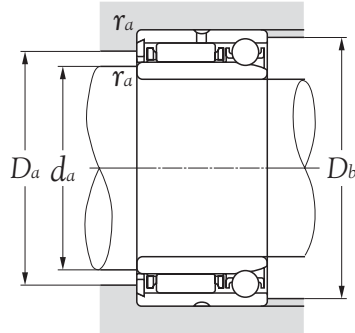

Limiting speeds rpm		Abutment dimensions mm				Bearing numbers	Mass kg (approx.)
grease	oil	d_a min	D_a max	D_b max	r_{as} max		
13,000	20,000	17.5	22.0	25.5	0.3	NKIA 5902	0.050
12,000	18,000	19.5	24.0	27.5	0.3	NKIA 5903	0.056
11,000	16,000	22.5	28.0	34.5	0.3	NKIA 5904	0.111
9,500	14,000	24.5	31.0	36.5	0.3	NKIA 59/22	0.120
8,500	13,000	27.5	33.0	39.5	0.3	NKIA 5905	0.130
7,500	11,000	32.5	38.0	44.5	0.3	NKIA 5906	0.147
6,500	9,500	40.0	45.0	50.0	0.6	NKIA 5907	0.243
5,500	8,500	45.0	51.0	57.0	0.6	NKIA 5908	0.347
5,000	7,500	50.0	58.0	63.0	0.6	NKIA 5909	0.401
4,300	6,500	55.0	63.0	67.0	0.6	NKIA 5910	0.410
4,300	6,500	61.0	66.5	74.0	1.0	NKIA 5911	0.590
4,000	6,000	66.0	71.5	79.0	1.0	NKIA 5912	0.632
3,700	5,500	71.0	78.5	84.0	1.0	NKIA 5913	0.708
3,300	5,000	76.0	84.0	94.0	1.0	NKIA 5914	1.050

NEEDLE ROLLER BEARINGS WITH THREE-POINT CONTACT BALL BEARINGS
SERIES NKIB 59

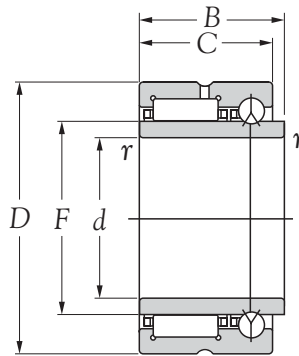

Boundary dimensions						Basic load ratings							
mm						dynamic	static	dynamic	static	dynamic	static	dynamic	static
<i>d</i>	<i>D</i>	<i>B</i>	<i>C</i>	<i>F</i>	<i>r</i> min ¹⁾	N	Radial	kgf	N	N	kgf	N	kgf
						<i>C_r</i>	<i>C_{or}</i>	<i>C_r</i>	<i>C_{or}</i>	<i>C_a</i>	<i>C_{oa}</i>	<i>C_a</i>	<i>C_{oa}</i>
											Axiall		
15	28	20	18	20	0.3	10,800	13,600	1,100	1,390	2,750	4,200	280	430
17	30	20	18	22	0.3	11,200	14,600	1,140	1,490	2,960	4,900	300	495
20	37	25	23	25	0.3	21,300	25,500	2,170	2,600	4,650	7,400	475	755
22	39	25	23	28	0.3	23,200	29,300	2,360	2,990	5,000	8,650	510	880
25	42	25	23	30	0.3	24,000	31,500	2,450	3,200	5,150	9,250	525	945
30	47	25	23	35	0.3	25,500	35,500	2,600	3,600	5,600	11,200	570	1.140
35	55	30	42	42	0.6	32,000	50,000	3,300	5,100	7,050	14,900	720	1.520
40	62	34	48	28	0.6	43,500	66,500	4,450	6,800	8,700	19,400	890	1.980
45	68	34	52	52	0.6	46,000	73,000	4,700	7,450	9,100	21,400	925	2.180
50	72	34	58	58	0.6	48,000	80,000	4,900	8,150	9,600	24,300	980	2.480
55	80	38	63	63	1.0	58,500	99,500	6,000	10,100	11,400	29,400	1,170	3.000
60	85	38	68	68	1.0	61,500	108,000	6,250	11,000	11,800	32,000	1,200	3.250
65	90	38	72	72	1.0	62,500	112,000	6,350	11,400	12,100	34,000	1,240	3.500
70	100	45	80	80	1.0	85,500	156,000	8,750	15,900	15,900	44,500	1,620	4.550

Notes: 1) These values are the allowable minimum dimensions of the chamfer dimension *r*.

NEEDLE ROLLER BEARINGS WITH THREE-POINT CONTACT BALL BEARINGS
SERIES NKIB 59

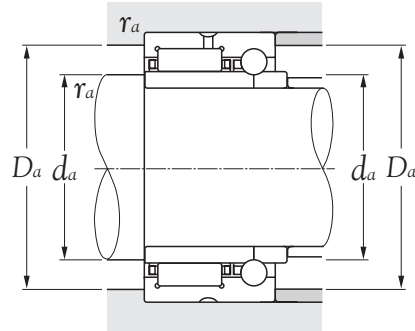

Limiting speeds rpm		Abutment dimensions mm			Bearing numbers	Mass kg (approx.)
grease	oil	d_a min	D_a max	r_{as} max		
13,000	20,000	17.5	25.5	0.3	NKIB 5902 R	0.052
12,000	18,000	19.5	27.5	0.3	NKIB 5903 R	0.058
11,000	16,000	22.5	34.5	0.3	NKIB 5904 R	0.107
9,500	14,000	24.5	36.5	0.3	NKIB 59/22 R	0.122
8,500	13,000	27.5	39.5	0.3	NKIB 5905 R	0.134
7,500	11,000	32.5	44.5	0.3	NKIB 5906 R	0.151
6,500	9,500	40.0	50.0	0.6	NKIB 5907 R	0.247
5,500	8,500	45.0	57.0	0.6	NKIB 5908 R	0.320
5,000	7,500	50.0	63.0	0.6	NKIB 5909 R	0.380
4,300	6,500	55.0	67.0	0.6	NKIB 5910 R	0.385
4,300	6,500	61.0	74.0	1.0	NKIB 5911 R	0.555
4,000	6,000	66.0	79.0	1.0	NKIB 5912 R	0.595
3,700	5,500	71.0	84.0	1.0	NKIB 5913 R	0.640
3,300	5,000	76.0	94.0	1.0	NKIB 5914 R	0.985



NOTE

AUTOMATION TECHNOLOGY



ROLLER FOLLOWERS

1. Types and designs

NIKO Yoke-type Track Rollers include the series RNA22 (without inner ring) and series NA22 (with inner ring), whose outer ring is not guided in the axial direction; and the NATR, NATV and series NUTR whose outer ring is guided in the axial direction.

With the series RNA22 and NA22, a needle roller and cage assembly and steel plate reinforced synthetic rubber seal are built into the outer ring, and these components are inseparable from each other. Since the bearing can be shifted in the axial direction, the shaft must have a thrust washer or flange to guide the outer ring.

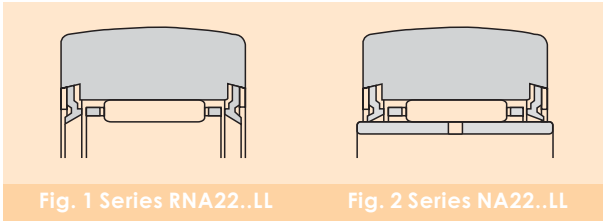

With the series NATR, NATV, the outer ring is guided in the axial direction by two side plates that are press-fit into the inner ring. The series NATR bearing has an integral cage and needle roller assembly. The series NATV full-complement type can carry a larger load compared with the series NATR bearing, although its limiting speed is low.

On **NIKO** Yoke-type Track Rollers, a labyrinth occurs between the outer ring and inner ring to provide sealing. For enhanced sealing, one type of bearing (suffix LL) incorporates a synthetic rubber seal between the outer ring and inner ring.

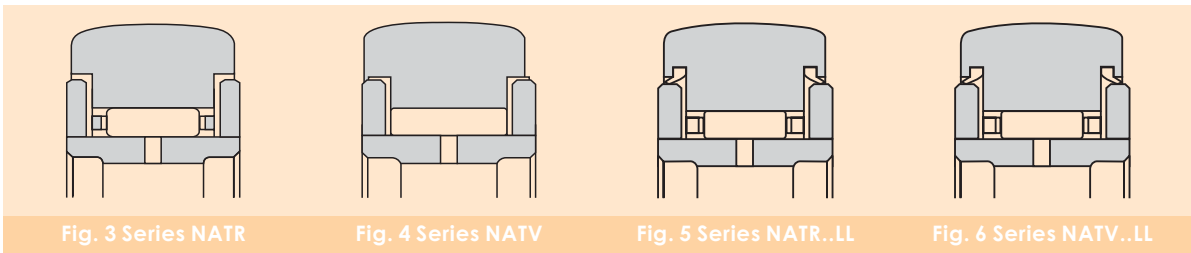

The rollers of the series NUTR are full-complement type rollers whose rolling elements are double-row cylindrical rollers. Compared with full-complement needle roller bearings, they feature greater load carrying capacity and thus are suitable for heavy load applications. Their outer ring incorporates a press-fit steel plate to form a labyrinth between the side plates on both sides of the inner ring to ensure reliable sealing and maintain the position of the side plates. The outer ring is guided in the axial direction by the outer ring rib and end faces of the cylindrical rollers, and can carry some axial load. The inner ring and side plates are tightened in the axial direction to eliminate clearance.

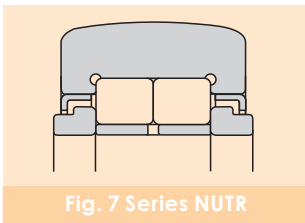

2. Interpreting bearing numbers

The bearing numbers of **NIKO** Yoke-type Track Rollers comprise a series number, dimension series code, dimension code, and suffix.

Series RNA, NA

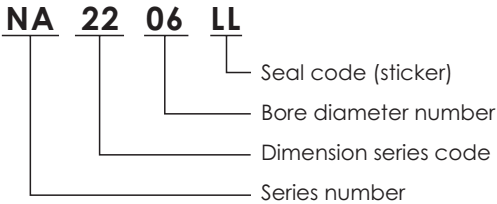

Series NATR, NATV

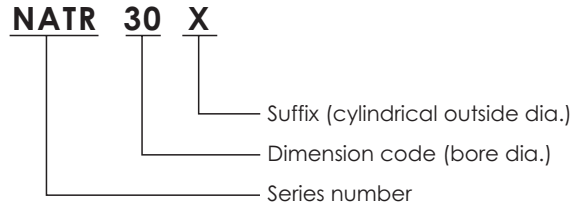

Series NUTR

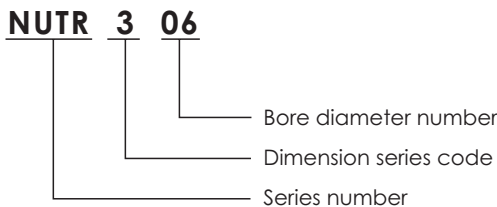

3. Bearing fits and radial clearance

The tolerance class of the shaft in relation to a bearing with an inner ring is g6 (h6). If a shaft is used directly as a raceway surface (series RNA22), the tolerance class of the shaft must be k5 (k6). Usually, the outer ring of an **NIKO** Yoke-type Track Roller is not built into a housing.

Table 1 Radial clearance

(Unit: μm)

Enveloping circle diameter F_w (mm)		Clearance							
		C2		Normal		C3		C4	
		min.	max.	min.	max.	min.	max.	min.	max.
over 3	incl. 6	0	10	3	17	15	30	20	40
6	10	0	12	5	20	15	30	25	45
10	18	0	15	5	25	15	35	30	55
18	30	0	20	10	30	20	40	40	65
30	50	0	25	10	40	25	55	50	80
50	80	0	30	15	50	30	65	60	100
80	100	0	35	20	55	35	75	70	115

4. Mounting dimensions

If a bearing lacks a function for axially guiding the outer ring, as in the case of the series RNA22 series or NA22 bearings, the shaft must be provided with a flange or thrust washer to guide the outer ring. The guide surface should preferably be hardened, and the guide width should be at least half the outer ring width. At minimum, the guide surface must be finished by a turning process, and must be smooth and free from burrs.

The mounting surface for series NATR, NATV and NUTR rollers must at least adopt dimensions e specified in the associated bearing tables so that their side plates can make full contact.

5. Lubrication

Rollers having a synthetic rubber seal (suffix LL) and those of the full-complement type are pre-filled with lithium soap grease and can operate at a temperature range of 25°C to 100 °C. The internal bearing grease can be replenished through a lubrication hole on the inner ring. The rollers must be installed so that the lubrication hole is located in a non-load zone. The series NATV and NUTR being full-complement types, must be lubricated more frequently than the caged types.

**ROLLER FOLLOWERS YOKE TYPE TRUCK ROLLERS
SERIES NATR**

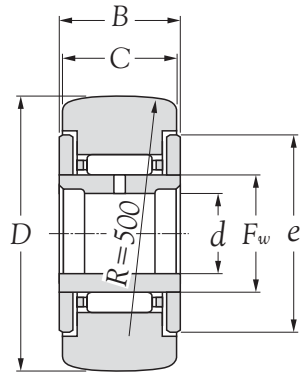

**Type NATR
(With cage)**

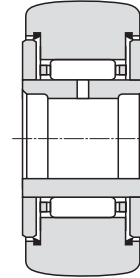

**Type NATR..LL
(Sealed type with cage)**

D _{0 -0.05}	Boundary dimensions					Basic load ratings				Bearing numbers	
	B	mm			F _w	dynamic N	static	dynamic kgf	static		
		C	d	e		C _r	C _{or}	C _r	C _{or}		
16	12 _{0 -0.180}	11	5	12	8.0	3,850	3,950	395	400	NATR 5	NATR 5 LL
19	12 _{0 -0.180}	11	6	14	10.0	4,500	5,100	460	520	NATR 6	NATR 6 LL
24	15 _{0 -0.180}	14	8	19	12.0	6,600	7,300	675	745	NATR 8	NATR 8 LL
30	15 _{0 -0.180}	14	10	23	15.0	7,500	9,100	765	930	NATR 10	NATR 10 LL
32	15 _{0 -0.180}	14	12	25	17.0	8,500	11,100	865	1,130	NATR 12	NATR 12 LL
35	19 _{0 -0.210}	18	15	27	20.0	13,000	20,100	1,320	2,050	NATR 15	NATR 15 LL
40	21 _{0 -0.210}	20	17	32	22.0	13,600	22,100	1,390	2,250	NATR 17	NATR 17 LL
47	25 _{0 -0.210}	24	20	37	25.0	20,300	33,000	2,070	3,350	NATR 20	NATR 20 LL
52	25 _{0 -0.210}	24	25	42	30.0	22,300	39,500	2,280	4,000	NATR 25	NATR 25 LL
62	29 _{0 -0.210}	28	30	51	38.0	35,000	64,000	3,600	6,550	NATR 30	NATR 30 LL
72	29 _{0 -0.210}	28	35	58	44.5	38,000	74,500	3,850	7,600	NATR 35	NATR 35 LL
80	32 _{0 -0.250}	30	40	66	50.0	48,500	90,000	4,950	9,150	NATR 40	NATR 40 LL
85	32 _{0 -0.250}	30	45	71	55.0	50,500	97,500	5,150	9,950	NATR 45	NATR 45 LL
90	32 _{0 -0.250}	30	50	76	60.0	52,000	105,000	5,300	10,700	NATR 50	NATR 50 LL

**ROLLER FOLLOWERS YOKE TYPE TRUCK ROLLERS
SERIES NATR**

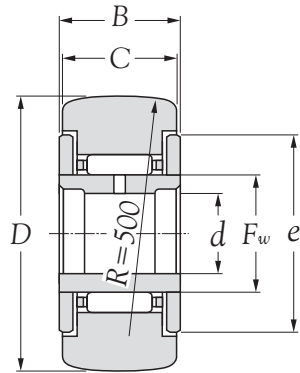

Type NATR
(With cage)

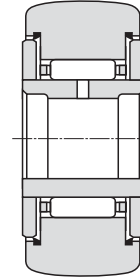

Type NATR..LL
(Sealed type with cage)

Load ratings of truck				Limiting speeds		Bearing numbers		Mass
Spherical outer ring	N Cylindrical outer ring	kgf		rpm		NATR 5	NATR 5 LL	kg (approx.)
		Spherical outer ring	Cylindrical outer ring	grease	oil			
1,080	3,400	110	350	※19,000	※25,000			0.018
1,380	4,050	141	415	※15,000	※20,000	NATR 6	NATR 6 LL	0.025
1,900	6,650	193	680	※12,000	※16,000	NATR 8	NATR 8 LL	0.042
2,620	7,700	267	785	10,000	※13,000	NATR 10	NATR 10 LL	0.061
2,860	8,200	291	835	9,000	※12,000	NATR 12	NATR 12 LL	0.069
3,200	11,900	325	1,220	7,500	10,000	NATR 15	NATR 15 LL	0.098
3,850	14,500	390	1,480	7,000	9,000	NATR 17	NATR 17 LL	0.140
4,700	21,000	480	2,150	6,000	8,000	NATR 20	NATR 20 LL	0.246
5,500	23,300	565	2,370	5,000	6,500	NATR 25	NATR 25 LL	0.275
6,950	33,000	710	3,350	4,000	5,500	NATR 30	NATR 30 LL	0.470
8,050	37,000	820	3,750	3,300	4,500	NATR 35	NATR 35 LL	0.635
9,800	44,500	1,000	4,500	3,000	4,000	NATR 40	NATR 40 LL	0.875
10,400	47,000	1,060	4,800	2,700	3,600	NATR 45	NATR 45 LL	0.910
11,400	50,000	1,160	5,100	2,500	3,300	NATR 50	NATR 50 LL	0.960

Notes: Limiting speed of sealed type bearings marked with ※ is approximately 10 000 rpm.

**ROLLER FOLLOWERS YOKE TYPE TRUCK ROLLERS
SERIES NATV**

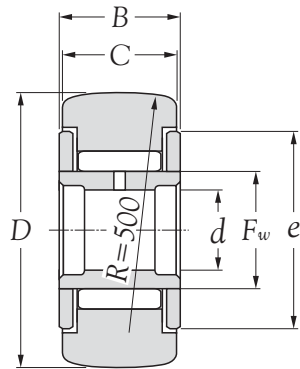

Type NATV
(Full complement type)

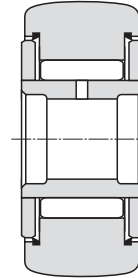

Type NATV.LL
(Full complement type with seals)

Boundary dimensions						Basic load ratings				Bearing numbers		
D ⁰ / _{-0.05}	B	mm				F _w	dynamic	static	dynamic	static		
		C	d	e	N		kgf	kgf				
						C _r	C _{or}	C _r	C _{or}			
16	12 ⁰ / _{-0.180}	11	5	12	8.0	6,250	8,900	640	910	NATV 5	NATV 5 LL	
19	12 ⁰ / _{-0.180}	11	6	14	10.0	7,200	11,200	735	1,140	NATV 6	NATV 6 LL	
24	15 ⁰ / _{-0.180}	14	8	19	12.0	10,300	15,500	1,050	1,580	NATV 8	NATV 8 LL	
30	15 ⁰ / _{-0.180}	14	10	23	15.0	11,700	19,500	1,190	1,980	NATV 10	NATV 10 LL	
32	15 ⁰ / _{-0.180}	14	12	25	17.0	12,600	22,100	1,280	2,250	NATV 12	NATV 12 LL	
35	19 ⁰ / _{-0.210}	18	15	27	20.0	18,000	37,000	1,830	3,750	NATV 15	NATV 15 LL	
40	21 ⁰ / _{-0.210}	20	17	32	22.0	18,900	40,500	1,930	4,150	NATV 17	NATV 17 LL	
47	25 ⁰ / _{-0.210}	24	20	37	25.0	28,400	60,000	2,900	6,100	NATV 20	NATV 20 LL	
52	25 ⁰ / _{-0.210}	24	25	42	30.0	31,000	72,000	3,150	7,350	NATV 25	NATV 25 LL	
62	29 ⁰ / _{-0.210}	28	30	51	38.0	46,500	112,000	4,750	11,400	NATV 30	NATV 30 LL	
72	29 ⁰ / _{-0.210}	28	35	58	44.5	51,000	130,000	5,200	13,300	NATV 35	NATV 35 LL	
80	32 ⁰ / _{-0.250}	30	40	66	50.0	67,500	167,000	6,850	17,100	NATV 40	NATV 40 LL	
90	32 ⁰ / _{-0.250}	30	50	76	60.0	74,500	200,000	7,600	20,400	NATV 50	NATV 50 LL	

**ROLLER FOLLOWERS YOKE TYPE TRUCK ROLLERS
SERIES NATV**

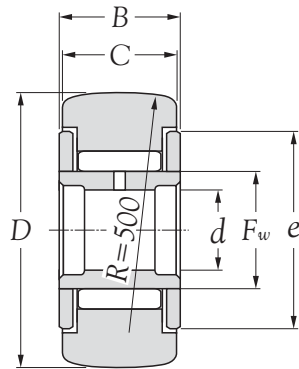

Type NATV
(Full complement type)

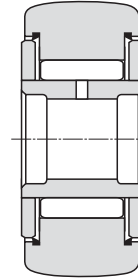

Type NATV.LL
(Full complement type with seals)

Load ratings of truck				Limiting speeds		Bearing numbers		Mass
Spherical outer ring	N Cylindrical outer ring	kgf		rpm		NATV 5	NATV 5 LL	kg (approx.)
		Spherical outer ring	Cylindrical outer ring	grease	oil			
1,080	3,400	110	350	※13,000	※16,000	NATV 5	NATV 5 LL	0.020
1,380	4,050	141	415	10,000	※13,000	NATV 6	NATV 6 LL	0.027
1,900	6,650	193	680	8,500	※11,000	NATV 8	NATV 8 LL	0.044
2,620	7,700	267	785	6,500	8,500	NATV 10	NATV 10 LL	0.065
2,860	8,200	291	835	6,000	7,500	NATV 12	NATV 12 LL	0.074
3,200	11,900	325	1,220	5,000	6,500	NATV 15	NATV 15 LL	0.102
3,850	14,500	390	1,480	4,500	6,000	NATV 17	NATV 17 LL	0.145
4,700	21,000	480	2,150	4,000	5,000	NATV 20	NATV 20 LL	0.254
5,500	23,300	565	2,370	3,300	4,500	NATV 25	NATV 25 LL	0.285
6,950	33,000	710	3,350	2,600	3,500	NATV 30	NATV 30 LL	0.481
8,050	37,000	820	3,750	2,200	2,900	NATV 35	NATV 35 LL	0.647
9,800	44,500	1,000	4,500	2,000	2,600	NATV 40	NATV 40 LL	0.890
11,400	50,000	1,160	5,100	1,600	2,100	NATV 50	NATV 50 LL	0.990

Notes: Limiting speed of sealed type bearings marked with ※ is approximately 10 000 rpm.

**ROLLER FOLLOWERS YOKE TYPE TRUCK ROLLERS
SERIES NUTR**

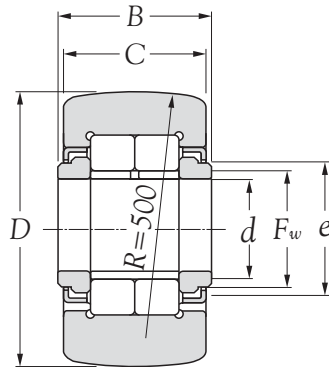

Boundary dimensions							Basic load ratings				Bearing numbers	
D 0 -0.05	B	mm		d	e	F_w	$r_s \text{ min}^{1)}$	dynamic N	static	dynamic kgf		static
		C	d	e	F_w	$r_s \text{ min}^{1)}$		C_r	C_{or}	C_r	C_{or}	
35	19 0 -0.210	18	15	20	19.0	0.3		22,300	25,700	2,280	2,620	NUTR 202
40	21 0 -0.210	20	17	22	21.5	0.3		24,100	29,100	2,450	2,970	NUTR 203
42	19 0 -0.210	18	15	20	19.0	0.3		22,300	25,700	2,280	2,620	NUTR 302
47	21 0 -0.210	20	17	22	21.5	0.3		24,100	29,100	2,450	2,970	NUTR 303
47	25 0 -0.210	24	20	27	25.5	0.3		38,500	48,000	3,950	4,900	NUTR 204
52	25 0 -0.210	24	20	27	25.5	0.3		38,500	48,000	3,950	4,900	NUTR 304
52	25 0 -0.210	24	25	31	30.0	0.3		42,500	57,500	4,350	5,850	NUTR 205
62	25 0 -0.210	24	25	31	30.0	0.3		42,500	57,500	4,350	5,850	NUTR 305
62	29 0 -0.210	28	30	38	35.0	0.3		56,500	72,500	5,750	7,400	NUTR 206
72	29 0 -0.210	28	30	38	35.0	0.3		56,500	72,500	5,750	7,400	NUTR 306
72	29 0 -0.210	28	35	44	41.5	0.6		62,000	85,500	6,350	8,700	NUTR 207
80	29 0 -0.210	28	35	44	41.5	0.6		62,000	85,500	6,350	8,700	NUTR 307
80	32 0 -0.250	30	40	51	47.5	0.6		87,000	125,000	8,850	12,700	NUTR 208
85	32 0 -0.250	30	45	55	52.5	0.6		92,000	137,000	9,350	14,000	NUTR 209
90	32 0 -0.250	30	40	51	47.5	0.6		87,000	125,000	8,850	12,700	NUTR 308
90	32 0 -0.250	30	50	60	57.0	0.6		96,500	150,000	9,800	15,300	NUTR 210
100	32 0 -0.250	30	45	55	52.5	0.6		92,000	137,000	9,350	14,000	NUTR 309
110	32 0 -0.250	30	50	60	57.0	0.6		96,500	150,000	9,800	15,300	NUTR 310

Notes: 1) These values are the allowable minimum dimensions of the chamfer dimension r .

**ROLLER FOLLOWERS YOKE TYPE TRUCK ROLLERS
SERIES NUTR**

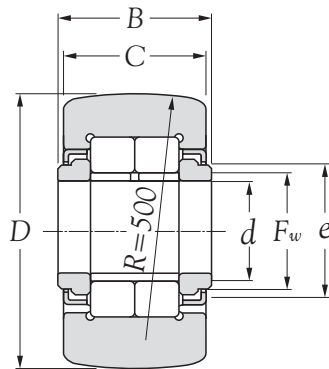

Load ratings of truck		Limiting speeds		Bearing numbers	Mass kg (approx.)
N	kgf	rpm	rpm		
Spherical outer ring	Cylindrical outer ring	Spherical outer ring	Cylindrical outer ring		
3,200	11,900	325	1,220	grease	NUTR 202 0.100
3,850	14,500	390	1,480	5,500	NUTR 203 0.147
4,100	14,300	415	1,460	4,700	NUTR 302 0.160
4,700	17,000	480	1,740	4,000	NUTR 303 0.222
4,700	21,000	480	2,150	3,300	NUTR 204 0.245
5,550	23,300	565	2,370	2,900	NUTR 304 0.321
5,550	23,300	565	2,370	2,400	NUTR 205 0.281
6,950	27,800	710	2,830	2,100	NUTR 305 0.450
6,950	33,000	710	3,350	1,900	NUTR 206 0.466
8,050	38,500	820	3,900	1,800	NUTR 306 0.697
8,050	37,000	820	3,750	1,900	NUTR 207 0.630
9,800	41,000	1,000	4,150	1,800	NUTR 307 0.840
9,800	44,500	1,000	4,500	1,800	NUTR 208 0.817
10,400	47,000	1,060	4,800	1,900	NUTR 209 0.883
11,400	50,000	1,160	5,100	2,100	NUTR 308 1.130
11,400	50,000	1,160	5,100	1,800	NUTR 210 0.950
13,000	55,500	1,330	5,650	1,900	NUTR 309 1.400
14,700	61,000	1,500	6,200	1,800	NUTR 310 1.690

**ROLLER FOLLOWERS YOKE TYPE TRUCK ROLLERS SEALED TYPE
SERIES NA22..LL, RNA22..LL**

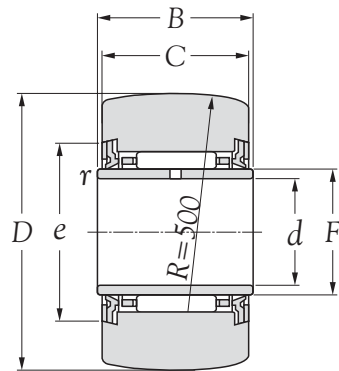

**Type NA22..LL
(With inner ring)**

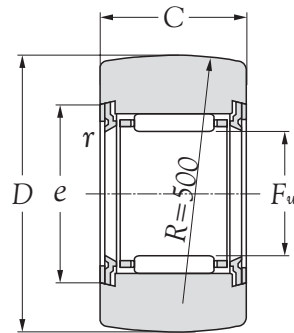

**Type RNA22..LL
(Without inner ring)**

Boundary dimensions								Basic load ratings				Bearing numbers	
D 0 -0.05	B	C	mm		e	F	r s min ¹⁾	dynamic	static	dynamic	static		
			N	N				kgf	kgf				
19	12	11.8	6	10 ^{+0.022 +0.013}	16	10	0.3	4,300	3,950	435	405	NA 22/6 LL	RNA 22/6 LL
24	12	11.8	8	12 ^{+0.027 +0.016}	18	12	0.3	4,850	4,900	495	500	NA 22/8 LL	RNA 22/8 LL
30	14	13.8	10	14 ^{+0.027 +0.016}	20	14	0.3	7,200	8,500	735	865	NA 2200 LL	RNA 2200 LL
32	14	13.8	12	16 ^{+0.027 +0.016}	22	16	0.3	7,750	9,700	795	990	NA 2201 LL	RNA 2201 LL
35	14	13.8	15	20 ^{+0.033 +0.020}	26	20	0.3	9,500	13,400	970	1,370	NA 2202 LL	RNA 2202 LL
40	16	15.8	17	22 ^{+0.033 +0.020}	28	22	0.3	10,100	14,900	1,030	1,520	NA 2203 LL	RNA 2203 LL
47	18	17.8	20	25 ^{+0.033 +0.020}	33	25	0.3	16,500	22,100	1,680	2,250	NA 2204 LL	RNA 2204 LL
52	18	17.8	25	30 ^{+0.033 +0.020}	38	30	0.3	17,400	25,000	1,770	2,550	NA 2205 LL	RNA 2205 LL
62	20	19.8	30	35 ^{+0.041 +0.025}	43	35	0.3	20,900	33,500	2,130	3,400	NA 2206 LL	RNA 2206 LL
72	23	22.7	35	42 ^{+0.041 +0.025}	50	42	0.6	25,700	46,000	2,630	4,700	NA 2207 LL	RNA 2207 LL
80	23	22.7	40	48 ^{+0.041 +0.025}	57	48	0.6	27,800	53,500	2,830	5,450	NA 2208 LL	RNA 2208 LL
85	23	22.7	45	52 ^{+0.049 +0.030}	62	52	0.6	28,600	57,000	2,920	5,800	NA 2209 LL	RNA 2209 LL
90	23	22.7	50	58 ^{+0.049 +0.030}	68	58	0.6	30,500	64,000	3,100	6,500	NA 2210 LL	RNA 2210 LL

Notes: 1) These values are the allowable minimum dimensions of the chamfer dimension r.

**ROLLER FOLLOWERS YOKE TYPE TRUCK ROLLERS SEALED TYPE
SERIES NA22..LL, RNA22..LL**

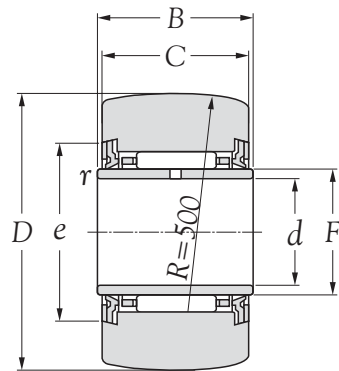

**Type NA22..LL
(With inner ring)**

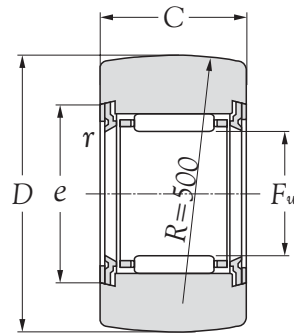

**Type RNA22..LL
(Without inner ring)**

Load ratings of truck				Limiting speeds rpm grease	Bearing numbers		Mass kg (approx.)	
N		Kgf			NA 22/6 LL	RNA 22/6 LL	Type NA22..LL	Type RNA22..LL
Spherical outer ring	Cylindrical outer ring	Spherical outer ring	Cylindrical outer ring					
1,380	4,400	141	445	10,000	NA 22/6 LL	RNA 22/6 LL	0.023	0.018
1,900	5,500	193	565	10,000	NA 22/8 LL	RNA 22/8 LL	0.035	0.027
2,620	7,550	267	770	10,000	NA 2200 LL	RNA 2200 LL	0.060	0.052
2,860	8,050	291	820	9,500	NA 2201 LL	RNA 2201 LL	0.067	0.057
3,200	8,800	325	900	7,500	NA 2202 LL	RNA 2202 LL	0.075	0.060
3,850	10,900	390	1,110	7,000	NA 2203 LL	RNA 2203 LL	0.113	0.094
4,700	14,800	480	1,510	6,000	NA 2204 LL	RNA 2204 LL	0.176	0.152
5,550	16,400	565	1,670	5,000	NA 2205 LL	RNA 2205 LL	0.209	0.179
6,950	22,200	710	2,260	4,300	NA 2206 LL	RNA 2206 LL	0.322	0.284
8,050	28,700	820	2,930	3,600	NA 2207 LL	RNA 2207 LL	0.506	0.432
9,800	32,000	1,000	3,250	3,100	NA 2208 LL	RNA 2208 LL	0.623	0.530
10,400	34,000	1,060	3,450	2,900	NA 2209 LL	RNA 2209 LL	0.638	0.545
11,400	36,000	1,160	3,650	2,600	NA 2210 LL	RNA 2210 LL	0.682	0.563

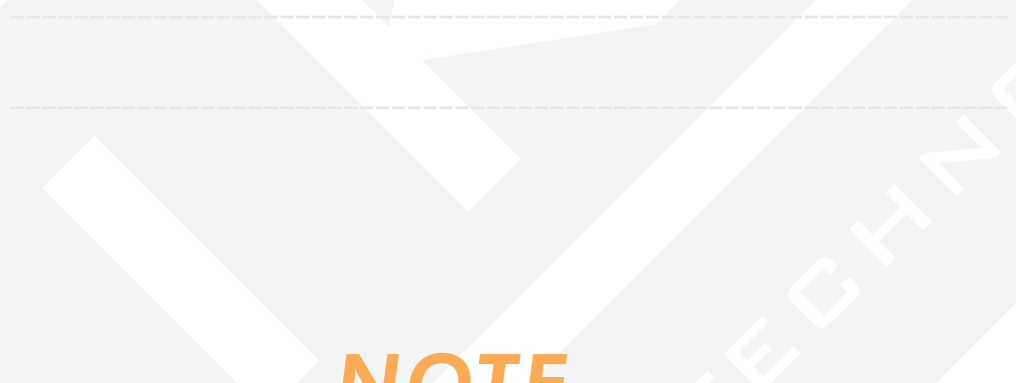

NOTE

AUTOMATION TECHNOLOGY



CAM FOLLOWERS

1. Types and designs

NIKO Stud-type Track Rollers are available in three basic series: the series KR, whose rolling elements are needle rollers retained and guided by a cage; the full-complement series KRV lacking a cage, whose rolling elements are needle rollers; and the series NUKR, a full-complement type whose rolling elements are double-row cylindrical rollers. The cage of the stud-type track rollers is pressed steel. However, cages of molded polyamide reinforced with glass fiber or carbon fiber (suffix T2) may be used. The T2 cage features a maximum allowable operating temperature of 120°C and a maximum allowable continuous operating temperature of 100°C. The series KR is suitable for high-speed applications because the cage guides the needle rollers. Compared with a full-complement configuration, this bearing's larger internal volume holds a larger amount of grease, which contributes to relatively extended relubrication intervals. Also available is a variant (suffix LL) with a synthetic rubber seal located between the outer ring, flange, and side plate.

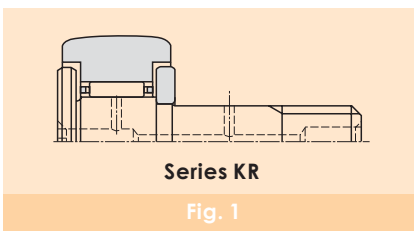

Compared with the series KR, the track roller series KRV has more needle rollers and therefore is suitable for heavy load applications, but it has a lower limiting speed. A variant (suffix LL) with a seal is also available. Because this bearing holds less grease, the relubrication intervals for this type are shorter.

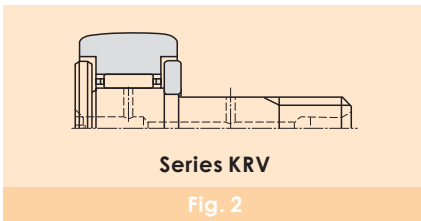

Compared with full-complement needle roller bearings, the series NUKR track rollers can carry a greater load and are therefore suitable for applications involving heavy load and impact load, as they are full-complement types using double-row cylindrical rollers as rolling elements. They are guided in the axial direction by the outer ring rib and end faces of cylindrical rollers, and can carry some axial load. Although they are a full-complement configuration, their limiting speed is greater than that of series KRV rollers. Their outer ring incorporates a press-fit steel plate to form a labyrinth between the flange and the outer surface of the side plate. Because there is limited space available for adding grease to the bearing, the bearing must be relubricated more frequently.

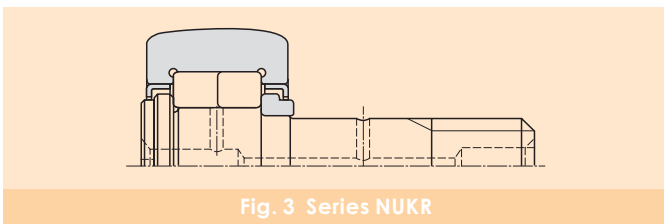

2. Interpreting bearing numbers

The bearing numbers of **NIKO** Stud-type Track Rollers comprise a series number, dimension code (outside diameter), and suffix.

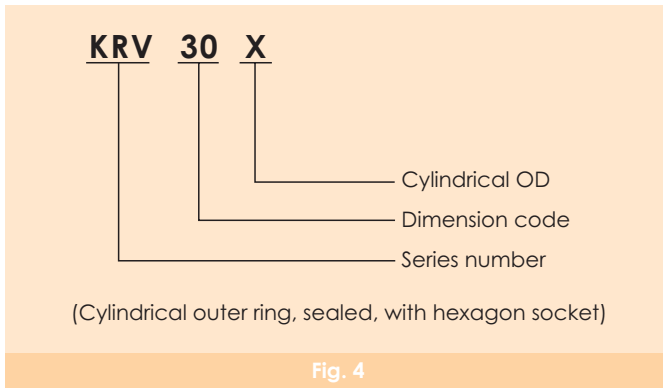
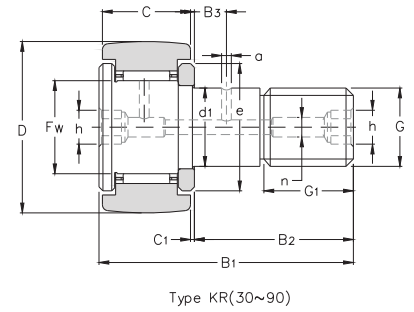
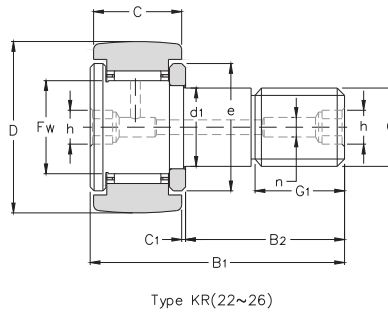
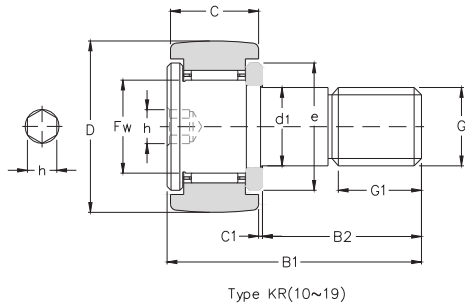

Fig. 4

3. Lubrication

The rollers having a synthetic rubber seal (suffix LL) as well as the full-complement type are pre-filled with lithium soap grease and can operate at a temperature range of -25°C to 100°C. The inside of the bearing can be refilled through a grease nipple installed on the bearing-side end face (flange end face) or threaded end face of the stud. Any lubrication hole not used for relubrication must be plugged. The necessary grease nipple and plug are included in the package and must be installed on the roller before the cam follower is mounted.

CAM FOLLOWERS STUD TYPE TRUCK ROLLERS
SERIES KR



Boundary dimensions													Bearing numbers	
D	C	d1	Fw	B1	B2	mm G	G1	C1	n	B3	a	e		h
$10_{-0.050}^0$	7	$3_{-0.010}^0$	4.00	17	9.0	M 3 X 0.5	5.0	0.5	-	-	-	7.0	2.5 ³⁾	KR 10
12	8	$4_{-0.012}^0$	4.80	20	11.0	M 4 X 0.7	6.0	0.5	-	-	-	8.5	2.5 ³⁾	KR 12
13	9	$5_{-0.012}^0$	5.75	23	13.0	M 5 X 0.8	7.5	0.5	-	-	-	9.5	3 ³⁾	KR 13
16	11	$6_{-0.012}^0$	8.00	28	16.0	M 6 X 1.0	8.0	0.6	4 ²⁾	-	-	12.0	4	KR 16
19	11	$8_{-0.015}^0$	10.00	32	20.0	M 8 X 1.25	10.0	0.6	4 ²⁾	-	-	14.0	4	KR 19
22	12	$10_{-0.015}^0$	12.00	36	23.0	M 10 X 1.0	12.0	0.6	4	-	-	17.0	5	KR 22
26	12	$10_{-0.015}^0$	12.00	36	23.0	M 10 X 1.0	12.0	0.6	4	-	-	17.0	5	KR 26
30	14	$12_{-0.018}^0$	15.00	40	25.0	M 12 X 1.5	13.0	0.6	6	6	3	23.0	6	KR 30
32	14	$12_{-0.018}^0$	15.00	40	25.0	M 12 X 1.5	13.0	0.6	6	6	3	23.0	6	KR 32
35	18	$16_{-0.018}^0$	18.00	52	32.5	M 16 X 1.5	17.0	0.8	6	8	3	27.0	8	KR 35
40	20	$18_{-0.018}^0$	22.00	58	36.5	M 18 X 1.5	19.0	0.8	6	8	3	32.0	8	KR 40
47	24	$20_{-0.021}^0$	25.00	66	40.5	M 20 X 1.5	21.0	0.8	8	9	4	37.0	10	KR 47
52	24	$20_{-0.021}^0$	25.00	66	40.5	M 20 X 1.5	21.0	0.8	8	9	4	37.0	10	KR 52
62	29	$24_{-0.021}^0$	30.00	80	49.5	M 24 X 1.5	25.0	0.8	8	11	4	44.0	14	KR 62
72	29	$24_{-0.021}^0$	30.00	80	49.5	M 24 X 1.5	25.0	0.8	8	11	4	44.0	14	KR 72
80	35	$30_{-0.021}^0$	38.00	100	63.0	M 30 X 1.5	32.0	1.0	8	15	4	53.0	14	KR 80
90	35	$30_{-0.021}^0$	38.00	100	63.0	M 30 X 1.5	32.0	1.0	8	15	4	53.0	14	KR 90

CAM FOLLOWERS STUD TYPE TRUCK ROLLERS
SERIES KR

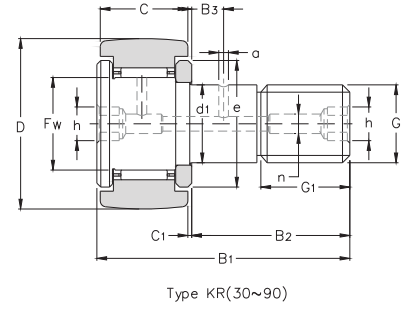
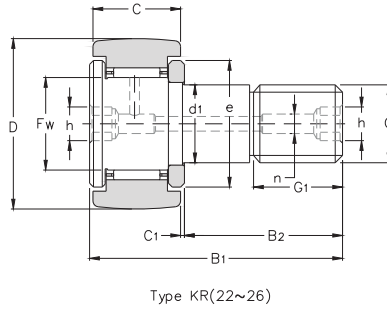
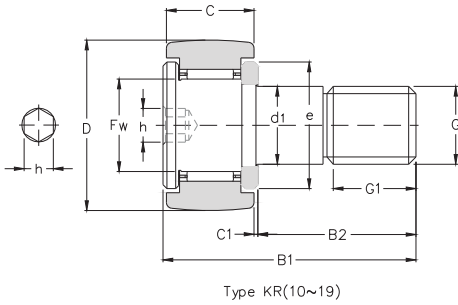

Basic load ratings				Load ratings of truck				Limiting speeds		Maximum tightening torque		Bearing numbers	Mass kg (approx.)	Stud diameter mm
dynamic N	static Cor	dynamic Cr	static Cor	N		kgf		rpm		N.m	Kgf.m			
Cr	Cor	Cr	Cor	Spherical outer ring	Cylindrical outer ring	Spherical outer ring	Cylindrical outer ring	grease	oil					
1,510	1,140	154	116	560	1,360	57	139	※27,000	※40,000	0.5	0.05	KR 10	0.005	3
2,030	1,550	207	159	725	1,790	74	183	※25,000	※36,000	1.0	0.10	KR 12	0.008	4
2,480	2,070	253	211	805	2,220	82	226	※23,000	※33,000	2.0	0.20	KR 13	0.010	5
3,850	3,950	395	400	1,080	3,400	110	350	※19,000	※25,000	3.0	0.30	KR 16	0.019	6
4,500	5,100	460	520	1,380	4,050	141	415	※15,000	※20,000	8.0	0.80	KR 19	0.031	8
5,050	6,250	515	635	1,690	5,150	172	525	※12,000	※16,000	15.0	1.50	KR 22	0.046	10
5,050	6,250	515	635	2,120	6,100	216	620	※12,000	※16,000	15.0	1.50	KR 26	0.059	10
7,500	9,100	765	930	2,620	7,700	267	785	10,000	※13,000	22.0	2.20	KR 30	0.087	12
7,500	9,100	765	930	2,860	8,200	291	835	10,000	※13,000	22.0	2.20	KR 32	0.097	12
11,800	17,300	1,210	1,760	3,200	11,900	325	1,220	8,000	※11,000	58.0	5.80	KR 35	0.169	16
13,600	22,100	1,390	2,250	3,850	14,500	390	1,480	7,000	9,000	87.0	8.70	KR 40	0.248	18
20,300	33,000	2,070	3,350	4,700	21,000	480	2,150	6,000	8,000	120.0	12.00	KR 47	0.386	20
20,300	33,000	2,070	3,350	5,550	23,300	565	2,370	6,000	8,000	120.0	12.00	KR 52	0.461	20
29,100	55,000	2,960	5,650	6,950	34,500	710	3,500	5,000	6,500	220.0	22.00	KR 62	0.790	24
29,100	55,000	2,960	5,650	8,050	38,500	820	3,900	5,000	6,500	220.0	22.00	KR 72	1.040	24
44,000	86,500	4,500	8,800	9,800	53,000	1,000	5,400	4,000	5,500	450.0	45.00	KR 80	1.550	30
44,000	86,500	4,500	8,800	11,400	59,000	1,160	6,100	4,000	5,500	450.0	45.00	KR 90	1.950	30

Notes: Limiting speed of sealed type bearings marked with ※ is approximately 10 000 rpm.

CAM FOLLOWERS STUD TYPE TRUCK ROLLERS
SERIES KRV

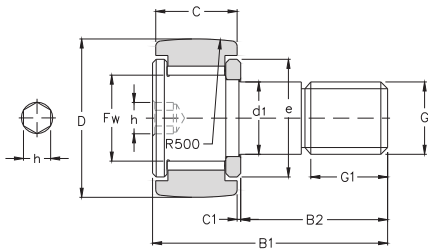

Type KRV(10~19)

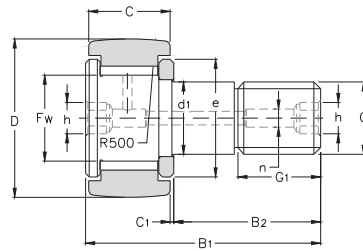

Type KRV(22~26)

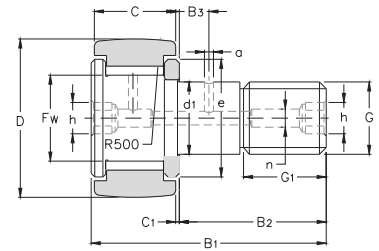

Type KRV(30~90)

Boundary dimensions														Bearing numbers
mm														
D 0 -0.050	C	d1	Fw	B1	B2	G	G1	C1	n	B3	a	e	h	
10	7	3 ⁰ _{-0.010}	4.00	17	9.0	M 3 X 0.5	5.0	0.5	-	-	-	7.0	2.5 ³⁾	KRV 10
12	8	4 ⁰ _{-0.012}	4.80	20	11.0	M 4 X 0.7	6.0	0.5	-	-	-	8.5	2.5 ³⁾	KRV 12
13	9	5 ⁰ _{-0.012}	5.75	23	13.0	M 5 X 0.8	7.5	0.5	-	-	-	9.5	3 ³⁾	KRV 13
16	11	6 ⁰ _{-0.012}	8.00	28	16.0	M 6 X 1.0	8.0	0.6	4 ²⁾	-	-	12.0	3	KRV 16
19	11	8 ⁰ _{-0.015}	10.00	32	20.0	M 8 X 1.25	10.0	0.6	4 ²⁾	-	-	14.0	4	KRV 19
22	12	10 ⁰ _{-0.015}	12.00	36	23.0	M 10 X 1.0	12.0	0.6	4	-	-	17.0	5	KRV 22
26	12	10 ⁰ _{-0.015}	12.00	36	23.0	M 10 X 1.0	12.0	0.6	4	-	-	17.0	5	KRV 26
30	14	12 ⁰ _{-0.018}	15.00	40	25.0	M 12 X 1.5	13.0	0.6	6	6	3	23.0	6	KRV 30
32	14	12 ⁰ _{-0.018}	15.00	40	25.0	M 12 X 1.5	13.0	0.6	6	6	3	23.0	6	KRV 32
35	18	16 ⁰ _{-0.018}	18.00	52	32.5	M 16 X 1.5	17.0	0.8	6	8	3	27.0	8	KRV 35
40	20	18 ⁰ _{-0.018}	22.00	58	36.5	M 18 X 1.5	19.0	0.8	6	8	3	32.0	8	KRV 40
47	24	20 ⁰ _{-0.021}	25.00	66	40.5	M 20 X 1.5	21.0	0.8	8	9	4	37.0	10	KRV 47
52	24	20 ⁰ _{-0.021}	25.00	66	40.5	M 20 X 1.5	21.0	0.8	8	9	4	37.0	10	KRV 52
62	29	24 ⁰ _{-0.021}	30.00	80	49.5	M 24 X 1.5	25.0	0.8	8	11	4	44.0	14	KRV 62
72	29	24 ⁰ _{-0.021}	30.00	80	49.5	M 24 X 1.5	25.0	0.8	8	11	4	44.0	14	KRV 72
80	35	30 ⁰ _{-0.021}	38.00	100	63.0	M 30 X 1.5	32.0	1.0	8	15	4	53.0	14	KRV 80
90	35	30 ⁰ _{-0.021}	38.00	100	63.0	M 30 X 1.5	32.0	1.0	8	15	4	53.0	14	KRV 90

CAM FOLLOWERS STUD TYPE TRUCK ROLLERS
SERIES KRV

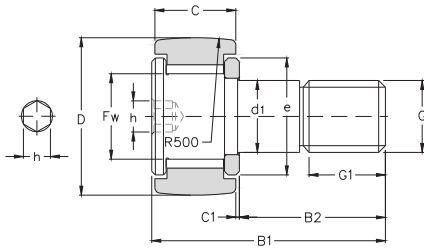

Type KRV(10~19)

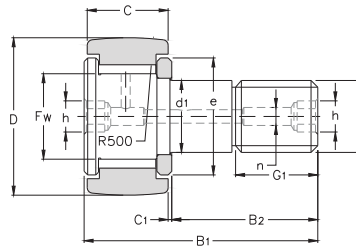

Type KRV(22~26)

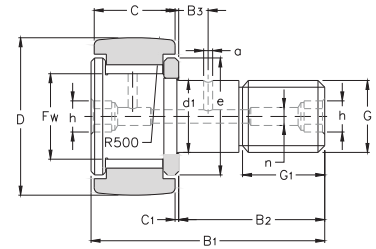

Type KRV(30~90)

Basic load ratings				Load ratings of truck				Limiting speeds		Maximum tightening torque		Bearing numbers	Mass kg (approx.)	Stud diameter mm
dynamic N	static Cor	dynamic kgf	static Cor	N		kgf		rpm		N.m	Kgf.m			
Cr	Cor	Cr	Cor	Spherical outer ring	Cylindrical outer ring	Spherical outer ring	Cylindrical outer ring	grease	oil					
2,330	2,400	238	244	560	1,360	57	139	※25,000	※32,000	0.5	0.05	KRV 10	0.005	3
3,350	3,550	340	360	725	1,790	74	183	※20,000	※27,000	1.0	0.10	KRV 12	0.008	4
4,300	5,050	435	510	805	2,220	82	226	※17,000	※22,000	2.0	0.20	KRV 13	0.011	5
6,250	8,900	640	910	1,080	3,400	110	350	※13,000	※16,000	3.0	0.30	KRV 16	0.020	6
7,200	11,200	735	1,140	1,380	4,050	141	415	10,000	※13,000	8.0	0.80	KRV 19	0.032	8
7,900	13,300	810	1,360	1,690	5,150	172	525	8,500	※11,000	15.0	1.50	KRV 22	0.047	10
7,900	13,300	810	1,360	2,120	6,100	216	620	8,500	※11,000	15.0	1.50	KRV 26	0.061	10
11,700	19,500	1,190	1,980	2,620	7,700	267	785	6,500	8,500	22.0	2.20	KRV 30	0.089	12
11,700	19,500	1,190	1,980	2,860	8,200	291	835	6,500	8,500	22.0	2.20	KRV 32	0.100	12
17,200	33,000	1,750	3,400	3,200	11,900	325	1,220	5,500	7,000	58.0	5.80	KRV 35	0.172	16
18,900	40,500	1,930	4,150	3,850	14,500	390	1,480	4,500	6,000	87.0	8.70	KRV 40	0.252	18
28,300	60,000	2,890	6,100	4,700	21,000	480	2,150	4,000	5,000	120.0	12.00	KRV 47	0.390	20
28,300	60,000	2,890	6,100	5,550	23,300	565	2,370	4,000	5,000	120.0	12.00	KRV 52	0.465	20
39,000	96,500	3,950	9,850	6,950	34,500	710	3,500	3,300	4,500	220.0	22.00	KRV 62	0.800	24
39,000	96,500	3,950	9,850	8,050	38,500	820	3,900	3,300	4,500	220.0	22.00	KRV 72	1.050	24
57,000	144,000	5,800	14,700	9,800	53,000	1,000	5,400	2,600	3,500	450.0	45.00	KRV 80	1.560	30
57,000	144,000	5,800	14,700	11,400	59,000	1,160	6,100	2,600	3,500	450.0	45.00	KRV 90	1.970	30

Notes: Limiting speed of sealed type bearings marked with ※ is approximately 10 000 rpm.

CAM FOLLOWERS STUD TYPE TRUCK ROLLERS (MULTI-ROW CYLINDRICAL ROLLER BEARINGS)
SERIES NUKR

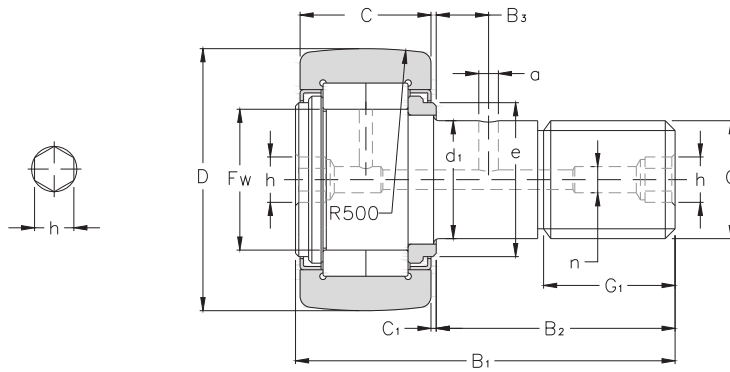

Type NUKR(D<100mm)
 (Double row type full complement with seal)

Boundary dimensions															Bearing numbers
mm															
D ₀ ⁰ _{-0.050}	C	d ₁	F _w	B ₁	B ₂	G	G ₁	C ₁	n	m	B ₃	a	e	h	
35	18	16 ⁰ _{-0.018}	19.0	52	32.5	M 16 X 1.5	17	0.8	6	-	8	3	21	8	NUKR 35
40	20	18 ⁰ _{-0.018}	21.5	58	36.5	M 18 X 1.5	19	0.8	6	-	8	3	23	8	NUKR 40
47	24	20 ⁰ _{-0.021}	25.5	66	40.5	M 20 X 1.5	21	0.8	8	-	9	4	27	10	NUKR 47
52	24	20 ⁰ _{-0.021}	30.0	66	40.5	M 20 X 1.5	21	0.8	8	-	9	4	31	10	NUKR 52
62	29	24 ⁰ _{-0.021}	35.0	80	49.5	M 24 X 1.5	25	0.8	8	-	11	4	38	14	NUKR 62
72	29	24 ⁰ _{-0.021}	41.5	80	49.5	M 24 X 1.5	25	0.8	8	-	11	4	44	14	NUKR 72
80	35	30 ⁰ _{-0.021}	47.5	100	63.0	M 30 X 1.5	32	1.0	8	-	15	4	51	14	NUKR 80
90	35	30 ⁰ _{-0.021}	47.5	100	63.0	M 30 X 1.5	32	1.0	8	-	15	4	51	14	NUKR 90

CAM FOLLOWERS STUD TYPE TRUCK ROLLERS (MULTI-ROW CYLINDRICAL ROLLER BEARINGS)
SERIES NUKR

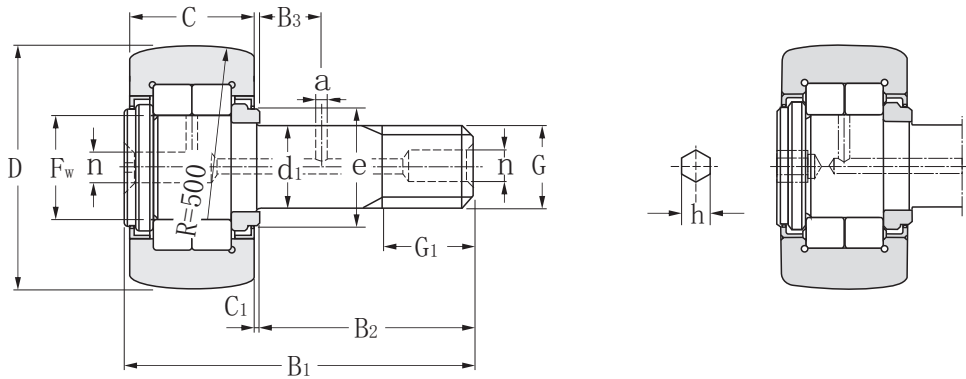

Type NUKR (D<100mm) (double row type full complement with seal)

Basic load ratings				Load ratings of truck				Limiting speeds rpm	Maximum tightening torque		Bearing numbers	Mass kg (approx.)	Stud diameter mm
dynamic N	static Cor	dynamic kgf	static Cor	N		kgf			N.m	Kgf.m			
Cr	Cor	Cr	Cor	Spherical outer ring	Cylindrical outer ring	Spherical outer ring	Cylindrical outer ring	grease					
22,300	25,700	2,280	2,620	3,200	11,900	325	1,220	5,500	58	5.8	NUKR 35	0.165	16
24,100	29,100	2,450	2,970	3,850	14,500	390	1,480	4,700	87	8.7	NUKR 40	0.242	18
38,500	48,000	3,950	4,900	4,700	21,000	480	2,150	4,000	120	12.0	NUKR 47	0.380	20
42,500	57,500	4,350	5,850	5,550	23,300	565	2,370	3,300	120	12.0	NUKR 52	0.450	20
56,500	72,500	5,750	7,400	6,950	34,500	710	3,500	2,900	220	22.0	NUKR 62	0.795	24
62,000	85,500	6,350	8,700	8,050	38,500	820	3,900	2,400	220	22.0	NUKR 72	1.010	24
101,000	151,000	10,300	15,400	9,800	53,000	1,000	5,400	2,100	450	45.0	NUKR 80	1.540	30
101,000	151,000	10,300	15,400	11,400	59,000	1,160	6,100	2,100	450	45.0	NUKR 90	1.960	30



NOTE

AUTOMATION TECHNOLOGY



COMPONENTS

1. Types and designs

NIKO Inner Rings are available in the series IR, whose boundary dimensions are in metric measurements. Both ends of the inner ring are lead-chamfered for easier assembly. Inner rings marked with an asterisk have a slight chamfer in order to provide greater axial displacement. **NIKO** also offers inner rings having a lubrication hole at their midpoint (suffix *D*). For much greater running accuracy, the raceway of the inner ring can be finish-ground after the inner ring has been mounted to a shaft. To accommodate this need, **NIKO** can supply an inner ring whose raceway surface allows for grinding. For details, contact **NIKO** Engineering.

2. Interpreting inner ring numbers

The inner ring numbers of **NIKO** Inner Rings comprise of a series number (IR), dimension code (inside dia. (*d*) × raceway dia. (*F*) × width (*B*), and a suffix.

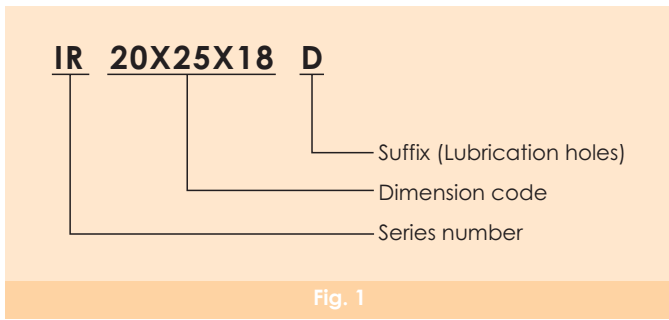
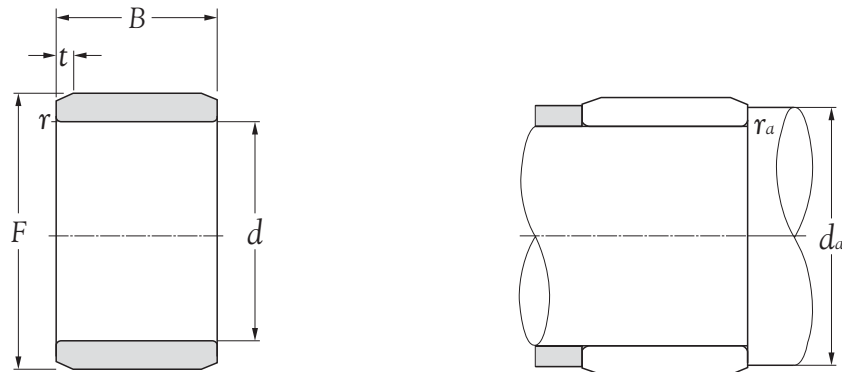

Fig. 1

INNER RINGS
SERIES IR



Boundary dimensions					Bearing numbers	Abutment dimensions		Mass kg (approx.)
mm						mm		
<i>d</i>	<i>F</i> ¹⁾	<i>B</i>	<i>r</i> <small>min²⁾</small>	<i>t</i>		<i>d_a</i> <small>min</small>	<i>r_a</i> <small>max</small>	
5	7 ⁰ _{-0.006}	10.0	0.15	1	IR 5X7X10	6.2	0.15	0.0014
5	8 ⁰ _{-0.006}	12.0	0.30	1	IR 5X8X12	7.0	0.30	0.0028
5	8 ⁰ _{-0.006}	16.0	0.30	-	IR 5X8X16	7.0	0.30	0.0038
6	8 ⁰ _{-0.006}	10.0	0.15	1	IR 6X8X10	7.2	0.15	0.0017
6	9 ⁰ _{-0.006}	12.0	0.30	1	IR 6X9X12	8.0	0.30	0.0032
6	9 ⁰ _{-0.006}	16.0	0.30	1	IR 6X9X16	8.0	0.30	0.0043
6	10 ⁰ _{-0.006}	10.0	0.30	1	IR 6X10X10	8.0	0.30	0.0037
6	10 ⁰ _{-0.006}	12.0	0.30	-	IR 6X10X12	8.0	0.30	0.0046
6	10 ⁰ _{-0.006}	13.0	0.30	1	IR 6X10X13	8.0	0.30	0.0050
7	9 ⁰ _{-0.006}	10.0	0.15	1	IR 7X9X10	8.2	0.15	0.0019
7	10 ⁰ _{-0.006}	10.5	0.30	1	IR 7X10X10.5	9.0	0.30	0.0031
7	10 ⁰ _{-0.006}	12.0	0.30	1	IR 7X10X12	9.0	0.30	0.0036
7	10 ⁰ _{-0.006}	16.0	0.30	1	IR 7X10X16	9.0	0.30	0.0049
7	12 ⁰ _{-0.008}	16.0	0.30	1	IR 7X12X16	9.0	0.30	0.0093
8	10 ⁰ _{-0.006}	11.0	0.15	1	IR 8X10X11	9.2	0.15	0.0024
8	12 ⁰ _{-0.008}	10.0	0.30	1	IR 8X12X10	10.0	0.30	0.0048
8	12 ⁰ _{-0.008}	10.5	0.30	1	IR 8X12X10.5	10.0	0.30	0.0050
8	12 ⁰ _{-0.008}	12.0	0.30	-	IR 8X 2X12	10.0	0.30	0.0057
8	12 ⁰ _{-0.008}	12.5	0.30	1	IR 8X12X12.5	10.0	0.30	0.0059
8	14 ⁰ _{-0.008}	16.0	0.30	1	IR 8X14X16	10.0	0.30	0.0130
9	12 ⁰ _{-0.008}	11.0	0.30	1	IR 9X12X11	11.0	0.30	0.0041
9	12 ⁰ _{-0.008}	12.0	0.30	1	IR 9X12X12	11.0	0.30	0.0045
9	12 ⁰ _{-0.008}	16.0	0.30	1	IR 9X12X16	11.0	0.30	0.0061
9	15 ⁰ _{-0.008}	16.0	0.30	1	IR 9X15X16	11.0	0.30	0.0140
10	13 ⁰ _{-0.008}	12.5	0.30	1	IR 10X13X12.5	12.0	0.30	0.0052
10	14 ⁰ _{-0.008}	12.0	0.30	1	IR 10X14X12	12.0	0.30	0.0073
10	14 ⁰ _{-0.008}	13.0	0.30	1	IR 10X14X13	12.0	0.30	0.0074
10	14 ⁰ _{-0.008}	14.0	0.30	-	IR 10X14X14	12.0	0.30	0.0080

Notes: 1) The tolerance for this dimension provides regular clearance when an inner ring is combined with a needle roller bearing that lacks an inner ring.
2) These values are the allowable minimum dimensions of the chamfer dimension *r*.

**INNER RINGS
SERIES IR**

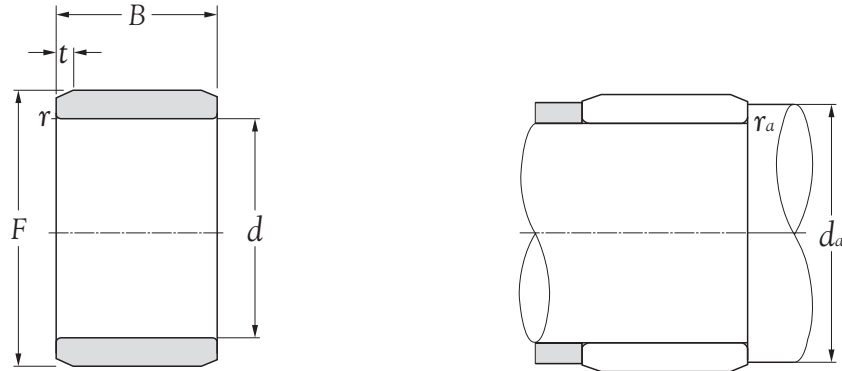

Boundary dimensions					Bearing numbers	Abutment dimensions		Mass kg (approx.)
mm						mm		
<i>d</i>	<i>F</i> ¹⁾	<i>B</i>	<i>r</i> <i>s min</i> ²⁾	<i>t</i>	<i>d</i> _{a min}	<i>r</i> _{a s max}		
10	14 ⁰ _{-0.008}	16.0	0.3	—	IR 10X14X16	12	0.3	0.0092
10	14 ⁰ _{-0.008}	20.0	0.3	1.0	IR 10X14X20	12	0.3	0.0120
10	15 ⁰ _{-0.008}	15.5	0.3	1.0	IR 10X15X15.5	12	0.3	0.0120
10	15 ⁰ _{-0.008}	20.5	0.3	1.0	IR 10X15X20.5	12	0.3	0.0150
10	16 ⁰ _{-0.008}	16.0	0.3	1.0	IR 10X16X16	12	0.3	0.0150
12	15 ⁰ _{-0.008}	12.0	0.3	1.0	IR 12X15X12	14	0.3	0.0058
12	15 ⁰ _{-0.008}	12.5	0.3	1.0	IR 12X15X12.5	14	0.3	0.0061
12	15 ⁰ _{-0.008}	16.0	0.3	1.0	IR 12X15X16	14	0.3	0.0078
12	15 ⁰ _{-0.008}	16.5	0.3	—	IR 12X15X16.5	14	0.3	0.0080
12	15 ⁰ _{-0.008}	22.5	0.3	—	IR 12X15X22.5	14	0.3	0.0110
12	16 ⁰ _{-0.008}	12.0	0.3	1.5	IR 12X16X12	14	0.3	0.0079
12	16 ⁰ _{-0.008}	13.0	0.3	1.5	IR 12X16X13	14	0.3	0.0087
12	16 ⁰ _{-0.008}	14.0	0.3	—	IR 12X16X14	14	0.3	0.0095
12	16 ⁰ _{-0.008}	16.0	0.3	1.5	IR 12X16X16	14	0.3	0.0110
12	16 ⁰ _{-0.008}	20.0	0.3	1.5	IR 12X16X20	14	0.3	0.0140
12	16 ⁰ _{-0.008}	22.0	0.3	1.5	IR 12X16X22	14	0.3	0.0150
12	17 ⁰ _{-0.008}	20.5	0.3	1.5	IR 12X17X20.5	14	0.3	0.0190
12	17 ⁰ _{-0.008}	25.5	0.3	1.5	IR 12X17X25.5	14	0.3	0.0240
12	18 ⁰ _{-0.008}	16.0	0.3	1.5	IR 12X18X16	14	0.3	0.0180
14	17 ⁰ _{-0.008}	17.0	0.3	1.5	IR 14X17X17	16	0.3	0.0095
15	18 ⁰ _{-0.008}	12.5	0.3	1.5	IR 15X18X12.5	17	0.3	0.0072
15	18 ⁰ _{-0.008}	16.0	0.3	1.5	IR 15X18X16	17	0.3	0.0093
15	18 ⁰ _{-0.008}	16.5	0.3	1.5	IR 15X18X16.5	17	0.3	0.0096
15	18 ⁰ _{-0.008}	17.5	0.3	1.5	IR 15X18X17.5	17	0.3	0.0100
15	18 ⁰ _{-0.008}	20.5	0.3	1.5	IR 15X18X20.5	17	0.3	0.0120
15	18 ⁰ _{-0.008}	25.5	0.3	1.5	IR 15X18X25.5	17	0.3	0.0150
15	19 ⁰ _{-0.009}	16.0	0.3	1.5	IR 15X19X16	17	0.3	0.0130
15	19 ⁰ _{-0.009}	20.0	0.3	1.5	IR 15X19X20	17	0.3	0.0160

Notes: 1) The tolerance for this dimension provides regular clearance when an inner ring is combined with a needle roller bearing that lacks an inner ring.
2) These values are the allowable minimum dimensions of the chamfer dimension *r*.

INNER RINGS
SERIES IR

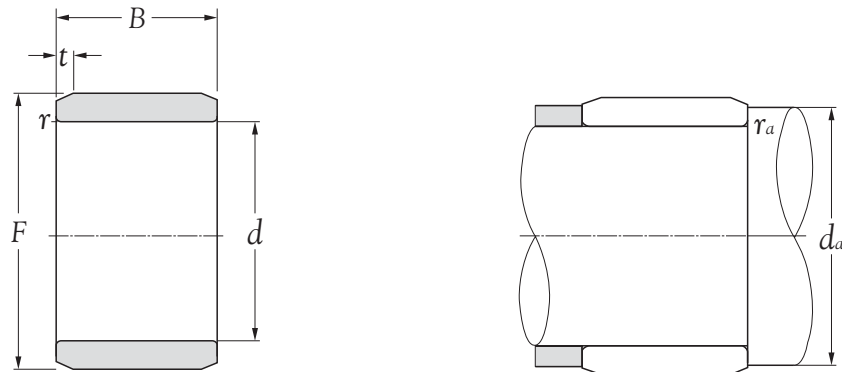

Boundary dimensions					Bearing numbers	Abutment dimensions		Mass kg (approx.)
mm						mm		
<i>d</i>	<i>F</i> ¹⁾	<i>B</i>	<i>r</i> <i>s min</i> ²⁾	<i>t</i>		<i>d</i> _{a min}	<i>r</i> _{a max}	
15	20 ⁰ _{-0.009}	12.0	0.3	1.5	IR 15X20X12	17	0.3	0.012
15	20 ⁰ _{-0.009}	13.0	0.3	1.5	IR 15X20X13	17	0.3	0.014
15	20 ⁰ _{-0.009}	14.0	0.3	-	IR 15X20X14	17	0.3	0.015
15	20 ⁰ _{-0.009}	18.0	0.3	1.5	IR 15X20X18	17	0.3	0.019
15	20 ⁰ _{-0.009}	20.5	0.3	1.5	IR 15X20X20.5	17	0.3	0.021
15	20 ⁰ _{-0.009}	23.0	0.3	-	IR 15X20X23	17	0.3	0.024
15	20 ⁰ _{-0.009}	26.0	0.3	1.5	IR 15X20X26	17	0.3	0.027
15	20 ⁰ _{-0.009}	30.5	0.3	1.5	IR 15X20X30.5	17	0.3	0.032
15	22 ⁰ _{-0.009}	20.0	0.6	1.5	IR 15X22X20	19	0.6	0.032
17	20 ⁰ _{-0.009}	16.0	0.3	1.5	IR 17X20X16	19	0.3	0.011
17	20 ⁰ _{-0.009}	16.5	0.3	1.5	IR 17X20X16.5	19	0.3	0.011
17	20 ⁰ _{-0.009}	20.0	0.3	1.5	IR 17X20X20	19	0.3	0.014
17	20 ⁰ _{-0.009}	20.5	0.3	-	IR 17X20X20.5	19	0.3	0.014
17	20 ⁰ _{-0.009}	30.5	0.3	-	IR 17X20X30.5	19	0.3	0.021
17	21 ⁰ _{-0.009}	16.0	0.3	1.5	IR 17X21X16	19	0.3	0.014
17	21 ⁰ _{-0.009}	20.0	0.3	-	IR 17X21X20	19	0.3	0.018
17	22 ⁰ _{-0.009}	13.0	0.3	1.5	IR 17X22X13	19	0.3	0.015
17	22 ⁰ _{-0.009}	14.0	0.3	-	IR 17X22X14	19	0.3	0.016
17	22 ⁰ _{-0.009}	16.0	0.3	-	IR 17X22X16	19	0.3	0.019
17	22 ⁰ _{-0.009}	18.0	0.3	1.5	IR 17X22X18	19	0.3	0.021
17	22 ⁰ _{-0.009}	20.5	0.3	1.5	IR 17X22X20.5	19	0.3	0.024
17	22 ⁰ _{-0.009}	23.0	0.3	-	IR 17X22X23	19	0.3	0.027
17	22 ⁰ _{-0.009}	26.0	0.3	1.5	IR 17X22X26	19	0.3	0.030
17	22 ⁰ _{-0.009}	32.0	0.3	1.5	IR 17X22X32	19	0.3	0.036
17	24 ⁰ _{-0.009}	20.0	0.6	1.5	IR 17X24X20	21	0.6	0.034
20	24 ⁰ _{-0.009}	16.0	0.3	1.8	IR 20X24X16	22	0.3	0.017
20	24 ⁰ _{-0.009}	20.0	0.3	-	IR 20X24X20	22	0.3	0.021
20	24 ⁰ _{-0.009}	28.5	0.3	-	IR 20X24X28.5	22	0.3	0.030

Notes: 1) The tolerance for this dimension provides regular clearance when an inner ring is combined with a needle roller bearing that lacks an inner ring.
2) These values are the allowable minimum dimensions of the chamfer dimension *r*.

INNER RINGS
SERIES IR

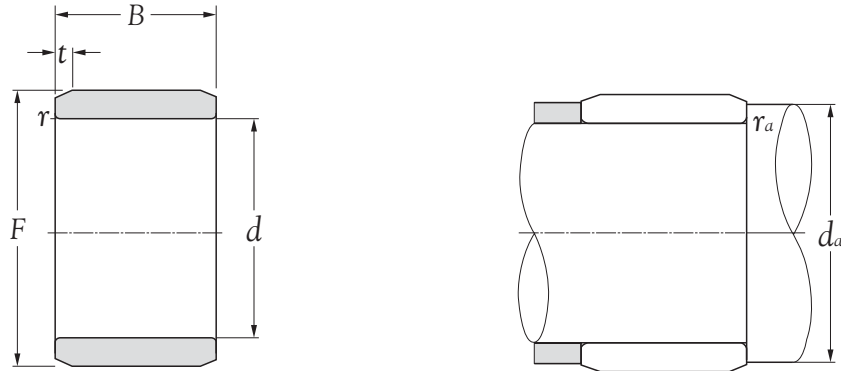

Boundary dimensions					Bearing numbers	Abutment dimensions		Mass kg (approx.)
mm						mm		
<i>d</i>	<i>F</i> ¹⁾	<i>B</i>	<i>r</i> <i>s min</i> ²⁾	<i>t</i>	<i>d</i> _{min}	<i>r</i> _{max}		
20	25 ⁰ _{-0.009}	12.5	0.3	1.8	IR 20X25X12.5	22	0.3	0.016
20	25 ⁰ _{-0.009}	16.0	0.3	-	IR 20X25X16	22	0.3	0.021
20	25 ⁰ _{-0.009}	16.5	0.3	1.8	IR 20X25X16.5	22	0.3	0.022
20	25 ⁰ _{-0.009}	17.0	0.3	1.8	IR 20X25X17	22	0.3	0.022
20	25 ⁰ _{-0.009}	18.0	0.3	-	IR 20X25X18	22	0.3	0.024
20	25 ⁰ _{-0.009}	20.0	0.3	-	IR 20X25X20	22	0.3	0.027
20	25 ⁰ _{-0.009}	20.5	0.3	1.8	IR 20X25X20.5	22	0.3	0.028
20	25 ⁰ _{-0.009}	23.0	0.3	1.8	IR 20X25X23	22	0.3	0.031
20	25 ⁰ _{-0.009}	26.0	0.3	1.8	IR 20X25X26	22	0.3	0.034
20	25 ⁰ _{-0.009}	26.5	0.3	-	IR 20X25X26.5	22	0.3	0.036
20	25 ⁰ _{-0.009}	30.0	0.3	1.8	IR 20X25X30	22	0.3	0.041
20	25 ⁰ _{-0.009}	32.0	0.3	1.8	IR 20X25X32	22	0.3	0.041
20	25 ⁰ _{-0.009}	38.5	0.3	-	IR 20X25X38.5	22	0.3	0.053
20	28 ⁰ _{-0.009}	20.0	0.6	1.8	IR 20X28X20	24	0.6	0.045
22	26 ⁰ _{-0.009}	16.0	0.3	1.8	IR 22X26X16	24	0.3	0.017
22	26 ⁰ _{-0.009}	20.0	0.3	-	IR 22X26X20	24	0.3	0.022
22	28 ⁰ _{-0.009}	17.0	0.3	1.8	IR 22X28X17	24	0.3	0.030
22	28 ⁰ _{-0.009}	20.0	0.3	1.8	IR 22X28X20	24	0.3	0.035
22	28 ⁰ _{-0.009}	20.5	0.3	1.8	IR 22X28X20.5	24	0.3	0.036
22	28 ⁰ _{-0.009}	23.0	0.3	1.8	IR 22X28X23	24	0.3	0.042
22	28 ⁰ _{-0.009}	30.0	0.3	-	IR 22X28X30	24	0.3	0.054
25	29 ⁰ _{-0.009}	20.0	0.3	-	IR 25X29X20	27	0.3	0.026
25	29 ⁰ _{-0.009}	30.0	0.3	1.8	IR 25X29X30	27	0.3	0.039
25	30 ⁰ _{-0.009}	12.5	0.3	1.8	IR 25X30X12.5	27	0.3	0.020
25	30 ⁰ _{-0.009}	16.0	0.3	1.0	IR 25X30X16	27	0.3	0.024
25	30 ⁰ _{-0.009}	16.5	0.3	1.8	IR 25X30X16.5	27	0.3	0.026
25	30 ⁰ _{-0.009}	17.0	0.3	1.8	IR 25X30X17	27	0.3	0.027
25	30 ⁰ _{-0.009}	18.0	0.3	-	IR 25X30X18	27	0.3	0.030

Notes: 1) The tolerance for this dimension provides regular clearance when an inner ring is combined with a needle roller bearing that lacks an inner ring.
2) These values are the allowable minimum dimensions of the chamfer dimension *r*.

INNER RINGS
SERIES IR

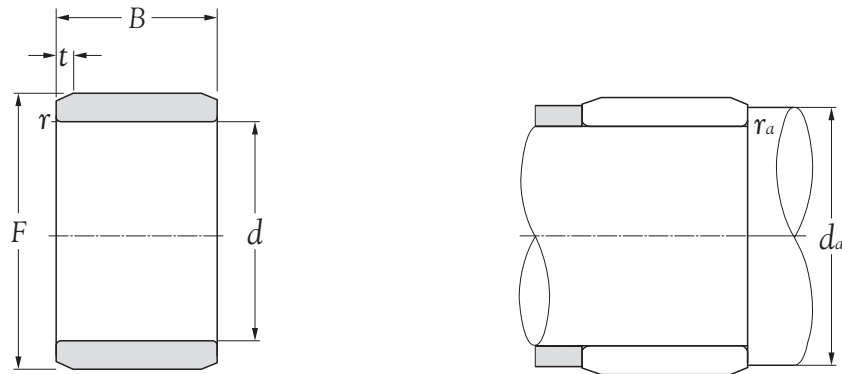

Boundary dimensions					Bearing numbers	Abutment dimensions		Mass kg (approx.)
mm						mm		
<i>d</i>	<i>F</i> ¹⁾	<i>B</i>	<i>r</i> <i>s min</i> ²⁾	<i>t</i>	<i>d</i> _{min}	<i>r</i> _{max}		
25	30 ⁰ _{-0.009}	20.0	0.3	1.8	IR 25X30X20	27	0.3	0.033
25	30 ⁰ _{-0.009}	20.5	0.3	1.8	IR 25X30X20.5	27	0.3	0.034
25	30 ⁰ _{-0.009}	23.0	0.3	1.8	IR 25X30X23	27	0.3	0.038
25	30 ⁰ _{-0.009}	26.0	0.3	1.8	IR 25X30X26	27	0.3	0.041
25	30 ⁰ _{-0.009}	26.5	0.3	-	IR 25X30X26.5	27	0.3	0.043
25	30 ⁰ _{-0.009}	30.0	0.3	1.8	IR 25X30X30	27	0.3	0.050
25	30 ⁰ _{-0.009}	32.0	0.3	1.0	IR 25X30X32	27	0.3	0.054
25	30 ⁰ _{-0.009}	38.5	0.3	-	IR 25X30X38.5	27	0.3	0.064
25	32 ^{+0.008} _{-0.002}	22.0	0.6	1.8	IR 25X32X22	29	0.6	0.052
25	32 ^{+0.008} _{-0.002}	30.5	0.6	1.8	IR 25X32X30.5	29	0.6	0.072
28	32 ^{+0.008} _{-0.002}	17.0	0.3	1.8	IR 28X32X17	30	0.3	0.025
28	32 ^{+0.008} _{-0.002}	20.0	0.3	1.8	IR 28X32X20	30	0.3	0.028
28	32 ^{+0.008} _{-0.002}	23.0	0.3	1.8	IR 28X32X23	30	0.3	0.034
28	32 ^{+0.008} _{-0.002}	30.0	0.3	-	IR 28X32X30	30	0.3	0.044
29	32 ^{+0.008} _{-0.002}	13.0	0.3	1.8	IR 29X32X13	31	0.3	0.015
30	35 ^{+0.008} _{-0.002}	12.5	0.3	1.8	IR 30X35X12.5	32	0.3	0.024
30	35 ^{+0.008} _{-0.002}	13.0	0.3	1.3	IR 30X35X13	32	0.3	0.025
30	35 ^{+0.008} _{-0.002}	16.0	0.3	-	IR 30X35X16	32	0.3	0.031
30	35 ^{+0.008} _{-0.002}	16.5	0.3	1.8	IR 30X35X16.5	32	0.3	0.032
30	35 ^{+0.008} _{-0.002}	17.0	0.3	1.8	IR 30X35X17	32	0.3	0.032
30	35 ^{+0.008} _{-0.002}	18.0	0.3	-	IR 30X35X18	32	0.3	0.035
30	35 ^{+0.008} _{-0.002}	20.0	0.3	-	IR 30X35X20	32	0.3	0.038
30	35 ^{+0.008} _{-0.002}	20.5	0.3	1.8	IR 30X35X20.5	32	0.3	0.039
30	35 ^{+0.008} _{-0.002}	23.0	0.3	1.8	IR 30X35X23	32	0.3	0.044
30	35 ^{+0.008} _{-0.002}	26.0	0.3	1.8	IR 30X35X26	32	0.3	0.050
30	35 ^{+0.008} _{-0.002}	30.0	0.3	-	IR 30X35X30	32	0.3	0.059
30	35 ^{+0.008} _{-0.002}	32.0	0.3	1.8	IR 30X35X32	32	0.3	0.063
30	37 ^{+0.008} _{-0.002}	18.0	0.3	1.8	IR 30X37X18	32	0.3	0.050

Notes: 1) The tolerance for this dimension provides regular clearance when an inner ring is combined with a needle roller bearing that lacks an inner ring.
2) These values are the allowable minimum dimensions of the chamfer dimension *r*.

**INNER RINGS
SERIES IR**

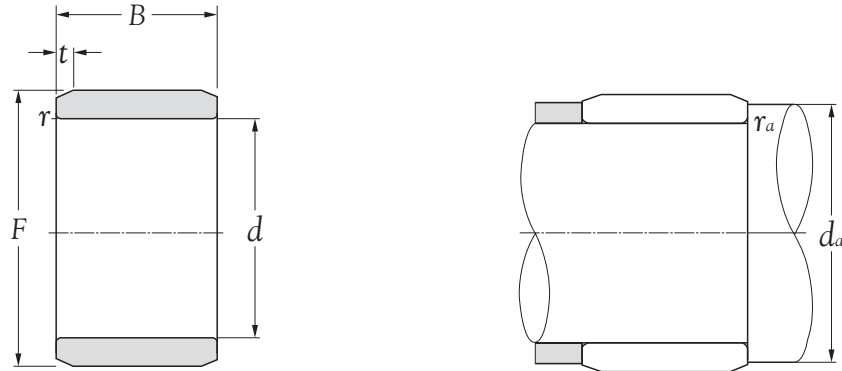

Boundary dimensions					Bearing numbers	Abutment dimensions		Mass kg (approx.)
mm						mm		
<i>d</i>	<i>F</i> ¹⁾	<i>B</i>	<i>r</i> <i>s min</i> ²⁾	<i>t</i>	<i>d</i> _{a min}	<i>r</i> _{a s max}		
30	37 ^{+0.008} / _{-0.002}	22.0	0.6	1.8	IR 30X37X22	34	0.6	0.061
30	38 ^{+0.008} / _{-0.002}	20.0	0.6	-	IR 30X38X20	34	0.6	0.065
32	37 ⁰ / _{-0.011}	20.0	0.3	2.0	IR 32X37X20	34	0.3	0.040
32	37 ⁰ / _{-0.011}	30.0	0.3	-	IR 32X37X30	34	0.3	0.063
32	38 ⁰ / _{-0.011}	32.0	0.3	2.0	IR 32X38X32	34	0.3	0.082
32	40 ⁰ / _{-0.011}	20.0	0.6	2.0	IR 32X40X20	36	0.6	0.068
32	40 ⁰ / _{-0.011}	27.0	0.6	2.0	IR 32X40X27	36	0.6	0.092
32	40 ⁰ / _{-0.011}	36.0	0.6	2.0	IR 32X40X36	36	0.6	0.124
33	37 ⁰ / _{-0.011}	13.0	0.3	2.0	IR 33X37X13	35	0.3	0.022
35	40 ⁰ / _{-0.011}	12.5	0.3	2.0	IR 35X40X12.5	37	0.3	0.027
35	40 ⁰ / _{-0.011}	16.5	0.3	2.0	IR 35X40X16.5	37	0.3	0.037
35	40 ⁰ / _{-0.011}	17.0	0.3	2.0	IR 35X40X17	37	0.3	0.038
35	40 ⁰ / _{-0.011}	20.0	0.3	2.0	IR 35X40X20	37	0.3	0.044
35	40 ⁰ / _{-0.011}	20.5	0.3	2.0	IR 35X40X20.5	37	0.3	0.046
35	40 ⁰ / _{-0.011}	30.0	0.3	-	IR 35X40X30	37	0.3	0.068
35	40 ⁰ / _{-0.011}	34.0	0.3	1.8	IR 35X40X34	37	0.3	0.079
35	40 ⁰ / _{-0.011}	40.0	0.3	2.0	IR 35X40X40	37	0.3	0.091
35	42 ⁰ / _{-0.011}	20.0	0.6	1.8	IR 35X42X20	39	0.6	0.064
35	42 ⁰ / _{-0.011}	21.0	0.6	-	IR 35X42X21	39	0.6	0.068
35	42 ⁰ / _{-0.011}	23.0	0.6	-	IR 35X42X23	39	0.6	0.074
35	42 ⁰ / _{-0.011}	27.0	0.6	2.0	IR 35X42X27	39	0.6	0.080
35	42 ⁰ / _{-0.011}	36.0	0.6	2.0	IR 35X42X36	39	0.6	0.117
35	43 ⁰ / _{-0.011}	22.0	0.6	2.0	IR 35X43X22	39	0.6	0.081
38	43 ⁰ / _{-0.011}	20.0	0.3	1.8	IR 38X43X20	40	0.3	0.048
38	43 ⁰ / _{-0.011}	30.0	0.3	-	IR 38X43X30	40	0.3	0.074
40	45 ⁰ / _{-0.011}	16.5	0.3	2.0	IR 40X45X16.5	42	0.3	0.042
40	45 ⁰ / _{-0.011}	17.0	0.3	2.0	IR 40X45X17	42	0.3	0.043
40	45 ⁰ / _{-0.011}	20.0	0.3	2.0	IR 40X45X20	42	0.3	0.051

Notes: 1) The tolerance for this dimension provides regular clearance when an inner ring is combined with a needle roller bearing that lacks an inner ring.
2) These values are the allowable minimum dimensions of the chamfer dimension *r*.

INNER RINGS
SERIES IR

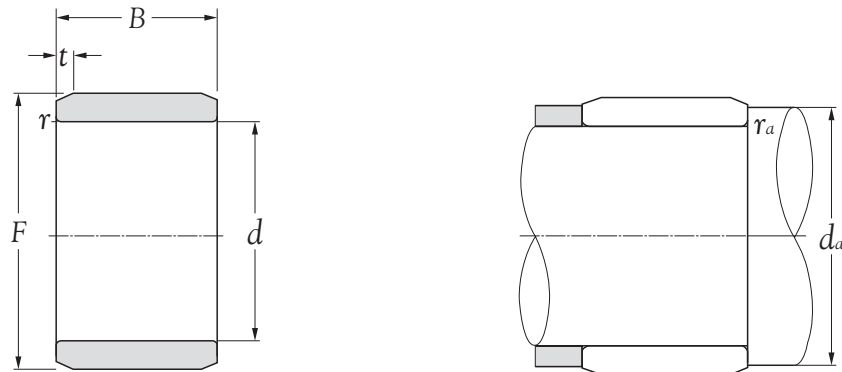

Boundary dimensions					Bearing numbers	Abutment dimensions		Mass kg (approx.)
mm						mm		
<i>d</i>	<i>F</i> ¹⁾	<i>B</i>	<i>r</i> <i>s min</i> ²⁾	<i>t</i>	<i>d</i> _{min}	<i>r</i> _{max}		
40	45 ⁰ _{-0.011}	20.5	0.3	2.0	IR 40X45X20.5	42	0.3	0.053
40	45 ⁰ _{-0.011}	26.5	0.3	-	IR 40X45X26.5	42	0.3	0.068
40	45 ⁰ _{-0.011}	30.0	0.3	2.0	IR 40X45X30	42	0.3	0.077
40	45 ⁰ _{-0.011}	34.0	0.3	2.0	IR 40X45X34	42	0.3	0.088
40	45 ⁰ _{-0.011}	40.0	0.3	2.0	IR 40X45X40	42	0.3	0.106
40	48 ⁰ _{-0.011}	22.0	0.6	2.0	IR 40X48X22	44	0.6	0.092
40	48 ⁰ _{-0.011}	23.0	0.6	-	IR 40X48X23	44	0.6	0.097
40	48 ⁰ _{-0.011}	30.0	0.6	2.0	IR 40X48X30	44	0.6	0.123
40	48 ⁰ _{-0.011}	40.0	0.6	2.0	IR 40X48X40	44	0.6	0.170
40	50 ⁰ _{-0.011}	20.0	0.3	0.8	IR 40X48X20	44	0.3	0.106
40	50 ⁰ _{-0.011}	22.0	1.0	2.0	IR 40X50X22	45	1.0	0.118
42	47 ⁰ _{-0.011}	20.0	0.3	2.0	IR 42X47X20	44	0.3	0.053
42	47 ⁰ _{-0.011}	30.0	0.3	2.0	IR 42X47X30	44	0.3	0.080
45	50 ⁰ _{-0.011}	20.0	0.3	2.0	IR 45X50X20	47	0.3	0.057
45	50 ⁰ _{-0.011}	25.0	0.6	2.0	IR 45X50X25	49	0.6	0.071
45	50 ⁰ _{-0.011}	25.5	0.3	-	IR 45X50X25.5	47	0.3	0.074
45	50 ⁰ _{-0.011}	32.0	0.6	-	IR 45X50X32	49	0.6	0.092
45	50 ⁰ _{-0.011}	35.0	0.6	2.0	IR 45X50X35	49	0.6	0.101
45	50 ⁰ _{-0.011}	40.0	0.3	1.5	IR 45X50X40	47	0.3	0.115
45	52 ^{+0.008} _{-0.004}	22.0	0.6	2.0	IR 45X52X22	49	0.6	0.088
45	52 ^{+0.008} _{-0.004}	23.0	0.6	-	IR 45X52X23	49	0.6	0.093
45	52 ^{+0.008} _{-0.004}	30.0	0.6	2.0	IR 45X52X30	49	0.6	0.123
45	52 ^{+0.008} _{-0.004}	40.0	0.6	2.0	IR 45X52X40	49	0.6	0.164
45	55 ^{+0.008} _{-0.004}	20.0	0.6	2.0	IR 45X55X20	49	0.6	0.116
45	55 ^{+0.008} _{-0.004}	22.0	1.0	2.0	IR 45X55X22	50	1.0	0.130
45	55 ^{+0.008} _{-0.004}	40.0	0.6	2.0	IR 45X55X40	49	0.6	0.173
50	55 ^{+0.008} _{-0.004}	20.0	0.6	2.0	IR 50X55X20	54	0.6	0.063
50	55 ^{+0.008} _{-0.004}	25.0	0.6	2.0	IR 50X55X25	54	0.6	0.780

Notes: 1) The tolerance for this dimension provides regular clearance when an inner ring is combined with a needle roller bearing that lacks an inner ring.
2) These values are the allowable minimum dimensions of the chamfer dimension *r*.

**INNER RINGS
SERIES IR**

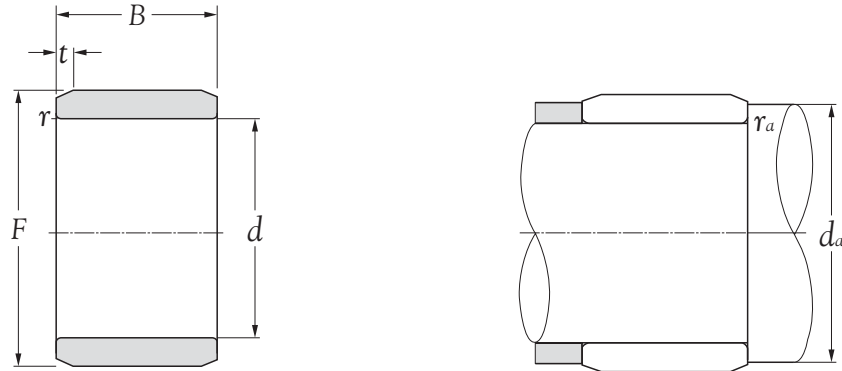

Boundary dimensions					Bearing numbers	Abutment dimensions		Mass kg (approx.)
mm						mm		
<i>d</i>	<i>F</i> ¹⁾	<i>B</i>	<i>r_s min</i> ²⁾	<i>t</i>	<i>d_a min</i>	<i>r_{as} max</i>		
50	55 ^{+0.008/-0.004}	35	0.6	2.0	IR 50X55X35	54.0	0.6	0.112
50	55 ^{+0.008/-0.004}	40	0.6	2.0	IR 50X55X40	54.0	0.6	0.128
50	58 ^{+0.008/-0.004}	22	0.6	2.0	IR 50X58X22	54.0	0.6	0.113
50	58 ^{+0.008/-0.004}	23	0.6	-	IR 50X58X23	54.0	0.6	0.119
50	58 ^{+0.008/-0.004}	30	0.6	2.0	IR 50X58X30	54.0	0.6	0.159
50	58 ^{+0.008/-0.004}	40	0.6	2.0	IR 50X58X40	54.0	0.6	0.209
50	60 ^{+0.008/-0.004}	20	1.0	2.0	IR 50X60X20	55.0	1.0	0.129
50	60 ^{+0.008/-0.004}	25	1.0	2.0	IR 50X60X25	55.0	1.0	0.163
50	60 ^{+0.008/-0.004}	28	1.1	2.0	IR 50X60X28	56.5	1.0	0.183
50	60 ^{+0.008/-0.004}	40	1.0	2.0	IR 50X60X40	55.0	1.0	0.262
55	60 ^{0/-0.013}	25	0.6	2.2	IR 55X60X25	59.0	0.6	0.086
55	60 ^{0/-0.013}	35	0.6	2.0	IR 55X60X35	59.0	0.6	0.121
55	63 ^{0/-0.013}	25	1.0	2.0	IR 55X63X25	60.0	1.0	0.141
55	63 ^{0/-0.013}	34	1.0	2.2	IR 55X63X34	60.0	1.0	0.192
55	63 ^{0/-0.013}	45	1.0	2.2	IR 55X63X45	60.0	1.0	0.256
55	65 ^{0/-0.013}	28	1.1	2.2	IR 55X65X28	61.5	1.0	0.206
55	65 ^{0/-0.013}	30	1.0	2.2	IR 55X65X30	60.0	1.0	0.220
55	65 ^{0/-0.013}	60	1.0	1.5	IR 55X65X60	60.0	1.0	0.440
60	68 ^{0/-0.013}	25	1.0	2.2	IR 60X68X25	65.0	1.0	0.152
60	68 ^{0/-0.013}	34	1.0	2.2	IR 60X68X34	65.0	1.0	0.206
60	68 ^{0/-0.013}	35	0.6	2.2	IR 60X68X35	64.0	0.6	0.213
60	68 ^{0/-0.013}	45	1.0	2.2	IR 60X68X45	65.0	1.0	0.270
60	70 ^{0/-0.013}	25	1.0	2.2	IR 60X70X25	65.0	1.0	0.195
60	70 ^{0/-0.013}	28	1.1	2.2	IR 60X70X28	66.5	1.0	0.216
60	70 ^{0/-0.013}	30	1.0	2.2	IR 60X70X30	65.0	1.0	0.232
60	70 ^{0/-0.013}	60	1.0	2.2	IR 60X70X60	65.0	1.0	0.463
65	72 ^{0/-0.013}	25	1.0	2.2	IR 65X72X25	70.0	1.0	0.142
65	72 ^{0/-0.013}	34	1.0	2.2	IR 65X72X34	70.0	1.0	0.193

Notes: 1) The tolerance for this dimension provides regular clearance when an inner ring is combined with a needle roller bearing that lacks an inner ring.
2) These values are the allowable minimum dimensions of the chamfer dimension *r*.

INNER RINGS
SERIES IR

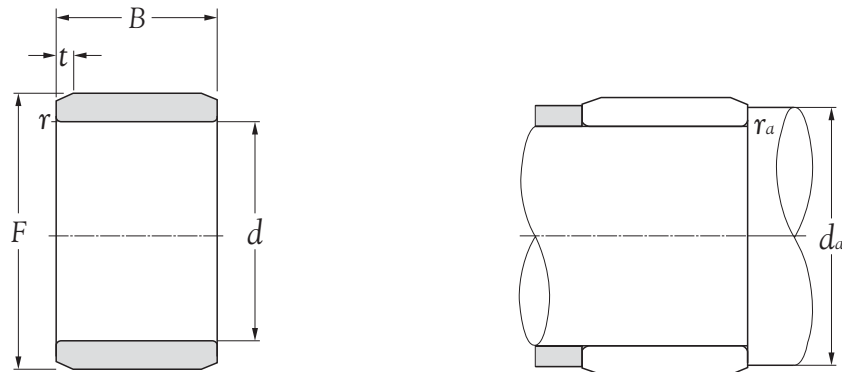

Boundary dimensions					Bearing numbers	Abutment dimensions		Mass kg (approx.)
mm						mm		
<i>d</i>	<i>F</i> ¹⁾	<i>B</i>	<i>r</i> s min ²⁾	<i>t</i>		<i>d</i> _{a min}	<i>r</i> _{a max}	
65	72 ⁰ _{-0.013}	45	1.0	2.2	IR 65X72X45	70.0	1.0	0.259
65	73 ⁰ _{-0.013}	25	0.6	2.2	IR 65X73X25	69.0	0.6	0.164
65	73 ⁰ _{-0.013}	35	0.6	2.2	IR 65X73X35	69.0	0.6	0.232
65	75 ⁰ _{-0.013}	28	1.1	2.2	IR 65X75X28	71.5	1.0	0.240
65	75 ⁰ _{-0.013}	30	1.0	2.2	IR 65X75X30	70.0	1.0	0.256
65	75 ⁰ _{-0.013}	60	1.0	2.2	IR 65X75X60	70.0	1.0	0.513
70	80 ⁰ _{-0.013}	25	1.0	2.2	IR 70X80X25	75.0	1.0	0.224
70	80 ⁰ _{-0.013}	28	1.1	2.2	IR 70X80X28	76.5	1.0	0.250
70	80 ⁰ _{-0.013}	30	1.0	2.2	IR 70X80X30	75.0	1.0	0.267
70	80 ⁰ _{-0.013}	35	1.0	2.2	IR 70X80X35	75.0	1.0	0.313
70	80 ⁰ _{-0.013}	40	1.0	2.2	IR 70X80X40	75.0	1.0	0.358
70	80 ⁰ _{-0.013}	54	1.0	2.2	IR 70X80X54	75.0	1.0	0.483
70	80 ⁰ _{-0.013}	56	1.0	2.2	IR 70X80X56	75.0	1.0	0.502
70	80 ⁰ _{-0.013}	60	1.0	2.2	IR 70X80X60	75.0	1.0	0.540
75	85 ⁰ _{-0.015}	25	1.0	2.2	IR 75X85X25	80.0	1.0	0.238
75	85 ⁰ _{-0.015}	30	1.0	2.2	IR 75X85X30	80.0	1.0	0.287
75	85 ⁰ _{-0.015}	35	1.0	2.2	IR 75X85X35	80.0	1.0	0.336
75	85 ⁰ _{-0.015}	40	1.0	2.2	IR 75X85X40	80.0	1.0	0.385
75	85 ⁰ _{-0.015}	54	1.0	2.2	IR 75X85X54	80.0	1.0	0.515
75	90 ⁰ _{-0.015}	32	1.1	2.2	IR 75X90X32	81.5	1.0	0.480
80	90 ⁰ _{-0.015}	25	1.0	2.2	IR 80X90X25	85.0	1.0	0.254
80	90 ⁰ _{-0.015}	30	1.0	2.2	IR 80X90X30	85.0	1.0	0.304
80	90 ⁰ _{-0.015}	35	1.0	2.2	IR 80X90X35	85.0	1.0	0.355
80	90 ⁰ _{-0.015}	40	1.0	2.2	IR 80X90X40	85.0	1.0	0.408
80	90 ⁰ _{-0.015}	54	1.0	2.2	IR 80X90X54	85.0	1.0	0.543
80	95 ⁰ _{-0.015}	32	1.1	2.2	IR 80X95X32	86.5	1.0	0.510
85	95 ⁰ _{-0.015}	26	1.0	2.5	IR 85X95X26	90.0	1.0	0.280
85	95 ⁰ _{-0.015}	30	1.0	2.5	IR 85X95X30	90.0	1.0	0.323

Notes: 1) The tolerance for this dimension provides regular clearance when an inner ring is combined with a needle roller bearing that lacks an inner ring.
2) These values are the allowable minimum dimensions of the chamfer dimension *r*.

INNER RINGS
SERIES IR

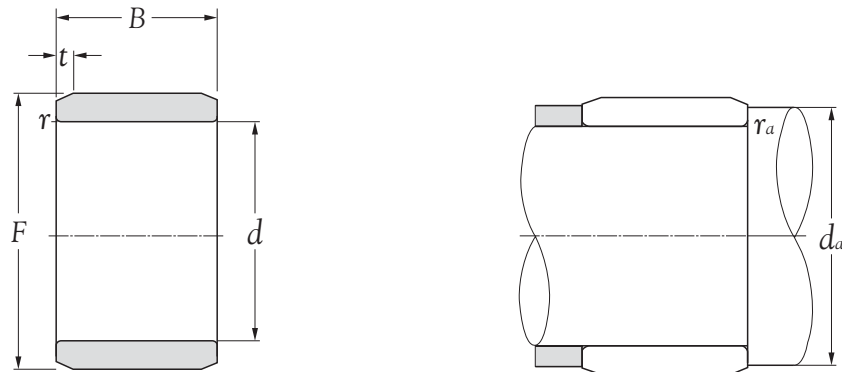

Boundary dimensions					Bearing numbers	Abutment dimensions		Mass kg (approx.)
mm						mm		
<i>d</i>	<i>F</i> ¹⁾	<i>B</i>	<i>r_s min</i> ²⁾	<i>t</i>		<i>d_a min</i>	<i>r_{as} max</i>	
85	95 ⁰ _{-0.015}	36	1.0	2.5	IR 85X95X36	90.0	1	0.398
85	100 ⁰ _{-0.015}	32	1.1	2.5	IR 85X100X32	91.5	1	0.530
85	100 ⁰ _{-0.015}	35	1.1	2.5	IR 85X100X35	91.5	1	0.580
85	100 ⁰ _{-0.015}	46	1.1	2.5	IR 85X100X46	91.5	1	0.760
85	100 ⁰ _{-0.015}	63	1.1	2.5	IR 85X100X63	91.5	1	1.050
90	100 ⁰ _{-0.015}	26	1.0	2.5	IR 90X100X26	95.0	1	0.294
90	100 ⁰ _{-0.015}	30	1.0	2.5	IR 90X100X30	95.0	1	0.340
90	100 ⁰ _{-0.015}	36	1.0	2.5	IR 90X100X36	95.0	1	0.406
90	105 ⁰ _{-0.015}	32	1.1	2.5	IR 90X105X32	96.5	1	0.560
90	105 ⁰ _{-0.015}	35	1.1	2.5	IR 90X105X35	96.5	1	0.610
90	105 ⁰ _{-0.015}	46	1.1	2.5	IR 90X105X46	96.5	1	0.800
90	105 ⁰ _{-0.015}	63	1.1	2.5	IR 90X105X63	96.5	1	1.110
95	105 ⁰ _{-0.015}	26	1.0	2.5	IR 95X105X26	100.0	1	0.313
95	105 ⁰ _{-0.015}	36	1.0	2.5	IR 95X105X36	100.0	1	0.430
95	110 ⁰ _{-0.015}	32	1.1	2.5	IR 95X110X32	101.5	1	0.590
95	110 ⁰ _{-0.015}	35	1.1	2.5	IR 95X110X35	101.5	1	0.640
95	110 ⁰ _{-0.015}	46	1.1	2.5	IR 95X110X46	101.5	1	0.850
95	110 ⁰ _{-0.015}	63	1.1	2.5	IR 95X110X63	101.5	1	1.170
100	110 ⁰ _{-0.015}	30	1.1	2.5	IR 100X110X30	106.5	1	0.375
100	110 ⁰ _{-0.015}	40	1.1	2.5	IR 100X110X40	106.5	1	0.505
100	115 ⁰ _{-0.015}	32	1.1	2.5	IR 100X115X32	106.5	1	0.620
100	115 ⁰ _{-0.015}	40	1.1	2.5	IR 100X115X40	106.5	1	0.775
100	115 ⁰ _{-0.015}	54	1.1	2.5	IR 100X115X54	106.5	1	1.090
110	120 ⁰ _{-0.015}	30	1.0	2.5	IR 110X120X30	115.0	1	0.440
110	120 ⁰ _{-0.015}	40	1.1	2.5	IR 110X120X40	116.5	1	0.580
110	125 ⁰ _{-0.018}	40	1.1	2.5	IR 110X125X40	116.5	1	0.840
110	125 ⁰ _{-0.018}	54	1.1	2.5	IR 110X125X54	116.5	1	1.160
120	130 ⁰ _{-0.018}	30	1.0	2.2	IR 120X130X30	125.0	1	0.440

Notes: 1) The tolerance for this dimension provides regular clearance when an inner ring is combined with a needle roller bearing that lacks an inner ring.
2) These values are the allowable minimum dimensions of the chamfer dimension *r*.

INNER RINGS
SERIES IR

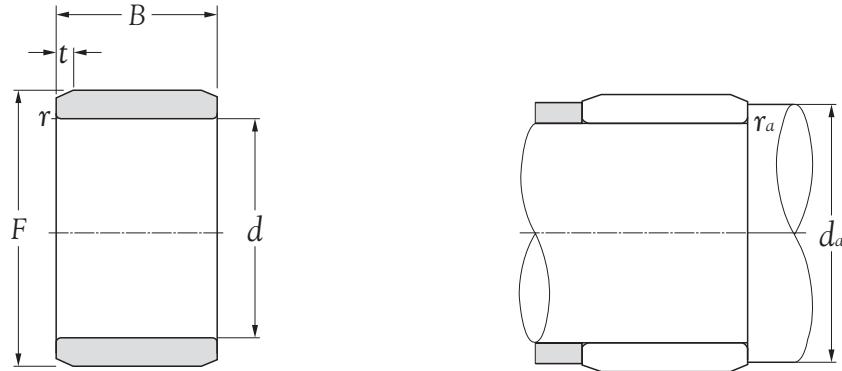

Boundary dimensions					Bearing numbers	Abutment dimensions		Mass kg (approx.)
mm						mm		
<i>d</i>	<i>F</i> ¹⁾	<i>B</i>	<i>r_s min</i> ²⁾	<i>t</i>		<i>d_a min</i>	<i>r_{as} max</i>	
120	130 ^{0 -0.018}	40	1.1	2.5	IR 120X130X40	126.5	1.0	0.590
120	135 ^{0 -0.018}	40	2.0	2.5	IR 120X135X40	129.0	2.0	0.870
120	135 ^{0 -0.018}	45	1.1	2.5	IR 120X135X45	126.5	1.0	0.980
120	135 ^{0 -0.018}	60	1.1	2.5	IR 120X135X60	126.5	1.0	1.250
130	145 ^{0 -0.018}	32	1.5	3.0	IR 130X145X32	138.0	1.5	0.780
130	145 ^{0 -0.018}	35	1.1	3.0	IR 130X145X35	136.5	1.0	0.855
130	145 ^{0 -0.018}	42	1.5	3.0	IR 130X145X42	138.0	1.5	1.050
130	150 ^{0 -0.018}	50	1.5	3.0	IR 130X150X50	138.0	1.5	1.690
130	150 ^{0 -0.018}	52	2.0	3.0	IR 130X150X52	139.0	2.0	1.750
130	150 ^{0 -0.018}	67	1.5	3.0	IR 130X150X67	138.0	1.5	2.250
140	155 ^{0 -0.018}	32	1.5	3.0	IR 140X155X32	148.0	1.5	0.840
140	155 ^{0 -0.018}	35	1.1	3.0	IR 140X155X35	146.5	1.0	0.917
140	155 ^{0 -0.018}	42	1.5	3.0	IR 140X155X42	148.0	1.5	1.100
140	160 ^{0 -0.018}	50	1.5	3.0	IR 140X160X50	148.0	1.5	1.700
140	160 ^{0 -0.018}	52	2.0	3.0	IR 140X160X52	149.0	2.0	1.780
140	160 ^{0 -0.018}	67	1.5	3.0	IR 140X160X67	148.0	1.5	2.300
150	165 ^{-0.017 -0.035}	32	1.5	3.0	IR 150X165X32	158.0	1.5	0.900
150	165 ^{-0.017 -0.035}	40	1.1	3.0	IR 150X165X40	156.5	1.0	1.120
150	165 ^{-0.017 -0.035}	42	1.5	3.0	IR 150X165X42	158.0	1.5	1.180
150	170 ^{-0.017 -0.035}	52	2.0	3.0	IR 150X170X52	159.0	2.0	2.000
150	170 ^{-0.017 -0.035}	60	2.0	3.0	IR 150X170X60	159.0	2.0	2.350
160	175 ^{-0.017 -0.035}	40	1.1	3.0	IR 160X175X40	166.5	1.0	1.200
160	180 ^{-0.017 -0.035}	60	2.0	3.0	IR 160X180X60	169.0	2.0	2.500
170	185 ^{-0.013 -0.043}	45	1.1	3.0	IR 170X185X45	176.5	1.0	1.450
170	190 ^{-0.013 -0.043}	60	2.0	3.0	IR 170X190X60	179.0	2.0	2.650
180	195 ^{-0.013 -0.043}	45	1.1	3.0	IR 180X195X45	186.5	1.0	1.510
180	205 ^{-0.013 -0.043}	69	2.0	3.0	IR 180X205X69	189.0	2.0	4.100
190	210 ^{-0.020 -0.050}	50	1.5	3.5	IR 190X210X50	198.0	1.5	2.410

Notes: 1) The tolerance for this dimension provides regular clearance when an inner ring is combined with a needle roller bearing that lacks an inner ring.
2) These values are the allowable minimum dimensions of the chamfer dimension *r*.

INNER RINGS
SERIES IR

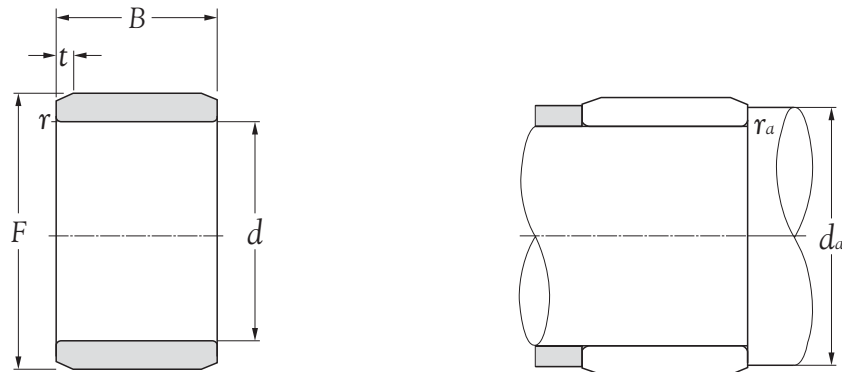

Boundary dimensions					Bearing numbers	Abutment dimensions		Mass kg (approx.)
mm						mm		
<i>d</i>	<i>F</i> ¹⁾	<i>B</i>	<i>r</i> s min ²⁾	<i>t</i>	<i>d</i> _{a min}	<i>r</i> _{a max}		
190	215 <small>-0.020 -0.050</small>	69	2.0	3.5	IR 190X215X69	199	2.0	4.100
200	220 <small>-0.020 -0.050</small>	50	1.5	3.5	IR 200X220X50	208	1.5	2.490
200	225 <small>-0.020 -0.050</small>	80	2.1	3.5	IR 200X220X80	211	2.0	5.100
220	240 <small>-0.033 -0.063</small>	50	1.5	3.5	IR 220X240X50	228	1.5	2.750
220	245 <small>-0.033 -0.063</small>	80	2.1	3.5	IR 220X245X80	231	2.0	5.700
240	265 <small>-0.037 -0.069</small>	60	2.0	3.5	IR 240X265X60	249	2.0	4.600
240	265 <small>-0.037 -0.069</small>	80	2.1	3.5	IR 240X265X80	251	2.0	6.300
260	285 <small>-0.064 -0.092</small>	60	2.0	4.0	IR 260X285X60	269	2.0	4.980
260	290 <small>-0.064 -0.092</small>	100	2.1	4.0	IR 260X290X100	271	2.0	10.000
280	305 <small>-0.064 -0.092</small>	69	2.0	4.0	IR 280X305X69	289	2.0	6.200
280	310 <small>-0.064 -0.092</small>	100	2.1	4.0	IR 280X310X100	291	2.0	10.800
300	330 <small>-0.062 -0.098</small>	80	2.1	4.0	IR 300X330X80	311	2.0	9.300
300	340 <small>-0.062 -0.098</small>	118	3.0	4.0	IR 300X340X118	313	2.5	18.500
320	350 <small>-0.062 -0.098</small>	80	2.1	5.0	IR 320X350X80	331	2.0	9.800
320	360 <small>-0.062 -0.098</small>	118	3.0	5.0	IR 320X360X118	333	2.5	20.000
340	370 <small>-0.062 -0.098</small>	80	2.1	5.0	IR 340X370X80	351	2.0	10.100
340	380 <small>-0.062 -0.098</small>	118	3.0	5.0	IR 340X380X118	353	2.5	22.000
360	390 <small>-0.090 -0.126</small>	80	2.1	5.0	IR 360X390X80	371	2.0	10.900
360	400 <small>-0.090 -0.126</small>	118	3.0	5.0	IR 360X400X118	373	2.5	22.000
380	415 <small>-0.080 -0.120</small>	100	2.1	5.0	IR 380X415X100	391	2.0	18.500
380	430 <small>-0.080 -0.120</small>	140	4.0	5.0	IR 380X430X140	396	3.0	35.000
400	450 <small>-0.080 -0.120</small>	140	4.0	5.0	IR 400X450X140	416	3.0	36.500
420	470 <small>-0.105 -0.145</small>	140	4.0	5.0	IR 420X470X140	436	3.0	38.200
440	490 <small>-0.105 -0.145</small>	160	4.0	5.0	IR 440X490X160	456	3.0	46.500

Notes: 1) The tolerance for this dimension provides regular clearance when an inner ring is combined with a needle roller bearing that lacks an inner ring.
2) These values are the allowable minimum dimensions of the chamfer dimension *r*.



ONE-WAY CLUTCHES

1. Types and designs

NIKO Series HF one-way clutches have an outer ring formed by precision drawing of thin steel plate, and are capable of a clutching function only. In order to carry a radial load and rotate smoothly, a one-way clutch must have bearings on both sides.

NIKO Engineering.

All of **NIKO**'s series HF one-way clutches use a polyamide resin cage that supports a leaf spring. The leaf spring in turn forces the needle rollers to the wedge section formed between the outer ring cam way and the shaft

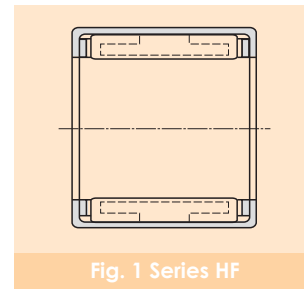

Fig. 1 Series HF

2. Interpreting clutch numbers

Clutch numbers of **NIKO** one-way clutches comprise a series number and dimension code.

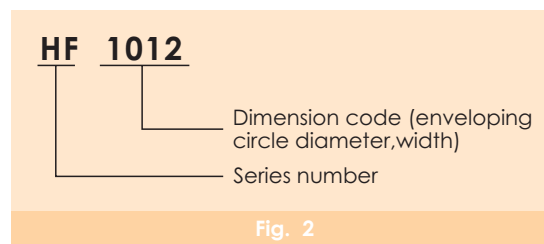

Fig. 2

3. Lubrication

Oil is the best lubrication for **NIKO** one-way clutches. However, they are supplied prefilled with adequate grease, as they are often grease-lubricated. Under normal operating conditions, this grease does not need replenishment. Note, however, that excessive grease can inhibit reliable clutch operation.

4. Mounting practices

Using a press-fit mandrel is convenient when assembling one-way clutch as illustrated in Fig.7. With series HF be sure to press-fit the clutch with its inscription side placed onto the shoulder on the mandrel. With series NHF, it is important to press-fit the clutch by using a special tool that presses the outer ring without pressing the oil retaining bearing. When assembling, be sure not to pry the outer ring or directly hit the outer ring with a hammer. Be sure place the appropriate tool on the face of the outer ring when press-fitting the clutch. When mass-producing clutches with a press, using a mandrel equipped with an O-ring facilitates insertion of the one-way clutch by keeping it from falling out. Turning the shaft in the direction in which the clutch slips facilitates the assembly. If this can't be done, providing a tapered guide (chamfered) on the shaft end will also facilitate assembly.

Transmission direction (direction of engagement)

The clutch is engaged when the outer ring (housing) is turned relative to the shaft in the direction indicated by the arrow mark.

With the series HF clutch, the mark is on the rib of the outer ring.

**ONE-WAY CLUTCH MINIATURE TYPE
SERIES HF**

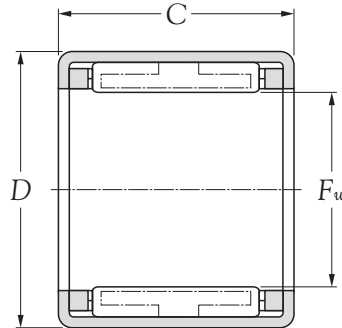

Boundary dimensions			Torque capacity Md		Part number by radial load		Bearing numbers	Mass kg (approx.)
<i>F_w</i>	mm		N · m	kgf · m	needle roller bearing	oil retaining bearing		
	<i>D</i>	<i>C</i>						
6	10	12	1.76	0.18	HK 0609 T2	B-S 6-22	HF 0612	0.0030
8	12	12	3.15	0.32	HK 0810	B-S 8-25	HF 0812	0.0035
10	14	12	5.30	0.54	HK 1010	B-S 10-21	HF 1012	0.0040
12	18	16	12.20	1.24	HK 1212	B-S 12-32	HF 1216	0.0116
14	20	16	17.30	1.76	HK 1412	B-S 14-13	HF 1416	0.0130
16	22	16	20.50	2.09	HK 1612	B-S 16-13	HF 1616	0.0140
18	24	16	24.10	2.46	HK 1812	B-S 18-8	HF 1816	0.0155
20	26	16	28.50	2.91	HK 2012	B-S 20-19	HF 2016	0.0170
25	32	20	66.00	6.73	HK 2512	B-S 25-11	HF 2520	0.0309
30	37	20	90.00	9.18	HK 3012	B-S 30-19	HF 3020	0.0360
35	42	20	121.00	12.30	HK 3512	B-S 35-7	HF 3520	0.0400

DRAWN CUP NEEDLE CLUTCH
SERIES HFL

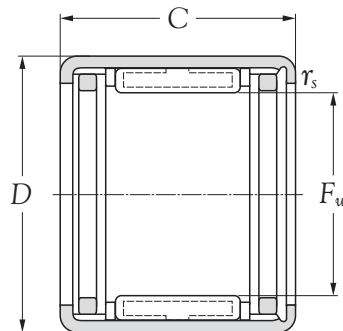

Boundary dimensions			Basic load ratings		Limiting speed		Rotation torque	Bearing numbers
mm			dynamic	static	rpm		Nm	
F_w	D	C	C_r	C_{or}	n	nI^{**}		
4	8	8	1,270	1,740	34,000	14,000	0.34	HFL 0408
6	10	15	1,650	2,030	23,000	13,000	1.76	HFL 0615
8	12	20	4,050	4,150	17,000	12,000	3.15	HFL 0822
10	14	22	4,300	4,650	14,000	11,000	5.30	HFL 1022
12	18	26	6,300	6,500	11,000	8,000	12.20	HFL 1226
14	20	26	6,300	6,500	9,500	8,000	17.30	HFL 1426
16	22	26	7,300	8,400	8,500	7,500	20.50	HFL 1626
18	24	26	8,200	10,300	7,500	7,500	24.10	HFL 1826
20	26	26	8,300	10,400	7,000	6,500	28.50	HFL 2026
25	32	30	10,900	14,100	5,500	5,500	66.00	HFL 2530
30	37	30	12,600	17,600	4,500	4,500	90.00	HFL 3030
35	42	30	13,000	19,300	3,900	3,900	121.00	HFL 3530

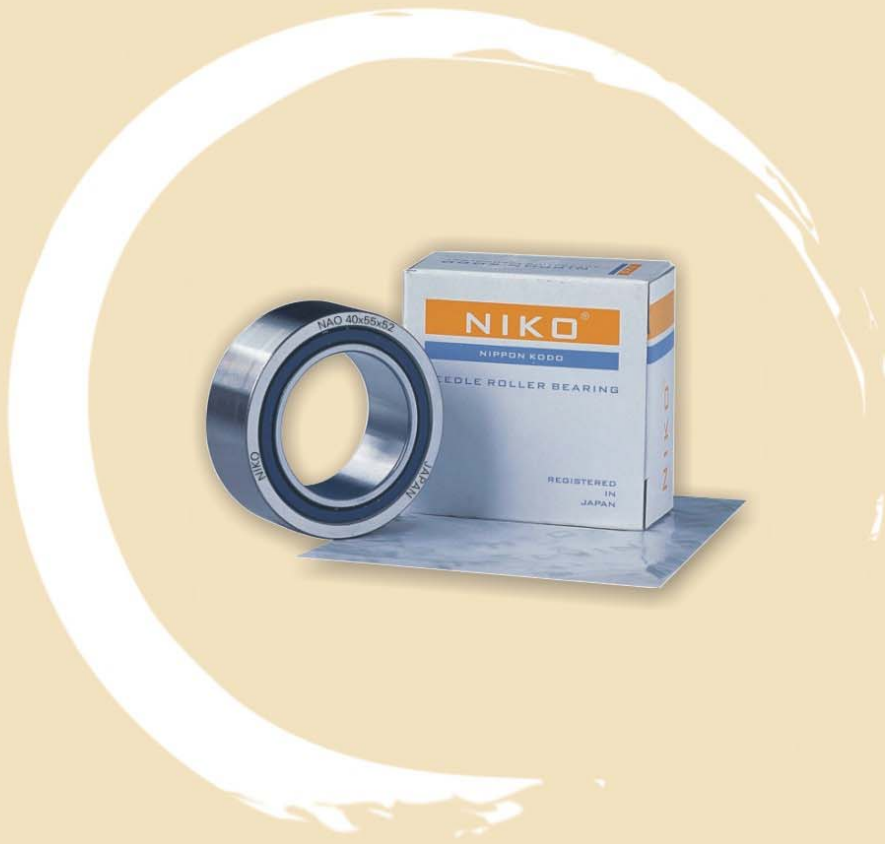

MACHINED RING NEEDLE ROLLER BEARINGS, SEPARABLE

1. Types and designs

The available **NIKO** Machined Ring Needle Roller Bearings, Separable, include the series RNAO (without inner ring) and series NAO (with inner ring).

The cage used for **NIKO** Machined Ring Needle Roller Bearings, Separable, is usually a machined ring type. However, cages of molded polyamide reinforced with glass fiber or carbon fiber (suffix T2) may be used. The T2 cage features a maximum allowable operating temperature of 120°C and maximum allowable continuous operating temperature of 100°C.

2. Interpreting bearing numbers

The bearing numbers of **NIKO** Machined Ring Needle Roller Bearings, Separable, comprise a series number (RNAO, NAO), dimension code (inscribed enveloping circle diameter or bore diameter X outside diameter X width), and suffix (Fig. 1~3).

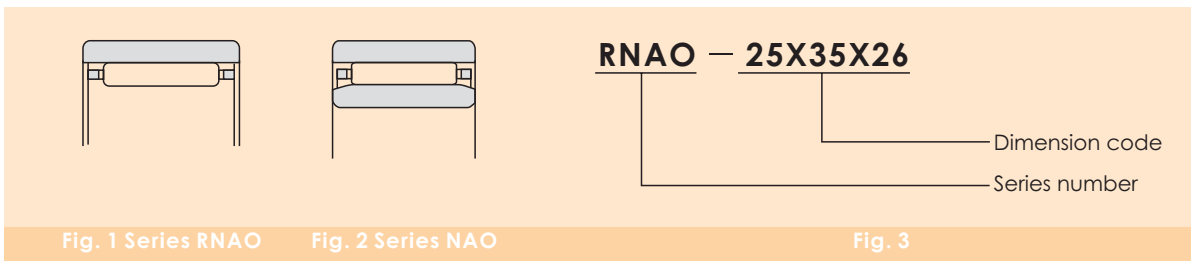

MACHINED-RING NEEDLE ROLLER BEARINGS. SEPARABLE
SERIES RNAO

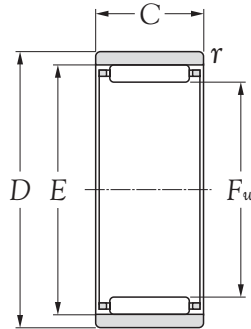

Boundary dimensions					Basic load ratings				Bearing numbers	
mm					dynamic	static	dynamic	static		
F_w	D	C	$r_s \text{ min}^{1)}$	E	N	C_{or}	kgf	C_{or}		
					C_r	C_{or}	C_r	C_{or}		
5	^{+0.018} / _{+0.010}	10	8.0	0.15	8	2,640	2,190	269	224	RNAO 5X10X8
6	^{+0.018} / _{+0.010}	13	8.0	0.30	9	2,660	2,280	272	233	RNAO 6X13X8
7	^{+0.022} / _{+0.013}	14	8.0	0.30	10	2,670	2,350	272	239	RNAO 7X14X8
8	^{+0.022} / _{+0.013}	15	10.0	0.30	11	4,000	4,100	410	420	RNAO 8X15X10
10	^{+0.022} / _{+0.013}	17	10.0	0.30	13	4,550	5,100	460	520	RNAO 10X17X10
10	^{+0.022} / _{+0.013}	20	12.0	0.30	16	7,100	5,950	720	610	RNAO 10X20X12
12	^{+0.027} / _{+0.016}	19	13.5	0.30	15	6,000	7,700	615	785	RNAO 12X19X13.5
12	^{+0.027} / _{+0.016}	22	12.0	0.30	18	8,650	8,000	880	815	RNAO 12X22X12
14	^{+0.027} / _{+0.016}	22	13.0	0.30	18	8,300	10,100	845	1,030	RNAO 14X22X13
14	^{+0.027} / _{+0.016}	26	12.0	0.30	20	9,350	9,150	955	930	RNAO 14X26X12
15	^{+0.027} / _{+0.016}	23	13.0	0.30	19	8,250	10,200	840	1,040	RNAO 15X23X13
16	^{+0.027} / _{+0.016}	24	13.0	0.30	20	9,050	11,800	925	1,200	RNAO 16X24X13
16	^{+0.027} / _{+0.016}	28	12.0	0.30	22	11,700	12,500	1,190	1,280	RNAO 16X28X12
17	^{+0.027} / _{+0.016}	25	13.0	0.30	21	9,400	12,600	960	1,280	RNAO 17X25X13
18	^{+0.027} / _{+0.016}	26	13.0	0.30	22	8,900	11,900	910	1,210	RNAO 18X26X13
18	^{+0.027} / _{+0.016}	30	12.0	0.30	24	12,300	13,800	1,250	1,410	RNAO 18X30X12
20	^{+0.033} / _{+0.020}	28	13.0	0.30	24	10,000	14,300	1,020	1,460	RNAO 20X28X13
20	^{+0.033} / _{+0.020}	32	12.0	0.30	26	12,900	15,100	1,320	1,540	RNAO 20X32 X12
22	^{+0.033} / _{+0.020}	30	13.0	0.30	26	10,200	15,200	1,040	1,550	RNAO 22X30X13
22	^{+0.033} / _{+0.020}	35	16.0	0.30	29	18,700	22,700	1,910	2,310	RNAO 22X35X16
25	^{+0.033} / _{+0.020}	35	17.0	0.30	29	14,200	24,000	1,450	2,450	RNAO 25X35X17
25	^{+0.033} / _{+0.020}	37	16.0	0.30	32	19,500	24,700	1,990	2,520	RNAO 25X37X16
26	^{+0.033} / _{+0.020}	39	13.0	0.30	30	11,800	19,200	1,200	1,960	RNAO 26X39X13
28	^{+0.033} / _{+0.020}	40	16.0	0.30	35	21,200	28,400	2,160	2,900	RNAO 28X40X16
30	^{+0.033} / _{+0.020}	40	17.0	0.30	35	19,400	32,500	1,970	3,350	RNAO 30X40X17
30	^{+0.033} / _{+0.020}	42	16.0	0.30	37	21,900	30,500	2,230	3,100	RNAO 30X42X16
32	^{+0.041} / _{+0.025}	42	13.0	0.30	37	14,500	23,000	1,480	2,350	RNAO 32X42X13
35	^{+0.041} / _{+0.025}	45	13.0	0.30	40	15,200	25,100	1,550	2,560	RNAO 35X45X13

Notes: 1) These values are the allowable minimum dimensions of the chamfer dimension r .

**MACHINED-RING NEEDLE ROLLER BEARINGS. SEPARABLE
SERIES RNAO**

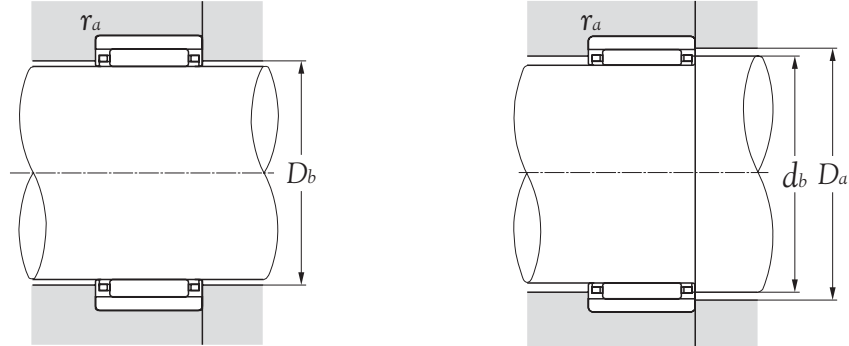

Abutment dimensions				Limiting speeds rpm		Bearing numbers	Mass kg (approx.)
<i>Db</i> min	<i>Da</i> max	<i>db</i> min	<i>ra</i> max	grease	oil		
7.7	8.8	5.3	0.15	27,000	40,000	RNAO 5X10X8	0.003
8.7	11.0	6.3	0.30	25,000	37,000	RNAO 6X13X8	0.006
9.7	12.0	7.3	0.30	23,000	34,000	RNAO 7X14X8	0.006
10.7	13.0	8.3	0.30	21,000	32,000	RNAO 8X15X10	0.008
12.7	15.0	10.3	0.30	19,000	28,000	RNAO 10X17X10	0.010
15.7	18.0	10.3	0.30	19,000	28,000	RNAO 10X20X12	0.018
14.7	17.0	12.3	0.30	17,000	26,000	RNAO 12X19X13.5	0.015
17.6	20.0	12.3	0.30	17,000	26,000	RNAO 12X22X12	0.019
17.6	20.0	14.4	0.30	16,000	24,000	RNAO 14X22X13	0.018
19.6	24.0	14.4	0.30	16,000	24,000	RNAO 14X26X12	0.029
18.6	21.0	15.4	0.30	15,000	23,000	RNAO 15X23X13	0.020
19.6	22.0	16.4	0.30	15,000	23,000	RNAO 16X24X13	0.021
21.6	26.0	16.4	0.30	15,000	23,000	RNAO 16X28X12	0.032
20.6	23.0	17.4	0.30	15,000	22,000	RNAO 17X25X13	0.022
21.6	24.0	18.4	0.30	14,000	21,000	RNAO 18X26X13	0.022
23.6	28.0	18.4	0.30	14,000	21,000	RNAO 18X30X12	0.035
23.6	26.0	20.4	0.30	13,000	20,000	RNAO 20X28X13	0.025
25.6	30.0	20.4	0.30	13,000	20,000	RNAO 20X32 X12	0.038
25.6	28.0	22.4	0.30	12,000	18,000	RNAO 22X30X13	0.027
28.4	33.0	22.4	0.30	12,000	18,000	RNAO 22X35X16	0.059
28.4	33.0	25.6	0.30	11,000	16,000	RNAO 25X35X17	0.053
31.4	35.0	25.6	0.30	11,000	16,000	RNAO 25X37X16	0.060
29.4	37.0	26.6	0.30	10,000	15,000	RNAO 26X39X13	0.060
34.4	38.0	28.6	0.30	9,500	14,000	RNAO 28X40X16	0.061
34.4	38.0	30.6	0.30	9,000	13,000	RNAO 30X40X17	0.060
36.4	40.0	30.6	0.30	9,000	13,000	RNAO 30X42X16	0.069
36.4	40.0	32.6	0.30	8,500	13,000	RNAO 32X42X13	0.049
39.4	43.0	35.6	0.30	7,500	11,000	RNAO 35X45X13	0.053

MACHINED-RING NEEDLE ROLLER BEARINGS. SEPARABLE
SERIES RNAO

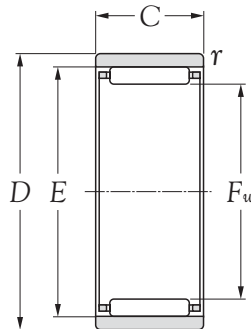

Boundary dimensions					Basic load ratings				Bearing numbers
mm					dynamic	static	dynamic	static	
F_w	D	C	$r_s \text{ min}^{1)}$	E	N	C_{or}	C_r	kgf	
					C_r	C_{or}	C_r	C_{or}	
35 ^{+0.041} / _{+0.025}	45	17	0.3	40	20,000	36,000	2,040	3,650	RNAO 35X45X17
35 ^{+0.041} / _{+0.025}	47	16	0.3	42	24,100	36,000	2,450	3,650	RNAO 35X47X16
35 ^{+0.041} / _{+0.025}	47	18	0.3	42	24,700	37,000	2,510	3,750	RNAO 35X47X18
37 ^{+0.041} / _{+0.025}	47	13	0.3	42	15,900	27,100	1,620	2,770	RNAO 37X47X13
37 ^{+0.041} / _{+0.025}	52	18	0.3	44	26,300	41,000	2,680	4,150	RNAO 37X52X18
40 ^{+0.041} / _{+0.025}	50	17	0.3	45	21,800	41,500	2,220	4,250	RNAO 40X50X17
40 ^{+0.041} / _{+0.025}	55	20	0.3	47	31,000	51,500	3,150	5,250	RNAO 40X55X20
45 ^{+0.041} / _{+0.025}	55	17	0.3	50	22,300	44,500	2,280	4,550	RNAO 45X55X17
45 ^{+0.041} / _{+0.025}	62	20	0.3	53	36,000	59,000	3,650	6,000	RNAO 45X62X20
50 ^{+0.041} / _{+0.025}	62	20	0.3	55	27,900	62,000	2,850	6,300	RNAO 50X62X20
50 ^{+0.041} / _{+0.025}	65	20	0.3	58	38,500	67,500	3,950	6,850	RNAO 50X65X20
55 ^{+0.049} / _{+0.060}	68	20	0.6	60	28,800	66,500	2,940	6,750	RNAO 55X68X20
55 ^{+0.049} / _{+0.030}	68	25	0.6	63	50,500	97,500	5,150	9,950	RNAO 55X68X25
55 ^{+0.049} / _{+0.030}	72	20	0.6	63	39,000	70,000	3,950	7,100	RNAO 55X72X20
60 ^{+0.049} / _{+0.030}	78	20	1.0	68	40,000	75,000	4,100	7,650	RNAO 60X78X20
65 ^{+0.049} / _{+0.030}	85	30	1.0	73	61,000	132,000	6,200	13,400	RNAO 65X85X30
70 ^{+0.049} / _{+0.030}	90	30	1.0	78	65,500	149,000	6,700	15,200	RNAO 70X90X30
75 ^{+0.049} / _{+0.030}	95	30	1.0	83	67,500	157,000	6,850	16,100	RNAO 75X95X30
80 ^{+0.049} / _{+0.030}	95	30	1.0	86	57,000	159,000	5,800	16,200	RNAO 80X95X30
80 ^{+0.049} / _{+0.030}	100	30	1.0	88	69,000	166,000	7,050	17,000	RNAO 80X100X30
85 ^{+0.058} / _{+0.036}	105	25	1.0	93	61,500	146,000	6,250	14,900	RNAO 85X105X25
85 ^{+0.058} / _{+0.036}	105	30	1.0	93	71,000	175,000	7,200	17,900	RNAO 85X105X30
90 ^{+0.058} / _{+0.036}	105	26	1.0	98	64,000	157,000	6,550	16,000	RNAO 90X105X26
90 ^{+0.058} / _{+0.036}	110	30	1.0	98	72,500	184,000	7,400	18,800	RNAO 90X110X30
95 ^{+0.058} / _{+0.036}	115	30	1.0	103	74,000	193,000	7,550	19,600	RNAO 95X115X30
100 ^{+0.058} / _{+0.035}	120	30	1.0	108	76,000	201,000	7,700	20,500	RNAO 100X120X30

Notes: 1) These values are the allowable minimum dimensions of the chamfer dimension r .

**MACHINED-RING NEEDLE ROLLER BEARINGS. SEPARABLE
SERIES RNAO**

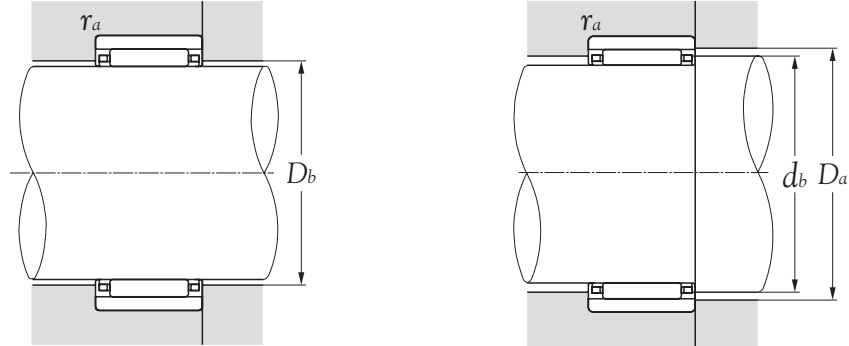

Abutment dimensions				Limiting speeds rpm		Bearing numbers	Mass kg (approx.)
<i>Db</i> min	<i>Da</i> max	<i>db</i> min	<i>ra</i> max	grease	oil		
39.4	43	35.6	0.3	7,500	11,000	RNAO 35X45X17	0.069
41.4	45	35.6	0.3	7,500	11,000	RNAO 35X47X16	0.078
41.4	45	35.6	0.3	7,500	11,000	RNAO 35X47X18	0.089
41.4	45	37.6	0.3	7,000	11,000	RNAO 37X47X13	0.056
43.4	50	37.6	0.3	7,000	11,000	RNAO 37X52X18	0.125
44.4	48	40.6	0.3	6,500	10,000	RNAO 40X50X17	0.074
46.2	53	40.6	0.3	6,500	10,000	RNAO 40X55X20	0.145
49.2	53	45.6	0.3	6,000	9,000	RNAO 45X55X17	0.083
52.2	60	45.6	0.3	6,000	9,000	RNAO 45X62X20	0.175
54.2	60	50.6	0.3	5,500	8,000	RNAO 50X62X20	0.140
57.2	63	50.6	0.3	5,500	8,000	RNAO 50X65X20	0.168
59.4	64	55.8	0.6	4,800	7,500	RNAO 55X68X20	0.166
62.4	64	55.8	0.6	4,800	7,500	RNAO 55X68X25	0.200
62.4	68	55.8	0.6	4,800	7,500	RNAO 55X72X20	0.216
67.2	73	60.8	1.0	4,400	6,500	RNAO 60X78X20	0.255
72.2	80	66.0	1.0	4,100	6,000	RNAO 65X85X30	0.464
77.2	85	71.0	1.0	3,800	5,500	RNAO 70X90X30	0.199
82.2	90	76.0	1.0	3,600	5,500	RNAO 75X95X30	0.520
85.2	90	81.0	1.0	3,300	5,000	RNAO 80X95X30	0.405
87.2	95	81.0	1.0	3,300	5,000	RNAO 80X100X30	0.580
92.2	100	86.0	1.0	3,100	4,700	RNAO 85X105X25	0.459
92.2	100	86.0	1.0	3,100	4,700	RNAO 85X105X30	0.585
97.2	100	91.0	1.0	3,000	4,400	RNAO 90X105X26	0.373
97.2	105	91.0	1.0	3,000	4,400	RNAO 90X110X30	0.610
102.2	110	96.0	1.0	2,800	4,200	RNAO 95X115X30	0.640
107.2	115	101.0	1.0	2,700	4,000	RNAO 100X120X30	0.694

**MACHINED-RING NEEDLE ROLLER BEARINGS. SEPARABLE
SERIES NAO**

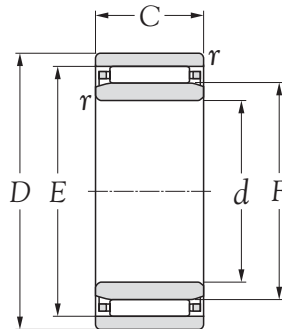

Boundary dimensions						Basic load ratings				Bearing numbers
mm						dynamic	static	dynamic	static	
<i>d</i>	<i>D</i>	<i>C</i>	<i>r</i> _{s min} ¹⁾	<i>F</i>	<i>E</i>	<i>C_r</i>	<i>C_{0r}</i>	<i>C_r</i>	<i>C_{0r}</i>	
						N		kgf		
6	17	10	0.3	10	13	4,550	5,100	460	520	NAO 6X17X10
7	20	12	0.3	10	16	7,100	5,950	720	610	NAO 7X20X12
9	22	12	0.3	12	18	8,650	8,000	880	815	NAO 9X22X12
10	22	13	0.3	14	18	8,300	10,100	845	1,030	NAO 10X22X13
10	26	12	0.3	14	20	9,350	9,150	955	930	NAO 10X26X12
12	24	13	0.3	16	20	9,050	11,800	925	1,200	NAO 12X24X13
12	28	12	0.3	16	22	11,700	12,500	1,190	1,280	NAO 12X28X12
15	28	13	0.3	20	24	10,000	14,300	1,020	1,460	NAO 15X28X13
15	32	12	0.3	20	26	12,900	15,100	1,320	1,540	NAO 15X32X12
17	30	13	0.3	22	26	10,200	15,200	1,040	1,550	NAO 17X30X13
17	35	16	0.3	22	29	18,700	22,700	1,910	2,310	NAO 17X35X16
20	35	17	0.3	25	29	14,200	24,000	1,450	2,450	NAO 20X35X17
20	37	16	0.3	25	32	19,500	24,700	1,990	2,520	NAO 20X37X16
25	40	17	0.3	30	35	19,400	32,500	1,970	3,350	NAO 25X40X17
25	42	16	0.3	30	37	21,900	30,500	2,230	3,100	NAO 25X42X16
29	42	13	0.3	32	37	14,500	23,000	1,480	2,350	NAO 29X42X13
30	45	13	0.3	35	40	15,200	25,100	1,550	2,560	NAO 30X45X13
30	45	17	0.3	35	40	20,000	36,000	2,040	3,650	NAO 30X45X17
30	47	16	0.3	35	42	24,100	36,000	2,450	3,650	NAO 30X47X16
30	47	18	0.3	35	42	24,700	37,000	2,510	3,750	NAO 30X47X18
30	52	18	0.3	37	44	26,300	41,000	2,680	4,150	NAO 30X52X18
33	47	13	0.3	37	42	15,900	27,100	1,620	2,770	NAO 33X47X13
35	50	17	0.3	40	45	21,800	41,500	2,220	4,250	NAO 35X50X17
35	55	20	0.3	40	47	31,000	51,500	3,150	5,250	NAO 35X55X20
40	55	17	0.3	45	50	22,300	44,500	2,280	4,550	NAO 40X55X17
40	62	20	0.3	45	53	36,000	59,000	3,650	6,000	NAO 40X62X20
40	65	20	0.3	50	58	38,500	67,500	3,950	6,850	NAO 40X65X20
45	62	20	0.3	50	55	27,900	62,000	2,850	6,300	NAO 45X62X20

Notes: 1) These values are the allowable minimum dimensions of the chamfer dimension *r*.

MACHINED-RING NEEDLE ROLLER BEARINGS. SEPARABLE
SERIES NAO

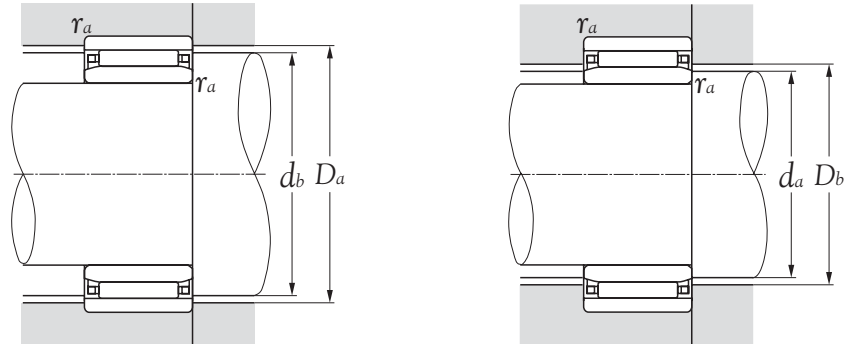

Abutment dimensions					Limiting speeds rpm		Bearing numbers	Mass kg (approx.)
d_a min	d_b	D_a max	D_b	r_a min	grease	oil		
8	12.7	15	10.3	0.3	19,000	28,000	NAO 6X17X10	0.014
9	15.7	18	10.3	0.3	19,000	28,000	NAO 7X20X12	0.022
11	17.6	20	12.3	0.3	17,000	26,000	NAO 9X22X12	0.024
12	17.6	20	14.4	0.3	16,000	24,000	NAO 10X22X13	0.026
12	19.6	24	14.4	0.3	16,000	24,000	NAO 10X26X12	0.036
14	19.6	22	16.4	0.3	15,000	23,000	NAO 12X24X13	0.030
14	21.6	26	16.4	0.3	15,000	23,000	NAO 12X28X12	0.040
17	23.6	26	20.4	0.3	13,000	20,000	NAO 15X28X13	0.029
17	25.6	30	20.4	0.3	13,000	20,000	NAO 15X32X12	0.050
19	25.6	28	22.4	0.3	12,000	18,000	NAO 17X30X13	0.042
19	28.4	33	22.4	0.3	12,000	18,000	NAO 17X35X16	0.078
22	28.4	33	25.6	0.3	11,000	16,000	NAO 20X35X17	0.076
22	31.4	35	25.6	0.3	11,000	16,000	NAO 20X37X16	0.082
27	34.4	38	30.6	0.3	9,000	13,000	NAO 25X40X17	0.088
27	36.4	40	30.6	0.3	9,000	13,000	NAO 25X42X16	0.086
31	36.4	40	32.6	0.3	8,500	13,000	NAO 29X42X13	0.062
32	39.4	43	35.6	0.3	7,500	11,000	NAO 30X45X13	0.077
32	39.4	43	35.6	0.3	7,500	11,000	NAO 30X45X17	0.102
32	41.4	45	35.6	0.3	7,500	11,000	NAO 30X47X16	0.109
32	41.4	45	35.6	0.3	7,500	11,000	NAO 30X47X18	0.119
32	43.4	50	37.6	0.3	7,000	11,000	NAO 30X52X18	0.177
35	41.4	45	37.6	0.3	7,000	11,000	NAO 33X47X13	0.085
37	44.4	48	40.6	0.3	6,500	10,000	NAO 35X50X17	0.113
37	46.2	53	40.6	0.3	6,500	10,000	NAO 35X55X20	0.190
42	49.2	53	45.6	0.3	6,000	9,000	NAO 40X55X17	0.127
42	52.2	60	45.6	0.3	6,000	9,000	NAO 40X62X20	0.230
42	57.2	63	50.6	0.3	5,500	9,000	NAO 40X65X20	0.279
47	54.2	60	50.6	0.3	5,500	8,000	NAO 45X62X20	0.192

**MACHINED-RING NEEDLE ROLLER BEARINGS. SEPARABLE
SERIES NAO**

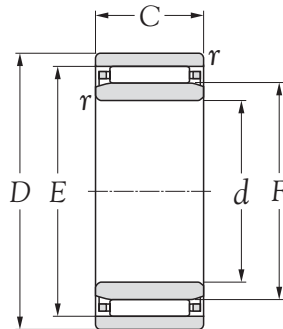

Boundary dimensions						Basic load ratings				Bearing numbers
mm						dynamic	static	dynamic	static	
d	D	C	$r_s \text{ min}^1$	F	E	C_r	C_{or}	C_r	C_{or}	
45	72	20	0.6	55	63	39,000	70,000	3,950	7,100	NAO 45X72X20
50	68	20	0.6	55	60	28,800	66,500	2,940	6,750	NAO 50X68X20
50	78	20	1.0	60	68	40,000	75,000	4,100	7,650	NAO 50X78X20
55	85	30	1.0	65	73	61,000	132,000	6,200	13,400	NAO 55X85X30
60	90	30	1.0	70	78	65,500	149,000	6,700	15,200	NAO 60X90X30
65	95	30	1.0	75	83	67,500	157,000	6,850	16,100	NAO 65X95X30
70	95	30	1.0	80	86	57,000	159,000	5,800	16,200	NAO 70X95X30
70	100	30	1.0	80	88	69,000	166,000	7,050	17,000	NAO 70X100X30
75	105	25	1.0	85	93	61,500	146,000	6,250	14,900	NAO 75X105X25
75	105	30	1.0	85	93	71,000	175,000	7,200	17,900	NAO 75X105X30
80	110	30	1.0	90	98	72,500	184,000	7,400	18,800	NAO 80X110X30
85	115	30	1.0	95	103	74,000	193,000	7,550	19,600	NAO 85X115X30
90	120	30	1.0	100	108	76,000	201,000	7,700	20,500	NAO 90X120X30

Notes: 1) These values are the allowable minimum dimensions of the chamfer dimension r .

**MACHINED-RING NEEDLE ROLLER BEARINGS. SEPARABLE
SERIES NAO**

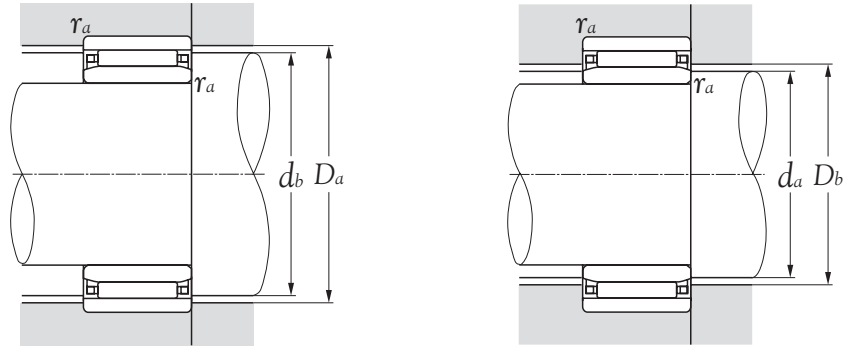

Abutment dimensions					Limiting speeds rpm		Bearing numbers	Mass kg (approx.)
d_a min	d_b	D_a max	D_b	r_{as} min	grease	oil		
49	62.4	68	55.8	0.6	4,800	7,500	NAO 45X72X20	0.335
54	59.4	64	55.8	0.6	4,800	7,500	NAO 50X68X20	0.230
55	67.2	73	60.8	1.0	4,400	6,500	NAO 50X78X20	0.410
60	72.2	80	66.0	1.0	4,100	6,000	NAO 55X85X30	0.680
65	77.2	85	71.0	1.0	3,800	5,500	NAO 60X90X30	0.720
70	82.2	90	76.0	1.0	3,600	5,500	NAO 65X95X30	0.770
75	85.2	90	81.0	1.0	3,300	5,000	NAO 70X95X30	0.675
75	87.2	95	81.0	1.0	3,300	5,000	NAO 70X100X30	0.850
80	92.2	100	86.0	1.0	3,100	4,700	NAO 75X105X25	0.700
80	92.2	100	86.0	1.0	3,100	4,700	NAO 75X105X30	0.880
85	97.2	105	91.0	1.0	3,000	4,400	NAO 80X110X30	0.920
90	102.2	110	96.0	1.0	2,800	4,200	NAO 85X115X30	0.960
95	107.2	115	101.0	1.0	2,700	4,000	NAO 90X120X30	1.040

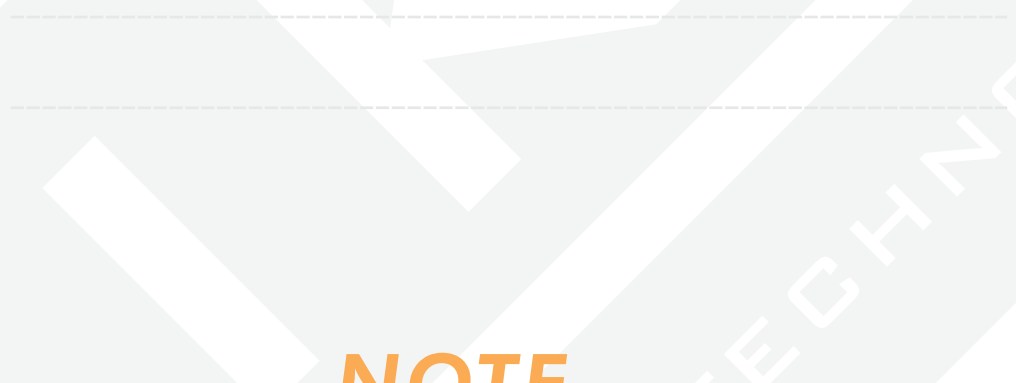

NOTE

AUTOMATION TECHNOLOGY

1. Seals

Seals for needle roller bearings are special seals having a low cross-sectional height to accommodate needle roller bearings. These steel plate-reinforced synthetic rubber contact seals should be used within a standard operating temperature range of -25 to 120°C; the seals should not be used in excess of 100°C for continuous operation. Consult **NIKO** Engineering if you are considering an application involving special operating conditions including operating temperature of 120°C or higher.

2. Seal types

Seals for needle roller bearings are available in the series G, which has a single lip, and the series GD, which has a double lip. For special operating conditions, such as an operating temperature exceeding 120°C, consult **NIKO** Engineering.

Where good seal seating and lubricating conditions are present, the maximum allowable peripheral velocity is 10m/s for the single-lip series G, and 6 m/s for the doublelip series GD.

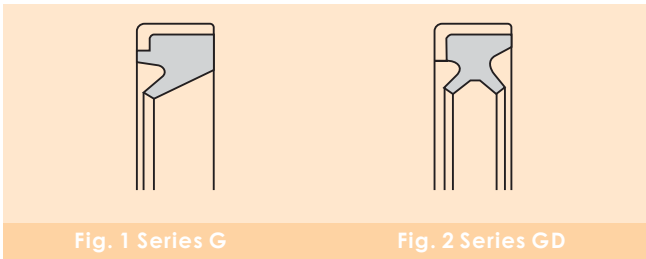

Fig. 1 Series G

Fig. 2 Series GD

3. Interpreting seal numbers

Seal numbers comprise a series number (G or GD) and a dimension code (inside diameter X outside diameter X width.)

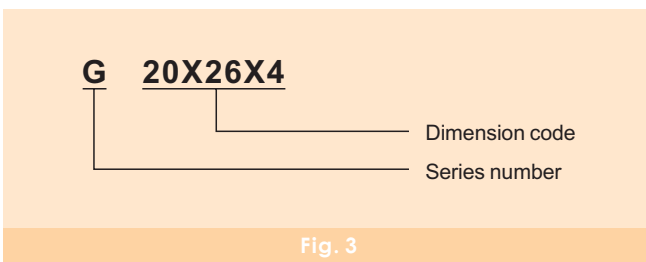

Fig. 3

4. Mounting practices

To achieve a reliable seal, the seal seating must be hardened and finish-ground. If the raceway surface of an inner ring is used as the seal seat, an extended inner ring should be used.

To prevent the seal lip and outside surface of the seal from being damaged during mounting, the shaft end or housing end should be tapered (Fig.4). If the shaft end lacks a taper or rounding, use of the mounting jig as shown in Fig.5 is recommended. Sufficient interference between the seal and housing will be obtained from an ordinary housing tolerance of G7 to R7.

To lubricate the lip, apply lubricant to the lip before mounting the seal.

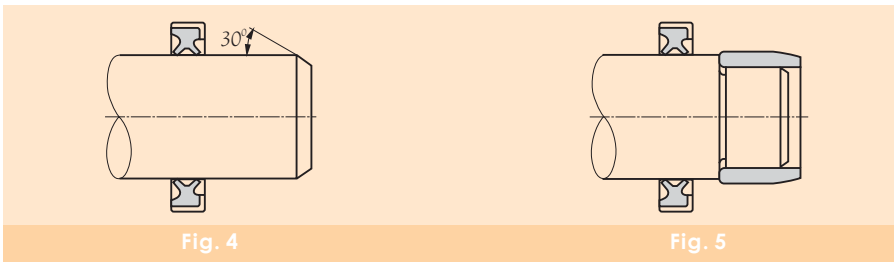

5. Typical seal applications

Fig. 6 to 8 illustrate typical designs of seals for needle roller bearings.

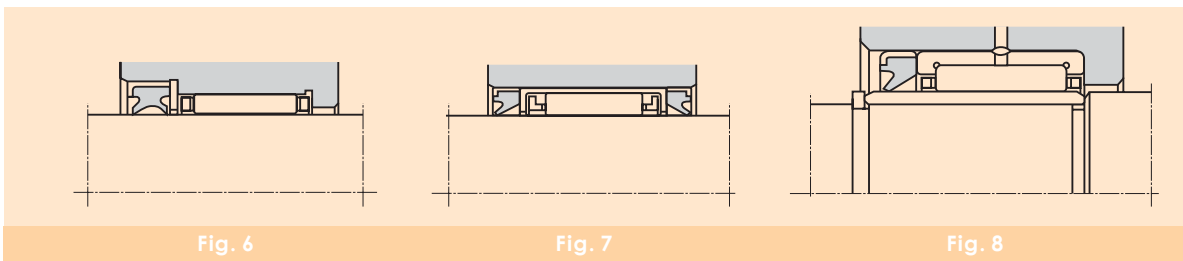

**SEALING RINGS
SERIES G, GD**

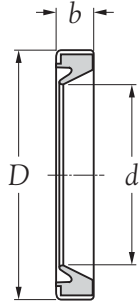

Type G

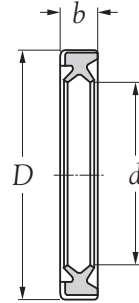

Type GD

Boundary dimensions			Bearing numbers		Mass	
<i>d</i>	mm <i>D</i> ¹⁾	<i>b</i> _{+0.2 0}	Type G	Type GD	X 10 ⁻³ kg	
					G	GD
4	8 ^{+0.081 +0.023}	2	G 4X8X2	-	0.18	-
5	9 ^{+0.081 +0.023}	2	G 5X9X3	-	0.19	-
5	10 ^{+0.081 +0.023}	2	G 5X10X2	-	0.22	-
6	10 ^{+0.081 +0.023}	2	G 6X10X2	-	0.21	-
6	12 ^{+0.098 +0.028}	2	G 6X12X2	-	0.38	-
7	11 ^{+0.098 +0.028}	2	G 7X11X2	-	0.25	-
7	14 ^{+0.098 +0.028}	2	G 7X14X2	-	0.52	-
8	12 ^{+0.098 +0.028}	3	G 8X12X3	-	0.41	-
8	15 ^{+0.098 +0.028}	3	G 8X15X3	-	0.74	-
9	13 ^{+0.098 +0.028}	3	G 9X13X3	-	0.44	-
9	16 ^{+0.098 +0.028}	3	G 9X16X3	-	0.69	-
10	14 ^{+0.098 +0.028}	3	G 10X14X3	-	0.50	-
10	17 ^{+0.098 +0.028}	3	G 10X17X3	-	0.87	-
12	16 ^{+0.098 +0.028}	3	G 12X16X3	-	0.56	-
12	18 ^{+0.098 +0.028}	3	G 12X18X3	-	0.86	-
12	19 ^{+0.119 +0.035}	3	G 12X19X3	-	0.94	-
13	19 ^{+0.119 +0.035}	3	G 13X19X3	-	0.87	-
14	20 ^{+0.119 +0.035}	3	G 14X20X3	GD 14X20X3	0.96	0.99
14	21 ^{+0.119 +0.035}	3	G 14X21X3	GD 14X21X3	1.10	1.10
14	22 ^{+0.119 +0.035}	3	G 14X22X3	GD 14X22X3	1.30	1.30
15	21 ^{+0.119 +0.035}	3	G 15X21X3	GD 15X21X3	1.00	1.00
15	23 ^{+0.119 +0.035}	3	G 15X23X3	GD 15X23X3	1.30	1.30
16	22 ^{+0.119 +0.035}	3	G 16X22X3	GD 16X22X3	1.30	1.10
16	24 ^{+0.119 +0.035}	3	G 16X24X3	GD 16X24X3	1.30	1.30
16	25 ^{+0.119 +0.035}	3	G 16X25X3	GD 16X25X3	1.60	1.60
17	23 ^{+0.119 +0.035}	3	G 17X23X3	GD 17X23X3	1.30	1.10
17	25 ^{+0.119 +0.035}	3	G 17X25X3	GD 17X25X3	1.50	1.40
18	24 ^{+0.119 +0.035}	3	G 18X24X3	GD 18X24X3	1.20	1.20

Notes: 1) The tolerance of the outside diameter is an average of two measurements taken at equally spaced points on the outside surface.

**SEALING RINGS
SERIES G, GD**

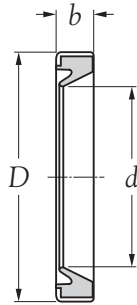

Type G

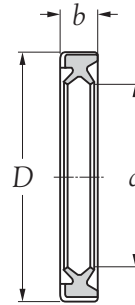

Type GD

Boundary dimensions			Bearing numbers		Mass	
<i>d</i>	mm <i>D</i> ¹⁾	<i>b</i> _{+0.2 0}	Type G	Type GD	X 10 ⁻³ kg	
					G	GD
18	26 ^{+0.119 +0.035}	4	G 18X26X4	GD 18X26X4	1.8	1.8
19	27 ^{+0.119 +0.035}	4	G 19X27X4	GD 19X27X4	2.0	1.9
20	26 ^{+0.119 +0.035}	4	G 20X26X4	GD 20X26X4	1.8	1.8
20	28 ^{+0.119 +0.035}	4	G 20X28X4	GD 20X28X4	2.1	2.1
21	29 ^{+0.119 +0.035}	4	G 21X29X4	GD 21X29X4	2.2	2.1
22	28 ^{+0.119 +0.035}	4	G 22X28X3	GD 22X28X3	1.8	1.9
22	30 ^{+0.119 +0.035}	4	G 22X30X3	GD 22X30X3	2.2	2.3
24	32 ^{+0.143 +0.043}	4	G 24X32X4	GD 24X32X4	2.5	2.4
25	32 ^{+0.143 +0.043}	4	G 25X32X4	GD 25X32X4	2.3	2.2
25	33 ^{+0.143 +0.043}	4	G 25X33X4	GD 25X33X4	2.5	2.5
25	35 ^{+0.143 +0.043}	4	G 26X34X4	GD 26X34X4	2.6	2.6
26	34 ^{+0.143 +0.043}	4	G 28X35X4	GD 28X35X4	2.6	2.6
28	35 ^{+0.143 +0.043}	4	G 28X37X4	GD 28X37X4	2.4	2.5
28	37 ^{+0.143 +0.043}	4	G 28X37X4	GD 28X37X4	3.1	2.8
29	37 ^{+0.143 +0.043}	4	G 29X37X4	GD 29X37X4	2.7	2.7
29	38 ^{+0.143 +0.043}	4	G 29X38X4	GD 29X38X4	3.2	2.9
30	37 ^{+0.143 +0.043}	4	G 30X37X4	GD 30X37X4	2.7	2.6
30	40 ^{+0.143 +0.043}	4	G 30X40X4	GD 30X40X4	3.6	3.3
32	42 ^{+0.143 +0.043}	4	G 32X42X4	GD 32X42X4	3.7	3.9
32	45 ^{+0.143 +0.043}	4	G 32X45X4	GD 32X45X4	5.1	5.2
35	42 ^{+0.143 +0.043}	4	G 35X42X4	GD 35X42X4	3.0	2.9
35	45 ^{+0.143 +0.043}	4	G 35X45X4	GD 35X45X4	4.1	3.6
37	47 ^{+0.143 +0.043}	4	G 37X47X4	GD 37X47X4	4.0	3.8
38	48 ^{+0.143 +0.043}	4	G 38X48X4	GD 38X48X4	4.4	4.0
40	47 ^{+0.143 +0.043}	4	G 40X47X4	GD 40X47X4	3.3	3.5
40	50 ^{+0.143 +0.043}	4	G 40X50X4	GD 40X50X4	4.6	4.0
40	52 ^{+0.173 +0.053}	5	G 40X52X4	GD 40X52X4	4.8	4.7
42	52 ^{+0.173 +0.053}	4	G 42X52X4	GD 42X52X4	4.7	4.2

Notes: 1) The tolerance of the outside diameter is an average of two measurements taken at equally spaced points on the outside surface.

**SEALING RINGS
SERIES G, GD**

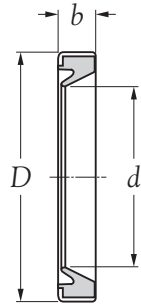

Type G

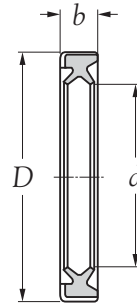

Type GD

Boundary dimensions			Bearing numbers		Mass	
<i>d</i>	mm <i>D</i> ¹⁾	<i>b</i> _{+0.2 0}	Type G	Type GD	X 10 ⁻³ kg	
					G	GD
43	53 ^{+0.173 +0.053}	4	G 43X53X4	GD 43X53X4	4.8	4.3
45	52 ^{+0.173 +0.053}	4	G 45X52X4	GD 45X52X4	3.8	3.8
45	55 ^{+0.173 +0.053}	4	G 45X55X4	GD 45X55X4	5.2	5.5
50	58 ^{+0.173 +0.053}	4	G 50X58X4	GD 50X58X4	4.5	5.2
50	62 ^{+0.173 +0.053}	4	G 650X62X5	GD 650X62X5	10.4	10.0

Notes: 1) The tolerance of the outside diameter is an average of two measurements taken at equally spaced points on the outside surface.

NIKO[®]

NIPPON KODO
AUTOMATION TECHNOLOGY

NIPPON KODO CO., LTD.
OSAKA-JAPAN



Brand Promise !