

NIKO[®]

NIPPON KODO
AUTOMATION TECHNOLOGY

LINEAR MOTION 2012



LINEAR MOTION 2012



BALL BUSHING		PAGES FOR REFER
		14 ~ 26
	SERIES LME..AS, ALL COMES WITH FIXING HOLES & GREASE HOLES	14 ~ 15
	LME..AS SERIES	
	PRECISION DESIGN, CLOSED TYPE, METRIC BOUNDARIES	16 ~ 17
	LME..UUOP AS SERIES	
	PRECISION DESIGN, CLOSED TYPE, METRIC BOUNDARIES	18 ~ 19
	LME..UUAJ AS SERIES	
	PRECISION DESIGN, ROUND FLANGE TYPE, METRIC BOUNDARIES	20 ~ 21
	LME-F SERIES	
	PRECISION DESIGN, SQUARE FLANGE TYPE, METRIC BOUNDARIES	22 ~ 23
	LME-K SERIES	
	SUPER BALL BUSHINGS, EUROPEAN STANDARD	24
	LMES SERIES	
	SUPER BALL BUSHINGS, EUROPEAN STANDARD	25
	LMES..OP SERIES	
	DRAWN SHELL DESIGN, METRIC BOUNDARIES	26
	KH SERIES, OPEN TYPES & PP	

ALUMINIUM HOUSINGS & COMPLETE UNITS		PAGES FOR REFER
		28 ~ 33
	FGWA ALUMINIUM HOUSINGS	28
	FGWA SERIES	
	SB ALUMINIUM HOUSINGS	29
	SB..AS, SB LME..UUAS SERIES	
	SO ALUMINIUM HOUSINGS	30
	SO..AS, SO LME..UUOP AS SERIES	
	S2B..N ALUMINIUM HOUSINGS	31
	S2B..N, S2B..N+LME SERIES	
	SBT ALUMINIUM HOUSINGS	32 ~ 33
	SBT..AS, SBT..AS+LME SERIES	

TRACK ROLLER BEARINGS		PAGES FOR REFER
		48 ~ 57
	SINGLE ROW OF BALLS TRACK ROLLERS WITH CYLINDRICAL AND CROWNED OD LR..NPP, LR..RRU SERIES	48
	DOUBLE ROWS OF BALLS TRACK ROLLERS WITH CROWNED OD LR 52..NPPU, LR 52..KDD SERIES	49
	DOUBLE ROWS OF BALLS TRACK ROLLERS WITH CROWNED OD LR 53..NPPU SERIES	50
	GOTHIC ARCH GROOVE PROFILE TRACK ROLLERS LFR..ZZ, LFR..2RS SERIES	51
	MOUNTING BOLTS AND STUDS RC.., RE.., RC..A1, RE..A1 SERIES	52
	"V" GROOVE PROFILE TRACK ROLLERS RV.. SERIES	53
	"W" GROOVE PROFILE TRACK ROLLERS RM..ZZ, RM..2RS SERIES	54
	"V" GROOVE PROFILE TRACK ROLLERS WITH INTEGRAL STUD RV..C, RV..E SERIES	55
	GOTHIC ARCH PROFILE TRACK ROLLERS WITH INTEGRAL STUD RPC.., RPE.. SERIES	56
	SUPPORT ROLLERS WITH INTEGRAL STUD AND CYLINDRICAL OD RA..A SERIES	57



NOTE



AUTOMATION TECHNOLOGY





**LINEAR MOTION
TECHNICAL TABLES**

TECHNICAL INFORMATION		PAGES FOR REFER
		7 ~ 12
1.	RECIRCULATING BALL BEARING, DRAWN SHELL DESIGN, COMPACT TYPE, SERIES KH	7
2.	LINEAR RECIRCULATING BALL BEARING PRECISION SERIES TYPE LME	7 ~ 8
3.	LINEAR RECIRCULATING BALL BEARING PRECISION SERIES TYPE LME	8 ~ 9
4.	LOAD RATINGS	9 ~ 11
5.	STATIC SAFETY FACTOR	11
6.	FRICTION	12
7.	OPERATING TEMPERATURE	12

1. Recirculating Ball Bearing, drawn shell design, compact type, series KH

The Linear Recirculating Ball Bearings KH are composed of a steel drawn shell, made of case hardened steel, a retainer made from engineered resin and precision balls. The drawn shell has pockets designed to allow the recirculation of the balls. This bearing type can only be used for linear movement and does not allow rotational movements.

1.1 Seals

The linear bearings of KH type are available in two different variants.

Without seals: KH

With contact seals: KH..PP

The seals have the dual function to prevent ingress of contaminants and the retention of lubricants in the bearings.

1.2 Lubrication

Linear bearings type KH are supplied coated with rust inhibiting oil. Linear bearings type KH..PP are supplied packaged with lithium soap grease.

1.3 Mounting tolerances

The table below shows the tolerances to be used for a proper bearing installation. They insure a precise and smooth motion.

1.4 Assembly

Linear bearings type KH are assembled with a light press fit. This insures not only the retention of the bearing but also the proper rounding of the unit. A proper fitting should be performed with the help of a mounting arbor as shown in Fig. 1.

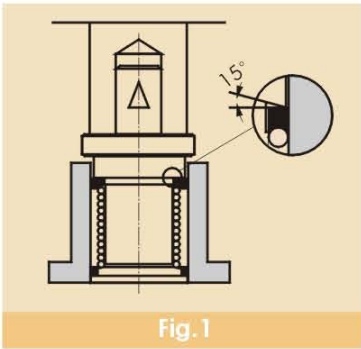

Table 1.1 Recommended mounting tolerances

Housing material	General application		Vertical operation Precision application	
	Housing tolerance	Shaft tolerance	Housing tolerance	Shaft tolerance
Steel/cast iron	H7	h6	H6	i5
Aluminium/alloy	K7	h6	K6	i5

2. Linear Recirculating Ball Bearing precision series type LME

NIKO Linear Recirculating Bearing type LME are composed by a cylindrical outer ring, by a cage that retains the balls, by two end rings to retain the cage and/or, when required, contact seals. All of the components are designed and assembled to optimize the unit performance. The outer ring is suitably hardened to provide the longest possible life expectancy. The cage made of steel or engineered resin, depending upon the type of bearing selected, provide the retention and allow the proper recirculation of the balls.



2.1 Characteristics of linear bearings type LME

2.1.1 High rigidity

Linear bearings with steel outer ring offer high rigidity due to the large number of balls in contact. The units can be supplied with a steel cage and, when low weight is required, with resin cage.

2.1.2 Ease of assembly

The standard units can carry load in every direction. The large variety of housing units and shaft supports allow simple and easy mounting.

2.1.3 Ease of replacement

These units follow internationally recognized boundary and are therefore dimensionally interchangeable with competitive units. Replacement due to wear or damage is quick and simple.

2.1.4 Complete range

The **NIKO** range of products is quite broad. The characteristics can be summarized as follows:

- A) Closed type – standard version
- B) Adjustable type – These units have a longitudinal slot that allows the reduction of the operating clearance and the optimization of the unit rigidity.
- C) Open type – These units have an opening that corresponds to a single recirculating channel (50 to 100 deg). These units are used in conjunction with long shafts that are typically supported along the entire length to reduce the elastic deflection. When mounted in a suitable housing, the units allow the adjustment of the operating clearance.
- D) Flanged type – These units have a flange on the outer ring to allow the mounting without conventional housings.

2.2 Seals

Linear bearings LME can be supplied in the following versions:

- Without seals – LME
- With contact seals – LME..UU

The seals have the following functions:

- Prevent the ingress of contaminants
- Retain the lubricant in the bearing

In some applications, it may be necessary to use additional seals to prevent grease migration and thus prolong the maintenance interval.

3. Linear Recirculating Ball Bearing precision series type LME

3.1 Lubrication

Linear bearings type LME are supplied coated with rust inhibiting oil. Linear bearings type LME..UU are supplied packaged with lithium soap grease.

3.2 Mounting tolerances

The bearing assembly should be performed as to insure operation with adequate clearance. Unsuitable operating clearance could lead to poor running performance or lower than expected durability. The operating clearance of the adjustable or open version of the linear bearings can be adjusted by elastically deforming the outer ring. The suitable mounting tolerances for the mating components are shown in table 3.1 .

Note: The operating clearance is application dependent and could be zero or negative (preload). In the latter case the friction as well as the smooth running should be checked for suitability.

Table 3.1

Dimensional series	Shaft		Housing	
	Normal operating clearance	Operation without clearance	Normal operating clearance	Operation without clearance
LME	h6	j6	H7	J7

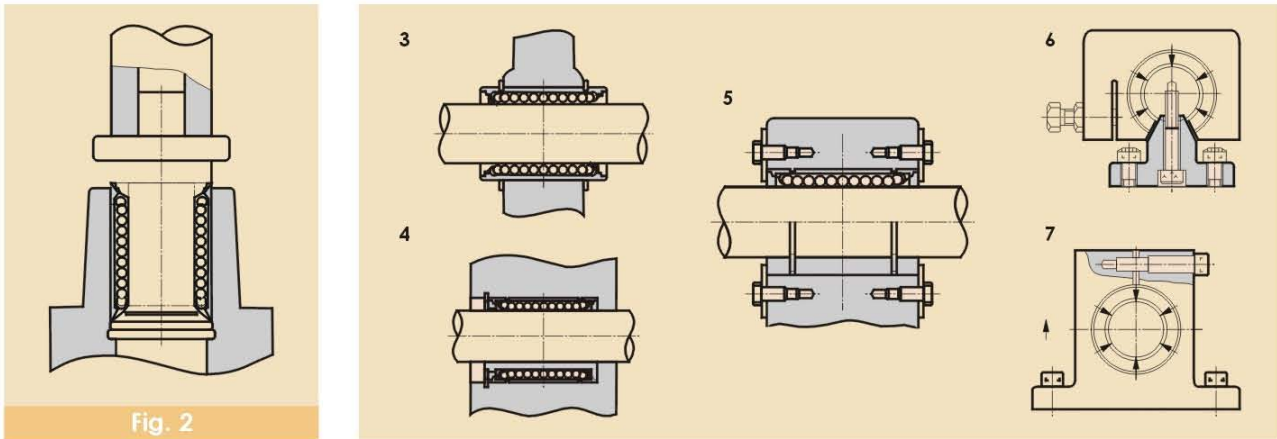

3.3 Installation

Some cleanliness precautions should be taken before assembling **NIKO** Linear Bearings in their housings. Lack of cleanliness could lead to reduction of the bearing life. The installation of the units is not particularly difficult, though precaution should be observed to avoid potential damages to the unit. Direct pressing onto the cage retaining rings should be avoided. A suitable tool should be used (Fig. 2) to provide pressure on the rim of the outer ring. Once the bearing is mounted in the housing, the assembled unit should be installed onto the shaft paying attention not to score the shaft or to pop the balls from the bearing. When two shafts assemblies are assembled in a parallel assembly, the parallelism between the shafts should be checked to insure smooth running. The mounting examples shown in Fig. 3 through 7 should be used as guidelines to design and select the suitable bearings and support units.

4. Load ratings

Dynamic load rating C

The dynamic load rating C is a load of constant magnitude under which 90% of a statistically significant number of apparently identical bearings would reach a theoretical life of 50 km without the apparent appearance of metal fatigue.

Static load rating Co

The static load rating Co is defined as the load that would cause a permanent deformation equal to 1/10,000 of the ball diameter at the most stressed contact point.

4.1 Life of a Linear Recirculating Ball Bearing

Repeated stresses onto the contact surfaces could lead to material fatigue. This will lead to the appearance of surface pitting. The life of the unit is defined as the duration before the appearance of pitting.

4.1.1 Rated life(L)

The rated life L is the total travelled distance which 90% of a statistically significant number of apparently identical bearings would reach under the same operating conditions without the apparent appearance of metal fatigue.

$$L = \left(\frac{C}{P}\right)^3 \cdot 50 \dots\dots\dots(1)$$

- L = rated life [km]
- C = dynamic load ratings [N]
- P = equivalent dynamic load [N]

When a system is subjected to a load equal to the dynamic load rating C the resulting life equal the rated life (50 km). The theoretical life of a linear bearing is affected by the load and by the operating conditions (temperature, vibration, shocks, load distribution, etc.). In such cases the theoretical life is calculated with the help of equation 2.

$$L = \left(\frac{f_H \cdot f_T \cdot f_C \cdot C}{F_w \cdot P}\right)^3 \cdot 50 \dots\dots\dots(2)$$

- L = Rated life [km]
- C = Dynamic load rating [N]
- P = Equivalent dynamic load [N]
- f_H = Hardness factor (see fig. 8)
- f_T = Temperature factor (see fig. 9)
- f_C = Contact coefficient (see table 4)
- f_w = Load factor (see table 5)

The following equation (3) allows the conversion of the rated life in hours.

$$L_h = \left(\frac{L \cdot 10}{2 \cdot l_s \cdot n_1 \cdot 60}\right)^3 \dots\dots\dots(3)$$

- L_h = rated life [hours]
- L_s = stroke length [m]
- L = rated life [km]
- n₁ = operating frequency [strokes/min]

• Hardness factor (f_H)

The load ratings for the linear bearing are calculated with the raceway hardness equal or higher than 58 HRC. When the raceway hardness is reduced, the load rating of the bearing is also reduced and must be corrected using the the accompanying chart (Fig.8).

• Temperature factor (f_T)

When a linear bearing operates at temperatures in excess of 100 deg. C, its hardness is affected and so is its ability to carry load. The load rating can be corrected by using the accompanying chart (Fig.9).

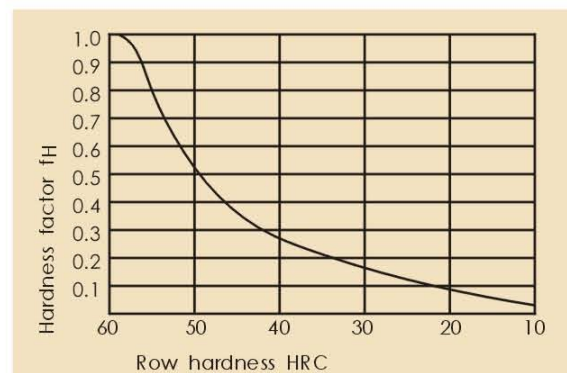

Fig. 8 Raceway hardness factor

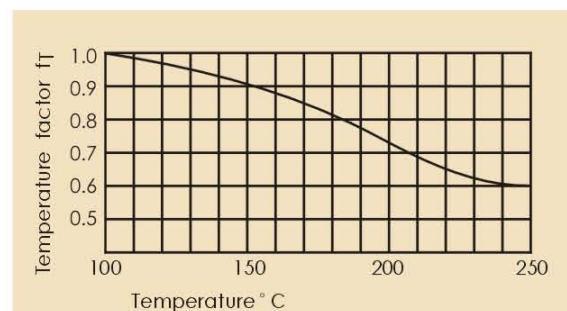

Fig. 9 Temperature factor

● Contact factor (fc)

Load biasing, attributed to mounting errors and multiple bearing assemblies can be accounted for by using the coefficient in table 4.1 .

Table 4.1 Contact factor

Number of bearings for shaft	Contact factor f _c
1	1,00
2	0,81
3	0,72
4	0,66
5	0,61

● Load factor (fw)

The loads acting on the linear units include payload, inertial effects during acceleration and deceleration as well as moment loads. All of these factors are difficult to assess and are further complicated by the potential presence of shocks and vibrations. A more practical solution involves the use of the coefficients in table 4.2 .

Table 4.2 Contact factor

Operating conditions	f _w
Low speed operations (<15 m/min) without shocks	1 - 1,5
Medium speed operation (60m/min) without shocks	1,5 - 2
High speed operations (>60m/min) with shocks	2 - 3,5

5. Static safety factor

For applications with a high requirement for accuracy and smooth running, the static safety factor fs should be higher than the values shown in table 5.1 to prevent permanent deformation at the contact points.

$$f_s = \frac{C_0}{P_0}$$

fs = static safety factor

Po = static equivalent load (N)

Co = static load rating (N)

Table 5.1 Static safety factor

Operating conditions	f _s
Shafts subjected to small deflections and low shocks	1 ÷ 2
Elastic deflection can cross load the units	2 ÷ 4
System subjected to shock & vibration	3 ÷ 5

6. Friction

Linear Recirculating Ball Bearings have a very low static coefficient of friction, virtually identical to the dynamic coefficient of friction. This results in low and uniform motion in any condition of load and speed without sick-slip.

$$F = \mu \cdot W + f \dots\dots\dots(4)$$

F = Friction force [N]

U = Friction coefficient [-]

f = Seal drag [N]

w = Load [N]

The magnitude of the friction force is affected by several factors. The type of bearing, the operating conditions, the type and quantity of the lubricant, the presence or lack of seals all impact the overall frictional behavior. Standard seals can add between 2 and 5 N to the overall friction force. The magnitude of the coefficient of friction depends upon the operating conditions such as load, moments and/or preload. Table 6.1 shows the dynamic coefficient of friction for each type of bearing under normal operating condition (P/C <= 0.2) and proper assembly.

Table 6.1 Friction coefficient

Type of bearing	Friction coefficient
KH	0.004 to 0.006
LME / LMB	0.002 to 0.003

7. Operating temperature

The operating temperature ranges of the various bearings are shown in table 7.1 Should the operating temperature exceed the limits shown in the table, please contact fait International Engineering. Stainless steel units, without seals, can operate between - 20/+ 120 degree. C

Table 7.1 Operating temperature

Bearing type	Operating temperature
KH	-20 to +120°C
LME / LMB	-20 to +110°C

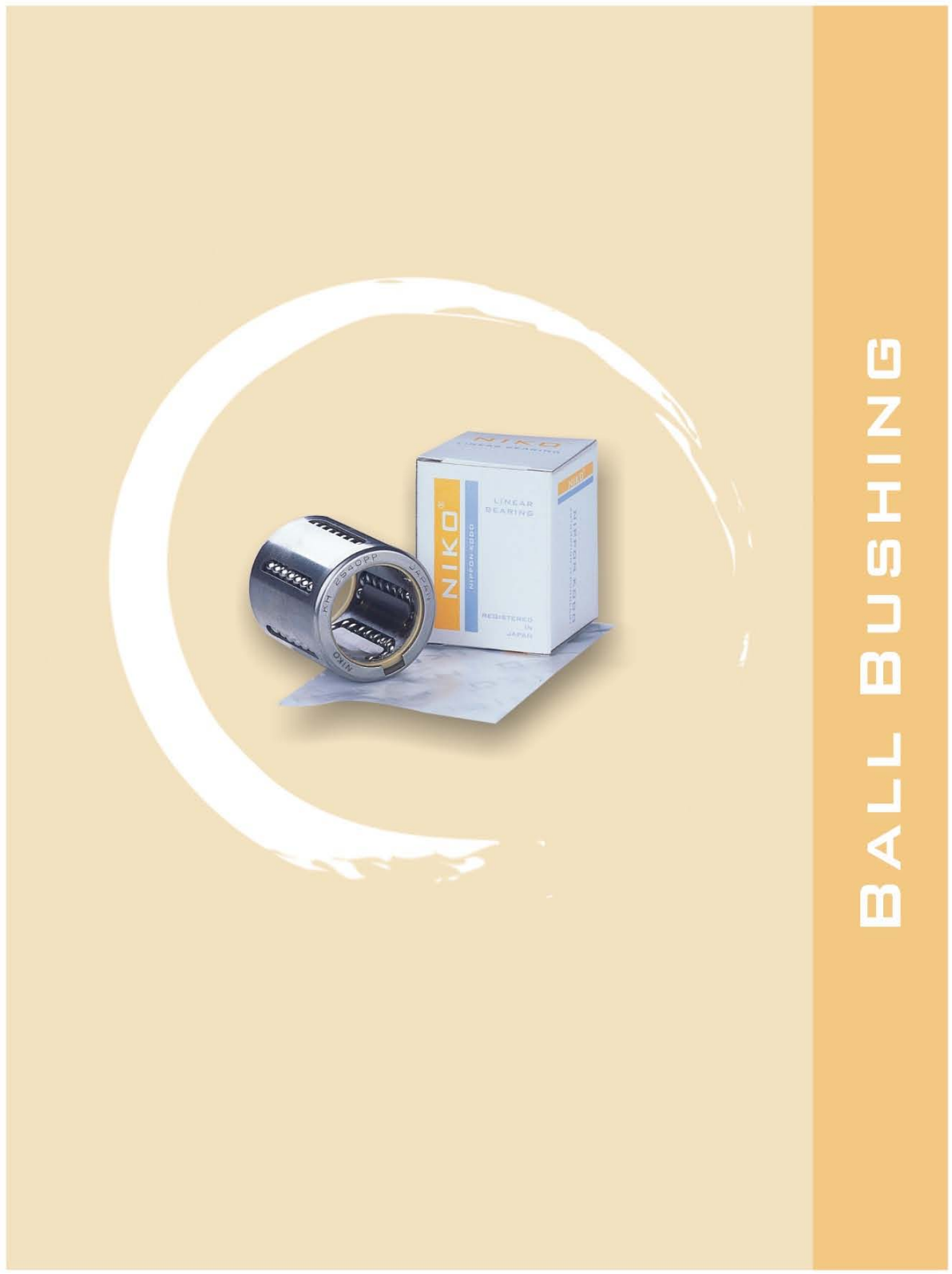

BALL BUSHING

LINEAR BALL BEARINGS
SERIES **LME..**

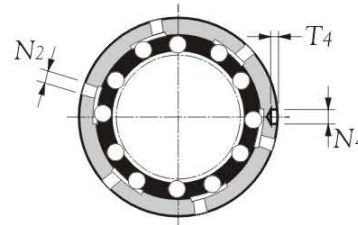
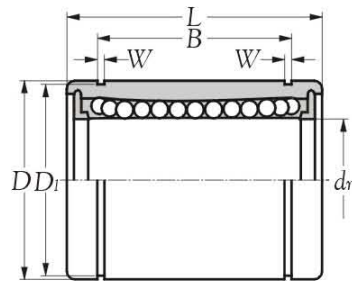

Boundary dimensions d mm	Bearing number				Number of ball tracks	Principal dimensions					
	standard steel retainer	standard resin retainer	with seals steel retainer	with seals resin retainer		d_r		D		L	
						mm	0.001mm	mm	0.001mm	mm	mm
5	-	LME 5	-	LME 5 UU AS	3	5	(+8/0)	12	(0/-8)	22	(0/-0.2)
8	LME 8 A AS	LME 8	LME 8 A UU AS	LME 8 UU AS	4	8	(+8/0)	16	(0/-8)	25	(0/-0.2)
10	LME 10 A AS	-	LME 10 A UU AS	-	4	10	(+8/0)	19	(0/-9)	29	(0/-0.2)
12	LME 12 A AS	LME 12	LME 12 A UU AS	LME 12 UU AS	4	12	(+8/0)	22	(0/-9)	32	(0/-0.2)
16	LME 16 A AS	LME 16	LME 16 A UU AS	LME 16 UU AS	5	16	(+9/-1)	26	(0/-9)	36	(0/-0.2)
20	LME 20 A AS	LME 20	LME 20 A UU AS	LME 20 UU AS	5	20	(+9/-1)	32	(0/-11)	45	(0/-0.2)
25	LME 25 A AS	LME 25	LME 25 A UU AS	LME 25 UU AS	6	25	(+11/-1)	40	(0/-11)	58	(0/-0.3)
30	LME 30 A AS	LME 30	LME 30 A UU AS	LME 30 UU AS	6	30	(+11/-1)	47	(0/-11)	68	(0/-0.3)
40	LME 40 A AS	LME 40	LME 40 A UU AS	LME 40 UU AS	6	40	(+13/-2)	62	(0/-13)	80	(0/-0.3)
50	LME 50 A AS	LME 50	LME 50 A UU AS	LME 50 UU AS	6	50	(+13/-2)	75	(0/-13)	100	(0/-0.3)
60	LME 60 A AS	LME 60	LME 60 A UU AS	LME 60 UU AS	6	60	(+13/-2)	90	(0/-15)	125	(0/-0.4)



Technical supplement

Cages	Precision	Grease
Steel - Nil		
Polymid - Nil	Normal (ISO)	Nil
Brass - Nil		

Remark: If you have more inquiry of technical, please inquire
NIKO web-site: [Http://www.nipponkodobearings.com](http://www.nipponkodobearings.com)

LINEAR BALL BEARINGS
SERIES LME..

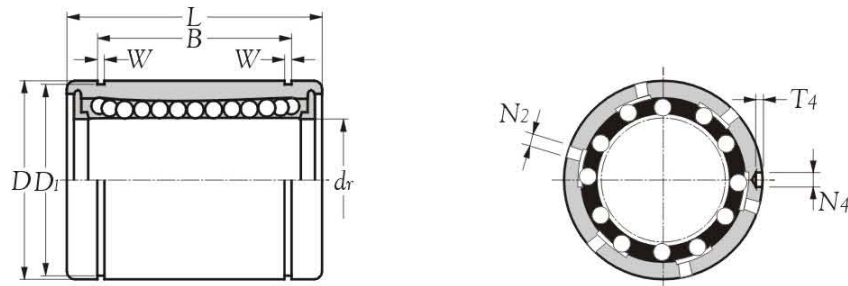

Principal dimensions			Roundness	Steel retainer maximum radial clearance	Resin retainer maximum radial clearance	Load ratings		Mass		
B	W	D ₁				dynamic C	static C ₀	steel retainer	resin retainer	
tolerance	mm	mm	0.001mm	0.001mm	0.001mm	N		kg(s).		
14.5	(0/-0.2)	1.10	11.5	12	-	-5	206	265	-	0.011
16.5	(0/-0.2)	1.10	15.2	12	-3	-5	265	402	0.022	0.020
22.0	(0/-0.2)	1.30	18.0	12	-4	-	372	549	0.036	-
22.9	(0/-0.2)	1.30	21.0	12	-4	-7	510	784	0.045	0.041
24.9	(0/-0.2)	1.30	24.9	12	-4	-7	578	892	0.060	0.065
31.5	(0/-0.2)	1.60	30.3	15	-6	-9	862	1370	0.102	0.091
44.1	(0/-0.3)	1.85	37.5	15	-6	-9	980	1570	0.235	0.215
52.1	(0/-0.3)	1.85	44.5	15	-8	-9	1570	2740	0.360	0.325
60.6	(0/-0.3)	2.15	59.0	17	-8	-13	2160	4020	0.770	0.705
77.6	(0/-0.3)	2.65	72.0	17	-13	-13	3820	7940	1.250	1.130
101.7	(0/-0.4)	3.15	86.5	20	-13	-16	4700	9800	2.220	2.220

LINEAR BALL BEARINGS
 SERIES **LME..AJ AS**

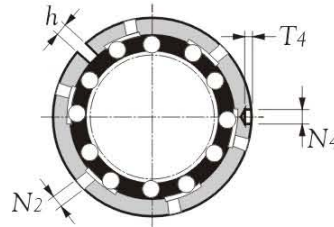
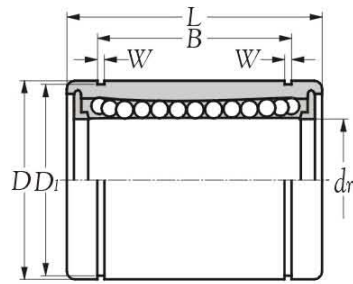

Boundary dimensions <i>d</i> mm	Bearing number				Number of ball tracks	Principal dimensions			
	standard steel retainer	standard resin retainer	with seals steel retainer	with seals resin retainer		<i>d_r</i> tolerance		<i>D</i> tolerance	
					mm	0.001mm	mm	0.001mm	
5	-	LME 5 AJ AS	-	LME 5 UUAJ AS	3	5	(+8/0)	12	(0/-8)
8	-	LME 8 AJ AS	-	LME 8 UUAJ AS	4	8	(+8/0)	16	(0/-8)
12	LME 12 A-AJ AS	LME 12 AJ AS	LME 12 A-UUAJ AS	LME 12 UUAJ AS	4	12	(+8/0)	22	(0/-9)
16	LME 16 A-AJ AS	LME 16 AJ AS	LME 16 A-UUAJ AS	LME 16 UUAJ AS	5	16	(+9/-1)	26	(0/-9)
20	LME 20 A-AJ AS	LME 20 AJ AS	LME 20 A-UUAJ AS	LME 20 UUAJ AS	5	20	(+9/-1)	32	(0/-11)
25	LME 25 A-AJ AS	LME 25 AJ AS	LME 25 A-UUAJ AS	LME 25 UUAJ AS	6	25	(+11/-1)	40	(0/-11)
30	LME 30 A-AJ AS	LME 30 AJ AS	LME 30 A-UUAJ AS	LME 30 UUAJ AS	6	30	(+11/-1)	47	(0/-11)
40	LME 40 A-AJ AS	LME 40 AJ AS	LME 40 A-UUAJ AS	LME 40 UUAJ AS	6	40	(+13/-2)	62	(0/-13)
50	LME 50 A-AJ AS	LME 50 AJ AS	LME 50 A-UUAJ AS	LME 50 UUAJ AS	6	50	(+13/-2)	75	(0/-13)
60	LME 60 A-AJ AS	LME 60 AJ AS	LME 60 A-UUAJ AS	LME 60 UUAJ AS	6	60	(+13/-2)	90	(0/-15)

Technical supplement

Cages	Precision	Grease
Steel - Nil		
Polymid - Nil	Normal (ISO)	Nil
Brass - Nil		

Remark: If you have more inquiry of technical, please inquire
 NIKO web-site: <http://www.nipponkodobearings.com>

LINEAR BALL BEARINGS
SERIES LME..AJ AS

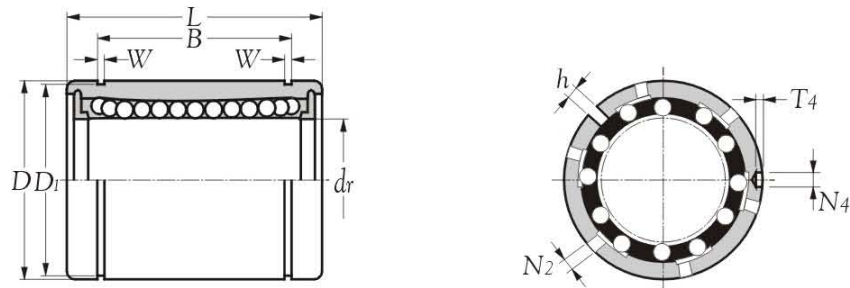

L	Principal dimensions					Roundness	Steel retainer maximum radial clearance	Resin retainer maximum radial clearance	Load ratings		Mass		
	tolerance	B	W	D ₁	h				dynamic C	static C ₀	steel retainer	resin retainer	
mm	mm	mm	mm	mm	mm	0.001mm	0.001mm	0.001mm	N		kg(s).		
22	(0/-0.2)	14.5	(0/-0.2)	1.10	11.5	1.0	12	-	-5	206	265	0.011	-
25	(0/-0.2)	16.5	(0/-0.2)	1.10	15.2	1.0	12	-3	-5	265	402	0.020	0.022
32	(0/-0.2)	22.9	(0/-0.2)	1.30	21.0	1.5	12	-4	-7	510	784	0.041	0.045
36	(0/-0.2)	24.9	(0/-0.2)	1.30	24.9	1.5	12	-4	-7	578	892	0.065	0.060
45	(0/-0.2)	31.5	(0/-0.2)	1.60	30.3	2.0	15	-6	-9	862	1370	0.091	0.102
58	(0/-0.3)	44.1	(0/-0.3)	1.85	37.5	2.0	15	-6	-9	980	1570	0.215	0.235
68	(0/-0.3)	52.1	(0/-0.3)	1.85	44.5	2.0	15	-8	-9	1570	2740	0.325	0.360
80	(0/-0.3)	60.6	(0/-0.3)	2.15	59.0	3.0	17	-8	-13	2160	4020	0.705	0.770
100	(0/-0.3)	77.6	(0/-0.3)	2.65	72.0	3.0	17	-13	-13	3820	7940	1.130	1.250
125	(0/-0.4)	101.7	(0/-0.4)	3.15	86.5	3.0	20	-13	-16	4700	9800	2.220	2.220

LINEAR BALL BEARINGS
SERIES **LME..OP**

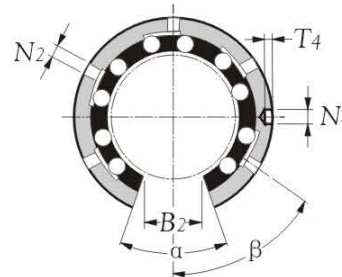
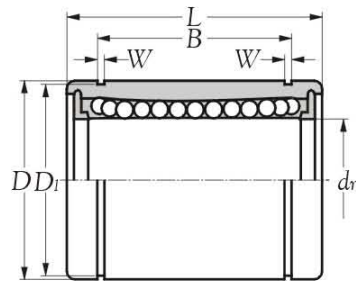

Boundary dimensions <i>d</i> mm	Bearing number				Number of ball tracks	Principal dimensions			
	standard steel retainer	standard resin retainer	with seals steel retainer	with seals resin retainer		<i>d_r</i> tolerance		<i>D</i> tolerance	
					mm	0.001mm	mm	0.001mm	
12	LME 12 A OP	LME 12 OP AS	LME 12 A UUOP AS	LME 12 UUOP AS	3	12	(+8/0)	22	(0/-9)
16	LME 16 A OP	LME 16 OP AS	LME 16 A UUOP AS	LME 16 UUOP AS	4	16	(+9/-1)	26	(0/-9)
20	LME 20 A OP	LME 20 OP AS	LME 20 A UUOP AS	LME 20 UUOP AS	4	20	(+9/-1)	32	(0/-11)
25	LME 25 A OP	LME 25 OP AS	LME 25 A UUOP AS	LME 25 UUOP AS	5	25	(+11/-1)	40	(0/-11)
30	LME 30 A OP	LME 30 OP AS	LME 30 A UUOP AS	LME 30 UUOP AS	5	30	(+11/-1)	47	(0/-11)
40	LME 40 A OP	LME 40 OP AS	LME 40 A UUOP AS	LME 40 UUOP AS	5	40	(+13/-2)	62	(0/-13)
50	LME 50 A OP	LME 50 OP AS	LME 50 A UUOP AS	LME 50 UUOP AS	5	50	(+13/-2)	75	(0/-13)
60	LME 60 A OP	LME 60 OP AS	LME 60 A UUOP AS	LME 60 UUOP AS	5	60	(+13/-2)	90	(0/-15)



Technical supplement

	Cages	Precision	Grease
Steel -	Nil		
Polymid -	Nil	Normal (ISO)	Nil
Brass -	Nil		

Remark: If you have more inquiry of technical, please inquire
NIKO web-site: [Http://www.nipponkodobearings.com](http://www.nipponkodobearings.com)

LINEAR BALL BEARINGS
SERIES LME..OP

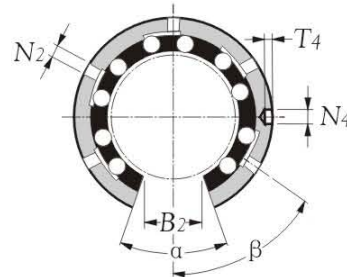
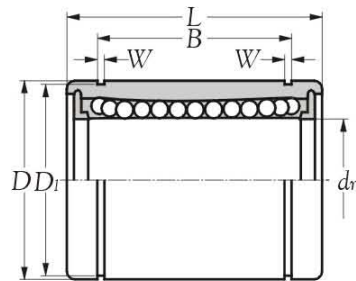

L	Principal dimensions						Roundness	Steel retainer maximum radial clearance	Resin retainer maximum radial clearance	Load ratings		Mass		
	tolerance	B	W	D_1	h_1	θ				dynamic C	static C_0	steel retainer	resin retainer	
mm	mm	mm	mm	mm			0.001mm	0.001mm	0.001mm	N		kg(s).		
32	(0/-0.2)	22.9	(0/-0.2)	1.30	21.0	7.5	78°	12	-4	-7	510	784	0.045	0.041
36	(0/-0.2)	24.9	(0/-0.2)	1.30	24.9	10.0	78°	12	-4	-7	578	892	0.060	0.065
45	(0/-0.2)	31.5	(0/-0.2)	1.60	30.3	10.0	60°	15	-6	-9	862	1370	0.102	0.091
58	(0/-0.3)	44.1	(0/-0.3)	1.85	37.5	12.5	60°	15	-6	-9	980	1570	0.235	0.215
68	(0/-0.3)	52.1	(0/-0.3)	1.85	44.5	12.5	50°	15	-8	-9	1570	2740	0.360	0.325
80	(0/-0.3)	60.6	(0/-0.3)	2.15	59.0	16.8	50°	17	-8	-13	2160	4020	0.770	0.705
100	(0/-0.4)	77.6	(0/-0.4)	2.65	72.0	21.0	50°	17	-13	-13	3820	7940	1.250	1.130
125	(0/-0.4)	101.7	(0/-0.4)	3.15	86.5	27.2	54°	20	-13	-16	4700	9800	2.220	2.220

LINEAR BALL BEARINGS
SERIES **LME..F**

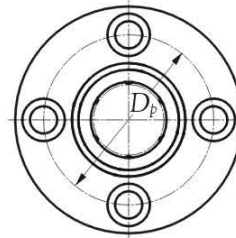
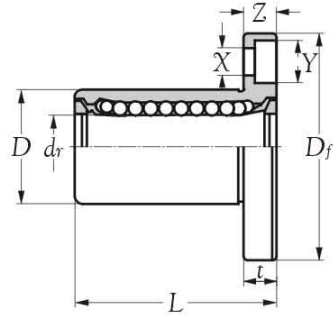

Boundary dimensions <i>d</i> mm	Bearing number		Number of ball tracks	Principal dimensions					
	standard resin retainer	with seals resin retainer		<i>d_r</i>		<i>D</i>		<i>L</i>	
				tolerance mm	0.001mm	tolerance mm	0.001mm	tolerance mm	mm
8	LMEF 8	LMEF 8 UU	4	8	(+8/0)	16	(0/-13)	25	(±0.3)
12	LMEF 12	LMEF 12 UU	4	12	(+8/0)	22	(0/-16)	32	(±0.3)
16	LMEF 16	LMEF 16 UU	5	16	(+9/-1)	26	(0/-16)	36	(±0.3)
20	LMEF 20	LMEF 20 UU	5	20	(+9/-1)	32	(0/-19)	45	(±0.3)
25	LMEF 25	LMEF 25 UU	6	25	(+11/-1)	40	(0/-19)	58	(±0.3)
30	LMEF 30	LMEF 30 UU	6	30	(+11/-1)	47	(0/-19)	68	(±0.3)
40	LMEF 40	LMEF 40 UU	6	40	(+13/-2)	62	(0/-22)	80	(±0.3)
50	LMEF 50	LMEF 50 UU	6	50	(+13/-2)	75	(0/-22)	100	(±0.3)
60	LMEF 60	LMEF 60 UU	6	60	(+13/-2)	90	(0/-25)	125	(±0.3)



Technical supplement

Cages	Precision	Grease
Steel - Nil	Normal (ISO)	Nil
Polymid - Nil		
Brass - Nil		

Remark: If you have more inquiry of technical, please inquire
NIKO web-site: [Http://www.nipponkodobearings.com](http://www.nipponkodobearings.com)

LINEAR BALL BEARINGS
SERIES LME..F

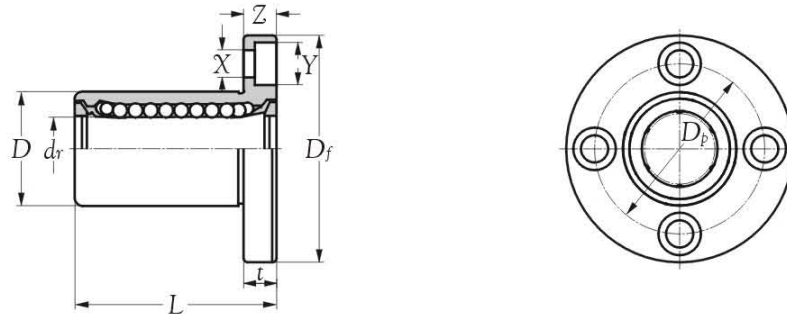

D_f	Principa dimensions flange			Roundness 0.001mm	Squareness 0.001mm	Load ratings		Mass kg(s). (approx.)
	t	D_p	$X \times Y \times Z$			dynamic C	static C_o	
mm								
32	5	24	3.5 x 6.0 x 3.1	12	12	265	402	0.041
42	6	32	4.5 x 7.5 x 4.1	12	12	510	784	0.080
46	6	36	4.5 x 7.5 x 4.1	12	12	578	892	0.103
54	8	43	5.5 x 9.0 x 5.1	15	15	862	1370	0.182
62	8	51	5.5 x 9.0 x 5.1	15	15	980	1570	0.335
76	10	62	6.6 x 11 x 6.1	15	15	1570	2740	0.560
98	13	80	9.0 x 14 x 8.1	17	17	2160	4020	1.175
112	13	94	9.0 x 14 x 8.1	17	17	3820	7940	1.745
134	18	112	11 x 17 x 11.1	20	20	4700	9800	3.220

LINEAR BALL BEARINGS
SERIES **LME..K**

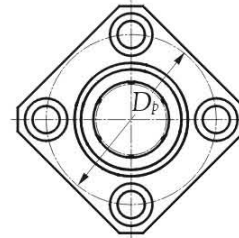
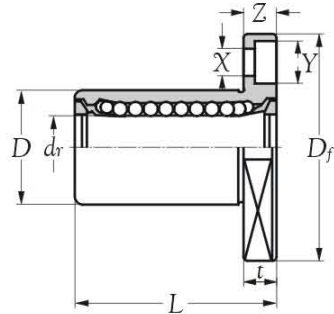

Boundary dimensions mm	Bearing number		Number of ball tracks	Principal dimensions					
	standard resin retainer	with seals resin retainer		d_r		D		L	
				mm	0.001mm	mm	0.001mm	mm	mm
8	LMEK 8	LMEK 8 UU	4	8	(+8/0)	16	(0/-13)	25	(±0.3)
12	LMEK 12	LMEK 12 UU	4	12	(+8/0)	22	(0/-16)	32	(±0.3)
16	LMEK 16	LMEK 16 UU	5	16	(+9/-1)	26	(0/-16)	36	(±0.3)
20	LMEK 20	LMEK 20 UU	5	20	(+9/-1)	32	(0/-19)	45	(±0.3)
25	LMEK 25	LMEK 25 UU	6	25	(+11/-1)	40	(0/-19)	58	(±0.3)
30	LMEK 30	LMEK 30 UU	6	30	(+11/-1)	47	(0/-19)	68	(±0.3)
40	LMEK 40	LMEK 40 UU	6	40	(+13/-2)	62	(0/-22)	80	(±0.3)
50	LMEK 50	LMEK 50 UU	6	50	(+13/-2)	75	(0/-22)	100	(±0.3)
60	LMEK 60	LMEK 60 UU	6	60	(+13/-2)	90	(0/-25)	125	(±0.3)



Technical supplement

Cages	Precision	Grease
Steel - Nil		
Polymid - Nil	Normal (ISO)	Nil
Brass - Nil		

Remark: If you have more inquiry of technical, please inquire
NIKO web-site: [Http://www.nipponkodobearings.com](http://www.nipponkodobearings.com)

LINEAR BALL BEARINGS
SERIES LME..K

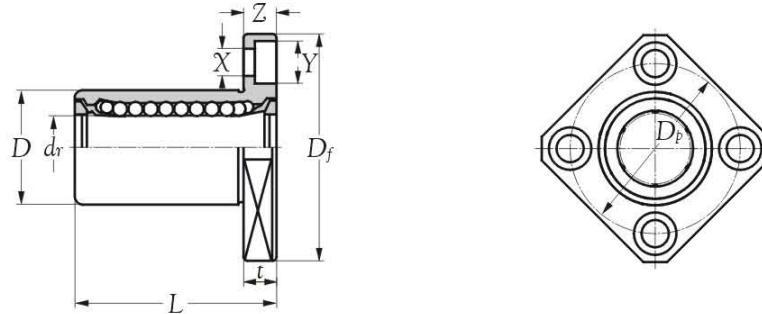

D_f	Principa dimensions flange			Roundness 0.001mm	Squareness 0.001mm	Load ratings		Mass kg(s). (approx.)
	t	D_p	$X \times Y \times Z$			dynamic C	static C_o	
mm								
32	5	24	3.5 x 6.0 x 3.1	12	12	265	402	0.041
42	6	32	4.5 x 7.5 x 4.1	12	12	510	784	0.080
46	6	36	4.5 x 7.5 x 4.1	12	12	578	892	0.103
54	8	43	5.5 x 9.0 x 5.1	15	15	862	1370	0.182
62	8	51	5.5 x 9.0 x 5.1	15	15	980	1570	0.335
76	10	62	6.6 x 11 x 6.1	15	15	1570	2740	0.560
98	13	80	9.0 x 14 x 8.1	17	17	2160	4020	1.175
112	13	94	9.0 x 14 x 8.1	17	17	3820	7940	1.745
134	18	112	11.0 x 17 x 11.1	20	20	4700	9800	3.220

SUPER BALL BUSHINGS
SERIES LMES

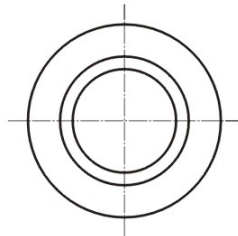

LMES..close, UU

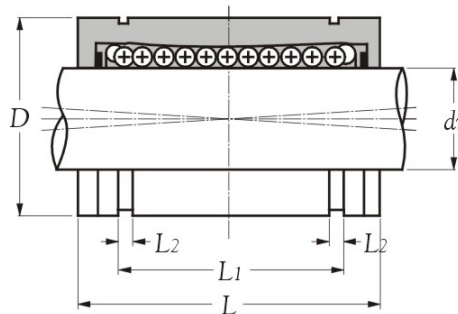

Boundary dimensions <i>d</i> mm	Bearing number		Number of ball tracks	Principal dimensions						Load ratings		Mass kg. (approx.)
				<i>d_r</i> tolerance mm 0.001mm	<i>D</i> ±0.1	<i>L</i> ±0.2	<i>L₁</i> ±0.2	<i>L₂</i> min.	dynamic <i>C</i>	static <i>C₀</i>		
10	LMES 10	LMES 10 UU	5	10	+8 ~ 0	19	29	21.7	1.35	750	550	0.017
12	LMES 12	LMES 12 UU	5	12	+8 ~ 0	22	32	22.7	1.35	1230	1100	0.023
16	LMES 16	LMES 16 UU	5	16	+9 ~ 1	26	36	24.7	1.35	1550	1250	0.028
20	LMES 20	LMES 20 UU	6	20	+9 ~ 1	32	45	31.3	1.65	2580	1670	0.061
25	LMES 25	LMES 25 UU	6	25	+11 ~ 1	40	58	43.8	1.90	3800	2750	0.122
30	LMES 30	LMES 30 UU	6	30	+11 ~ 1	47	68	51.8	1.90	4710	2800	0.185
40	LMES 40	LMES 40 UU	6	40	+13 ~ 2	62	80	60.4	2.20	6500	5720	0.360
50	LMES 50	LMES 50 UU	6	50	+13 ~ 2	75	100	77.4	2.70	11460	7940	0.580



Technical supplement

Gages	Precision	Grease
Steel - Nil		
Polymid - Nil	Normal (ISO)	Nil
Brass - Nil		

Remark: If you have more inquiry of technical, please inquire
NIKO web-site: [Http://www.nipponkodobearings.com](http://www.nipponkodobearings.com)

SUPER BALL BUSHINGS
SERIES LMES..OP

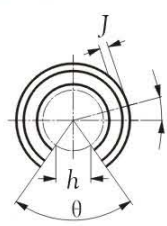

LMES 12 OP

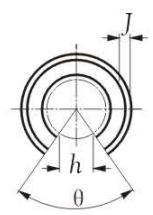
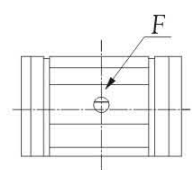

LMES 16 OP, LMES 20 OP

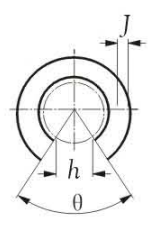

LMES 25 OP

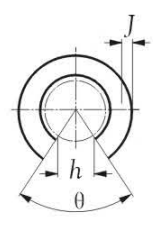
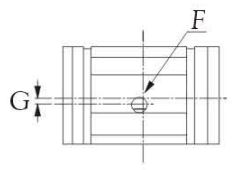

LMES 30 OP, LMES 40 OP, LMES 50 OP

Boundary dimensions <i>d</i> mm	Bearing number		Number of ball tracks	Principal dimensions								Load ratings		Mass kg. (approx.)
	<i>D</i> ±0.1	<i>L</i> ±0.2		<i>L</i> ₂	<i>h</i>	θ°	<i>F</i>	<i>G</i>	<i>J</i>	dynamic <i>C</i>	static <i>C</i> ₀			
12	LMES 12OP	LMES 12UUOP	4	22	32	1.35	6.5	66	3.0	-	0.7	1290	1260	0.018
16	LMES 16OP	LMES 16UUOP	4	26	36	1.35	9.0	68	3.0	-	0.7	1640	1320	0.022
20	LMES 20OP	LMES 20UUOP	5	32	45	1.65	9.0	55	3.0	-	0.9	2630	1720	0.051
25	LMES 25OP	LMES 25UUOP	5	40	58	1.90	11.5	57	3.0	1.5	1.4	3910	2850	0.102
30	LMES 30OP	LMES 30UUOP	5	47	68	1.90	14.0	57	3.0	2.0	2.2	4850	2900	0.155
40	LMES 40OP	LMES 40UUOP	5	62	80	2.20	19.5	56	3.0	1.5	2.7	6700	5900	0.300
50	LMES 50OP	LMES 50UUOP	5	75	100	2.70	22.5	54	3.0	2.5	2.3	11700	8100	0.480

Technical supplement

	Cages	Precision	Grease
Steel -	Nil		
Polymid -	Nil	Normal (ISO)	
Brass -	Nil		Nil

Remark: If you have more inquiry of technical, please inquire
 NIKO web-site: [Http://www.nipponkodobearings.com](http://www.nipponkodobearings.com)

LINEAR BALL BEARINGS
SERIES KH

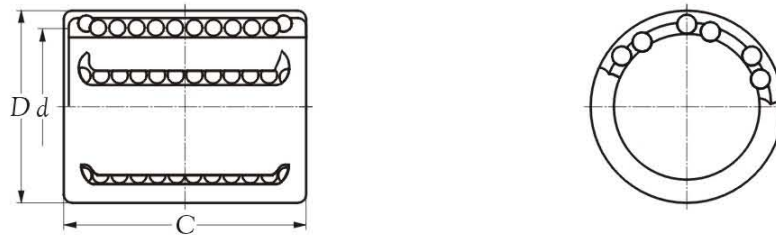

Boundary dimensions <i>d</i> mm	Bearing number	Number of ball tracks	Principal dimensions		Basic load ratings		Max runout speed		Mass kg. (approx.)
			<i>D</i> mm	<i>C</i> mm	dynamic <i>C</i> N	static <i>C₀</i> N	grease oil	r/min	
6	KH 0622	4	12	22	400	239	41	24	0.0070
6	KH 0622 PP	4	12	22	400	239	41	24	0.0070
8	KH 0824	4	15	24	435	280	44	29	0.0120
8	KH 0824 PP	4	15	24	435	280	44	29	0.0120
10	KH 1026	4	17	26	500	370	51	38	0.0145
10	KH 1026 PP	4	17	26	500	370	51	38	0.0145
12	KH 1228	5	19	28	620	510	63	52	0.0185
12	KH 1228 PP	5	19	28	620	510	63	52	0.0185
14	KH 1428	5	21	28	620	520	63	53	0.0205
14	KH 1428 PP	5	21	28	620	520	63	53	0.0205
16	KH 1630	5	24	30	800	620	82	63	0.0275
16	KH 1630 PP	5	24	30	800	620	82	63	0.0275
20	KH 2030	6	28	30	950	790	97	81	0.0325
20	KH 2030 PP	6	28	30	950	790	97	81	0.0325
25	KH 2540	6	35	40	1990	1670	203	170	0.0660
25	KH 2540 PP	6	35	40	1990	1670	203	170	0.0660
30	KH 3050	7	40	50	2800	2700	285	275	0.0950
30	KH 3050 PP	7	40	50	2800	2700	285	275	0.0950
40	KH 4060	8	52	60	4400	4450	449	454	0.1820
40	KH 4060 PP	8	52	60	4400	4450	449	454	0.1820
50	KH 5070	9	62	70	5500	6300	561	642	0.2520
50	KH 5070 PP	9	62	70	5500	6300	561	642	0.2520

Technical supplement

Cages	Precision	Grease
Steel - Nil		
Polymid - Nil	Normal (ISO)	Nil
Brass - Nil		

Remark: If you have more inquiry of technical, please inquire
NIKO web-site: [Http://www.nipponkodobearings.com](http://www.nipponkodobearings.com)



**ALUMINIUM HOUSINGS
& COMPLETE UNITS**

ALUMINIUM HOUSINGS
SERIES **FGWA**

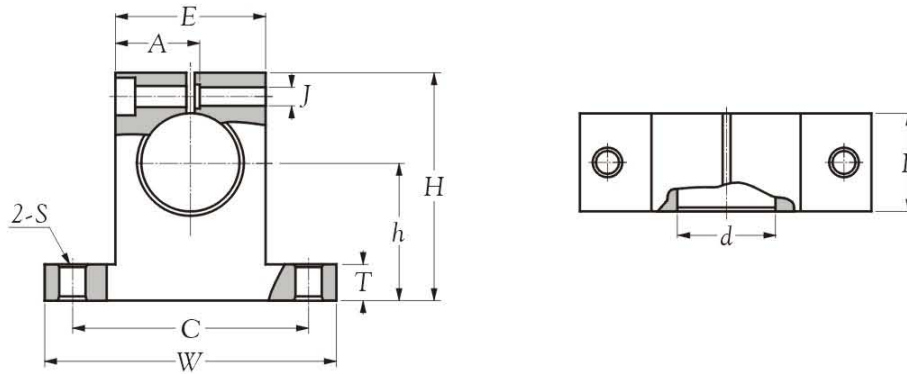

Boundary dimensions <i>d</i> mm	Bearing number	Principal dimensions											Mass kg. (approx.)
		<i>d</i>	<i>W</i>	<i>C</i>	<i>H</i>	<i>L</i>	<i>h</i>	<i>T</i>	<i>E</i>	<i>A</i>	<i>J</i>	<i>S</i>	
		tolerance mm 0.001mm	tolerance mm 0.001mm	tolerance mm 0.001mm	tolerance mm 0.001mm	tolerance mm 0.001mm	tolerance mm 0.001mm	tolerance mm 0.001mm	mm				
12	FGWA 12	12 ^{+0.018} / ₀	42 32	±0.15	35 ±0.30	12 ±0.20	20 ±0.020	5.5	20	12.0	M3	5.5	0.024
16	FGWA 16	16 ^{+0.018} / ₀	50 40	±0.15	42 ±0.30	16 ±0.20	25 ±0.020	6.5	28	16.0	M3	5.5	0.050
20	FGWA 20	20 ^{+0.021} / ₀	60 45	±0.15	50 ±0.30	20 ±0.20	30 ±0.020	8.0	32	18.0	M4	5.5	0.080
25	FGWA 25	25 ^{+0.021} / ₀	74 60	±0.15	58 ±0.30	25 ±0.20	35 ±0.020	9.0	38	21.0	M5	6.6	0.132
30	FGWA 30	30 ^{+0.021} / ₀	84 68	±0.15	68 ±0.30	28 ±0.20	40 ±0.020	10.0	45	24.5	M6	9.0	0.200
40	FGWA 40	40 ^{+0.025} / ₀	108 86	±0.15	86 ±0.30	32 ±0.20	50 ±0.020	12.0	56	31.0	M8	11.0	0.350



Technical supplement

Cages	Precision	Grease
Steel - Nil		
Polymid - Nil	Normal (ISO)	Nil
Brass - Nil		

Remark: If you have more inquiry of technical, please inquire
NIKO web-site: [Http://www.nipponkodobearings.com](http://www.nipponkodobearings.com)

ALUMINIUM HOUSINGS
SERIES **SB..AS**

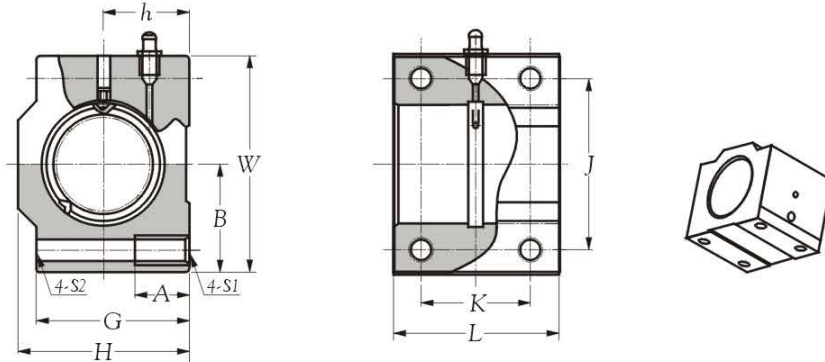

Bearing number	Principal dimensions										Mass kg(s). (approx.)	
	<i>h</i>	<i>B</i>	<i>W</i>	<i>H</i>	<i>G</i>	<i>A</i>	<i>J</i>	<i>S1</i>	<i>S2</i>	<i>K</i>		<i>L</i>
	tolerance mm 0.001mm	tolerance mm 0.001mm	tolerance mm 0.001mm	tolerance mm 0.001mm	tolerance mm 0.001mm	tolerance mm 0.001mm	tolerance mm 0.001mm			tolerance mm 0.001mm		tolerance mm 0.001mm
SB 16 AS	22 ±0.02	26.5 ±0.02	53 0 ~ -0.3	42 0 ~ -0.3	37.0	13	40 ±0.15	M6	5.3	26 ±0.15	36 0 ~ -0.2	0.202
SB 20 AS	25 ±0.02	30.0 ±0.02	60 0 ~ -0.3	50 0 ~ -0.3	44.0	18	45 ±0.15	M8	6.6	32 ±0.15	45 0 ~ -0.2	0.301
SB 25 AS	35 ±0.02	39.0 ±0.02	78 0 ~ -0.3	60 0 ~ -0.3	52.5	26	60 ±0.15	M10	8.4	40 ±0.15	58 0 ~ -0.2	0.659
SB 30 AS	35 ±0.02	43.5 ±0.02	87 0 ~ -0.3	70 0 ~ -0.3	62.5	26	68 ±0.15	M10	8.4	45 ±0.15	68 0 ~ -0.2	1.000
SB 40 AS	45 ±0.02	54.0 ±0.01	108 0 ~ -0.3	90 0 ~ -0.3	80.0	26	86 ±0.15	M12	10.5	58 ±0.15	80 0 ~ -0.2	2.233

SERIES **SB LME..**

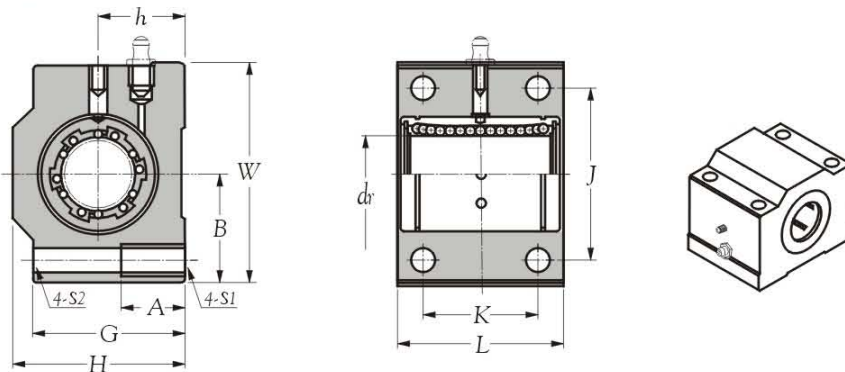

Bearing number	Principal dimensions										Mass kg(s). (approx.)	
	<i>h</i>	<i>B</i>	<i>W</i>	<i>H</i>	<i>G</i>	<i>A</i>	<i>J</i>	<i>S1</i>	<i>S2</i>	<i>K</i>		<i>L</i>
	tolerance mm 0.001mm	tolerance mm 0.001mm	tolerance mm 0.001mm	tolerance mm 0.001mm	tolerance mm 0.001mm	tolerance mm 0.001mm	tolerance mm 0.001mm			tolerance mm 0.001mm		tolerance mm 0.001mm
SB LME 16 UUAS	22 ±0.02	26.5 ±0.02	53 0 ~ -0.3	42 0 ~ -0.3	37.0	13	40 ±0.15	M6	5.3	26 ±0.15	36 0 ~ -0.2	0.202
SB LME 20 UUAS	25 ±0.02	30.0 ±0.02	60 0 ~ -0.3	50 0 ~ -0.3	44.0	18	45 ±0.15	M8	6.6	32 ±0.15	45 0 ~ -0.2	0.301
SB LME 25 UUAS	35 ±0.02	39.0 ±0.02	78 0 ~ -0.3	60 0 ~ -0.3	52.5	26	60 ±0.15	M10	8.4	40 ±0.15	58 0 ~ -0.2	0.659
SB LME 30 UUAS	35 ±0.02	43.5 ±0.02	87 0 ~ -0.3	70 0 ~ -0.3	62.5	26	68 ±0.15	M10	8.4	45 ±0.15	68 0 ~ -0.2	1.000
SB LME 40 UUAS	45 ±0.02	54.0 ±0.01	108 0 ~ -0.3	90 0 ~ -0.3	80.0	26	86 ±0.15	M12	10.5	58 ±0.15	80 0 ~ -0.2	2.233

Technical supplement

	Cages	Precision	Grease
	Steel - Nil		
	Polymid - Nil	Normal (ISO)	
	Brass - Nil		Nil

Remark: If you have more inquiry of technical, please inquire
NIKO web-site: [Http://www.nipponkodobearings.com](http://www.nipponkodobearings.com)

ALUMINIUM HOUSINGS
SERIES **SO..AS**

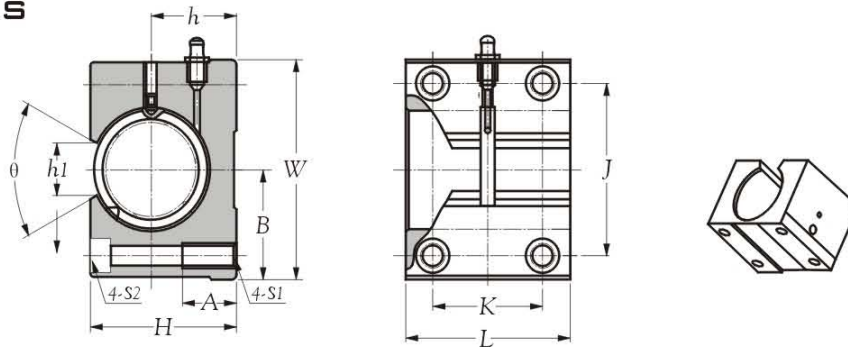

Bearing number	Principal dimensions												Mass kg(s). (approx.)
	<i>h</i>	<i>B</i>	<i>W</i>	<i>H</i>	<i>A</i>	<i>J</i>	<i>S1</i>	<i>S2</i>	<i>K</i>	<i>L</i>	<i>h1</i>	θ	
	tolerance mm 0.001mm	tolerance mm 0.001mm	tolerance mm 0.001mm	tolerance mm 0.001mm	tolerance mm 0.001mm	tolerance mm 0.001mm	tolerance mm 0.001mm	tolerance mm 0.001mm	tolerance mm 0.001mm	tolerance mm 0.001mm	tolerance mm 0.001mm	tolerance mm 0.001mm	
SO 16 AS	22 ±0.02	26.5±0.02	53 0~-0.3	35 0~-0.3	13	40 ±0.15	M6	5.3	26 ±0.15	36 0~-0.2	16.4 ±0.3	78°	0.159
SO 20 AS	25 ±0.02	30.0±0.02	60 0~-0.3	42 0~-0.3	18	45 ±0.15	M8	6.5	32 ±0.15	45 0~-0.2	16.0 ±0.3	60°	0.259
SO 25 AS	35 ±0.02	39.0±0.02	78 0~-0.3	51 0~-0.3	22	60 ±0.15	M10	8.5	40 ±0.15	58 0~-0.2	20.0 ±0.3	60°	0.574
SO 30 AS	35 ±0.02	43.5±0.02	87 0~-0.3	60 0~-0.3	22	68 ±0.15	M10	8.5	45 ±0.15	68 0~-0.2	19.9 ±0.3	50°	1.453
SO 40 AS	45 ±0.02	54.0±0.01	108 0~-0.3	77 0~-0.3	26	86 ±0.15	M12	10.5	58 ±0.15	80 0~-0.2	26.1 ±0.3	50°	1.996

SERIES **SO LME..**

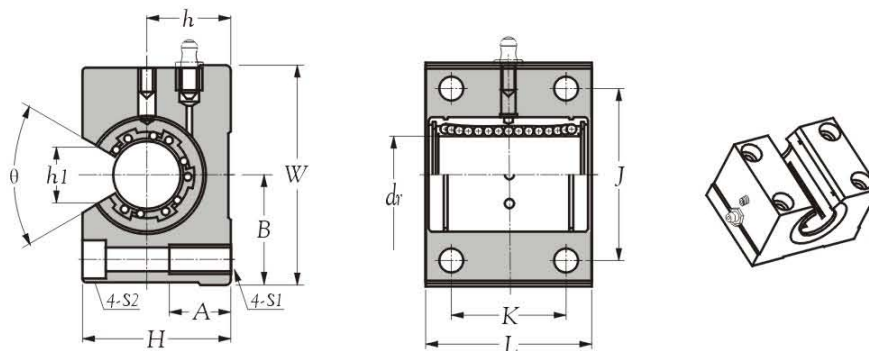

Bearing number	Principal dimensions												Mass kg(s). (approx.)
	<i>h</i>	<i>B</i>	<i>W</i>	<i>H</i>	<i>A</i>	<i>J</i>	<i>S1</i>	<i>S2</i>	<i>K</i>	<i>L</i>	<i>h1</i>	θ	
	tolerance mm 0.001mm	tolerance mm 0.001mm	tolerance mm 0.001mm	tolerance mm 0.001mm	tolerance mm 0.001mm	tolerance mm 0.001mm	tolerance mm 0.001mm	tolerance mm 0.001mm	tolerance mm 0.001mm	tolerance mm 0.001mm	tolerance mm 0.001mm	tolerance mm 0.001mm	
SO LME 16 UUOP AS	22 ±0.02	26.5±0.02	53 0~-0.3	35 0~-0.3	13	40 ±0.15	M6	5.3	26 ±0.15	36 0~-0.2	16.4 ±0.3	78°	0.159
SO LME 20 UUOP AS	25 ±0.02	30.0±0.02	60 0~-0.3	42 0~-0.3	18	45 ±0.15	M8	6.5	32 ±0.15	45 0~-0.2	16.0 ±0.3	60°	0.259
SO LME 25 UUOP AS	35 ±0.02	39.0±0.02	78 0~-0.3	51 0~-0.3	22	60 ±0.15	M10	8.5	40 ±0.15	58 0~-0.2	20.0 ±0.3	60°	0.574
SO LME 30 UUOP AS	35 ±0.02	43.5±0.02	87 0~-0.3	60 0~-0.3	22	68 ±0.15	M10	8.5	45 ±0.15	68 0~-0.2	19.9 ±0.3	50°	1.453
SO LME 40 UUOP AS	45 ±0.02	54.0±0.01	108 0~-0.3	77 0~-0.3	26	86 ±0.15	M12	10.5	58 ±0.15	80 0~-0.2	26.1 ±0.3	50°	1.996

Technical supplement

Cages	Precision	Grease
Steel - Nil		
Polymid - Nil	Normal (ISO)	
Brass - Nil		Nil

Remark: If you have more inquiry of technical, please inquire
NIKO web-site: [Http://www.nipponkodobearings.com](http://www.nipponkodobearings.com)

ALUMINIUM HOUSINGS
SERIES S2B..N

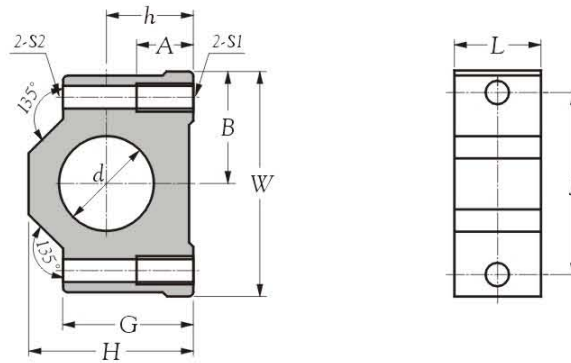

Boundary dimensions d mm	Bearing number	Principal dimensions										Mass kg. (approx.)		
		h		B		W	H	A	J		S1		S2	L
		mm	0.001mm	mm	0.001mm				mm	0.001mm				
22	S2B 12 N	20	+0.010 ~ -0.014	26.0	±0.015	52	38	13	42	±0.15	M6	5.3	20	0.025
26	S2B 16 N	20	+0.010 ~ -0.014	28.0	±0.015	56	40	13	46	±0.15	M6	5.3	22	0.060
32	S2B 20 N	25	+0.010 ~ -0.014	35.0	±0.015	70	50	15	58	±0.20	M8	6.6	28	0.098
40	S2B 25 N	30	+0.010 ~ -0.014	40.0	±0.015	80	60	18	68	±0.15	M8	6.6	40	0.125
47	S2B 30 N	35	+0.010 ~ -0.014	44.0	±0.015	88	70	18	76	±0.15	M8	6.6	48	0.140
62	S2B 40 N	45	+0.010 ~ -0.014	54.0	±0.015	108	85	22	94	±0.15	M10	8.5	56	0.080
75	S2B 50 N	50	+0.010 ~ -0.014	67.5	±0.015	135	102	27	116	±0.15	M12	10.5	72	0.400

SERIES S2B LME..

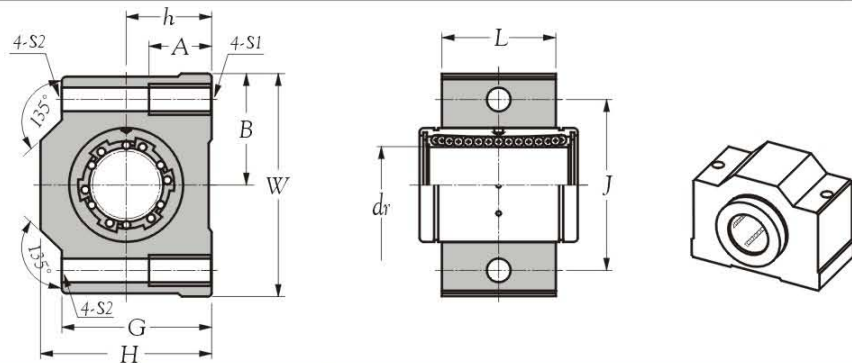

Boundary dimensions d mm	Bearing number	Principal dimensions										Mass kg (approx.)		
		h		B		W	H	A	J		S1		S2	L
		mm	0.001mm	mm	0.001mm				mm	0.001mm				
22	S2B 12 N + LME 12 UU AS	20	+0.010 ~ -0.014	26.0	±0.015	52	38	13	42	±0.15	M6	5.3	20	0.025
26	S2B 16 N + LME 16 UU AS	20	+0.010 ~ -0.014	28.0	±0.015	56	40	13	46	±0.15	M6	5.3	22	0.060
32	S2B 20 N + LME 20 UU AS	25	+0.010 ~ -0.014	35.0	±0.015	70	50	15	58	±0.20	M8	6.6	28	0.098
40	S2B 25 N + LME 25 UU AS	30	+0.010 ~ -0.014	40.0	±0.015	80	60	18	68	±0.15	M8	6.6	40	0.125
47	S2B 30 N + LME 30 UU AS	35	+0.010 ~ -0.014	44.0	±0.015	88	70	18	76	±0.15	M8	6.6	48	0.140
62	S2B 40 N + LME 40 UU AS	45	+0.010 ~ -0.014	54.0	±0.015	108	85	22	94	±0.15	M10	8.5	56	0.080
75	S2B 50 N + LME 50 UU AS	50	+0.010 ~ -0.014	67.5	±0.015	135	102	27	116	±0.15	M12	10.5	72	0.400

Technical supplement

	Cages	Precision	Grease
	Steel - Nil		
	Polymid - Nil	Normal (ISO)	Nil
	Brass - Nil		

Remark: If you have more inquiry of technical, please inquire
NIKO web-site: [Http://www.nipponkodobearings.com](http://www.nipponkodobearings.com)

ALUMINIUM HOUSINGS
SERIES **SBT..AS**

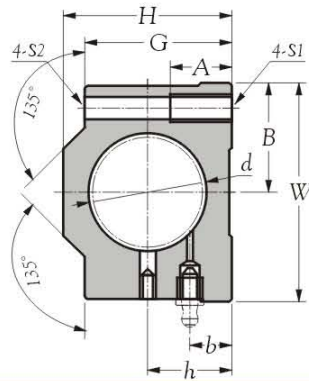

Boundary dimensions <i>d</i> mm	Bearing number	Principal dimensions											
		<i>h</i>		<i>B</i>		<i>W</i>	<i>H</i>	<i>b</i>	<i>A</i>	<i>J</i>		<i>S1</i>	<i>S2</i>
		mm	tolerance	mm	tolerance	mm	mm	mm	mm	mm	mm	mm	mm
22	SBT 12 AS	18	+0.010 ~ -0.014	21.5	±0.015	43	35	8	11	32	±0.15	M5	4.3
26	SBT 16 AS	22	+0.010 ~ -0.014	26.5	±0.015	53	42	12	13	40	±0.15	M6	5.3
32	SBT 20 AS	25	+0.008 ~ -0.016	30.0	±0.010	60	50	13	18	45	±0.15	M8	6.6
40	SBT 25 AS	30	+0.008 ~ -0.016	39.0	±0.010	78	60	15	22	60	±0.15	M10	8.4
47	SBT 30 AS	35	+0.008 ~ -0.016	43.5	±0.010	87	70	16	22	68	±0.15	M10	8.4
62	SBT 40 AS	45	+0.008 ~ -0.016	54.0	±0.010	108	90	26	26	86	±0.15	M12	10.5
75	SBT 50 AS	50	+0.005 ~ -0.016	66.0	±0.015	132	101	22	34	108	±0.15	M14	13.5

SERIES **SBT LME..**

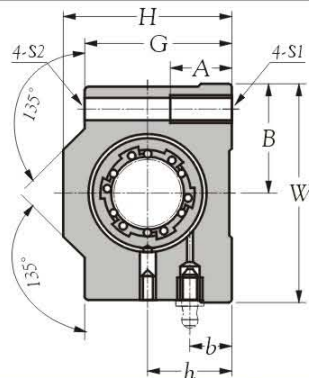

Boundary dimensions <i>d</i> mm	Bearing number	Principal dimensions											
		<i>h</i>		<i>B</i>		<i>W</i>	<i>H</i>	<i>b</i>	<i>A</i>	<i>J</i>		<i>S1</i>	<i>S2</i>
		mm	tolerance	mm	tolerance	mm	mm	mm	mm	mm	mm	mm	mm
22	SBT 12 AS + LME 12 UU AS	18	+0.010 ~ -0.014	21.5	±0.015	43	35	8	11	32	±0.15	M5	4.3
26	SBT 16 AS + LME 16 UU AS	22	+0.010 ~ -0.014	26.5	±0.015	53	42	12	13	40	±0.15	M6	5.3
32	SBT 20 AS + LME 20 UU AS	25	+0.008 ~ -0.016	30.0	±0.010	60	50	13	18	45	±0.15	M8	6.6
40	SBT 25 AS + LME 25 UU AS	30	+0.008 ~ -0.016	39.0	±0.010	78	60	15	22	60	±0.15	M10	8.4
47	SBT 30 AS + LME 30 UU AS	35	+0.008 ~ -0.016	43.5	±0.010	87	70	16	22	68	±0.15	M10	8.4
62	SBT 40 AS + LME 40 UU AS	45	+0.008 ~ -0.016	54.0	±0.010	108	90	26	26	86	±0.15	M12	10.5
75	SBT 50 AS + LME 50 UU AS	50	+0.005 ~ -0.016	66.0	±0.015	132	101	22	34	108	±0.15	M14	13.5

Technical supplement

	Cages	Precision	Grease
	Steel - Nil		
	Polymid - Nil	Normal (ISO)	Nil
	Brass - Nil		

Remark: If you have more inquiry of technical, please inquire
NIKO web-site: <http://www.nipponkodobearings.com>

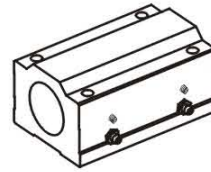
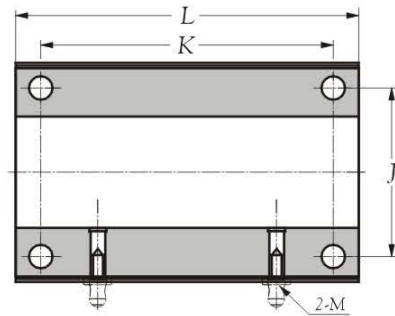

	Principal dimensions				Mass kg(s). (approx.)
	K tolerance mm	L	M	G	
56	±0.10	70	M6X1	31.0	0.170
64	±0.15	78	M6X1	37.0	0.310
76	±0.15	96	M6X1	44.0	0.486
94	±0.15	122	M8X1	52.5	0.630
106	±0.15	142	M8X1	62.5	0.760
124	±0.15	166	M8X1	80.0	0.980
160	±0.15	212	M8X1	88.0	2.360

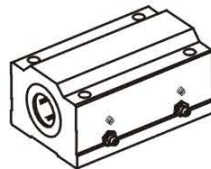
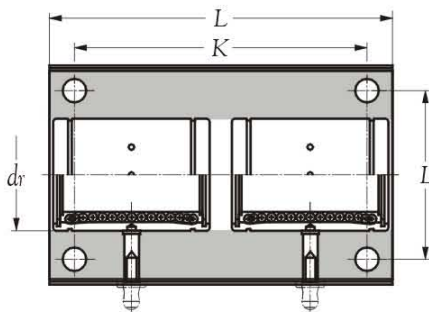

	Principal dimensions				Mass kg(s). (approx.)
	K tolerance mm	L	M	G	
56	±0.10	70	M6X1	31.0	0.170
64	±0.15	78	M6X1	37.0	0.310
76	±0.15	96	M6X1	44.0	0.486
94	±0.15	122	M8X1	52.5	0.630
106	±0.15	142	M8X1	62.5	0.760
124	±0.15	166	M8X1	80.0	0.980
160	±0.15	212	M8X1	88.0	2.360



NOTE



LINK
AUTOMATION TECHNOLOGY





TRACK ROLLER BEARINGS TECHNICAL TABLES

TECHNICAL INFORMATION		PAGES FOR REFER
		37 ~ 46
1.	BEARING MATERIALS	37
2.	SHIELDS AND SEALS	37 ~ 38
3.	BEARING TOLERANCES	38 ~ 41
4.	BEARING FITS	41 ~ 42
5.	BEARING INTERNAL CLEARANCE	43
6.	LUBRICATION	43
7.	LOAD RATING AND LIFE	44
8.	BEARING HANDLING	45
9.	ALLOWABLE SPEED	45 ~ 46

1. Bearing materials

The internal design of **NIKO** track rollers is the same as in single row or Double-row Angular Contact Ball Bearings.

The units can carry axial loads in both directions and, due to the thickness of the outer ring, large radial loads.

The standard products are produced from high quality bearing steel, with a hardness of 58 to 62 HRC. Some types are also available in stainless steel (440C) with hardness >58 HRC.

The track rollers contained in this catalogue are produced with standard tolerances (ISO 492) and standard clearance (CN).

The track rollers are produced in two distinct families. Cylindrical or crowned outer ring and profiled outer ring.

These track rollers are available in single and double row design. They are available with straight cylindrical OD or crowned profile OD. The crowned OD is used to reduce the edge stresses caused by possible misalignment errors. The cylindrical OD can provide increased support due to the longer contact profile.

These products are used typically on flat surfaces. Some of the most common applications are:

- transfer rolls
- idler rollers
- Support rollers
- Straightening rolls

2. Shields and seals

2.1 Types

2.1.1 Track rollers LR 2..NPP, LR 2..RRU

These single row ball track rollers are available in two different versions.

- LR2..NPP: cylindrical OD, with contact seals protected by a metal shield.
- LR2..RRU: crowned OD with contact seals protected by a metal shield, inner ring with increased width to allow additional lubricant storage.

2.1.2 Track rollers LR 52-53..NPPU, LR 52-53..KDD

These are double rows angular contact ball track rollers. Due to their internal design, they can carry axial loads of large magnitude. They are available in two versions:

- LR52-53..NPPU: crowned OD, contact seals protected by a metal shield.
- LR52-53..KDD: cylindrical OD, with metal shields.

The track rollers with profiled outer ring are basically Double-rows Angular Contact Ball Bearings with a reinforced and profiled outer ring. The outer ring profile allows the units to operate on round shafts or other type of profiled raceways. The outer profile can have three different designs:

- Track rollers with gothic arch groove - type LFR
- Track rollers with "V" shaped groove - type RV
- Track rollers with "W" profile - type RM

Type RV and RW can be supplied with the pertinent mounting hardware. The largest portion of these products are used as linear guides.

2.2 Types

2.2.1 Track rollers LFR, mounting bolts and studs RC/RE

The track rollers series LFR can be used on round shafts with diameter from 4 mm to 50 mm. The contact between track roller gothic arch groove profile and shaft is on two points. This allows the units to carry loads in both axial and radial direction. The track rollers are available with either shields ZZ or contact seals 2RS.

2.2.2 Track rollers RV

The track rollers RV have a groove machined in the outer ring. The groove is “V” shaped with an included angle of 120 degrees. These units are predominantly used on shafts with diameters from 7 to 20 MM. The contact between track roller and shafts is on two points. In special cases, the units can run on profiled ways. The units are supplied with non contact shields.

2.2.3 Track rollers with “W” profile, type RM

The track rollers series RM have grooves machined in the outer ring of the unit with an included angle of 90 degree. They have been engineered to run on profiled steel elements that have identical shape. They can run on either the internal or the external surfaces of the outer ring.

They are available with either non-contacting shields ZZ or contact seals 2RS.

3. Bearing tolerances

3.1 Standard of tolerances

Track roller bearing "tolerances" or dimensional accuracy and running accuracy, are regulated by ISO and JIS standards (rolling bearing tolerances). For dimensional accuracy, these standards prescribe the tolerances necessary when installing bearings on shafts or in housings.

Running accuracy is defined as the allowable limits for bearing runout during operation.

Table 3.1 Comparison of tolerance classifications of national standards

Standard		Tolerance class				
Japanese industrial standard (JIS)	JIS	class 0,6X	class 6	class 5	class 4	class 2
International Organization for Standardization (ISO)	ISO	Normal class Class 6X	Class 6	Class 5	Class 4	Class 2
Deutsches Institut für Normung (DIN)	DIN	P0	P6	P5	P4	P2
American National Standards Institute (ANSI)	ANSI/ABMA	ABEC-1	ABEC-3	ABEC-5	ABEC-7	ABEC-9

3.2 Tolerances for radial bearings

Table 3.2 Inner rings

(Unit : μm)

Nominal bore diameter d		Single plane mean bore diameter deviation Δd_{mp}										Single radial plane bore diameter variation V_{dp}									
mm		class 0		class 6		class 5		class 4 ^①		class 2 ^②		diameter series 9					maxdiameter series 0.1				
over	incl.	high	low	high	low	high	low	high	low	high	low	class 0	class 6	class 5	class 4	class 2	class 0	class 6	class 5	class 4	class 2
		max.										max.					max.				
10	18	0	-8	0	-7	0	-5	0	-4	0	-2.5	10	9	5	4	2.5	8	7	4	3	2.5
18	30	0	-10	0	-8	0	-6	0	-5	0	-2.5	13	10	6	5	2.5	10	8	5	4	2.5
30	50	0	-12	0	-10	0	-8	0	-6	0	-2.5	15	13	8	6	2.5	12	10	6	5	2.5

Table 3.3 Inner rings

(Unit : μm)

Nominal bore diameter d		Single radial plane bore diameter variation V_{dp}					Mean single plane bore diameter variation V_{dmp}					Inner ring radial runout K_{ia}					Face runout with bore S_d		
mm		maxdiameter series 2,3,4					max.					max.					max.		
over	incl.	class 0	class 6	class 5	class 4	class 2	class 0	class 6	class 5	class 4	class 2	class 0	class 6	class 5	class 4	class 2	class 5	class 4	class 2
10	18	6	5	4	3	2.5	6	5	3	2.0	1.5	10	7	4	2.5	1.5	7.0	3.0	1.5
18	30	8	6	5	4	2.5	8	6	3	2.5	1.5	13	8	4	3.0	2.5	8.0	4.0	1.5
30	50	9	8	6	5	2.5	9	8	4	3.0	1.5	15	10	5	4.0	2.5	8.0	4.0	1.5

Table 3.4 Inner rings

(Unit : μm)

Nominal bore diameter d		Inner ring axial runout (with side) S_{ia} ^③			Inner ring width deviation ΔB_s								Inner ring width variation V_{Bs}						
mm		class 5	class 4	class 2	normal				modified ^③				max.						
over	incl.	high	low	high	low	high	low	high	low	high	low	high	low	high	low	high	low	high	low
10	18	7	3	1.5	0	-120	0	-80	0	-80	0	-250	0	-250	20	20	5	2.5	1.5
18	30	8	4	2.5	0	-120	0	-120	0	-120	0	-250	0	-250	20	20	5	2.5	1.5
30	50	8	4	2.5	0	-120	0	-120	0	-120	0	-380	0	-250	20	20	5	3.0	1.5

- Note: ① The dimensional difference Δd_s of bore diameter to applied for class 4 and 2 is the same as the tolerance of dimensional difference Δd_{mp} of average bore diameter. However, the dimensional difference is applied to diameter series 0, 1, 2, 3 and 4 against Class 4, and to all the diameter series against Class 2.
- ② To be applied for deep groove ball bearing and angular contact ball bearings.
- ③ To be applied for individual raceway rings manufactured for combined bearing use.

Symbols: Δd_{mp} : deviation of the mean bore diameter from the nominal ($\Delta d_{mp} = d_{mp} - d$),
 V_{dp} : bore diameter variation: difference between the largest and smallest single bore diameters in one plane,
 V_{dmp} : mean bore diameter variation: difference between the largest and smallest mean bore diameters of one ring or washer,
 K_{ia} : radial runout of assembled bearing inner ring and assembled bearing outer ring, respectively,
 S_d : side face runout with reference to bore (of inner ring),
 S_{ia} : side face runout of assembled bearing inner ring and assembled bearing outer ring, respectively,
 ΔB_s : deviation of single inner ring width or single outer ring width from the nominal ($\Delta B_s = B_s - B$ etc.)
 V_{Bs} : ring width variation: difference between the largest and smallest single widths of inner ring and of outer ring, respectively.

Table 3.5 Outer rings

(Unit : μm)

Nominal Outside diameter D mm		Single plane mean outside diameter deviation ΔD_{mp}										Single radial plane outside diameter variation V_{Dp}									
over	incl.	class 0		class 6		class 5		class 4 [Ⓢ]		class 2 [Ⓢ]		diameter series 9					maxdiameter series 0.1				
		high	low	high	low	high	low	high	low	high	low	high	low	high	low	high	low	high	low	high	low
6	18	0	-8	0	-7	0	-5	0	-4	0	-2.5	10	9	5	4	2.5	8	7	4	3	2.5
18	30	0	-9	0	-8	0	-6	0	-5	0	-4.0	12	10	6	5	4.0	9	8	5	4	4.0
30	50	0	-11	0	-9	0	-7	0	-6	0	-4.0	14	11	7	6	4.0	11	9	5	5	4.0
50	80	0	-13	0	-11	0	-9	0	-7	0	-4.0	16	14	9	7	4.0	13	11	7	5	4.0
80	120	0	-15	0	-13	0	-10	0	-8	0	-5.0	19	16	10	8	5.0	19	16	8	6	5.0

Table 3.6 Outer rings

(Unit : μm)

Nominal Outside diameter D mm		Single radial plane outside diameter variation V_{Dp}					Single radial plane outside diameter variation $V_{Dp}^{\text{Ⓢ}}$		Mean single plane outside diameter variation V_{Dmp}				
over	incl.	maxdiameter series 2.3.4					capped bearings diameter series						
		class 0	class 6	class 5	class 4	class 2	2,3,4 class 0	0,1,2,3,4 class 6	class 0	class 6	class 5	class 4	class 2
6	18	6	5	4	3	2.5	10	9	6	5	3	2.0	1.5
18	30	7	6	5	4	4.0	12	10	7	6	3	2.5	2.0
30	50	8	7	5	5	4.0	16	13	8	7	4	3.0	2.0
50	80	10	8	7	5	4.0	20	16	10	8	5	3.5	2.0
80	120	11	10	8	6	5.0	26	20	11	10	5	4.0	2.5

Symbols: ΔD_{mp} : deviation of the mean outside diameter from the nominal ($\Delta D_{mp}=D_{mp} - D$).
 V_{Dp} : outside diameter variation: difference between the largest and smallest single outside diameters in one plane.
 V_{Dmp} : mean outside diameter variation: difference between the largest and smallest mean outside diameters of one ring or washer.

Table 3.7 Outer rings

(Unit : μm)

Nominal Outside diameter D		Outer ring radial runout K_{ea}					Outside surface inclination S_D			Outside ring axial runout S_{ea} ^⑥			Outer ring width deviation ΔC_s	Outer ring width variation V_{cs}			
mm		class 0	class 6	class 5 max.	class 4	class 2	class 5	class 4 max.	class 2	class 5	class 4 max.	class 2	all type	class 0,6	class 5	class 4 max.	class 2
over	incl.																
6	18	15	8	5	3	1.5	8	4	1.5	8	5	1.5	Identical to ΔB_s of inner ring of same bearing	Identical to ΔB_s and V_{bs} of inner ring of same bearing	5	2.5	1.5
18	30	15	9	6	4	2.5	8	4	1.5	8	5	2.5			5	2.5	1.5
30	50	20	10	7	5	2.5	8	4	1.5	8	5	2.5			5	2.5	1.5
50	80	25	13	8	5	4.0	8	4	1.5	10	5	4.0			6	3.0	1.5
80	120	35	18	10	6	5.0	9	5	2.5	11	6	5.0			8	4.0	2.5

Note: ⑥ The dimensional difference ΔD_s of outer diameter to be applied for classes 4 and 2 is the same as the tolerance of dimensional difference ΔD_{mp} of average outer diameter. However, the dimensional difference is applied to diameter series 0,1,2,3 and 4 against Class 4, and also to all the diameter series against Class 2.

- ⑦ To be applied in case snap rings are not installed on the bearings.
- ⑧ To be applied for Track Roller Bearings.

Symbols: K_{ea} : radial runout of assembled bearing inner ring and assembled bearing outer ring, respectively.
 S_D : outside inclination variation: variation in inclination of outside cylindrical surface to outer ring side face.
 S_{ea} : side face runout of assembled bearing inner ring and assembled bearing outer ring, respectively.
 ΔC_s : deviation of single inner ring width or single outer ring width from the nominal ($\Delta B_s = B_s - B$ etc.)
 V_{cs} : ring width variation: difference between the largest and smallest single widths of inner ring and of outer ring, respectively.

4. Bearing fits

Track rollers are precision machine elements. These products must be very carefully handled before and during fitting. Their trouble-free operation depends largely on the care taken during fitting

4.1 Compatibility and miscibility

The anti-corrosive preservation oil used for rolling bearings is compatible and miscible with oils and greases with a mineral oil base. Compatibility should be checked if the following are used:

- synthetic lubricants
- thickeners other than lithium or lithium complex soaps.

If there is an incompatibility, the anti-corrosive oil should be washed out before greasing, particularly in the following cases:

- lubricants based on PTFE/alkoxyfluoroether
- lubricants with a polycarbamide thickener

and if

- the lubricant is changed
- the rolling bearings are contaminated.

If in doubt, please contact the relevant lubricant manufacturer.

4.2 Guidelines for fitting

- The assembly area must be kept clean and free from dust
- Protect bearings from dust, contaminants and moisture
 - contaminants have a detrimental influence on the running and operating life of rolling bearings
- Inspect the housing bore and shaft/axis seating for
 - dimensional and geometrical tolerances
 - cleanliness

- Lightly oil the bearing ring seating surfaces or rub with solid lubricant
- Do not cool the bearings excessively
 - Moisture due to condensation can lead to corrosion in the bearings and bearing seatings
- After fitting
 - charge ungreased rolling bearings with lubricant
 - check the correct functioning of the bearing arrangement.

4.3 Fitting tools

- Induction heating device (see figure below)
- Heating cupboard
 - heating up to + 80 °C

Mechanical or hydraulic press

- fitting sleeves should be used which cover the whole circumference of the bearing ring end faces
- Hammer and fitting sleeve
 - light hammer blows should be centrally directed on the fitting sleeve

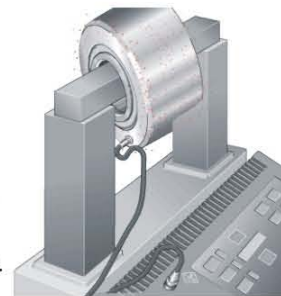

Heating with an induction heater

Note: Fitting forces must never be directed through the rolling elements. Direct blows on the bearing rings must be avoided.

4.4 Dismantling guidelines

- Dismantling should be taken into consideration in the original design of the bearing location
- If the bearings are to be reused:
 - direct blows on the bearing rings should be avoided
 - dismantling forces should not be applied through the rolling elements
 - bearings should be carefully cleaned once dismantled
 - do not use a concentrated or hard flame.

4.5 Fitting and dismantling of yoke type track rollers (ball type)

- If the tolerance zone is unfavourable: the bearing should be pressed into place using a fitting press
 - The inner ring must be fitted such that the pressing-in force is distributed uniformly on the end face of the inner ring.

Note: Fitting forces must not be directed through the rolling elements.

It must be ensured that the seals are not damaged during fitting.

- Track rollers must be secured axially according to the advice given.

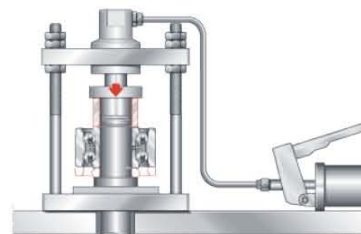

Fitting of the yoke type track roller using a fitting press

Note: Extraction forces must not be directed through the outer ring. This could damage the rolling elements and seals.

4.6 Fitting and dismantling of stud type track rollers (ball type)

Stud type track rollers are fitted and dismantled by methods similar to those used for yoke type track rollers (see figure below).

- Note: The tightening torques given in the dimension table must be observed. Only then can the permissible radial load be ensured. Screws and nuts of grade ≥ 8.8 must be used.

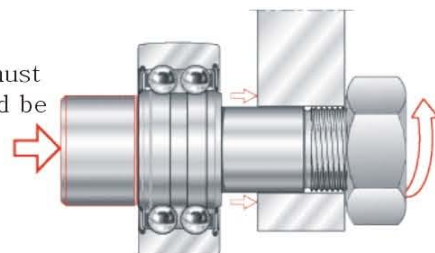

Fitting of a stud type track roller

5. Bearing internal clearance

Track Roller Bearing internal clearance (initial clearance) is the amount of internal clearance a bearing has before being installed on a shaft or in a housing. The internal clearance values for **NIKO** Track roller bearing classes are shown in tables 5.1

Table 5.1 Radial internal clearance of track roller bearings

(Unit : μm)

Nominal bore diameter d (mm)		C2		Normal		C3		C4	
over	incl.	min.	max.	min.	max.	min.	max.	min.	max.
-	10	6	12	8	15	15	22	22	30
10	18	6	12	8	15	15	24	30	40
18	30	6	12	10	20	20	32	40	55
30	50	8	14	14	25	25	40	55	75

6. Lubrication

6.1 Track rollers series LR 2..are supplied grease filled. (The lithium soap grease).

6.2 Track rollers series LR 52..are supplied grease filled. (The lithium soap grease) .

6.3 Track rollers LFR, mounting bolts and studs RC/RE

The units are supplied with lifetime grease lubrication

The size with an outside diameter 52 mm or greater have a lubrication hole in the inner ring.

To prevent mixing of greases with different characteristics, please insure to perform the

lubrication of the units with lubricants that have the same characteristics as the grease used

at the factory. Mounting bolts are available in both eccentric RE and concentric RC versions.

The eccentric bolts RE and RE..A1 allow the adjustment of the operating clearance.

Bolts of series RE..A1 and RC..A1 have facilities that enable relubrication of the track rollers.

The mounting bolts of series RC hare supplied with the pertinent washer, while the one of series RE have both washer and nut.

The units RC..A1 and RE..A1 also incorporate the grease fitting and its relative cover plug.

6.4 Track rollers RV

The units are supplied with lifetime lubrication.

6.5 Track rollers with “W” profile, type RM

The units are supplied with lifetime grease lubrication.

7. Load rating and life

If the track rollers operate on a flat surface/raceway, the outer ring deforms (fig.1)

When compared with a bearing mounted in a suitable housing, track rollers have the following characteristics:

- Modified load distribution

This is accounted for by using the load factors C_w and C_{ow} when calculating the life.

- Alternating bending stress on the outer ring

This is taken into account by the load coefficients F_{rperm} and F_{roperm} (see dimension tables). The stresses must not exceed the allowable limits.

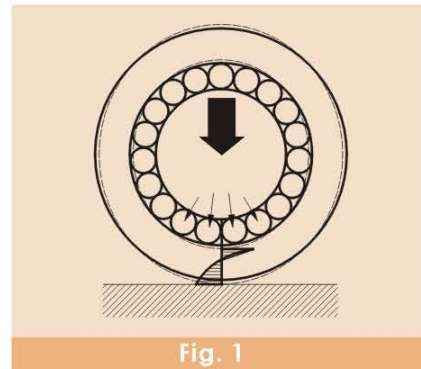

Fig. 1

7.1 Load ratings and life calculation

The dynamic load rating of the track roller is determined by the fatigue limit of the material. The life of the track roller is defined as the period of use before the appearance of fatigue. The ability of a track roller to carry dynamic loads is statistically derived.

7.1.1 Life calculation

The formula to calculate the nominal life is as follows:

$$L = \left(\frac{C_w}{P}\right)^3$$

$$L_h = \frac{833}{H \cdot n_{osz}} \left(\frac{C_w}{P}\right)^3$$

$$L_h = \frac{1666}{V_m} \left(\frac{C_w}{P}\right)^3$$

L = nominal life in 10^5 m reached by 90% of a statistically significant number of apparently identical bearing operating under the same loading condition before the onset of metal fatigue.

L_h [h] = nominal life in hours

C_w [N] = Dynamic load rating. Is the load that would yield a nominal life of 105 m.

P [N] = equivalent dynamic load

H [m] = stroke

n_{osz} [min^{-1}] = frequency of operation

V_m [m/min] = mean operating velocity

7.1.2 Radial dynamic limit load F_{rperm}

When selecting the product it is necessary to insure that no loading condition will exceed the allowable load.

8. Bearing handling

8.1 Storage

The bearings should be stored:

- in dry, clean rooms with the temperature as constant as possible
- at a relative humidity of max. 65%.

The storage period for greased and sealed bearings is limited by the shelf life of the grease.

8.2 Removal from packaging

Perspiration from handling leads to corrosion. Hands should be kept clean and dry and gloves worn if necessary.

Bearings should only be removed from their original packaging immediately before assembly. If only a few bearings are taken out of a multi-piece package preserved by volatile corrosion inhibitor paper, the package must be closed again immediately

- the protective vapour phase is only effective when the package is closed
- the bearings which have been taken out must be greased or oiled immediately.

9. Allowable speed

As bearing speed increases, the temperature of the bearing also increases due to friction heat generated in the bearing interior. If the temperature continues to rise and exceeds certain limits, the efficiency of the lubricant start to fail down drastically, and the bearing can no longer continue to operate in a stable manner. Therefore, the maximum speed at which it is possible for the bearing to continuously operate without the generation of excessive heat beyond specified limits, is called the allowable speed (r/min). The allowable speed of a bearing depends on the type of bearing, bearing dimensions, type of cage, load, lubricating conditions, and cooling conditions.

The allowable speeds listed in the bearing tables for grease and oil lubrication are for **NIKO** track roller under normal operating conditions, correctly installed, using the suitable lubricants with adequate supply and proper maintenance. Moreover, these values are based on normal load conditions ($P \leq 0.09C$, $F_a/F_r \leq 0.3$). For track roller with contact seals, the allowable speed is determined by the peripheral lip speed of the seal.

For track roller to be used under heavier than normal load conditions, the allowable speed values listed in the bearing tables must be multiplied by an adjustment factor. The adjustment factors f_L and f_C are given in Figs. 9.1 and 9.2.

Under such high speed operating conditions, when special care is taken, the standard allowable speeds given in the bearing tables can be adjusted upward. The maximum speed adjustment values, f_B , by which the bearing table speeds can be multiplied, are shown in Table 9.1. However, for any application requiring speeds in excess of the standard allowable speed, please consult **NIKO** Engineering.

Fig.9.1 Value of adjustment factor f_L depends on bearing load

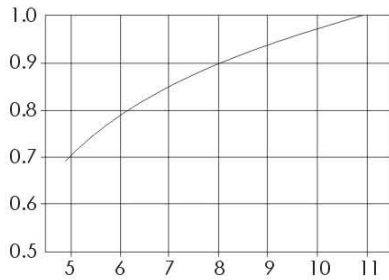
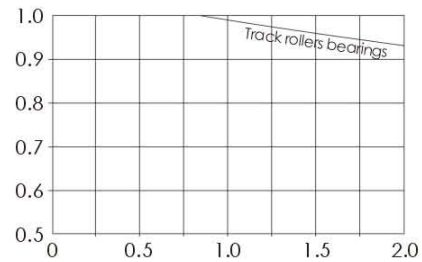

Fig.9.2 Value of adjustment factor f_c depends on combined load



18

Table 9.1 Adjustment factor, f_B , for allowable number of revolutions

Type of bearing	Adjustment factor f_B
Track rollers bearings	2.0



**TRACK ROLLER BEARINGS
DIMENSION TABLES**

TRACK ROLLER BEARINGS DOUBLE ROW
 SERIES **LR..NPP; LR..RRU**

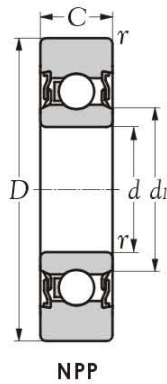

NPP

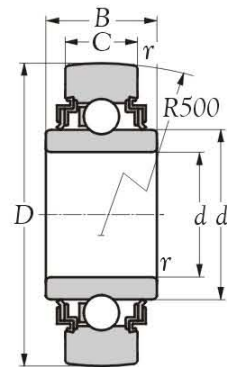

RRU

Boundary dimensions <i>d</i> mm	Bearing number	Boundary dimensions					Basic load ratings		Limiting speeds		Mass kg. (approx.)
		<i>D</i>	<i>C</i>	<i>r_s</i> mm	<i>d₁</i>	<i>B</i>	<i>C</i> N	<i>C₀</i>	grease rpm	oil	
10	LR 200 NPP	32	9	0.6	15.4	-	4,200	2,050	13,000	-	0.050
12	LR 201 NPP	35	10	0.6	17.1	-	5,500	2,600	15,000	-	0.050
15	LR 202 NPP	40	11	0.6	20.0	-	6,700	3,150	14,000	-	0.070
17	LR 203 NPP	47	12	0.6	22.5	-	9,100	4,200	11,000	-	0.110
20	LR 204 NPP	52	14	1.0	26.5	-	11,800	5,400	10,000	-	0.150
25	LR 205 NPP	62	15	1.0	30.3	-	14,900	6,800	9,000	-	0.230
30	LR 206 NPP	72	16	1.0	37.4	-	20,800	9,200	5,500	-	0.330
35	LR 207 NPP	80	17	1.1	42.4	-	26,100	11,400	4,500	-	0.400
45	LR 209 NPP	90	19	1.1	53.2	-	30,300	13,100	3,600	-	0.450
12	LR 201 RRU	35	10	0.6	18.5	15.0	5,500	3,000	15,000	-	0.070
15	LR 202 RRU	40	11	0.6	21.5	14.4	6,700	3,500	14,000	-	0.080



Technical supplement

Cages	Precision	Grease
Steel - Nil		
Polymid - Nil	Normal (ISO)	Nil
Brass - Nil		

Remark: If you have more inquiry of technical, please inquire
 NIKO web-site: [Http://www.nipponkodobearings.com](http://www.nipponkodobearings.com)

TRACK ROLLER BEARINGS DOUBLE ROW
 SERIES **LR 52..NPPU; LR 52..KDD**

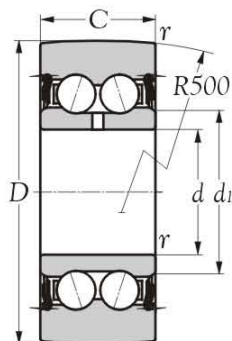

NPPU

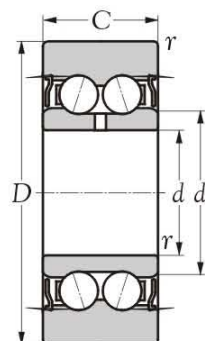

KDD

Boundary dimensions <i>d</i> mm	Bearing number	Boundary dimensions				Basic load ratings		Limiting speeds		Mass kg. (approx.)
		<i>D</i>	<i>C</i>	<i>r_s</i>	<i>d₁</i>	<i>C</i>	<i>C₀</i>	grease	oil	
		mm				N		rpm		
10	LR 5200 NPPU	32	14.0	0.6	15.4	6,500	3,900	8,000	-	0.070
12	LR 5201 NPPU	35	15.9	0.6	17.1	8,500	4,900	7,500	-	0.080
15	LR 5202 NPPU	40	15.9	0.6	20.0	10,100	5,900	7,000	-	0.110
17	LR 5203 NPPU	47	17.5	0.6	22.5	13,700	7,800	5,500	-	0.170
20	LR 5204 NPPU	52	20.6	1.0	26.5	17,700	10,000	5,000	-	0.230
25	LR 5205 NPPU	62	20.6	1.0	30.3	22,000	12,400	4,500	-	0.340
30	LR 5206 NPPU	72	23.8	1.0	37.4	30,700	20,400	3,500	-	0.510
35	LR 5207 NPPU	80	27.0	1.1	42.4	39,400	21,300	2,800	-	0.660
40	LR 5208 NPPU	85	30.2	1.1	48.4	45,500	24,300	2,500	-	0.750
10	LR 5200 KDD	32	14.0	0.6	15.4	6,500	3,900	11,000	-	0.070
12	LR 5201 KDD	35	15.9	0.6	17.1	8,500	4,900	10,000	-	0.080
15	LR 5202 KDD	40	15.9	0.6	20.0	10,100	5,900	10,000	-	0.110
17	LR 5203 KDD	47	17.5	0.6	22.5	13,700	7,800	7,500	-	0.170
20	LR 5204 KDD	52	20.6	1.0	26.5	17,700	10,000	7,000	-	0.230
25	LR 5205 KDD	62	20.6	1.0	30.3	22,000	12,400	6,500	-	0.340
30	LR 5206 KDD	72	23.8	1.0	37.4	30,700	20,400	5,000	-	0.510
35	LR 5207 KDD	80	27.0	1.1	42.4	39,400	21,300	3,900	-	0.660
40	LR 5208 KDD	85	30.2	1.1	48.4	45,500	24,300	3,500	-	0.750



Technical supplement

Cages	Precision	Grease
Steel - Nil	Normal (ISO)	Nil
Polymid - Nil		
Brass - Nil		

Remark: If you have more inquiry of technical, please inquire
 NIKO web-site: [Http://www.nipponkodobearings.com](http://www.nipponkodobearings.com)

TRACK ROLLER BEARINGS DOUBLE ROW
 SERIES **LR 53.. NPPU**

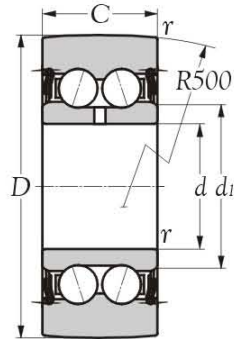

NPPU

Boundary dimensions <i>d</i> mm	Bearing number	Boundary dimensions				Basic load ratings		Limiting speeds		Mass kg(s). (approx.)
		<i>D</i>	<i>C</i>	<i>r_s</i>	<i>d₁</i>	<i>C</i> N	<i>C₀</i> N	grease rpm	oil rpm	
17	LR 5303 NPPU	52	22.2	1.0	23.5	19,300	10,600	4,700	-	0.210
20	LR 5304 NPPU	62	22.2	1.1	29.0	25,100	13,800	4,500	-	0.340
25	LR 5305 NPPU	72	25.4	1.1	34.4	34,300	18,600	3,900	-	0.500
30	LR 5306 NPPU	80	30.2	1.1	41.4	47,200	25,200	3,100	-	0.670
35	LR 5307 NPPU	90	34.9	1.5	47.7	59,800	31,400	2,500	-	0.970
40	LR 5308 NPPU	100	36.5	1.5	52.4	78,000	39,900	2,300	-	1.200



Technical supplement

Cages	Precision	Grease
Steel - Nil	Normal (ISO)	Nil
Polymid - Nil		
Brass - Nil		

Remark: If you have more inquiry of technical, please inquire
 NIKO web-site: [Http://www.nipponkodobearings.com](http://www.nipponkodobearings.com)

TRACK ROLLER BEARINGS DOUBLE ROW
 SERIES **LFR..2RS; LFR..2Z**

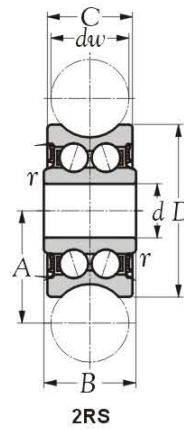
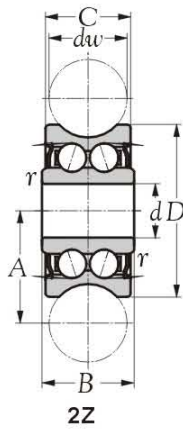

Boundary dimensions d mm	Bearing number		Boundary dimensions						Basic load ratings		Limiting speeds		Mass kg(s). (approx.)
			dw	D	C	B	A	rs	C	Co	grease	oil	
			mm						N		rpm		
4	LFR 50/4-4 2Z	LFR 50/4-4 2RS	4	13.0	6.0	7.0	7.55	0.2	1050	850	1150	1600	0.007
5	LFR 50/5-4 2Z	LFR 50/5-4 2RS	4	16.0	7.0	8.0	9.00	0.2	1200	860	1300	1780	0.009
5	LFR 50/5-6 2Z	LFR 50/5-6 2RS	6	17.0	7.0	8.0	10.50	0.2	1270	820	1300	1780	0.010
8	LFR 50/8-6 2Z	LFR 50/8-6 2RS	6	24.0	11.0	11.0	14.00	0.3	3670	2280	1300	4560	0.020
12	LFR 5201-10 2Z	LFR 5201-10 2RS	10	35.0	15.9	15.9	20.65	0.3	8500	5100	5100	10200	0.080
12	LFR 5301-10 2Z	LFR 5301-10 2RS	10	42.0	19.0	19.0	24.00	0.6	13000	7700	7500	14200	0.100
15	LFR 5302-10 2Z	LFR 5302-10 2RS	10	47.0	19.0	19.0	26.65	1.0	16200	9200	6200	18400	0.170
12	LFR 5201-12 2Z	LFR 5201-12 2RS	12	35.0	15.9	15.9	21.75	0.3	8400	5000	5100	10000	0.085
12	LFR 5201-14 2Z	LFR 5201-14 2RS	14	39.9	18.0	20.0	24.00	0.3	8900	5000	6700	12100	0.095
20	LFR 5204-16 2Z*	LFR 5204-16 2RS*	16	52.0	20.6	22.6	31.50	0.6	16800	9500	12100	16600	0.230
25	LFR 5206-20 2Z*	LFR 5206-20 2RS*	20	72.0	23.8	25.8	41.00	0.6	29500	16600	20700	33200	0.250
25	LFR 5206-25 2Z*	LFR 5206-25 2RS*	25	72.0	23.8	25.8	43.50	0.6	29200	16400	23100	32800	0.250
30	LFR 5207-30 2Z*	LFR 5207-30 2RS*	30	80.0	27.0	29.0	51.00	1.0	38000	20800	21400	36200	0.660
40	LFR 5208-40 2Z*	LFR 5208-40 2RS*	40	98.0	36.0	38.0	62.50	1.0	54800	29000	55000	58000	1.360
40	LFR 5308-50 2Z*	LFR 5308-50 2RS*	50	110.0	44.0	46.0	72.50	1.1	53000	39500	69000	79000	1.400

Remark: * Standard with lubrication hole on inner ring

Technical supplement

	Cages	Precision	Grease
Steel -	Nil		
Polymid -	Nil	Normal (ISO)	Nil
Brass -	Nil		

Remark: If you have more inquiry of technical, please inquire
 NIKO web-site: [Http://www.nipponkodobearings.com](http://www.nipponkodobearings.com)

TRACK ROLLER BEARINGS DOUBLE ROW
SERIES RC..; RE..

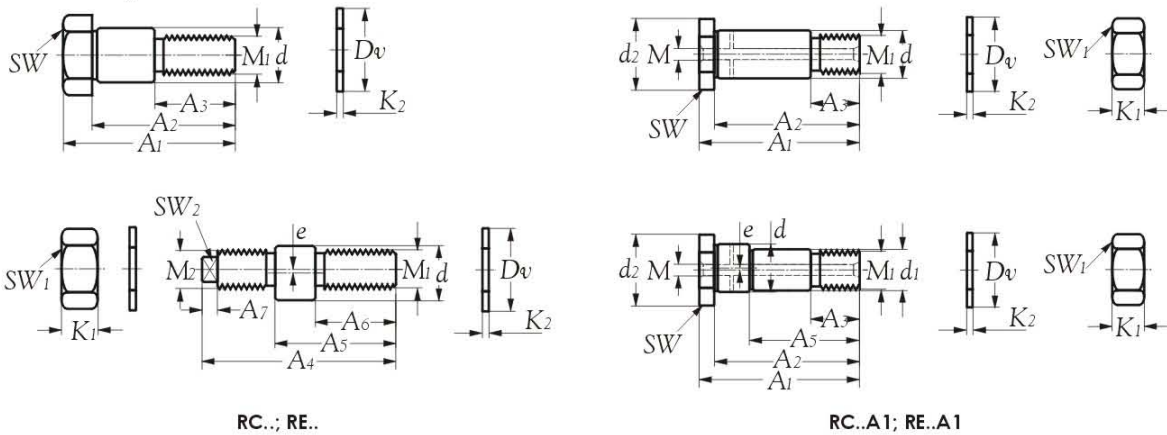

Bearing number	Boundary dimensions																	Mass kg(s). (approx.)		
	A ₁	A ₂	A ₃	A ₄	A ₅	A ₆	A ₇ h ₀	d ₁	d ₂	M ₁ mm	M ₂	K ₁	K ₂	D _v	SW	SW ₁	SW ₂		e	M
RC 5; RE 5-05	19.5	16.0	9.5	20.5	15.0	9.0	-	-	-	M4	M4	2.9	-	-	3	7	2	0.50	-	0.010
RC 8; RE 8-1	28.3	24.3	14.0	33.2	22.0	13.7	3.5	-	-	M8	M8x0.75	4.0	1.0	14	13	13	2	1.00	-	0.020
RC 12; RE 12-1	43.0	36.0	22.0	50.0	33.5	19.5	5.0	-	-	M10	M10	8.0	1.8	21	17	17	5	1.00	-	0.040
RC 12/M12; RE 12-1/M12	50.8	43.8	24.0	57.0	41.0	24.0	5.0	-	-	M12	M12	6.5	1.8	19	17	17	6	1.00	-	0.060
RC 15; RE 15-1	50.8	43.8	26.0	57.0	41.0	24.0	5.0	-	-	M12	M12	6.5	1.8	21	19	19	6	1.00	-	0.060
RC 12X45 A1; RE 12X45 A1	50.0	45.0	16.0	-	30.0	-	-	10	20	M10x1.5	-	8.0	2.0	21	17	17	6	0.75	5.9	0.040
RC 20X67 A1; RE 20X67 A1	75.0	67.0	23.0	-	45.0	-	-	17	30	M16x1.5	-	13.0	3.0	30	27	24	-	1.00	5.9	0.200
RC 25X82 A1; RE 25X82 A1	92.0	82.0	30.0	-	57.0	-	-	22	40	M20x1.5	-	16.0	3.0	37	36	30	-	1.00	5.9	0.400
RC 30X95 A1; RE 30X95 A1	107.0	95.0	32.0	-	67.0	-	-	27	45	M24x1.5	-	19.0	4.0	44	41	36	-	1.00	5.9	0.620
RC 40X107 A1; RE 40X107 A1	117.0	107.0	42.0	-	72.0	-	-	36	55	M30x1.5	-	24.0	4.0	56	46	46	-	1.00	5.9	1.100
RC 40X115 A1; RE 40X115 A1	125.0	115.0	42.0	-	72.0	-	-	36	55	M30x1.5	-	24.0	4.0	56	46	46	-	1.00	5.9	1.200

Technical supplement

Cages	Precision	Grease
Steel - Nil		
Polymid - Nil	Normal (ISO)	Nil
Brass - Nil		

Remark: If you have more inquiry of technical, please inquire
 NIKO web-site: [Http://www.nipponkodobearings.com](http://www.nipponkodobearings.com)

**TRACK ROLLER BEARINGS DOUBLE ROW
SERIES RV**

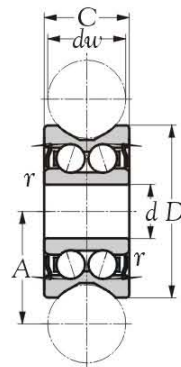

Boundary dimensions <i>d</i> mm	Bearing number	Boundary dimensions					Basic load ratings		Limiting speeds		Mass kg. (approx.)
		<i>d_w</i>	<i>D</i>	<i>C</i>	<i>A</i>	<i>r_s</i>	dynamic <i>C</i>	static <i>C₀</i>	grease rpm	oil rpm	
7	RV 20/7-10	10	22	11	14.50	0.3	2,450	1,620	2,350	4,150	0.017
8	RV 20/8-10	10	30	14	18.10	0.3	4,490	2,700	11,000	19,800	0.062
15	RV 202/15.38-10	10	38	17	22.25	0.5	7,290	4,550	10,200	17,900	0.086
15	RV 20/15.40-10	10	40	18	22.00	0.5	7,950	4,950	14,500	26,500	0.110
12	RV 201/12-20	20	41	20	28.00	0.3	8,180	5,100	17,200	31,500	0.130
15	RV 202/15.41-20	20	41	20	28.00	0.5	8,180	5,100	17,200	31,500	0.120
17	RV 203/17-20	20	58	25	35.00	0.5	16,580	9,200	47,000	86,000	0.325
20	RV 204/20.57-30	30	57	22	41.00	0.6	16,910	9,200	47,000	86,000	0.290
20	RV 204/20.58-30	30	58	25	41.00	0.6	16,790	9,200	40,000	72,000	0.310

Remark: * The unit contamination protection is provided by side shields 2Z.



Technical supplement

Cages	Precision	Grease
Steel - Nil	Normal (ISO)	Nil
Polymid - Nil		
Brass - Nil		

Remark: If you have more inquiry of technical, please inquire
NIKO web-site: [Http://www.nipponkodobearings.com](http://www.nipponkodobearings.com)

TRACK ROLLER BEARINGS DOUBLE ROW
 SERIES **RM..2Z; RM..2RS**

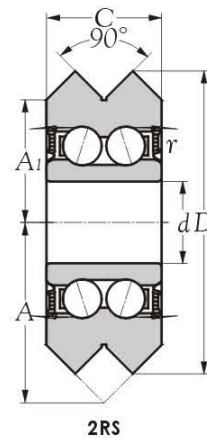
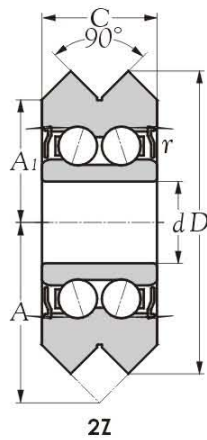

Boundary dimensions <i>d</i> mm	Bearing number		Boundary dimensions					Basic load ratings		Limiting speeds		Mass kg. (approx.)
	<i>D</i>	<i>A</i>	<i>C</i>	<i>A₁</i>	<i>r_s</i>	dynamic <i>C</i>	static <i>C₀</i>	grease rpm	oil rpm			
4.763	RM 1 2Z	RM 1 2RS	19.56	11.86	7.87	7.93	0.3	1,650	1,140	4,150	7,500	0.012
9.525	RM 2 2Z	RM 2 2RS	30.73	18.24	11.10	12.70	0.3	8,260	2,650	6,500	11,700	0.040
11.999	RM 3 2Z	RM 3 2RS	45.72	26.98	15.88	19.05	0.6	5,530	5,200	31,000	55,000	0.136
15.001	RM 4 2Z	RM 4 2RS	59.94	34.93	19.05	25.40	1.0	16,250	9,200	39,500	72,000	0.285



Technical supplement

Cages	Precision	Grease
Steel - Nil		
Polymid - Nil	Normal (ISO)	Nil
Brass - Nil		

Remark: If you have more inquiry of technical, please inquire
 NIKO web-site: [Http://www.nipponkodobearings.com](http://www.nipponkodobearings.com)

TRACK ROLLER BEARINGS DOUBLE ROW
SERIES RV..C; RV..E

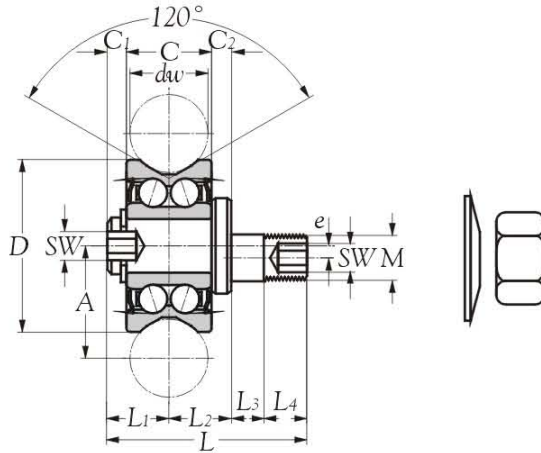

Boundary dimensions <i>dw</i> mm	Bearing number		Boundary dimensions													Basic load ratings		Limiting speeds		Mass kg. (approx.)
	concentric	eccentric	D	C	A	L	L ₁	L ₂	L ₃	L ₄	C ₁	C ₂	e	SW	M	dynamic	static	rpm		
	mm													C	C ₀	grease	oil			
10	RV 22 C	RV 22 E	22	11	14.5	26	8.5	8	4	5.5	3	3.0	1.5	3	M6	2,450	1,620	2,350	4,150	0.028
10	RV 30 C	RV 30 E	30	14	18.1	33	9.5	9	6	8.0	2	2.5	1.5	4	M8	4,490	2,700	11,000	19,800	0.069
10	RV 38 C	RV 38 E	38	17	22.3	42	11.0	11	8	12.0	3	2.5	2.0	5	M10	7,290	4,550	10,200	17,900	0.145
20	RV 41 C	RV 41 E	41	20	28.0	47	15.0	13	6	13.0	3	5.0	2.0	6	M12	8,180	5,100	17,200	31,500	0.190
20	RV 58 C	RV 58 E	58	25	35.0	59	17.0	19	11	13.0	6	4.0	2.5	6	M16	16,580	9,200	47,000	86,000	0.460

Remark: * Track rollers with integral studs are supplied with split washer and nut.
 * The unit contamination protection is provided by side shields 2Z.

Technical supplement

	Cages	Precision	Grease
Steel -	Nil		
Polymid -	Nil	Normal (ISO)	Nil
Brass -	Nil		

Remark: If you have more inquiry of technical, please inquire
 NIKO web-site: [Http://www.nipponkodobearings.com](http://www.nipponkodobearings.com)

TRACKROLLERBEARINGS DOUBLEROW
SERIES RPC; RPE

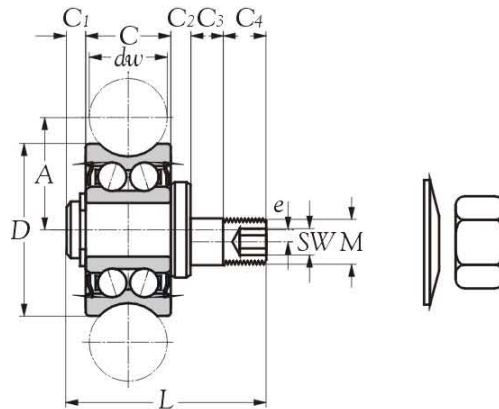

Boundary dimensions <i>dw</i> mm	Bearing number		Boundary dimensions											Basic load ratings		Limiting speeds		Mass kg. (approx.)
	concentric	eccentric	D	C	A	L	C ₁	C ₂	C ₃	C ₄	e	SW	M	dynamic N	static N	rpm		
	mm											C	C ₀	grease	oil			
6	RPC 17	RPE 17	17	7.0	10.50	23	1.5	1.5	5	5.5	0.50	2.5	M5	1,250	850	1,250	1,700	0.015
6	RPC 24	RPE 24	24	11.0	14.00	29	3.0	2.0	6	7.0	0.50	4.0	M8	3,500	2,200	1,250	4,350	0.042
10	RPC 35	RPE 35	35	15.9	20.65	44	3.2	2.0	10	13.0	0.75	5.0	M10	8,100	8,100	4,900	9,700	0.120

Remark: * Track rollers with integral studs are supplied with split washer and nut.



Technical supplement

Cages	Precision	Grease
Steel - Nil		
Polymid - Nil	Normal (ISO)	Nil
Brass - Nil		

Remark: If you have more inquiry of technical, please inquire
 NIKO web-site: [Http://www.nipponkodobearings.com](http://www.nipponkodobearings.com)

TRACK ROLLER BEARINGS DOUBLE ROW
SERIES RA..A

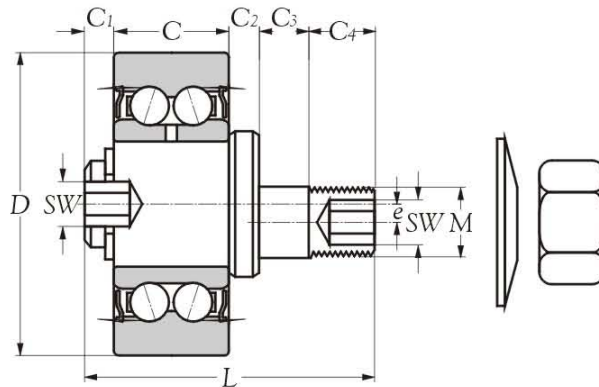

Bearing number	Boundary dimensions										Basic load ratings		Limiting speeds		Mass kg. (approx.)
	D	C	L	C ₁	C ₂	C ₃	C ₄	e	SW	M	C	C ₀	grease	oil	
mm											N		rpm		
RA 35 A	35	15.9	42	2.1	5	6.0	13	1.0	5	M 12	8,100	4,900	4,900	9,700	0.150
RA 52 A	52	22.2	57	3.3	8	9.5	14	1.5	6	M 16	16,000	9,100	11,500	15,800	0.345

Remark: * Track rollers with integral studs are supplied with split washer and nut.
 * The unit contamination protection is provided by side shields 2Z.

Technical supplement

	Cages	Precision	Grease
Steel -	Nil		
Polymid -	Nil	Normal (ISO)	
Brass -	Nil		Nil

Remark: If you have more inquiry of technical, please inquire
 NIKO web-site: [Http://www.nipponkodobearings.com](http://www.nipponkodobearings.com)

NIKO®

NIPPON KODO
AUTOMATION TECHNOLOGY

NIPPON KODO CO., LTD.
OSAKA-JAPAN



Brand Promise!



LINEAR MOTION 2012



FAIT GROUP SPA

VIA SCARPETTINI, 367-369
59013 OSTE MONTEMURLO (PO)
ITALY
TEL: +39 0574 68121
FAX: +39 0574 681262
E-MAIL: INFO@FAITGROUP.IT
WWW.FAITGROUP.IT

**NIPPON KODO AUTOMATION
TECHNOLOGY CO. LTD.**

ROOM 205, GRANDEUR IMAZATO BLDG.
NO. 1-4, 4-CHOME, IMAZATO,
NAGAKAKYO-CITY 617-0814, KYOTO, JAPAN
TEL: 81-75-959-0221
FAX: 81-75-959-0222
E-MAIL: NIKO@NIPPONKODOJAPAN.COM
WWW.NIPPONKODOBEARINGS.CO.JP