

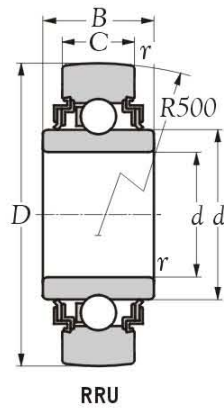

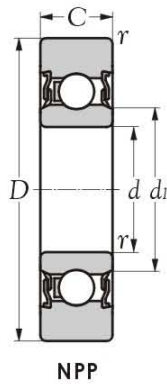

**TRACK ROLLER BEARINGS
DIMENSION TABLES**

TRACK ROLLER BEARINGS DOUBLE ROW
 SERIES **LR..NPP; LR..RRU**



Boundary dimensions <i>d</i> mm	Bearing number	Boundary dimensions					Basic load ratings		Limiting speeds		Mass kg. (approx.)
		<i>D</i>	<i>C</i>	<i>r_s</i> mm	<i>d₁</i>	<i>B</i>	<i>C</i> dynamic N	<i>C₀</i> static	grease rpm	oil	
10	LR 200 NPP	32	9	0.6	15.4	-	4,200	2,050	13,000	-	0.050
12	LR 201 NPP	35	10	0.6	17.1	-	5,500	2,600	15,000	-	0.050
15	LR 202 NPP	40	11	0.6	20.0	-	6,700	3,150	14,000	-	0.070
17	LR 203 NPP	47	12	0.6	22.5	-	9,100	4,200	11,000	-	0.110
20	LR 204 NPP	52	14	1.0	26.5	-	11,800	5,400	10,000	-	0.150
25	LR 205 NPP	62	15	1.0	30.3	-	14,900	6,800	9,000	-	0.230
30	LR 206 NPP	72	16	1.0	37.4	-	20,800	9,200	5,500	-	0.330
35	LR 207 NPP	80	17	1.1	42.4	-	26,100	11,400	4,500	-	0.400
45	LR 209 NPP	90	19	1.1	53.2	-	30,300	13,100	3,600	-	0.450
12	LR 201 RRU	35	10	0.6	18.5	15.0	5,500	3,000	15,000	-	0.070
15	LR 202 RRU	40	11	0.6	21.5	14.4	6,700	3,500	14,000	-	0.080



Technical supplement

Cages	Precision	Grease
Steel - Nil		
Polymid - Nil	Normal (ISO)	Nil
Brass - Nil		

Remark: If you have more inquiry of technical, please inquire
 NIKO web-site: [Http://www.nipponkodobearings.com](http://www.nipponkodobearings.com)

TRACK ROLLER BEARINGS DOUBLE ROW
 SERIES **LR 52..NPPU; LR 52..KDD**

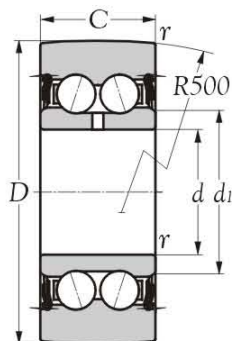

NPPU

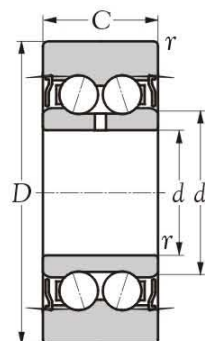

KDD

Boundary dimensions <i>d</i> mm	Bearing number	Boundary dimensions				Basic load ratings		Limiting speeds		Mass kg. (approx.)
		<i>D</i>	<i>C</i>	<i>r_s</i>	<i>d₁</i>	<i>C</i>	<i>C₀</i>	grease	oil	
		mm				N		rpm		
10	LR 5200 NPPU	32	14.0	0.6	15.4	6,500	3,900	8,000	-	0.070
12	LR 5201 NPPU	35	15.9	0.6	17.1	8,500	4,900	7,500	-	0.080
15	LR 5202 NPPU	40	15.9	0.6	20.0	10,100	5,900	7,000	-	0.110
17	LR 5203 NPPU	47	17.5	0.6	22.5	13,700	7,800	5,500	-	0.170
20	LR 5204 NPPU	52	20.6	1.0	26.5	17,700	10,000	5,000	-	0.230
25	LR 5205 NPPU	62	20.6	1.0	30.3	22,000	12,400	4,500	-	0.340
30	LR 5206 NPPU	72	23.8	1.0	37.4	30,700	20,400	3,500	-	0.510
35	LR 5207 NPPU	80	27.0	1.1	42.4	39,400	21,300	2,800	-	0.660
40	LR 5208 NPPU	85	30.2	1.1	48.4	45,500	24,300	2,500	-	0.750
10	LR 5200 KDD	32	14.0	0.6	15.4	6,500	3,900	11,000	-	0.070
12	LR 5201 KDD	35	15.9	0.6	17.1	8,500	4,900	10,000	-	0.080
15	LR 5202 KDD	40	15.9	0.6	20.0	10,100	5,900	10,000	-	0.110
17	LR 5203 KDD	47	17.5	0.6	22.5	13,700	7,800	7,500	-	0.170
20	LR 5204 KDD	52	20.6	1.0	26.5	17,700	10,000	7,000	-	0.230
25	LR 5205 KDD	62	20.6	1.0	30.3	22,000	12,400	6,500	-	0.340
30	LR 5206 KDD	72	23.8	1.0	37.4	30,700	20,400	5,000	-	0.510
35	LR 5207 KDD	80	27.0	1.1	42.4	39,400	21,300	3,900	-	0.660
40	LR 5208 KDD	85	30.2	1.1	48.4	45,500	24,300	3,500	-	0.750



Technical supplement

Cages	Precision	Grease
Steel - Nil	Normal (ISO)	Nil
Polymid - Nil		
Brass - Nil		

Remark: If you have more inquiry of technical, please inquire
 NIKO web-site: [Http://www.nipponkodobearings.com](http://www.nipponkodobearings.com)

TRACK ROLLER BEARINGS DOUBLE ROW
 SERIES **LR 53.. NPPU**

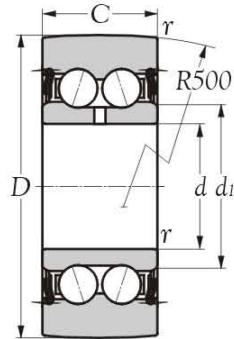

NPPU

Boundary dimensions <i>d</i> mm	Bearing number	Boundary dimensions				Basic load ratings		Limiting speeds		Mass kg(s). (approx.)
		<i>D</i>	<i>C</i>	<i>r_s</i>	<i>d₁</i>	<i>C</i> dynamic	<i>C₀</i> static	grease rpm	oil	
17	LR 5303 NPPU	52	22.2	1.0	23.5	19,300	10,600	4,700	-	0.210
20	LR 5304 NPPU	62	22.2	1.1	29.0	25,100	13,800	4,500	-	0.340
25	LR 5305 NPPU	72	25.4	1.1	34.4	34,300	18,600	3,900	-	0.500
30	LR 5306 NPPU	80	30.2	1.1	41.4	47,200	25,200	3,100	-	0.670
35	LR 5307 NPPU	90	34.9	1.5	47.7	59,800	31,400	2,500	-	0.970
40	LR 5308 NPPU	100	36.5	1.5	52.4	78,000	39,900	2,300	-	1.200



Technical supplement

Cages	Precision	Grease
Steel - Nil	Normal (ISO)	
Polymid - Nil		
Brass - Nil		

Remark: If you have more inquiry of technical, please inquire
 NIKO web-site: [Http://www.nipponkodobearings.com](http://www.nipponkodobearings.com)

TRACK ROLLER BEARINGS DOUBLE ROW
 SERIES **LFR..2RS; LFR..2Z**

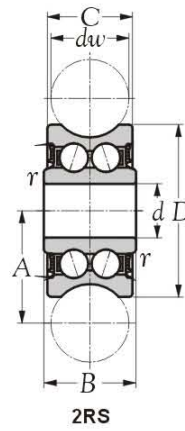
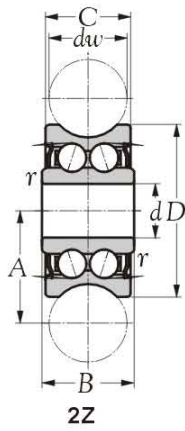

Boundary dimensions d mm	Bearing number		Boundary dimensions						Basic load ratings		Limiting speeds		Mass kg(s). (approx.)
			dw	D	C	B	A	rs	C	Co	grease	oil	
			mm						N		rpm		
4	LFR 50/4-4 2Z	LFR 50/4-4 2RS	4	13.0	6.0	7.0	7.55	0.2	1050	850	1150	1600	0.007
5	LFR 50/5-4 2Z	LFR 50/5-4 2RS	4	16.0	7.0	8.0	9.00	0.2	1200	860	1300	1780	0.009
5	LFR 50/5-6 2Z	LFR 50/5-6 2RS	6	17.0	7.0	8.0	10.50	0.2	1270	820	1300	1780	0.010
8	LFR 50/8-6 2Z	LFR 50/8-6 2RS	6	24.0	11.0	11.0	14.00	0.3	3670	2280	1300	4560	0.020
12	LFR 5201-10 2Z	LFR 5201-10 2RS	10	35.0	15.9	15.9	20.65	0.3	8500	5100	5100	10200	0.080
12	LFR 5301-10 2Z	LFR 5301-10 2RS	10	42.0	19.0	19.0	24.00	0.6	13000	7700	7500	14200	0.100
15	LFR 5302-10 2Z	LFR 5302-10 2RS	10	47.0	19.0	19.0	26.65	1.0	16200	9200	6200	18400	0.170
12	LFR 5201-12 2Z	LFR 5201-12 2RS	12	35.0	15.9	15.9	21.75	0.3	8400	5000	5100	10000	0.085
12	LFR 5201-14 2Z	LFR 5201-14 2RS	14	39.9	18.0	20.0	24.00	0.3	8900	5000	6700	12100	0.095
20	LFR 5204-16 2Z*	LFR 5204-16 2RS*	16	52.0	20.6	22.6	31.50	0.6	16800	9500	12100	16600	0.230
25	LFR 5206-20 2Z*	LFR 5206-20 2RS*	20	72.0	23.8	25.8	41.00	0.6	29500	16600	20700	33200	0.250
25	LFR 5206-25 2Z*	LFR 5206-25 2RS*	25	72.0	23.8	25.8	43.50	0.6	29200	16400	23100	32800	0.250
30	LFR 5207-30 2Z*	LFR 5207-30 2RS*	30	80.0	27.0	29.0	51.00	1.0	38000	20800	21400	36200	0.660
40	LFR 5208-40 2Z*	LFR 5208-40 2RS*	40	98.0	36.0	38.0	62.50	1.0	54800	29000	55000	58000	1.360
40	LFR 5308-50 2Z*	LFR 5308-50 2RS*	50	110.0	44.0	46.0	72.50	1.1	53000	39500	69000	79000	1.400

Remark: * Standard with lubrication hole on inner ring

Technical supplement

	Cages	Precision	Grease
	Steel - Nil		
	Polymid - Nil	Normal (ISO)	Nil
	Brass - Nil		

Remark: If you have more inquiry of technical, please inquire
 NIKO web-site: [Http://www.nipponkodobearings.com](http://www.nipponkodobearings.com)

TRACK ROLLER BEARINGS DOUBLE ROW
SERIES RC..; RE..

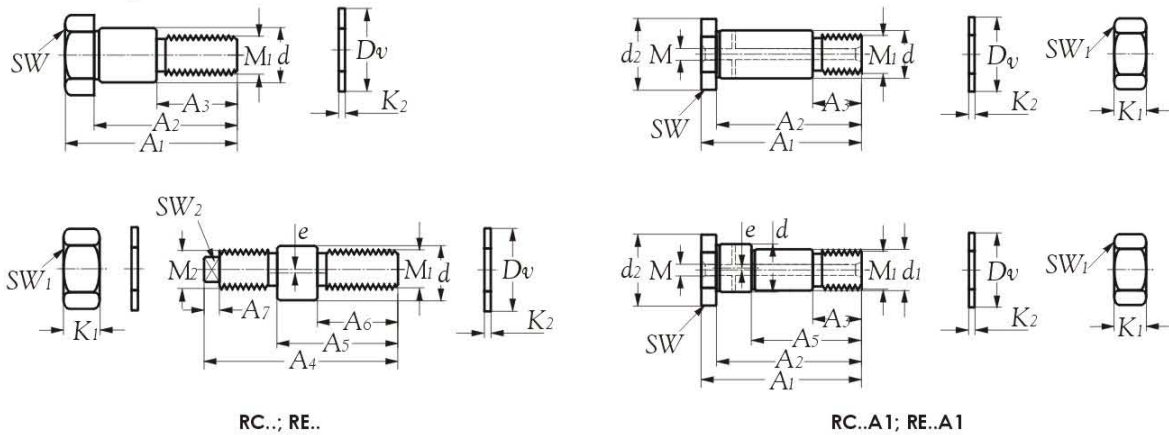

Bearing number	Boundary dimensions																	Mass kg(s). (approx.)		
	A ₁	A ₂	A ₃	A ₄	A ₅	A ₆	A ₇ h ₀	d ₁	d ₂	M ₁ mm	M ₂	K ₁	K ₂	D _v	SW	SW ₁	SW ₂		e	M
RC 5; RE 5-05	19.5	16.0	9.5	20.5	15.0	9.0	-	-	-	M4	M4	2.9	-	-	3	7	2	0.50	-	0.010
RC 8; RE 8-1	28.3	24.3	14.0	33.2	22.0	13.7	3.5	-	-	M8	M8x0.75	4.0	1.0	14	13	13	2	1.00	-	0.020
RC 12; RE 12-1	43.0	36.0	22.0	50.0	33.5	19.5	5.0	-	-	M10	M10	8.0	1.8	21	17	17	5	1.00	-	0.040
RC 12/M12; RE 12-1/M12	50.8	43.8	24.0	57.0	41.0	24.0	5.0	-	-	M12	M12	6.5	1.8	19	17	17	6	1.00	-	0.060
RC 15; RE 15-1	50.8	43.8	26.0	57.0	41.0	24.0	5.0	-	-	M12	M12	6.5	1.8	21	19	19	6	1.00	-	0.060
RC 12X45 A1; RE 12X45 A1	50.0	45.0	16.0	-	30.0	-	-	10	20	M10x1.5	-	8.0	2.0	21	17	17	6	0.75	5.9	0.040
RC 20X67 A1; RE 20X67 A1	75.0	67.0	23.0	-	45.0	-	-	17	30	M16x1.5	-	13.0	3.0	30	27	24	-	1.00	5.9	0.200
RC 25X82 A1; RE 25X82 A1	92.0	82.0	30.0	-	57.0	-	-	22	40	M20x1.5	-	16.0	3.0	37	36	30	-	1.00	5.9	0.400
RC 30X95 A1; RE 30X95 A1	107.0	95.0	32.0	-	67.0	-	-	27	45	M24x1.5	-	19.0	4.0	44	41	36	-	1.00	5.9	0.620
RC 40X107 A1; RE 40X107 A1	117.0	107.0	42.0	-	72.0	-	-	36	55	M30x1.5	-	24.0	4.0	56	46	46	-	1.00	5.9	1.100
RC 40X115 A1; RE 40X115 A1	125.0	115.0	42.0	-	72.0	-	-	36	55	M30x1.5	-	24.0	4.0	56	46	46	-	1.00	5.9	1.200



Technical supplement

Cages	Precision	Grease
Steel - Nil		
Polymid - Nil	Normal (ISO)	Nil
Brass - Nil		

Remark: If you have more inquiry of technical, please inquire
 NIKO web-site: [Http://www.nipponkodobearings.com](http://www.nipponkodobearings.com)

TRACK ROLLER BEARINGS DOUBLE ROW
SERIES RV

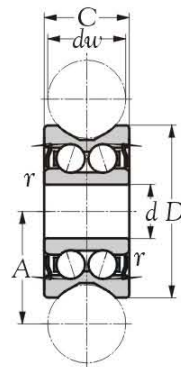

Boundary dimensions <i>d</i> mm	Bearing number	Boundary dimensions					Basic load ratings		Limiting speeds		Mass kg. (approx.)
		<i>d_w</i>	<i>D</i>	<i>C</i>	<i>A</i>	<i>r_s</i>	C dynamic	<i>C₀</i> static	grease	oil	
		mm					N		rpm		
7	RV 20/7-10	10	22	11	14.50	0.3	2,450	1,620	2,350	4,150	0.017
8	RV 20/8-10	10	30	14	18.10	0.3	4,490	2,700	11,000	19,800	0.062
15	RV 202/15.38-10	10	38	17	22.25	0.5	7,290	4,550	10,200	17,900	0.086
15	RV 20/15.40-10	10	40	18	22.00	0.5	7,950	4,950	14,500	26,500	0.110
12	RV 201/12-20	20	41	20	28.00	0.3	8,180	5,100	17,200	31,500	0.130
15	RV 202/15.41-20	20	41	20	28.00	0.5	8,180	5,100	17,200	31,500	0.120
17	RV 203/17-20	20	58	25	35.00	0.5	16,580	9,200	47,000	86,000	0.325
20	RV 204/20.57-30	30	57	22	41.00	0.6	16,910	9,200	47,000	86,000	0.290
20	RV 204/20.58-30	30	58	25	41.00	0.6	16,790	9,200	40,000	72,000	0.310

Remark: * The unit contamination protection is provided by side shields 2Z.

Technical supplement

	Cages	Precision	Grease
Steel -	Nil		
Polymid -	Nil	Normal (ISO)	Nil
Brass -	Nil		

Remark: If you have more inquiry of technical, please inquire
NIKO web-site: [Http://www.nipponkodobearings.com](http://www.nipponkodobearings.com)

TRACK ROLLER BEARINGS DOUBLE ROW
 SERIES **RM..2Z; RM..2RS**

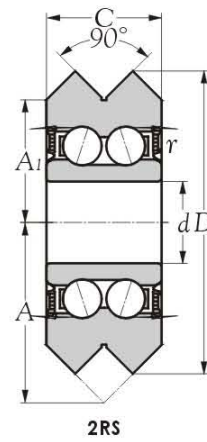
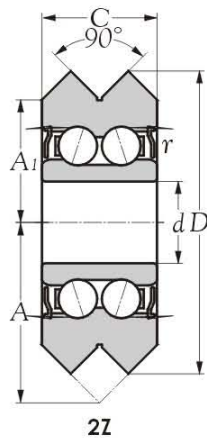

Boundary dimensions <i>d</i> mm	Bearing number		Boundary dimensions					Basic load ratings		Limiting speeds		Mass kg. (approx.)
			<i>D</i>	<i>A</i>	<i>C</i>	<i>A</i> ₁	<i>r</i> _s	<i>C</i> dynamic	<i>C</i> ₀ static	grease rpm	oil rpm	
4.763	RM 1 2Z	RM 1 2RS	19.56	11.86	7.87	7.93	0.3	1,650	1,140	4,150	7,500	0.012
9.525	RM 2 2Z	RM 2 2RS	30.73	18.24	11.10	12.70	0.3	8,260	2,650	6,500	11,700	0.040
11.999	RM 3 2Z	RM 3 2RS	45.72	26.98	15.88	19.05	0.6	5,530	5,200	31,000	55,000	0.136
15.001	RM 4 2Z	RM 4 2RS	59.94	34.93	19.05	25.40	1.0	16,250	9,200	39,500	72,000	0.285



Technical supplement

Cages	Precision	Grease
Steel - Nil		
Polymid - Nil	Normal (ISO)	Nil
Brass - Nil		

Remark: If you have more inquiry of technical, please inquire
 NIKO web-site: [Http://www.nipponkodobearings.com](http://www.nipponkodobearings.com)

TRACK ROLLER BEARINGS DOUBLE ROW
SERIES RV..C; RV..E

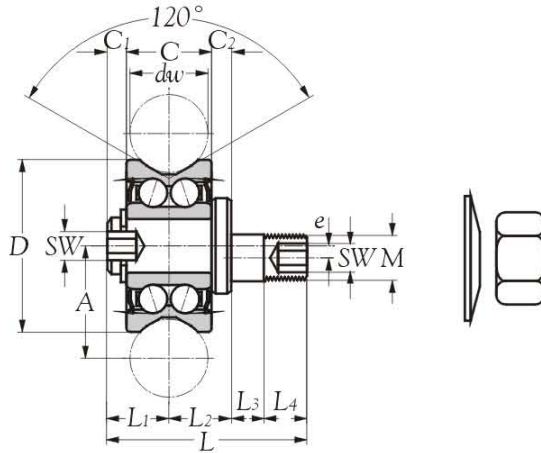

Boundary dimensions <i>dw</i> mm	Bearing number		Boundary dimensions													Basic load ratings		Limiting speeds		Mass kg. (approx.)
	concentric	eccentric	D	C	A	L	L ₁	L ₂	L ₃	L ₄	C ₁	C ₂	e	SW	M	dynamic	static	rpm		
	mm													C	C ₀	grease	oil			
10	RV 22 C	RV 22 E	22	11	14.5	26	8.5	8	4	5.5	3	3.0	1.5	3	M6	2,450	1,620	2,350	4,150	0.028
10	RV 30 C	RV 30 E	30	14	18.1	33	9.5	9	6	8.0	2	2.5	1.5	4	M8	4,490	2,700	11,000	19,800	0.069
10	RV 38 C	RV 38 E	38	17	22.3	42	11.0	11	8	12.0	3	2.5	2.0	5	M10	7,290	4,550	10,200	17,900	0.145
20	RV 41 C	RV 41 E	41	20	28.0	47	15.0	13	6	13.0	3	5.0	2.0	6	M12	8,180	5,100	17,200	31,500	0.190
20	RV 58 C	RV 58 E	58	25	35.0	59	17.0	19	11	13.0	6	4.0	2.5	6	M16	16,580	9,200	47,000	86,000	0.460

Remark: * Track rollers with integral studs are supplied with split washer and nut.
 * The unit contamination protection is provided by side shields 2Z.

Technical supplement

	Cages	Precision	Grease
Steel -	Nil		
Polymid -	Nil	Normal (ISO)	Nil
Brass -	Nil		

Remark: If you have more inquiry of technical, please inquire
 NIKO web-site: [Http://www.nipponkodobearings.com](http://www.nipponkodobearings.com)

TRACKROLLERBEARINGS DOUBLEROW
SERIES RPC; RPE

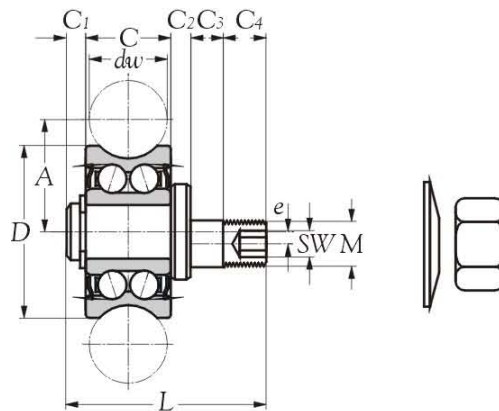

Boundary dimensions <i>dw</i> mm	Bearing number		Boundary dimensions											Basic load ratings		Limiting speeds		Mass kg. (approx.)
	concentric	eccentric	D	C	A	L	C ₁	C ₂	C ₃	C ₄	e	SW	M	dynamic N	static N	rpm		
	mm											C	C ₀	grease	oil			
6	RPC 17	RPE 17	17	7.0	10.50	23	1.5	1.5	5	5.5	0.50	2.5	M5	1,250	850	1,250	1,700	0.015
6	RPC 24	RPE 24	24	11.0	14.00	29	3.0	2.0	6	7.0	0.50	4.0	M8	3,500	2,200	1,250	4,350	0.042
10	RPC 35	RPE 35	35	15.9	20.65	44	3.2	2.0	10	13.0	0.75	5.0	M10	8,100	8,100	4,900	9,700	0.120

Remark: * Track rollers with integral studs are supplied with split washer and nut.



Technical supplement

	Cages	Precision	Grease
Steel -	Nil		
Polymid -	Nil	Normal (ISO)	Nil
Brass -	Nil		

Remark: If you have more inquiry of technical, please inquire
 NIKO web-site: [Http://www.nipponkodobearings.com](http://www.nipponkodobearings.com)

TRACK ROLLER BEARINGS DOUBLE ROW
SERIES RA..A

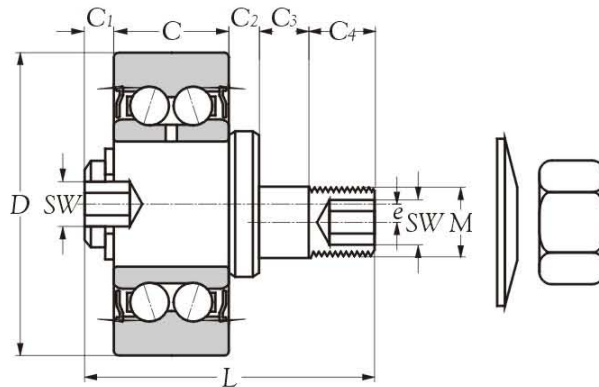

Bearing number	Boundary dimensions										Basic load ratings		Limiting speeds		Mass kg. (approx.)
	D	C	L	C ₁	C ₂	C ₃	C ₄	e	SW	M	C	C ₀	grease	oil	
mm											N		rpm		
RA 35 A	35	15.9	42	2.1	5	6.0	13	1.0	5	M 12	8,100	4,900	4,900	9,700	0.150
RA 52 A	52	22.2	57	3.3	8	9.5	14	1.5	6	M 16	16,000	9,100	11,500	15,800	0.345

Remark: * Track rollers with integral studs are supplied with split washer and nut.
 * The unit contamination protection is provided by side shields 2Z.



Technical supplement

Cages	Precision	Grease
Steel - Nil	Normal (ISO)	Nil
Polymid - Nil		
Brass - Nil		

Remark: If you have more inquiry of technical, please inquire
 NIKO web-site: [Http://www.nipponkodobearings.com](http://www.nipponkodobearings.com)

NIKO®

NIPPON KODO
AUTOMATION TECHNOLOGY

NIPPON KODO CO., LTD.
OSAKA-JAPAN



Brand Promise!



LINEAR MOTION 2012



FAIT GROUP SPA

VIA SCARPETTINI, 367-369
59013 OSTE MONTEMURLO (PO)
ITALY
TEL: +39 0574 68121
FAX: +39 0574 681262
E-MAIL: INFO@FAITGROUP.IT
WWW.FAITGROUP.IT

**NIPPON KODO AUTOMATION
TECHNOLOGY CO. LTD.**

ROOM 205, GRANDEUR IMAZATO BLDG.
NO. 1-4, 4-CHOME, IMAZATO,
NAGAKAKYO-CITY 617-0814, KYOTO, JAPAN
TEL: 81-75-959-0221
FAX: 81-75-959-0222
E-MAIL: NIKO@NIPPONKODOJAPAN.COM
WWW.NIPPONKODOBEARINGS.CO.JP