

NIKO[®]

NIPPON KODO
AUTOMATION TECHNOLOGY



BEARING













UNITS



BEARING UNITS



TECHNICAL INFORMATION		PAGES FOR REFER
		6 ~ 34
1.	CHARACTERISTICS	6
2.	DESIGN FEATURES	6 ~ 9
3.	TOLERANCE	9 ~ 12
4.	BASIC LOAD RATING AND LIFE	12 ~ 17
5.	LOADS	17 ~ 21
6.	BEARING INTERNAL CLEARANCE	21 ~ 23
7.	LUBRICATION	24 ~ 26
8.	SHAFT DESIGNS	26 ~ 28
9.	HANDLING OF THE BEARINGS UNIT	29 ~ 34

DIMENSION TABLE		PAGES FOR REFER
		36 ~ 51
	PILLOW BLOCKS CAST HOUSINGS (SET SCREW TYPE)	36 ~ 37
	UCP 200	
	FLANGED UNITS CAST HOUSINGS (SET SCREW TYPE)	38 ~ 39
	UCF 200	
	FLANGED UNITS CAST HOUSINGS (SET SCREW TYPE)	40 ~ 41
	UCFL 200	
	FLANGED CARTRIDGE UNITS CAST HOUSINGS (SET SCREW TYPE)	42 ~ 43
	UCFC 200	
	TAKE-UP UNITS CAST HOUSINGS (SET SCREW TYPE)	44 ~ 45
	UCT 200	
	PILLOW BLOCKS CAST HOUSINGS (SET SCREW TYPE)	46 ~ 47
	UCUP 200	
	BALL BEARINGS (SET SCREW TYPE)	48
	UC 200	
	BALL BEARINGS (ECCENTRIC LOCKING COLLAR TYPE)	49
	AEL 200	
	BALL BEARINGS (SET SCREW TYPE)	50
	AS 200	
	BALL BEARINGS (ADAPTER TYPE)	51
	UK 200	



TECHNICAL INFORMATION

1. Characteristics

The **NIKO** bearing unit is a combination of a radial ball bearing, seal, and a housing of high-grade cast iron or pressed steel, which comes in various shapes.

The outer surface of the bearing and the internal surface of the housing are spherical, so that the unit is self-aligning.

The inside construction of the ball bearing for the unit is such that steel balls and retainers of the same type as in series 62 and 63 of the **NIKO** deep groove ball bearing are used. A duplex seal consisting of a combination of an oil-proof synthetic rubber seal and a slinger, unique to **NIKO**, is provided on both sides.

Depending on the type, the following methods of fitting to the shaft are employed:

- (1) The inner ring is fastened onto the shaft in two places by set screws.
- (2) The inner ring has a tapered bore and is fitted to the shaft by means of an adapter.
- (3) In the eccentric locking collar system the inner ring is fastened to the shaft by means of eccentric grooves provided at the side of the inner ring and on the collar.

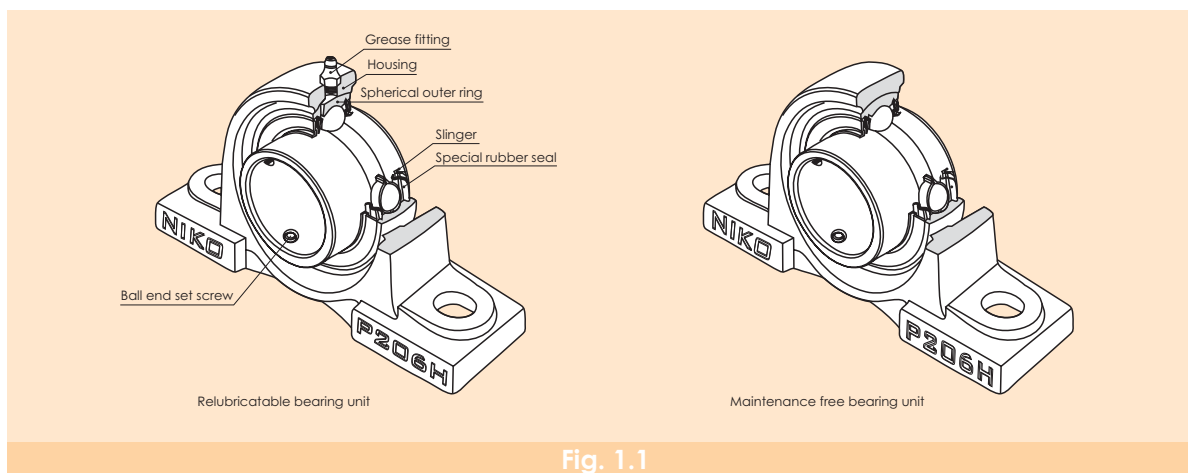

2. Design features

2.1 Maintenance free type

The **NIKO** Maintenance free bearing unit contains a high-grade lithium-based grease, good for use over a long period, which is ideally suited to sealed-type bearings. Also provided is an excellent sealing device, unique to **NIKO**, which prevents any leakage of grease or penetration of dust and water from outside.

It is designed so that the rotation of the shaft causes the sealed-in grease to circulate through the inside space, effectively providing maximum lubrication. The lubrication effect is maintained over a long period with no need for replenishment of grease.

To summarize the advantages of the **NIKO** maintenance free bearing unit:

- (1) As an adequate amount of good quality grease is sealed in at the time of manufacture, there is no need for replenishment. This means savings in terms of time and maintenance costs.
- (2) Since there is no need for any regreasing facilities, such as piping, a more compact design is possible.

(3) The sealed-in design eliminates the possibility of grease leakage, which could lead to stained products.

2.2 Relubricatable type

The **NIKO** relubricatable type bearing unit has an advantage over other similar units bearing so designed as to permit regreasing even in the case of misalignment of 2° to the right or left. The hole through which the grease fitting is mounted usually causes structural weakening of the housing.

However, as a result of extensive testing, in the **NIKO** bearing unit the hole is positioned so as to minimize this adverse effect. In addition, the regreasing groove has been designed to minimize weakening of the housing.

While the **NIKO** maintenance free type bearing unit is satisfactory for use under normal operating conditions in-doors, in the following circumstances it is necessary to use the relubricatable type bearing unit:

- (1) Cases where the temperature of the bearing rises above 100°C, 212°F:
 - * -Normal temperature of up to 200°C, 392°F heat-resistant bearing units.
- (2) Cases where there is excessive dust, but space does not permit using a bearing unit with a cover.
- (3) Cases where the bearing unit is constantly exposed to splashes of water or any other liquid, but space does not permit using a bearing unit with a cover.
- (4) Cases in which the humidity is very high, and the machine in which the bearing unit is used to run only intermittently.
- (5) Cases involving a heavy load of which the Cr/Pr value is about 10 or below, and the speed is 10 rpm or below, or the movement is oscillatory.
- (6) Cases where the number of revolutions is relatively high and the noise problem has to be considered; for example, when the bearing is used with the fan of an air conditioner.

2.3 Special sealing feature

2.3.1 Standard bearing units

The sealing device of the ball bearing for the **NIKO** Bearing unit is a Combination of a heat-resistant and oil-proof synthetic rubber seal and a slinger of an exclusive **NIKO** design.

The seal, which is fixed in the outer ring, is steel-reinforced, and its lip, in contact with the inner ring, is designed to minimize frictional torque.

The slinger is fixed to the inner ring of the bearing with which it rotates. There is a small clearance between its periphery and the outer ring.

There are triangular protrusions on the outside face of the slinger and, as the bearing rotates, these protrusions on the slinger create a flow of air outward from the bearing. In this way, the slinger acts as a fan which keeps dust and water away from the bearing.

These two types of seals on both sides of the bearing prevent grease leakage, and foreign matter is prevented from entering the bearing from outside.

2.3.2 Bearing units with covers

The **NIKO** bearing unit with a cover consists of a standard bearing unit and an outside covering for extra protection against dust. Special consideration has been given to its design with respect to dust-proofing.

Sealing devices are provided in both the bearing and the housing, so that units of this type operate satisfactorily even in such adverse environments as flour mills, steel mills, foundries, galvanizing plants and chemical plants, where excessive dust is produced and/ or liquids are

used. They are also eminently suitable for outdoor environments where dust and rain are inevitable, and in heavy industrial machinery such as construction and transportation equipment.

The rubber seal of the cover contacts with the shaft by its two lips, as shown in Fig.2.2 and 2.3. By filling the groove between the two lips with grease, an excellent sealing effect is obtained and, at the same time, the contacting portions of the lips are lubricated. Furthermore, the groove is so designed that when the shaft is inclined the rubber seal can move in the radial direction.

When bearing units are exposed to splashes of water rather than to dust, a drain hole (5 to 8 mm, 0.2 to 0.3 inches in diameter) is provided at the bottom of the cover, and grease should be applied to the side of the bearing itself instead of into the cover.

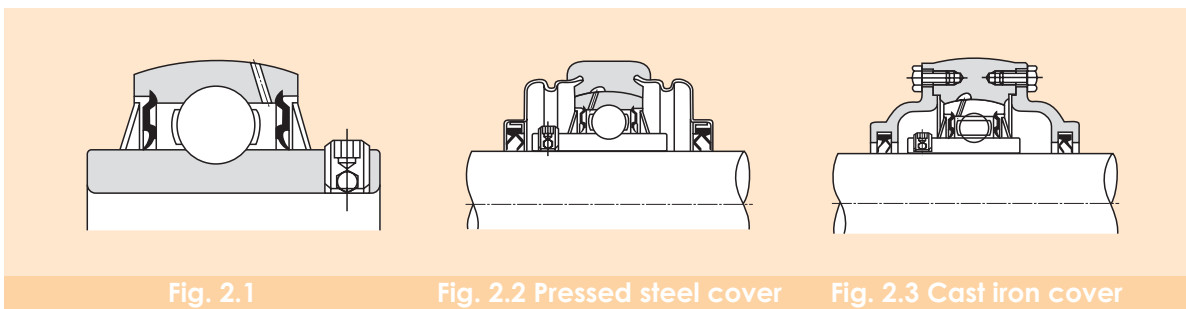

Fig. 2.1

Fig. 2.2 Pressed steel cover

Fig. 2.3 Cast iron cover

2.4 Secure fitting

Fastening the bearing to the shaft is effected by tightening the ball-end set screw, situated on the inner ring. This is a unique **NIKO** feature which prevents loosening, even if the bearing is subjected to intense vibrations and shocks.

2.5 Self-aligning

With the **NIKO** bearing unit, the outer surface of the ball bearing and the inner surface of the housing are spherical, thus alignment of the assembly is automatic. Any misalignment of axis that may arise from poor workmanship on the shaft or errors in fitting will be automatically adjusted.

2.6 Higher rated load capacity

The bearing used in the unit is of the same internal construction as those in **NIKO** bearing series 62 and 63, and is capable of accommodating axial load as well as radial load, or composite load. The rated load capacity of this bearing is considerably higher than that of the corresponding self-aligning ball bearings used for standard plumber blocks.

2.7 Light weight yet strong housing

Housings for **NIKO** bearing units come in various shapes. They consist of either high-grade cast iron, one-piece Casting, or of precision finished pressed steel, the latter being lighter in weight. In either case, they are practically designed to combine lightness with maximum strength.

2.8 Easy mounting

The **NIKO** bearing unit is an integrated unit consisting of a bearing and a housing.

As the bearing is prelubricated at manufacture with the correct amount of high-grade lithium base, it can be mounted on the shaft just as it is. It is sufficient to carry out a short test run after mounting.

2.9 Accurate fitting of the housing

In order to simplify the fitting of the pillow block and flange type bearing units, the housings are provided with a seat for a dowel pin, which may be utilized as needed.

2.10 Bearing replaceability

The bearing used in the **NIKO** bearing unit is replaceable. In the event of bearing failure, a new bearing can be fitted to the existing housing.

3. Tolerance

The tolerances of the **NIKO** bearing units are in accordance with the following JIS specifications:

3.1 Tolerances of ball bearings for the unit

Tolerances of ball bearings used in the unit are shown in the following tables, 3.1 to 3.3.

Table 3.1 Cylindrical bore (UC, AS, AEL)

(Unit : μm)

Nominal bore diameter		Cylindrical bore			width		Radial runout
d		Bore diameter		V_{dp}	$\Delta B_s, \Delta C_s$		K_{ia}
mm		Deviations		Variations	Deviations (reference)		(reference)
over	incl.	high	low	max.	high	low	max.
10.00	18.00	+15	0	10	0	-120	15
18.00	31.75	+18	0	12	0	-120	18
31.75	50.80	+21	0	14	0	-120	20
50.80	80.00	+24	0	16	0	-150	25
80.00	120.00	+28	0	19	0	-200	30

Note: Symbols Δd_{mp} : Mean bore diameter deviation
 V_{dp} : Bore diameter variation
 ΔB_s : Inner ring width deviation
 ΔC_s : Outer ring width deviation

Table 3.2 Outer ring

(Unit : μm)

Nominal outside diameter		Mean outside diameter deviation		Radial runout
D		ΔD_m		K_{ea}
mm				(reference)
over	incl.	high	low	max.
18	30	0	-9	15
30	50	0	-11	20
50	80	0	-13	25
80	120	0	-15	35
120	150	0	-18	40
150	180	0	-25	45

Note: 1) The low deviation of outside diameter D_m does not apply within the distance of 1/4 the width of the outer ring from the side.

Table 3.3 Eccentric locking collar

(Unit : mm)

Nominal bore diameter d mm		Bore diameter Δds		Small bore diameter of eccentric surface deviation $\Delta d2s$		Eccentricity deviation ΔHs		Collar width deviation $\Delta B2s$		Collar eccentric surface width deviation $\Delta A1s$	
over	incl.	High	low	High	low	High	low	High	low	High	low
10.000	36.512	0.25	+0.025	+0.3	0	+0.1	-0.1	+0.27	-0.27	0	-0.18
36.512	55.562	0.30	+0.025	+0.4	0	+0.1	-0.1	+0.33	-0.33	0	-0.18

3.4 Tolerances of housings

(Unit : μm)

Nominal spherical bore diameter Da mm		Da Deviations ΔDa Tolerance class H7	
over	incl.	High	low
30	50	+25	0
50	80	+30	0
80	120	+35	0
120	180	+40	0

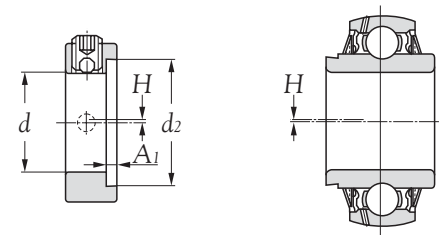

Eccentric locking collar

Eccentric locking collar type

Note: 1) Symbols ΔDa_m : Mean spherical bore diameter deviation.
 2) Dimensional tolerances for spherical bore diameter of housing are classified as H7 for clearance fit, and J7 for intermediate fit.

Table 3.5 Pillow Block housings (P, UP) (Unit : mm)

Housing numbers	H Deviations ΔHs
P 203	-
P 204	UP 204
P 205	UP 205
P 206	UP 206
P 207	UP 207
P 208	UP 208
P 209	UP 209
P 210	UP 210
P 211	-
P 212	-
P 213	-
P 214	-
P 215	-
P 216	-
P 217	-
P 218	-

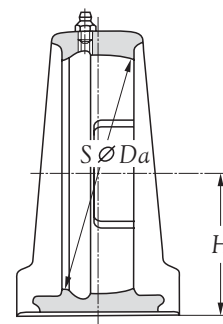

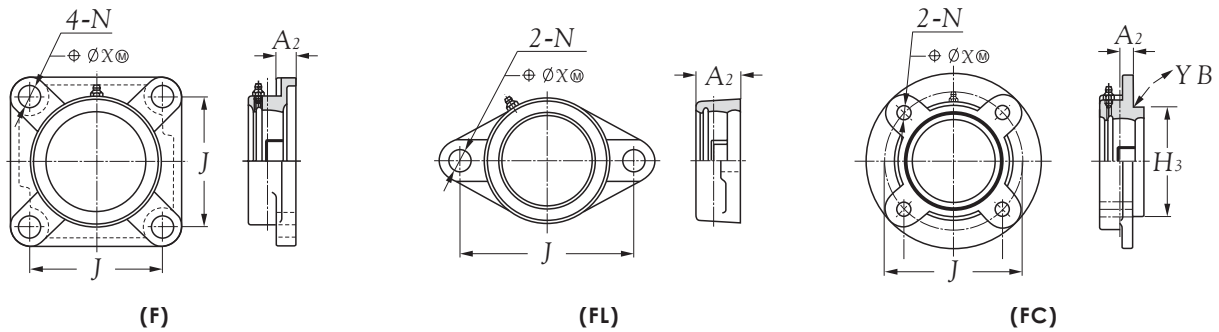

Table 3.6 (1) Flange unit housings (F, FC, FL)

(Unit : mm)

Housing numbers	location tolerance of bolt hole	A ₂ Deviations ΔA_{2s}	H ₃ Deviations		Radial runout of spigot joint Y			
			FC 2 high	low				
F 204 FL 204 FC 204	0.7	± 0.5	0	-0.0460	0.2			
F 205 FL 205 FC 205								
F 206 FL 206 FC 206								
F 207 FL 207 FC 207								
F 208 FL 208 FC 208								
F 209 FL 209 FC 209								
F 210 FL 210 FC 210	1.0	± 0.8	0	-0.0540	0.3			
F 211 FL 211 FC 211								
F 212 FL 212 FC 212								
F 213 FL 213 FC 213								
F 214 FL 214 FC 214								
F 215 FL 215 FC 215								
F 216 FL 216 FC 216								
F 217 FL 217 FC 217								
F 218 FL 218 FC 218								
						0	-0.0720	

Note: 1) J is the bolt hole's center line dimension, and P,C,D. A₂ is distance between the center line of spherical bore diameter of the housing and mounting surfaces, and H₃ is outside diameter of the spigot joint.

2) Radial runout of spigot joint is applied for flange units with spigot joints.

Table 3.6(2) Flange unit housings (diameter of bolt hole)

(Unit : mm)

Housing type	Nominal bore diameter N		N Deviations ΔN_s
	mm		
	over	incl.	mm
F, FL, FC	-	30	± 0.2
	30	40	± 0.3

Table 3.7 Take-up unit housings (T)

(Unit : m m)

Housing type	A _I Deviators ΔA _I s	H _I Deviators ΔH _I s		Parallelism of guide
		high	low	
T 204	±0.2	0	-0.5	0.5
T 205				
T 206				
T 207				
T 208				
T 209				
T 210				
T 211				
T 212				
T 213				
T 214	±0.3	0	-0.8	0.6
T 215				
T 216				
T 217				

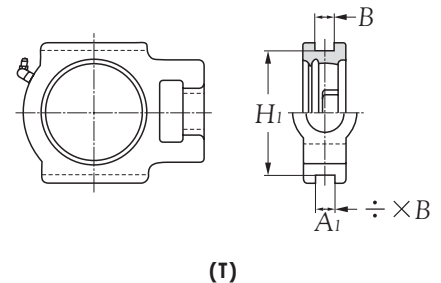

- Note: 1) A_I is the width of guide rail grooves.
 2) H_I is the maximum span of guide rail grooves.
 3) This table can be applied for bearing units with dust covers.

4. Basic Load Rating and Life

4.1 Bearing life

Even in bearings operating under normal conditions, the surfaces of the raceway and rolling elements are constantly being subjected to repeated compressive stresses which cause flaking of these surfaces to occur. This flaking is due to material fatigue and will eventually cause the bearings to fail. The effective life of a bearing is usually defined in terms of the total number of revolutions a bearing can undergo before flaking of either the raceway surface or the rolling element surfaces occurs.

Other causes of bearing failure are often attributed to problems such as seizing, abrasions, cracking, chipping, gnawing, rust, etc. However, these so called "causes" of bearing failure are usually themselves caused by improper installation, insufficient or inaccurate bearing selection. Since the above mentioned "causes" of bearing failure can be avoided by taking the proper precautions, and are not simply caused by material fatigue, they are considered separately from the flaking aspect.

4.2 Basic rated life and basic dynamic load rating

A group of seemingly identical bearings when subjected to identical load and operating conditions will exhibit a wide diversity in their durability.

This "life" disparity can be accounted for by the difference in the fatigue of the bearing material itself. This disparity is considered statistically when calculating bearing life, and the basic rated life is defined as follows.

The basic rated life is based on a 90% statistical model which is expressed as the total number of revolutions 90% of the bearings, in an identical group of bearings subjected to identical operating conditions, will attain or surpass before flaking due to material fatigue occurs. For bearings operating at fixed constant speeds, the basic rated life (90% reliability) is expressed in the total number of hours of operation.

The basic dynamic load rating is an expression of the load capacity of a bearing based on a constant load which the bearing can sustain for one million revolutions (the basic life rating). For radial bearings this rating applies to pure radial loads, and for thrust bearings it refers to pure axial loads. The basic dynamic load ratings given in the bearing tables of this catalog are for bearings constructed of **NIKO** standard bearing materials, using standard manufacturing techniques. Please consult **NIKO** for basic load ratings of bearings constructed of special materials or using special manufacturing techniques.

The relationship between the basic rated life, the basic dynamic load rating and the bearing load is given in formula (4.1).

$$L_{10} = \left(\frac{C_r}{P_r} \right)^3 \dots\dots\dots(4.1)$$

where,

- L_{10} : Basic rated life 10^6 revolutions
- C_r : Basic dynamic rated load, N, lbf
- P_r : Equivalent dynamic load, N, lbf

The basic rated life can also be expressed in terms of hours of operation (revolution), and is calculated as shown in formula (4.2).

$$L_{10h} = 500f_h^3 \dots\dots\dots(4.2)$$

$$f_h = f_h \frac{C_r}{P_r} \dots\dots\dots(4.3)$$

$$f_n = \left(\frac{33.3}{n} \right)^{1/3} \dots\dots\dots(4.4)$$

where,

- L_{10h} : Basic rated life, h
- f_h : Life factor
- f_n : Speed factor
- n : Rotational speed, r/min

Formula (4.2) can also be expressed as shown in formula (4.5).

$$L_{10h} = \frac{10^6}{60n} \left(\frac{C_r}{P_r} \right)^3 \dots\dots\dots(4.5)$$

The relation between rotational speed n and speed factor f_n as well as the relation between the basic rated life L_{10h} and the life factor f_h is shown in Fig. 4.1.

When several bearings are incorporated in machines or equipment as complete units, all the bearings in the unit are considered as a whole when computing bearing life (see formula 4.6). The total bearing life of the unit is a life rating based on the viable lifetime of the unit before even one of the bearings fails due to rolling contact fatigue.

$$L = \frac{1}{\left(\frac{1}{L_1^{1.1}} + \frac{1}{L_2^{1.1}} + \dots\dots + \frac{1}{L_n^{1.1}} \right)^{1/1.1}} \dots\dots\dots(4.6)$$

where,

- L : Total life of the whole bearing assembly h
- L_1, L_2, \dots, L_n : Rated life of bearings 1, 2, ..., n, h

In the case where load and the number of revolutions change at regulated intervals, after finding the rated life L_1, L_2, \dots, L_n under conditions of $n_1, P_1; n_2, P_2; \dots; n_n, P_n$; the built-life L_m can be given by the formula (4.7).

$$L_1 = \frac{10^6}{60n_1} \left(\frac{C_r}{P_1} \right)^3$$

$$L_2 = \frac{10^6}{60n_2} \left(\frac{C_r}{P_2} \right)^3$$

⋮

$$L_n = \frac{10^6}{60n_n} \left(\frac{C_r}{P_n} \right)^3$$

$$L_m = \left(\frac{\varnothing_1}{L_1} + \frac{\varnothing_2}{L_2} + \dots + \frac{\varnothing_n}{L_n} \right)^{-1} \dots\dots\dots(4.7)$$

where,

- L_1, L_2, \dots, L_n : Rated life under condition 1, 2, ..., n, h
- n_1, n_2, \dots, n_n : Number of revolutions under condition 1, 2, ..., n, r/min
- P_1, P_2, \dots, P_n : Equivalent load under condition 1, 2, ..., n, N, lbf
- $\varnothing_1, \varnothing_2, \dots, \varnothing_n$: Ratio of condition 1, 2, ..., n accounting for the total operating time
- L_m : Built-in life, h

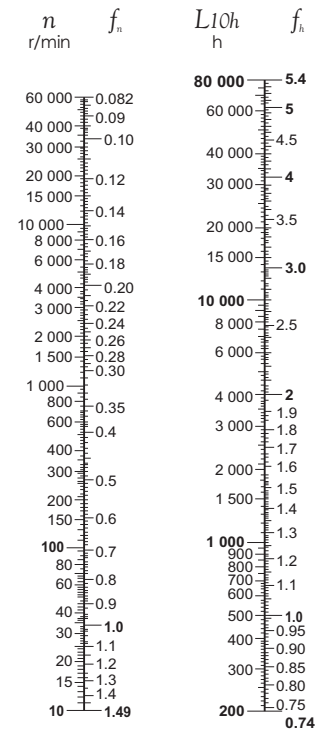

Fig. 4.1 Bearing life rating scale

Table 4.1 Rating life for applications

Service classification	Machine application	Life time Ln
Machines used occasionally	Door mechanisms, Garage shutter	500
Equipment for short period or intermittent service-interruption permissible	Household appliances, Electric hand tools, Agricultural machines, Lifting tackles in shops	4000~8000
Intermittent service machines-high reliability	Power-Station auxiliary equipment, Elevators, Conveyors, Deck cranes	8000~14000
Machines used for 8 hours a day, but not always in full operation	Ore wagon axles, Important gear units	14000~20000
Machines fully used for 8 hours	Dblowers, General machinery in shops, Continuous operation cranes	20000~30000
Machines continuously used for 24 hours a day	Compressors, Pumps	50000~60000
Machines continuously used for 24 hours a day with maximum reliability	Power-station equipment, Water-supply equipment for urban areas, Mine ventilators	100000~200000

4.3 Machine applications and requisite life

When selecting a bearing, it is essential that the requisite life of the bearing be established in relation to the operating conditions. The requisite life of the bearing is usually determined by the type of machine the bearing is to be used in, and duration of service and operational reliability requirements. A general guide to these requisite life criteria is shown in Table 4.1. When determining bearing size, the fatigue life of the bearing is an important factor; however, besides bearing life, the strength and rigidity of the shaft and housing must also be taken into consideration.

4.4 Adjusted life rating factor

The basic bearing life rating (90% reliability factor) can be calculated through the formulas mentioned earlier in Section 4.2. However, in some applications a bearing life factor of over 90% reliability may be required. To meet these requirements, bearing life can be lengthened by the use of specially improved bearing materials or special construction techniques. Moreover, according to elastohydrodynamic lubrication theory, it is clear that the bearing operating conditions (lubrication, temperature, speed, etc.) all exert an effect on bearing life. All these adjustment factors are taken into consideration when calculating bearing life, and using the life adjustment factor as prescribed in ISO 281, the adjusted bearing life can be arrived at.

$$L_{na} = a_1 a_2 a_3 \left(\frac{C}{P} \right)^3 \dots\dots\dots(4.8)$$

where,

- L_{na} : Adjusted life rating in millions of revolutions (10^6) (adjusted for reliability, material and operating conditions)
- a_1 : Reliability adjustment factor
- a_2 : Material adjustment factor
- a_3 : Operating condition adjustment factor

4.4.4 Life adjustment factor for reliability a_1

The values for the reliability adjustment factor a_1 (for a reliability factor higher than 90%) can be found in table 4.2.

Table 4.2 Reliability adjustment factor values a_1

Reliability %	L_n	Reliability factor a_1
90	L_{10}	1.00
95	L_5	0.62
96	L_4	0.53
97	L_3	0.44
98	L_2	0.33
99	L_1	0.21

4.4.2 Life adjustment factor for material a_2

The life of a bearing is affected by the material type and quality as well as the manufacturing process. In this regard, the life is adjusted by the use of an a_2 factor.

The basic dynamic load ratings listed in the catalogue are based on **NIKO**'s standard material and process, therefore, the adjustment factor $a_2 = 1$. When special materials or processes are used the adjustment factor a_2 can be larger than 1.

NIKO bearings can generally be used up to 120°C. If bearings are operated at a higher temperature, the bearing must be specially heat treated (stabilized) so that inadmissible dimensional change does not occur due to micro-structure change. This special heat treatment might cause the reduction of bearing life because of a hardness change.

4.4.3 Life adjustment factor a_3 for operating conditions

The operating conditions life adjustment factor a_3 is used to adjust for such conditions as lubrication, operating temperature, and other operation factors which have an effect on bearing life.

Generally speaking, when lubricating conditions are satisfactory, the a_3 factor has a value of one; and when lubricating conditions are exceptionally favorable, and all other operating conditions are normal, a_3 can have a value greater than one.

However, when lubricating conditions are particularly unfavorable and the oil film formation on the contact surfaces of the raceway and rolling elements is insufficient, the value of a_3 becomes less than one. This insufficient oil film formation can be caused, for example, by the lubricating oil viscosity being too low for the operating temperature (below $13\text{mm}^2/\text{s}$ for ball bearings); or by exceptionally low rotational speed ($n \text{ r/min} \times dp \text{ mm}$ less than 10 000). For bearings used under special operating conditions, please consult **NIKO**.

As the operating temperature of the bearing increases, the hardness of the bearing material decreases. Thus, the bearing life correspondingly decreases. The operating temperature adjustment values are shown in Fig. 4.2.

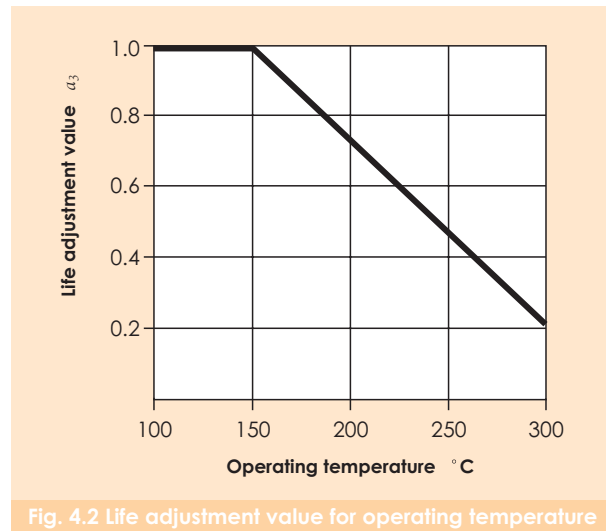

Fig. 4.2 Life adjustment value for operating temperature

4.5 Basic static load rating

When stationary rolling bearings are subjected to static loads, they suffer from partial permanent deformation of the contact surfaces at the contact point between the rolling elements and the raceway. The amount of deformity increases as the load increases, and if this increase in load exceeds certain limits, the subsequent smooth operation of the bearing is impaired.

It has been found through experience that a permanent deformity of 0.0001 times the diameter of the rolling element, occurring at the most heavily stressed contact point between the raceway and the rolling elements, can be tolerated without any impairment in running efficiency.

The basic rated static load refers to a fixed static load limit at which a specified amount of permanent deformation occurs. It applies to pure radial loads for radial bearings. The maximum applied load values for contact stress occurring at the rolling element and raceway contact points are given below.

For ball bearings (for bearing unit) : 4200 MPa

4.6 Allowable static equivalent load

Generally the static equivalent load which can be permitted (see section 5.3) is limited by the basic static rated load as stated in Section 4.5. However, depending on requirements regarding friction and smooth operation, these limits may be greater or lesser than the basic static rated load.

In the following formula (4.9) and Table 4.3 the safety factor S_o can be determined considering the maximum static equivalent load.

$$S_o = \frac{C_o}{P_{o \max}} \dots\dots\dots(4.9)$$

where,

S_o : Safety factor

C_o : Basic static rated load, N, lbf

$P_{o \max}$: Maximum static equivalent load, N, lbf

Table 4.3 Minmum safety factor values S_o

Operating conditions	Ball bearings
High rotational accuracy demand	2.0
Normal rotating accuracy demand (Universal application)	1.0
Slight rotational accuracy deterioration permitted (Low speed, heavy loading, etc.)	0.5

Note : 1) When vibration and/or shock loads are present, a load factor based on the shock load needs to be included in the $P_{a \max}$ value.

5. Loads

5.1 Load acting on the bearing

It is very rare that the load on a bearing can be obtained by a simple calculation. Loads applied to the bearing generally include the weight of the rotating element itself, the load produced by the working of the machine, and the load resulting from transmission of power by the belt and gearwheel. Such loads include the radial load, which works on the bearing at right angles to its axis, and the thrust load, which works on the bearing parallel to its axis. These can work either singly or in combination. In addition, the operation of a machine inevitably produces a varying degree of vibrations and shocks. To take this into account, the theoretical value of a load is multiplied by a safety factor that has been derived from past experience. This is known as the "load factor".

$$\text{Load acting on the bearing} = \text{Load factor } f_w \times \text{Calculated Load}$$

Table 5.1 below shows the generally accepted load factors f_w which correspond to the degree of shock to which the machine is subjected.

Table5.1 Load factors f_w

Load conditions	f_w	Examples
Little or on shock	1 to 1.2	Machines tools, electric machines, etc
Some degree of shock; machines with reciprocating parts	1.2 to 1.5	Vehicles, driving mechanism, metal-working machinery, steel-making machines, paper-making machinery, rubber mixing machines, hydraulic equipment, hoists, transportation machinery, power-transmission equipment, woodworking machines, printing machines, etc
violent shocks	1.5 to 3	Agricultural machines, vibrator screens, ball and tube mills, etc.

In the case of power transmission by belts, gear wheels, etc, load factors adopted are somewhat different from the above.

Factors used for power transmission by belts, gearwheels and chains, respectively, are given in the following sections.

5.1.1 Load applied to the bearing by power transmission

The force working on the shaft when power is transmitted by belts. Chains or gearwheels is obtained, in general, by the following formula:

$$T = 9550 \frac{H}{n}, 84500 \frac{H}{n} \dots\dots\dots(5.1)$$

$$K_t = \frac{T}{r} \dots\dots\dots(5.2)$$

where,

- T : Torque, N · m, lbf · inch
- H : Transmission power, kW
- n : Number of revolutions, r/min
- K_t : Transmission force (effective transmission force of belt or chain; tangential force of gearwheel), N, lbf
- r : effective radius of belt pulley, sprocket wheel or gearwheel, m, inch

Accordingly, the load actually applied to the shaft by the transmission force can be obtained by the following formula:

$$\text{Actual load} = \text{Factor} \times K_t \dots\dots\dots(5.3)$$

Different factors are adopted according to the transmission system in use. These will be dealt with in the following paragraphs.

Belt transmission

When power is transmitted by belt, the effective transmission force working on the belt pulley is calculated by formula (5.2). The term "effective transmission force of the belt" refers to the difference in tension between the tensioned side and the loose side of the belt. Therefore, to obtain the load actually acting on the shaft through the medium of the belt pulley, it is necessary to multiply the effective transmission force by a factor which takes into account the type of belt and the initial tension. This is known as the "belt factor".

Table 5.2 Belt factor *f_b*

Belt type	<i>f_b</i>
V-belt	1.5 to 2.0
Timing belt	1.1 to 1.3
Flat belt (with tension pulley)	2.5 to 3.0
Flat belt (with tension pulley)	3.0 to 4.0

Note: In cases where the distance between shafts is short the revolution speed is low, or where operating conditions severe, the higher *f_b* values should be adopted.

Gear transmission

In the case of gear transmissions, the theoretical gear load can be calculated from the transmission force and the type of gear. With spur gears, only a radial load is involved; whereas, with helical gears and bevel gears, an additional axial load is present.

The simplest case is that of spur gears. In this instance, the tangential force *K_t* is obtained from the formula (5.2) and the radial force *K_s* can be obtained from the following formula:

$$K_s = K_t \cdot \text{Tan } \alpha \dots\dots\dots(5.4)$$

where,

α is the pressure angle of the gear.

Accordingly, the theoretical composite force, K_r , working on the gear is obtained from the following formula:

$$K_r = \sqrt{K_t^2 \cdot K_s^2} = K_t \cdot \sec \alpha \dots\dots\dots(5.5)$$

Therefore, to obtain the radial load actually working on the shaft, the theoretical composite force, as above, multiplied by a factor in which the accuracy and the degree of precision of the gear is taken into account. This is called the "gear factor" and is represented by the symbol f_z . In Table 5.3 is below, f_z values for spur wheels are given.

The gear factor is essentially almost the same as the previously described load factor, f_w . In some cases, however, vibrations and shocks are produced also by the machine of which the gear is a part. here it is necessary to calculate the actual load working on the gear by further multiplying the gear load, as obtained above, by the load factor shown in Table 5.1, according to the degree of shock.

Table 5.3 Gear factors f_z

Gear	f_z
Precision gears (tolerance 0.02mm max., For both pitch and shape)	1.05 to 1.1
Gears finished by ordinary machining work (tolerance 0.02 to 0.1mm, for both pitch and shape)	1.10 to 1.3

Chain transmission

When power is transmitted by chain, the effective transmission force working on the sprocket wheel is calculated by formula (5.2). To obtain the load actually working, the effective transmission force must be multiplied by the "chain factor", 1.2 to 1.5.

5.1.2 Distribution of the radial load

The load acting on the shaft is distributed to the bearings which support the shaft. In Fig.5.1, the load is applied to the shaft between two bearings; In Fig.5.2 the load is applied to the shaft outside the two bearings. In practice, however, most cases are combinations of Fig.5.1 and 5.2, and the load is usually a composite load, that is to say, a combination of radial and axial loads. Therefore they are calculated by the methods described in the following sections.

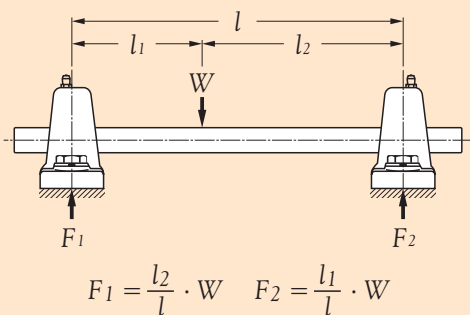

Fig. 5.1

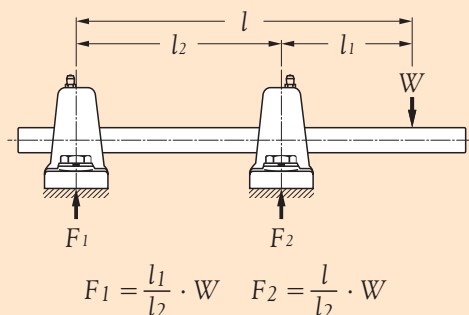

Fig. 5.2

5.2 Equivalent dynamic radial load

For ball bearings used in the **NIKO** unit, the basic rated dynamic loads C_r mentioned in the table of dimensions are applicable only when the load is purely radial. In practice, however, bearings are usually subjected to a composite load. As the table of dimensions is not directly applicable here, it is necessary to convert the values of the radial and axial loads into a single radial load value that would have an effect on the life of bearing equivalent to that of the actual load applied. This is known as the "equivalent dynamic radial load", and from this the life of the ball bearings for the unit is calculated. The equivalent dynamic radial load is calculated by the following formula:

$$P_r = X \cdot F_r + Y \cdot F_a \dots\dots\dots(5.6)$$

where,

- P_r : equivalent dynamic radial load N, lbf
- F_r : radial load N, lbf
- F_a : axial load N, lbf
- X : radial factor
- Y : axial factor

Values of X and Y are shown in Table 5.4 below.

With ball bearings for the unit, when only radial load is involved, or when $F_a/F_r \leq e$ (e is value which is determined, by the size of an individual bearing and the load acting thereon), the values of X and Y will be 1 and 0 respectively, resulting in the following equation:

$$P_r = F_r \dots\dots\dots(5.7)$$

Table 5.4 Values of X and Y applying when $\frac{F_a}{F_r} > e$

$\frac{F_a}{C_{or}}$	e	X	Y
0.01	0.18	0.56	2.46
0.02	0.20		2.14
0.04	0.24		1.83
0.07	0.27		1.61
0.10	0.29		1.48
0.15	0.32		1.35
0.20	0.35		1.25
0.30	0.38		1.13
0.40	0.41		1.05
0.50	0.44		1.00

Note : C_{or} is the basic rated static load. (See the table of dimensions.) When the value of $\frac{F_a}{C_{or}}$ or $\frac{F_a}{F_r}$ is not in conformity with those given in Table 5.4 above, find the value by interpolation.

5.3 Equivalent static radial load

In the case of a bearing which is stationary, rotates at a low speed of about 10rpm, or makes slight oscillating movements, it is necessary to take into account the equivalent static radial load, which is the counterpart of the equivalent dynamic radial load of a rotating bearing. In this case, the following formula is used.

$$P_{or} = X_o \cdot F_r + Y_o \cdot F_a \dots\dots\dots(5.8)$$

where,

- P_{or} : equivalent static radial load N, lbf
- F_r : radial load N, lbf
- F_a : axial load N, lbf
- X_o : static radial factor
- Y_o : static axial factor

With the ball bearings for the **NIKO** unit, the values of X_o and Y_o are $X_o = 0.6$; $Y_o = 0.5$.
 However when only radial load is involved, or when $F_a/F_r \leq e$, the following values in used:

$$X_o = 1 \qquad Y_o = 0$$

Accordingly, the following equation holds.

$$P_{or} = F_r \dots\dots\dots(5.9)$$

6. Bearing Internal Clearance

6.1 Bearing internal clearance

Bearing internal clearance (initial clearance) is the amount of internal clearance a bearing has before being installed on a shaft or in a housing.

As shown in Fig.6.1, when either the inner ring or the outer ring is fixed and the other ring is free to move, displacement can take place in either an axial or radial direction. This amount of displacement (radially or axially) is termed the internal clearance and, depending on the direction, is called the radial internal clearance or the axial internal clearance.

When the internal clearance of a bearing is measured, a slight measurement load is applied to the raceway so the internal clearance may be measured accurately. However, at this time, a slight amount of elastic deformation of the bearing occurs under the measurement load, and the clearance measurement value (measured clearance) is slightly larger than the true clearance. This discrepancy between the true bearing clearance and the increased amount due to the elastic deformation must be compensated for. These compensation values are given in Table 6.1.

The internal clearance values for each bearing class are shown in Tables 6.3.

Table 6.1 Adjustment of radial internal clearance based on measured load (Unit : μm)

Nominal bore diameter d (mm)		Measuring Load (N)	Radial Clearance Increase				
over	incl.		C2	CN	C3	C4	C5
10	18	24.5	3~4	4	4	4	4
18	50	49.0	4~5	5	6	6	6
50	200	147.0	6~8	8	9	9	9

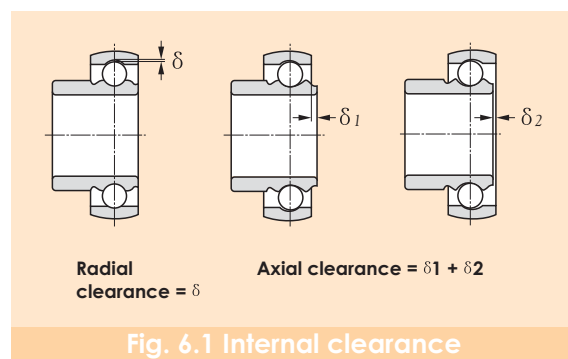

Fig. 6.1 Internal clearance

6.2 Internal clearance selection

The internal clearance of a bearing under operating conditions (effective clearance) is usually smaller than the same bearing's initial clearance before being installed and operated. This is due to several factors including bearing fit, the difference in temperature between the inner and outer rings, etc. As a bearing's operating clearance has an effect on bearing life, heat generation, vibration, noise, etc.; care must be taken in selecting the most suitable operating clearance.

Effective internal clearance:

The internal clearance differential between the initial clearance and the operating (effective) clearance (the amount of clearance reduction caused by interference fits, or clearance variation due to the temperature difference between the inner and outer rings) can be calculated by the following formula:

$$\delta_{eff} = \delta_o - (\delta_f + \delta_t) \dots\dots\dots(6.1)$$

where,

- δ_{eff} : Effective internal clearance, mm
- δ_o : Bearing internal clearance, mm
- δ_f : Reduced amount of clearance due to interference, mm
- δ_t : Reduced amount of clearance due to temperature differential of inner and outer rings, mm

Reduced clearance due to interference:

When bearings are installed with interference fits on shafts and in housings, the inner ring will expand and the outer ring will contract; thus reducing the bearing's internal clearance. The amount of expansion or contraction varies depending on the shape of the bearing, the shape of the shaft or housing, dimensions of the respective parts, and the type of materials used. The differential can range from approximately 70% to 90% of the effective interference.

$$\delta_f = (0.70 \sim 0.90) \cdot \Delta d_{eff} \dots\dots\dots(6.2)$$

where,

- δ_f : Reduced amount of clearance due to interference, mm
- Δd_{eff} : Effective interference, mm

Reduced internal clearance due to inner/outer ring temperature difference:

During operation, normally the outer ring will be from 5° to 10°C cooler than the inner ring or rotating parts. However, if the cooling effect of the housing is large, the shaft is connected to a heat source, or a heated substance is conducted through the hollow shaft; the temperature difference between the two rings can be even greater. The amount of internal clearance is thus further reduced by the differential expansion of the two rings.

$$\delta_l = \alpha \cdot \Delta T \cdot D_o \dots\dots\dots(6.3)$$

where,

- δ_l : Amount of reduced clearance due to heat differential, mm
- α : Bearing steel linear expansion coefficient $12.5 \times 10^{-6}/^{\circ}\text{C}$
- ΔT : Inner / outer ring temperature differential, °C
- D_o : Outer ring raceway diameter, mm

Outer ring raceway diameter, D_o , values can be approximated by using formula 6.4.
For ball bearings,

$$D_o = 0.20 (d + 4.0 D) \dots\dots\dots(6.4)$$

where,

d : Bearing bore diameter, mm

D : Bearing outside diameter, mm

6.3 Bearing internal clearance selection standards

Theoretically, in regard to bearing life, the optimum operating internal clearance for any bearing would be a slight negative clearance after the bearing had reached normal operating temperature.

Unfortunately, under actual operating conditions, maintaining such optimum tolerances is often difficult at best. Due to various fluctuating operating conditions this slight minus clearance can quickly become a large minus, greatly lowering the life of the bearing and causing excessive heat to be generated. Therefore, an initial internal clearance which will result in a slightly greater than negative internal operating clearance should be selected.

Under normal operating conditions (e.g. normal load, fit, speed, temperature, etc.), a standard internal clearance will give a very satisfactory operating clearance.

Table 6.2 lists non-standard clearance recommendations for various applications and operating conditions.

Table 6.2 Examples of applications where bearing clearances other than normal clearance are used

Operating conditions	Applications	Selected clearance
Shaft is heated and housing is cooled.	Conveyor of casting machine	C5
Shaft or inner ring is heated.	Annealing pit, Drying pit, Curing pit	C4
Allows for shaft deflection and fitting errors.	Disc harrows	C4
	Combines	C3
Tight-fitted for both inner and outer rings.	Large blowers	C3
To reduce noise and vibration when rotating	Multi-wing fan of air conditioners	C2

Table 6.3 Cylindrical bore bearings

(Unit : μm)

Nominal bore diameter		Radial internal clearance							
d (mm)		C2		CN		C3		C4	
over	incl.	min.	max.	min.	max.	min.	max.	min.	max.
10	18	0	9	3	18	11	25	18	33
18	24	0	10	5	20	13	28	20	36
24	30	1	11	5	20	13	28	23	41
30	40	1	11	6	20	15	33	28	46
40	50	1	11	6	23	18	36	30	51
50	65	1	15	8	28	23	43	38	61
65	80	1	15	10	30	25	51	46	71
80	100	1	18	12	36	30	58	53	84

Note : Heat-resistant bearings with suffix HT2 have C4 clearances.

7. Lubrication

As bearings in **NIKO** bearing units have sufficient high-grade grease sealed in at the time of manufacture, there is no need for replenishment while in use. The amount of grease necessary for lubrication is, in general, very small. With the **NIKO** Bearing units, the amount of grease occupies about a half to a third of the space inside the bearing.

7.1 Maximum permissible speed of rotation

The maximum speed possible while ensuring the safety and long life of ball bearings used in the unit is limited by their size, the circumferential speed at the point where the seal comes into contact, and the load acting on them.

To indicate the maximum speed permissible, it is customary to use the value of dn or dmn (d is the bore of the bearing; dm is the diameter of the pitch circle = $(I.d.+ O.D.) / 2$; n is the number of revolutions).

Problems connected with the lubrication of bearings are the generation of heat and seizures occurring at the sliding parts inside the bearing, in particular at the points where the ball is in contact with the retainer, inner and outer rings. The contact pressure at the points where friction occurs on the retainer is only slightly affected by the load acting on the bearing; the amount of heat generated there is approximately in proportion to the sliding velocity. Therefore, this sliding velocity serves as a yardstick to measure the limit of the rotating speed of the another large factor that has to be taken into account — the circumferential speed at the part where the seal is in contact.

The graph in Fig.7.1 indicates the maximum speed of rotation permissible, taking into account the aforementioned factors.

There are two common methods of locking the bearing unit onto the shaft — the set screw system and the eccentric collar system. However, in both of these systems high-speed operation will cause deformation of the inner ring, which may result in vibration of the bearing. For high-speed operation, therefore, it is recommended that an interference fit or a clearance fit with a near-zero clearance be used, with a shaft of the larger size as shown later in this manual in Fig. 8.1, Fig.8.6.

For standard bearing units with the contact type seal, the maximum speed permissible is $120000/d$. Where a higher speed is required, bearing units with the non-contact type seal, are advised. Please contact **NIKO** regarding the use of the latter type. Additionally, it is necessary that the surface on which the housing is mounted be finished to as a high a degree of accuracy as possible. A regularity of within $\pm 0.05\text{mm}$, ± 0.002 inch is required.

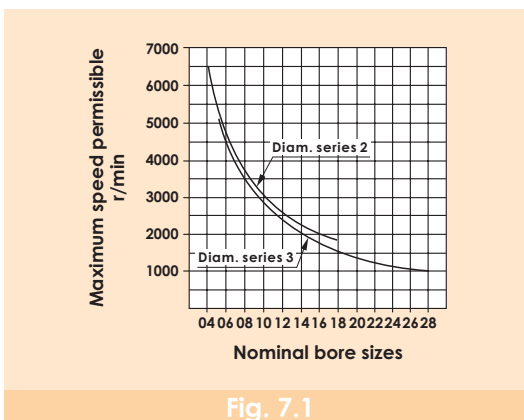

Fig. 7.1

7.2 Replenishment of grease

7.2.1 Sealed-in grease

with **NIKO** bearing units, no relubrication is the general rule. The standard self-lubricating type of bearing units contain high-grade lithium-based grease which, being suitable for long-term use, is ideal for sealed-type bearings, They also feature **NIKO**'s unique sealing device. Relubrication, therefore, is unnecessary under most operating conditions.

At high temperatures, or where there is exposure to water or excessive dust, the highest quality grease is essential. Therefore, **NIKO** uses its own specially selected brands which are shown in Table 7.1. It is necessary to use the same brand when replenishing grease.

Table 7.1 Brands of grease used in NIKO bearing units

Bearing units	Grease			Symbols	Operating temperature range
	Name of grease	Thickening agent	Base oil		
Standard	Alvania grease 3	Li soap	Mineral oil	D1	-15° to +100° C, (+5° to +212° F)
Heat-resistant	SH44M	Li soap	Silicone oil	HT2D1	Normal temp. To +200° C (392° F)
Cold-resistant	SH33L	Li soap	Silicone oil	CT1D1	-60° C, (-76° F) to normal temp.

7.2.2 Mixing of different kinds of grease

Whether or not different kinds of grease may be mixed usually depends on their thickeners. The commonly used criteria are shown in Table 7.2. Properties which are most susceptible to influences from mixing are viscosity, dropping point and penetration. Water and heat resisting properties as well as mechanical stability are also lowered. Therefore, when mixing in a grease which is different to that which is already in use, it is essential that the thickener (soap base) and the base oil be of the same group.

When relubricating **NIKO** bearing units, it is advisable to use the brands of grease shown in Table 7.1.

Table 7.2 Mixing properties of grease

Soap base	Ca	Na	Al	Ba	Li
Ca	○	△	△	X	△
Na	△	○	△	X	X
Al	△	△	○	X	X
Ba	X	X	X	○	X
Li	△	X	X	X	○

○ Mixing will not produce any appreciable change of properties.

△ Mixing may produce considerable variations of properties.

X Mixing will cause a drastic change of properties.

7.2.3 Relubrication frequency

Relubrication frequency varies with the kind and quality of grease used as well as the operating conditions. Therefore, it is difficult to establish a general rule, but under ordinary operating conditions, it is desirable that grease be replenished before one third (1/3) of its calculated life elapses. It is necessary, however, to take into consideration such factors as hardening of grease in the oil hole, making replenishment impossible; deterioration of grease while operation of the machine is suspended, and so forth.

In Table 7.3 below are shown standard relubrication frequencies. Irrespective of the calculated life of the grease, this list takes into consideration such factors as the rotational speed of the bearings, operating temperatures and environmental conditions, with a view to safety.

7.2.4 Re-greasing

The performance of a bearing is greatly influenced by the quantity of grease. In order to avoid over-filling, it is advisable to replenish the grease while the machine is in operation.

Continue to insert grease until a little oozes out from between the outer ring raceway and the periphery of the slinger, for optimum performance.

Table 7.3 Standard relubrication frequencies

Type of unit	Symbol	dn Value	Environmental conditions	Operating temp °C, °F	Relubrication frequency	
					Hours	Period
Standard	D1	40 000 and below	Ordinary	-15 to +80, +5 to +176	1550 to 3000	6 to 12 mo.
Standard	D1	70 000 and below	Ordinary	-15 to +80, +5 to +176	1000 to 2000	3 to 6 mo.
Standard	D1	70 000 and below	Ordinary	+80 to +100, +176 to +212	500 to 700	1 mo.
Heat-resistant	HT2D1	70 000 and below	Ordinary	+140 to +170, +284 to +338	300 to 700	1 mo.
Heat-resistant	HT2D1	70 000 and below	Ordinary	+170 to +200, +338 to +392	100	1 wk.
Cold-resistant	CT2D1	70 000 and below	Ordinary	-60 to +80, -76 to +176	1000 to 2000	3 to 6 mo.
Standard	D1	70 000 and below	Very dusty	-15 to +100, +5 to +212	100 to 500	1 wk. To 1 mo.
Standard	D1	70 000 and below	Exposed to water splashes	-15 to +100, +5 to +212	30 to 100	1 day To 1 week.

7.4 Standard location of the grease fitting

Standard location of grease fitting on the housing for the relubricatable bearing units of each type is illustrated below.

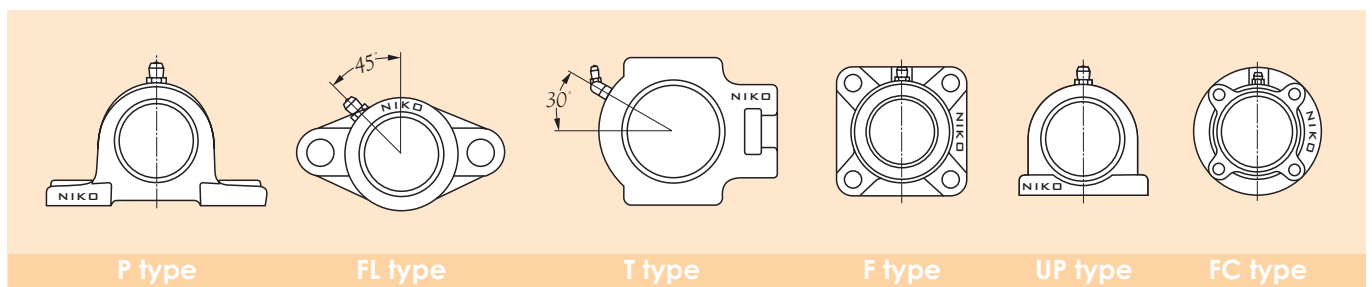

8. Shaft Designs

Although the shafts used for **NIKO** bearing units require no particularly high standards of accuracy, it is desirable that, as far as possible, they are free from bends and flaws.

8.1 Set screw system bearing units with set screw system bearing units, under normal operating conditions the inner ring is usually fitted onto the shaft by means of a clearance fit to ensure convenience of assembly. In this case the values shown in Fig. 8.1 are appropriate dimensional tolerances for the shaft.

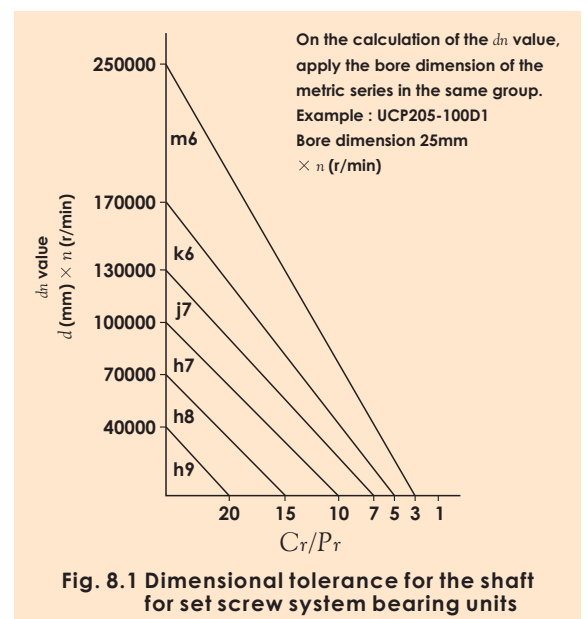

Fig. 8.1 Dimensional tolerance for the shaft for set screw system bearing units

Step shafts

Whenever there is a noticeably large axial load, a step shaft, as shown in Fig. 8.2, should, if practical, be used.

As an expedient, there may be provided a bored hole on the shaft as illustrated in Fig. 8.3. In this case it is necessary to ensure the accuracy of the relationship between the positions of the housing of the bearing and of the bored hole on the shaft.

Table 8.2 Radial of the round corners of step shafts

Designation of bearings	ras max. mm
UC 201 to UC 203	0.6
UC 204 to UC 206	1.0
UC 207 to UC 210	1.5
UC 211 to UC 215	2.0
UC 216 to UC 218	2.5

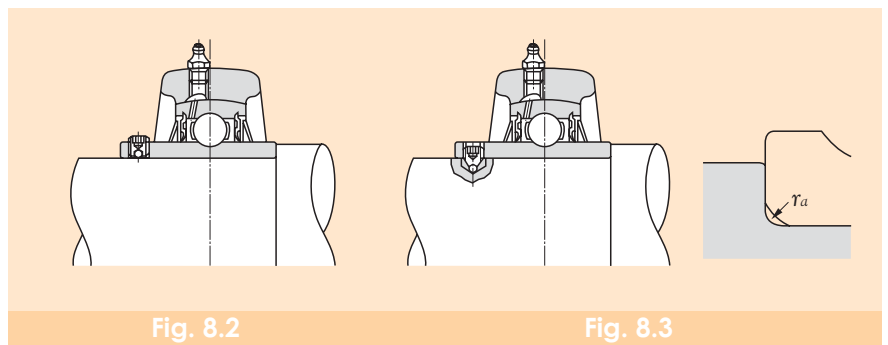

Relief in the axial direction

Where several bearing units are fitted on the shaft, or where there is a great distance between two bearing units, one of the bearings is secured to the shaft as the "fixed-side bearing" and is subjected to both the axial and radial loads. The other is mounted on the shaft as the "free-side bearing" and is subjected only to radial load, compensating for expansion of the shaft due to a rise in temperature or for any errors in the distance between bearings that may have occurred during assembly.

If there is no free-side bearing, the bearings will be subjected to an abnormal axial load, which could cause premature breakdown.

Although it is desirable to use a cartridge-type bearing unit for the above purpose (Fig. 8.4), the following method is often employed. As illustrated in Fig. 8.5 (a) and (b), a key way is cut in the shaft, to accommodate a special set screw.

When relief is provided in the axial direction by the use of screwed bolts as above, the dimensional relationships applicable are as shown in Table 8.3 (a) and 8.3 (b) on the following pages.

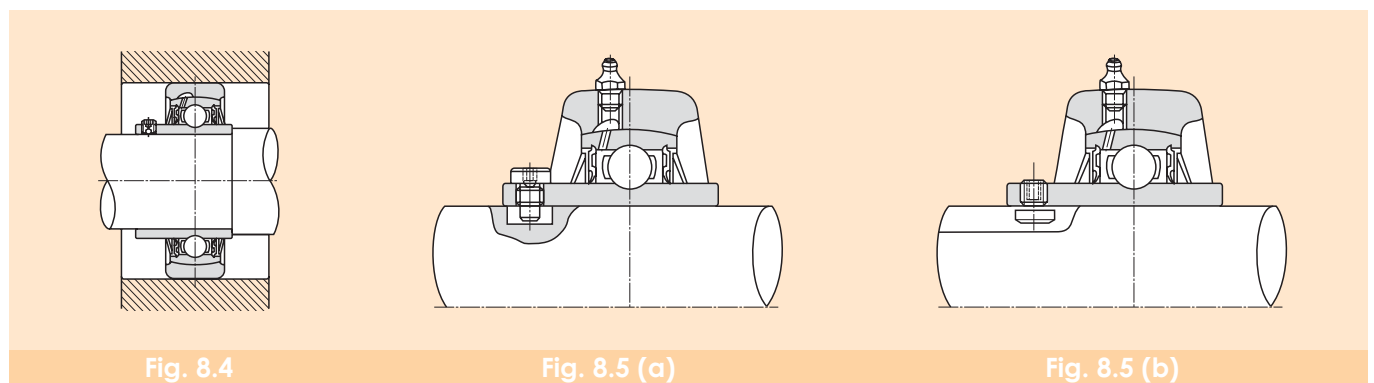



Table 8.3 Screwed bolt system (Metric series, applied to metric bore size.)

(Unit : mm)

Designation of bearings	Key way		Designation and size of bolts	d_1	l	l_1	D	H
	Width b	Depth h						
UC 201 D1 W5	3.5	3.0	S5W 5 x 0.80 x 11.0	3.5	11.0	5.0	6	3
UC 202 D1 W5	3.5	4.5	S5W 5 x 0.80 x 11.0	3.5	11.0	5.0	6	3
UC 203 D1 W5	3.5	5.5	S5W 5 x 0.80 x 11.0	3.5	11.0	5.0	6	3
UC 204 D1 W5	3.5	4.5	S5W 5 x 0.80 x 8.5	3.5	8.5	5.0	6	3
UC 205 D1 W5	3.5	5.0	S5W 5 x 0.80 x 8.5	3.5	8.5	5.0	6	3
UC 206 D1 W5	4.0	5.5	S5W 6 x 0.75 x 10.0	4.0	10.0	5.9	8	3
UC 207 D1 W5	4.0	5.0	S5W 6 x 0.75 x 10.0	4.0	10.0	5.9	8	3
UC 208 D1 W5	6.0	5.5	S5W 8 x 1.00 x 11.5	6.0	11.5	5.5	10	3
UC 209 D1 W5	6.0	6.0	S5W 8 x 1.00 x 11.5	6.0	11.5	5.5	10	3
UC 210 D1 W5	6.0	6.0	S5W 8 x 1.00 x 11.5	6.0	11.5	5.5	10	3
UC 211 D1 W5	6.0	5.5	S5W 8 x 1.00 x 11.5	6.0	11.5	5.5	10	3
UC 212 D1 W5	7.0	5.5	S5W10 x 1.25 x 13.5	7.0	13.5	6.5	12	3
UC 213 D1 W5	7.0	5.5	S5W10 x 1.25 x 13.5	7.0	13.5	6.5	12	3
UC 214 D1 W5	7.0	5.5	S5W10 x 1.25 x 13.5	7.0	13.5	6.5	12	3
UC 215 D1 W5	7.0	5.0	S5W10 x 1.25 x 13.5	7.0	13.5	6.5	12	3
UC 216 D1 W5	7.0	6.5	S5W10 x 1.25 x 15.0	7.0	15.0	7.0	12	3
UC 217 D1 W5	9.0	6.5	S5W12 x 1.50 x 16.5	9.0	16.5	7.0	14	4
UC 218 D1 W5	9.0	6.5	S5W12 x 1.50 x 16.5	9.0	16.5	7.0	14	4

Note : The tolerance for the width (b) of the key way should preferably be set at the range of 0 to +0.2 mm.

8.2 Eccentric collar system

As in the case of the set screw system, it is usual under normal operating conditions to fit the inner ring onto the shaft by means of a clearance fit, for ease of assembly. Fig. 8.6 shows the appropriate values of dimensional tolerances for the shaft.

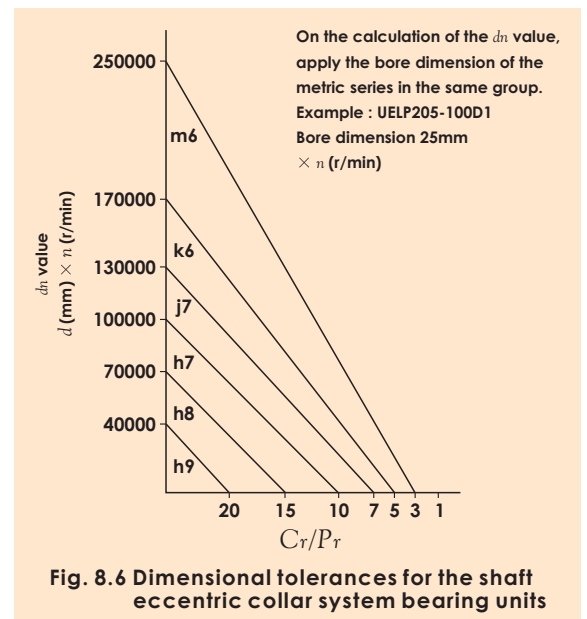

Fig. 8.6 Dimensional tolerances for the shaft eccentric collar system bearing units

9. Handling of the Bearing Unit

9.1 Mounting of the housing

9.1.1 Pillow block type and flange type

Although an advantage of the **NIKO** bearing unit is that it can be fitted easily and will function efficiently on any part of a machine, attention must be paid to the following points in order to ensure its normal service life.

- (1) The surface on which the housing is mounted must be sufficiently rigid.
- (2) The surface on which the housing is mounted should be as flat as possible (The housing should set firmly in its position). Deformation of the housing caused by incorrect mounting will in turn cause deformation of the bearing, leading to its premature breakdown.
- (3) It is desirable that the angle between the surface on which the housing is mounted and the shaft be maintained to a tolerance of $\pm 2^\circ$.
- (4) The pillow block type and flange type housings are provided with a seat for a dowel for accurate location. For the use of dowel pins, refer to Table 9.1.

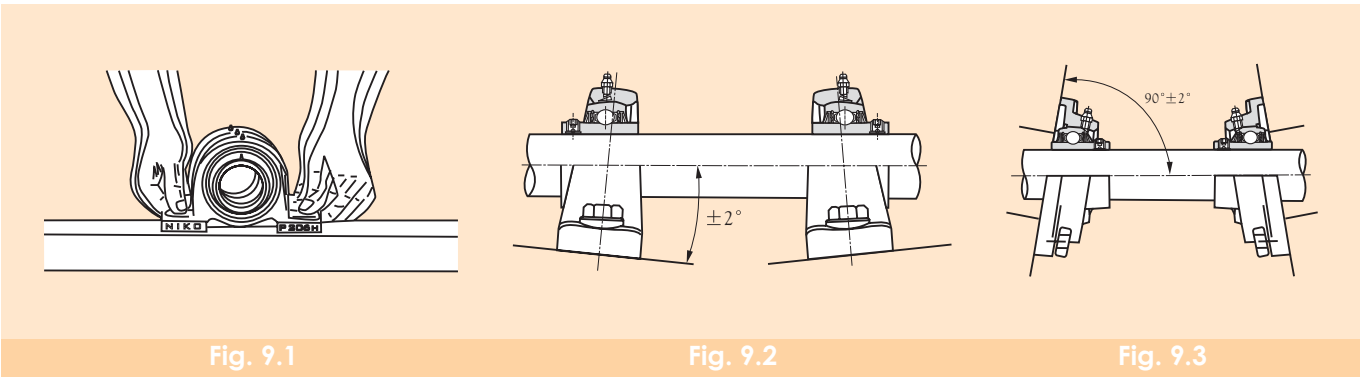
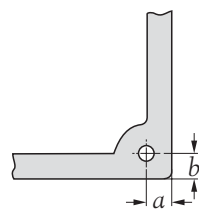
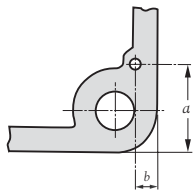

Table 9.1 Recommended dimensions of dowel pins
(Unit : mm)

Designation of the housings	a	b	Recommended pin diameter
P 203	5.5	5.5	3
P 204	5.5	5.5	3
P 205	5.5	5.5	3
P 206	5.5	5.5	3
P 207	5.5	5.5	3
P 208	7.0	7.0	5
P 209	7.0	7.0	5
P 210	7.5	7.5	5
P 211	7.5	7.5	5
P 212	9.0	9.0	7
P 213	9.0	9.0	7
P 214	9.0	9.0	7
P 215	9.0	9.0	7
P 216	10.0	10.0	7
P 217	12.0	12.0	10
P 218	12.0	12.0	10





(Unit : mm)

Designation of the housings	a	b	Recommended pin diameter
F 204	33	6	4
F 205	35	6	4
F 206	35	6	4
F 207	38	7	5
F 208	40	8	5
F 209	43	8	5
F 210	49	8	5
F 211	49	8	5
F 212	49	8	5
F 213	52	9	6
F 214	52	9	6
F 215	52	9	6
F 216	55	12	6
F 217	55	12	6
F 218	61	14	6

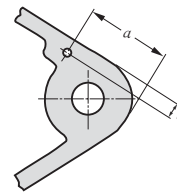

(Unit : mm)

Designation of the housings	a	b	Recommended pin diameter
FL 204	22	10	4
FL 205	28	10	4
FL 206	33	12	4
FL 207	30	14	5
FL 208	33	15	5
FL 209	38	15	5
FL 210	39	16	5
FL 211	44	18	5
FL 212	54	19	5
FL 213	53	18	6
FL 214	53	18	6
FL 215	55	21	6
FL 216	55	21	6
FL 217	55	21	6
FL 218	55	22	6

9.1.2 Cartridge type

The inside diameter of the housing into which a cartridge type unit is inserted should be H7 under general operating conditions. It should be so furnished as to permit the bearing unit to move freely in the axial direction.

9.2 Mounting the bearing unit on the shaft

9.2.1 Mounting of the set screw system unit

To mount the set screw system bearing unit on the shaft, it is sufficient to tighten the two set screws uniformly.

The construction of the **NIKO** "Ball-End Set Screw" is illustrated in Fig. 9.4 with the pin design that prevents it from becoming loose even when it is subjected to vibrations or impact loads.

If the fit clearance between the inner ring and the shaft is very small, it is advisable, prior to fastening on the screw, to file off that part of the shaft at which the end of the set screw (ball) strikes, by approximately 0.2 to 0.5mm 0.01 to 0.02 inches, to flatten it, as illustrated in Fig. 9.5.

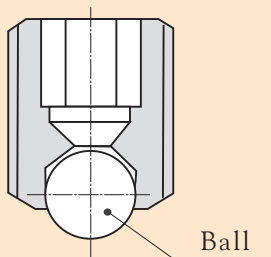

Fig. 9.4

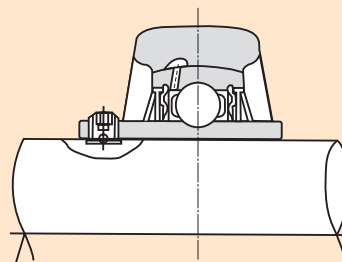

Fig. 9.5

This will facilitate dismounting of the bearing from the shaft to become necessary.

The method of mounting the unit on the shaft is as follows:

- 1) Make certain that the end of the set screw is not protruding into the bore of the bearing.
- 2) Holding the unit at right angles to the shaft, insert the shaft into the bore of the bearing without twisting the bearing. Take care not to strike the slinger nor to subject the unit to any shock (Fig. 9.6).
- 3) Insert a hexagonal bar wrench securely into the hexagonal hole of the set screw, and tighten the two screws uniformly. Use the tightening torque shown in Table 9.2.
- 4) Mount the housing securely in position on the machine, Sometimes the order of steps 3) and 4) is reversed.

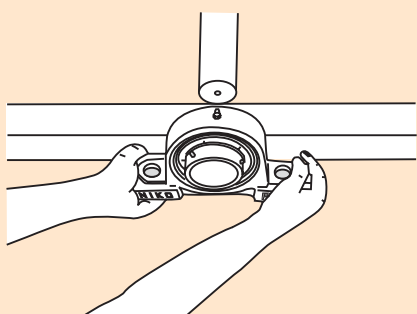

Fig. 9.6

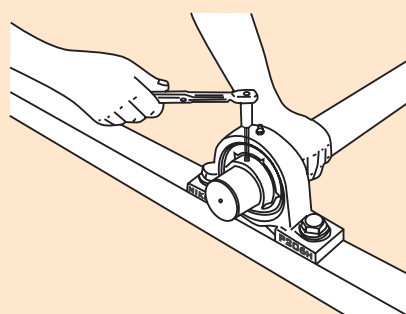

Fig. 9.7

**Table 9.2 Recommended torques for tightening set screws
(Metric series, applied to metric bore size.)**

Designation of the bearings of applicable units	Designation of set screws	Tightening torques N.m (max.)
UC 201 to UC 205	M 5 x 0.8 x 7	3.9
UC 206	M 6 x 0.75 x 8	4.9
UC 207	M 6 x 0.75 x 8	5.8
UC 208 to UC 210	M 8 x 1 x 10	7.8
UC 211	M 8 x 1 x 10	9.8
UC 212	M10 x 1.25 x 12	16.6
UC 213 to UC 215	M10 x 1.25 x 12	19.6
UC 216	M10 x 1.25 x 12	22.5
UC 217 to UC 218	M12 x 1.5 x 13	29.4

Designation of the bearings of applicable units	Designation of set screws	Tightening torques N.m (max.)
AS 201 to 205	M5 x 0.8 x 7	3.4
AS 206	M6 x 0.75 x 8	4.4
AS 207	M6 x 0.75 x 8	4.9
AS 208	M8 x 1 x 10	6.8

9.2.2 Mounting the eccentric locking collar system unit

In this system, unlike the screw system, the shaft and inner ring are fastened together by fastening the eccentric collar in the direction of the rotation of the shaft. They are fastened together securely, and deformation of the inner ring seldom occurs. This system, however, is not recommended for applications where the direction of rotation is sometimes reversed.

Directions for mounting the unit are as follows:

- 1) Make certain that the frame in which the housing is to be mounted is suitable to the operating conditions with regard to rigidity, flatness, etc.
- 2) Make sure that the end of the shaft is not burred and that the end of the set screw in the eccentric collar is not protruding from the interior surface of the collar (Fig. 9.8).
- 3) Mount the housing of the unit securely onto the frame.
- 4) Determine the relative position of the unit and the shaft accurately so that the unit will not be subjected to any thrust, and then insert the eccentric collar (Fig. 9.9).

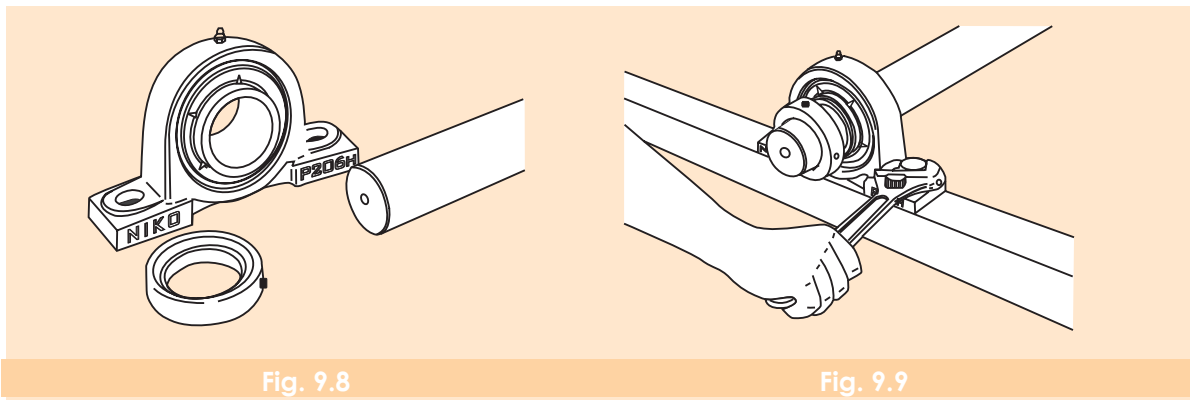

- 5) Fit the eccentric circular ridge provided on the inner ring into the eccentric circular groove of the eccentric collar, and then provisionally tighten by turning the collar by hand in the direction of the shaft (Fig. 9.10).
- 6) Insert a bar into the hole provided on the periphery of the eccentric collar and tap the bar so that the collar turns in the direction of rotation of the shaft (see Fig. 9.11).
- 7) Fasten the set screw of the eccentric collar onto the shaft. Recommended tightening torques are given in Table 9.3.

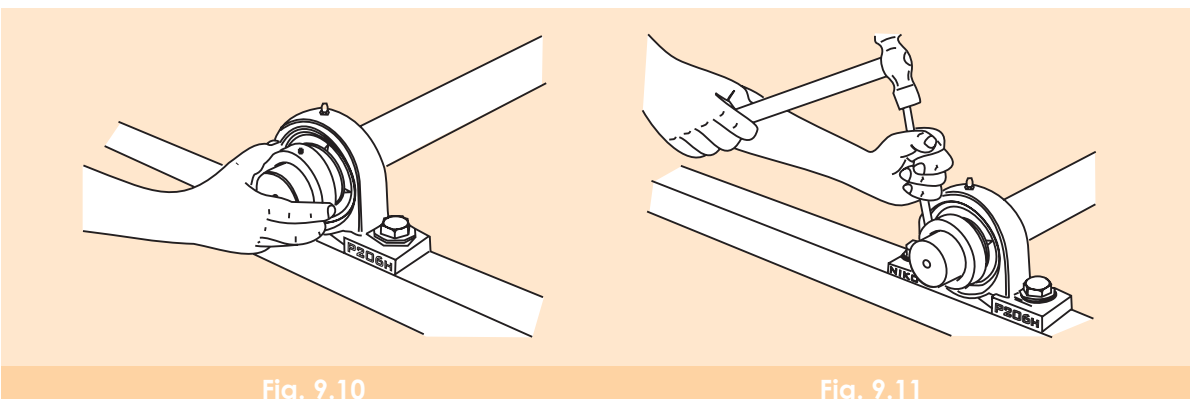

9.2.3 Mounting covered bearing units

For selection of the shaft, mounting the bearing onto the shaft and fitting the housing follow the same procedure as for standard bearing units. Furthermore, fitting the cover presents no special difficulty, with no need for special tools or jigs.

The procedure for mounting covered bearing units is as follows:

- 1) Remove the cover from the bearing unit. The steel cover can usually be removed easily by hand, but should there be any difficulty due to an over-tight fit, insert a screwdriver or similar tool in a twisting motion, as shown in Fig. 9.12.
- 2) In order to augment the dust and waterproofing effects, completely fill the space between the two lips of the rubber seal incorporated in the cover with grease, and apply grease to the inside of the cover, filling about two-thirds of the space. Cup grease is commonly used for this purpose (Fig. 9.13).

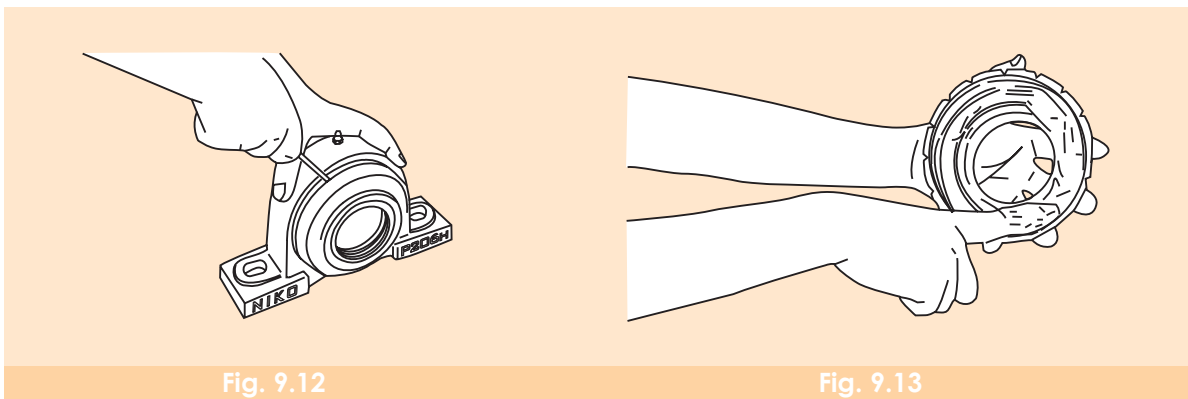

Fig. 9.12

Fig. 9.13

- 3) First, pass one of the two grease-packed covers along the shaft, and then slide the bearing unit onto the shaft and fix the inner ring fast on the shaft before tightening the bolts holding the housing. Sometimes these steps are reversed for convenience of assembly. It is recommended that the end of the shaft be chamfered beforehand to avoid damaging the lips of the rubber seal.
- 4) Next take the cover which has been passed along the shaft and press it into the housing as follows: Be Careful not to strike the surface of the steel cover directly with a steel hammer but use a synthetic resin or wood block in between. Do not strike only in one place but tap the cover all the way round until it is firmly seated in the housing. (Fig. 9.14).
- 5) Pack the second cover with grease as in step 2 and pass it along the shaft. In the case of a blind cover, the recess of the housing should be filled with grease (Fig. 9.13).
- 6) Fit the cover into the recess of the housing using the same procedure as detailed in Step 4) (Fig. 9.15).

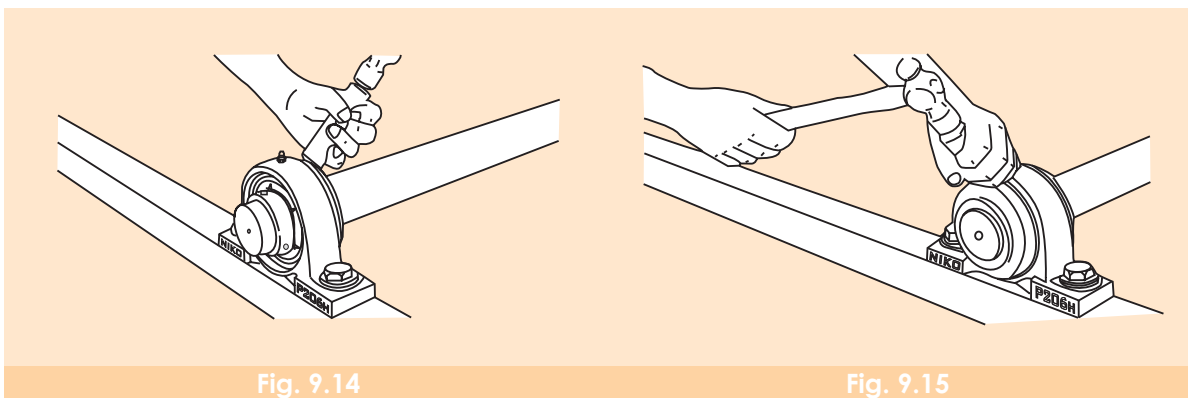

Fig. 9.14

Fig. 9.15

9.3 Running tests

After mounting the bearing unit, check that it has been done correctly.

First, turn the shaft or the rotor by hand to make certain that it rotates smoothly. If there is no irregularity, start up the machine. Run the machine at low speed under no load and gradually bring it up to full operating speed while checking that there are no abnormalities.

Some indications of abnormality of faulty assembly are as follows:

When the shaft is turned by hand a resistance or drag is felt, or the shaft appears to become heavy or light in turn. Or, if the machine is running under power, any abnormal noise, vibration or overheating is evident.

9.4 Inspection during operation

Although the **NIKO** lubrication-free bearing unit does not require refilling with grease while in use, periodic inspections are necessary to ensure safe operation of the unit's most important parts. While the interval between inspections varies from case to case, according to the degree of importance and the rate of operation, it is usually some time between two weeks and a month.

Since the inside of the bearing can be examined only by removing the slinger, seal etc., The condition of the bearing should be judged by checking for the presence of vibration, noise, overheating of the housing, etc., while the machine is running.

9.5 Dismounting the bearing unit

If some abnormality makes it necessary to dismount the bearing unit from the shaft in order to replace it, the procedure used to mount the bearing is followed in reverse order. In this case, special care should be given to the following points:

1) Set screw system units:

If the set screw is protruding into the bore of the bearing when the unit is withdrawn from the shaft, it will damage the shaft. Therefore the screw should be turned back fully.

2) Adapter system units:

To remove an adapter system bearing unit from the shaft, raise the tab of the washer, turn the nut two or three turns back, and apply a metal block to the nut and tap it with a hammer. Do this all round the nut, until the sleeve can be moved (Fig. 9.16).

If the nut is turned back too far and the screws are only slightly engaged, tapping to remove it will eventually ruin the screws.

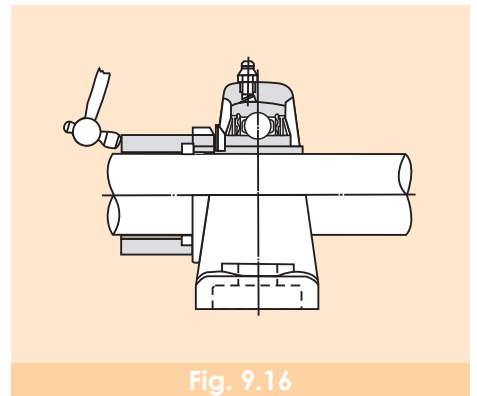

Fig. 9.16

9.6 Replacement of the bearing

If the bearing in the **NIKO** bearing unit needs to be replaced, this can be carried out simply with a plummer block. There is no need to replace the housing, as it is reusable.

The bearing is changed using the following procedure: First, the set screw should be tightened as much as possible. Otherwise, there is a danger that it may catch in the housing when the bearing is tilted.

Next, insert the handle of a hammer or similar tool into the bore of the bearing and twist. Tilt the bearing through a full 90°, and pull it in the direction of the notch on the housing to remove it. To install a new bearing in the housing, follow the same procedure in reverse.



DIMENSION TABLES

PILLOW BLOCKS CAST HOUSINGS (SET SCREW TYPE)
SERIES UCP 200

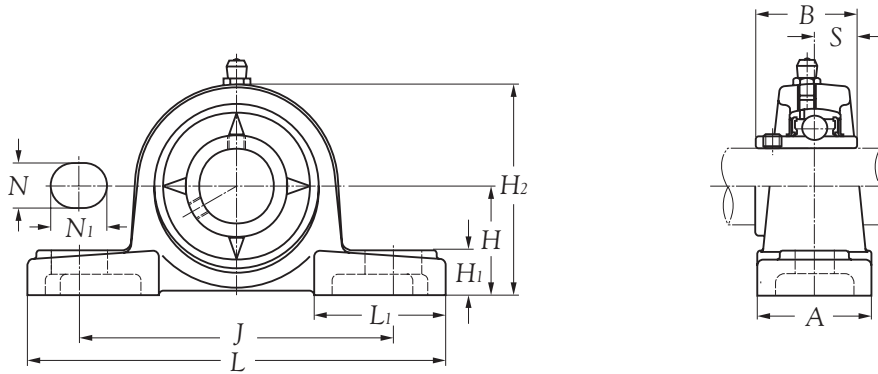

Shaft dia. mm	Unit number	Nominal dimensions										
		<i>H</i>	<i>L</i>	<i>J</i>	<i>A</i>	<i>N</i>	<i>N_i</i>	<i>H₁</i>	<i>H₂</i>	<i>L₁</i>	<i>B</i>	<i>S</i>
12	UCP 201 (H)	30.2	127	95	38	13	16	14	62	42	31.0	12.7
15	UCP 202 (H)	30.2	127	95	38	13	16	14	62	42	31.0	12.7
17	UCP 203 (H)	30.2	127	95	38	13	16	14	62	42	31.0	12.7
20	UCP 204 (H)	33.3	127	95	38	13	16	14	65	42	31.0	12.7
25	UCP 205 (H)	36.5	140	105	38	13	16	15	71	42	34.1	14.3
30	UCP 206 (H)	42.9	165	121	48	17	20	17	83	54	38.1	15.9
35	UCP 207 (H)	47.6	167	127	48	17	20	18	93	54	42.9	17.5
40	UCP 208 (H)	49.2	184	137	54	17	20	18	98	52	49.2	19.0
45	UCP 209 (H)	54.0	190	146	54	17	20	20	106	60	49.2	19.0
50	UCP 210 (H)	57.2	206	159	60	20	23	21	114	65	51.6	19.0
55	UCP 211 (H)	63.5	219	171	60	20	23	23	126	65	55.6	22.2
60	UCP 212 (H)	69.8	241	184	70	20	23	25	138	70	65.1	25.4
65	UCP 213 (H)	76.2	265	203	70	25	28	27	151	77	65.1	25.4
70	UCP 214 (H)	79.4	266	210	72	25	28	27	157	77	74.6	30.2
75	UCP 215 (H)	82.6	275	217	74	25	28	28	163	80	77.8	33.3
80	UCP 216 (H)	88.9	292	232	78	25	28	30	175	85	82.6	33.3
85	UCP 217 (H)	95.2	310	247	83	25	28	32	187	85	85.7	34.1
90	UCP 218 (H)	101.6	327	262	88	27	30	33	200	90	96.0	39.7

PILLOW BLOCKS CAST HOUSINGS (SET SCREW TYPE)
SERIES UCP 200

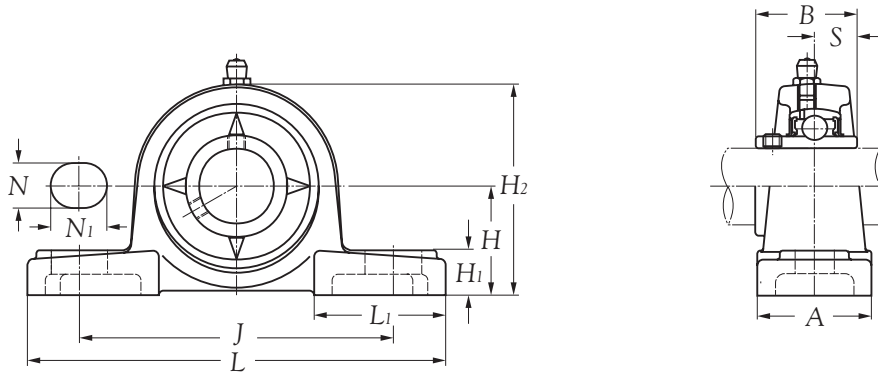

Bolt size mm	Bearing number	Housing number	Mass of unit kg
M10	UC 201 (D1)	P 201 (H)	0.7
M10	UC 202 (D1)	P 202 (H)	0.7
M10	UC 203 (D1)	P 203 (H)	0.7
M10	UC 204 (D1)	P 204 (H)	0.7
M10	UC 205 (D1)	P 205 (H)	0.8
M14	UC 206 (D1)	P 206 (H)	1.3
M14	UC 207 (D1)	P 207 (H)	1.6
M14	UC 208 (D1)	P 208 (H)	1.9
M14	UC 209 (D1)	P 209 (H)	2.2
M16	UC 210 (D1)	P 210 (H)	2.6
M16	UC 211 (D1)	P 211 (H)	3.3
M16	UC 212 (D1)	P 212 (H)	4.6
M20	UC 213 (D1)	P 213 (H)	5.9
M20	UC 214 (D1)	P 214 (H)	6.6
M20	UC 215 (D1)	P 215 (H)	7.4
M20	UC 216 (D1)	P 216 (H)	9.0
M20	UC 217 (D1)	P 217 (H)	11.0
M22	UC 218 (D1)	P 218 (H)	13.0

FLANGED UNITS CAST HOUSINGS (SET SCREW TYPE)
SERIES UCF 200

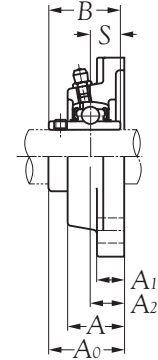
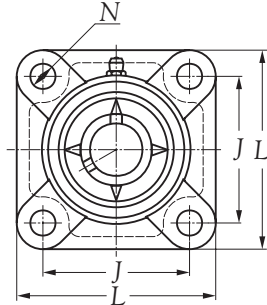

Shaft dia. mm	Unit number	Nominal dimensions								
		L	J	A ₂	A ₁	mm A	N	A ₀	B	S
12	UCF 201 (H)	86	64	15	11	25.5	12	33.3	31.0	12.7
15	UCF 202 (H)	86	64	15	11	25.5	12	33.3	31.0	12.7
17	UCF 203 (H)	86	64	15	11	25.5	12	33.3	31.0	12.7
20	UCF 204 (H)	86	64	15	11	25.5	12	33.3	31.0	12.7
25	UCF 205 (H)	95	70	16	13	27.0	12	35.8	34.1	14.3
30	UCF 206 (H)	108	83	18	13	31.0	12	40.2	38.1	15.9
35	UCF 207 (H)	117	92	19	15	34.0	14	44.4	42.9	17.5
40	UCF 208 (H)	130	102	21	15	36.0	16	51.2	49.2	19.0
45	UCF 209 (H)	137	105	22	16	38.0	16	52.2	49.2	19.0
50	UCF 210 (H)	143	111	22	16	40.0	16	54.6	51.6	19.0
55	UCF 211 (H)	162	130	25	18	43.0	19	58.4	55.6	22.2
60	UCF 212 (H)	175	143	29	18	48.0	19	68.7	65.1	25.4
65	UCF 213 (H)	187	149	30	22	50.0	19	69.7	65.1	25.4
70	UCF 214 (H)	193	152	31	22	54.0	19	75.4	74.6	30.2
75	UCF 215 (H)	200	159	34	22	56.0	19	78.5	77.8	33.3
80	UCF 216 (H)	208	165	34	22	58.0	23	83.3	82.6	33.3
85	UCF 217 (H)	220	175	36	24	63.0	23	87.6	85.7	34.1
90	UCF 218 (H)	235	187	40	24	68.0	23	96.3	96.0	39.7

FLANGED UNITS CAST HOUSINGS (SET SCREW TYPE)
SERIES UCF 200

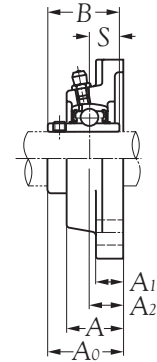
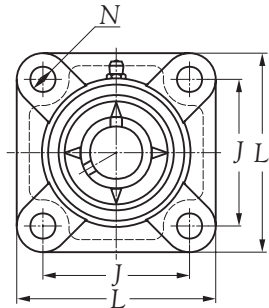

Bolt size mm	Bearing number	Housing number	Mass of unit kg
M10	UC 201 (D1)	F 204 (H)	0.7
M10	UC 202 (D1)	F 204 (H)	0.7
M10	UC 203 (D1)	F 204 (H)	0.6
M10	UC 204 (D1)	F 204 (H)	0.6
M10	UC 205 (D1)	F 205 (H)	0.8
M10	UC 206 (D1)	F 206 (H)	1.0
M12	UC 207 (D1)	F 207 (H)	1.4
M14	UC 208 (D1)	F 208 (H)	1.8
M14	UC 209 (D1)	F 209 (H)	2.2
M14	UC 210 (D1)	F 210 (H)	2.4
M16	UC 211 (D1)	F 211 (H)	3.6
M16	UC 212 (D1)	F 212 (H)	4.4
M16	UC 213 (D1)	F 213 (H)	5.5
M16	UC 214 (D1)	F 214 (H)	6.1
M16	UC 215 (D1)	F 215 (H)	6.9
M20	UC 216 (D1)	F 216 (H)	8.1
M20	UC 217 (D1)	F 217 (H)	9.3
M22	UC 218 (D1)	F 218 (H)	11.0

FLANGED UNITS CAST HOUSINGS (SET SCREW TYPE)
SERIES UCFL 200

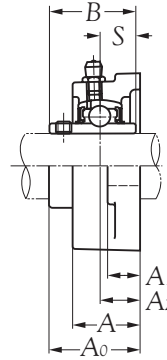
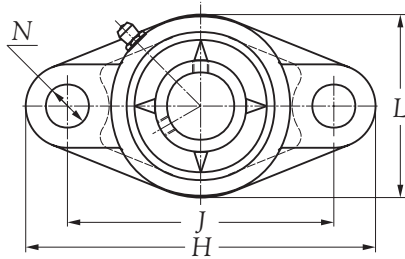

Shaft dia. mm	Unit number	Nominal dimensions									
		H	J	A ₂	A ₁	A	N	L	A ₀	B	S
12	UCFL 201 (H)	113	90	15	11	25.5	12	60	33.3	31.0	12.7
15	UCFL 202 (H)	113	90	15	11	25.5	12	60	33.3	31.0	12.7
17	UCFL 203 (H)	113	90	15	11	25.5	12	60	33.3	31.0	12.7
20	UCFL 204 (H)	113	90	15	11	25.5	12	60	33.3	31.0	12.7
25	UCFL 205 (H)	130	99	16	13	27.0	16	68	35.8	34.1	14.3
30	UCFL 206 (H)	148	117	18	13	31.0	16	80	40.2	38.1	15.9
35	UCFL 207 (H)	161	130	19	15	34.0	16	90	44.4	42.9	17.5
40	UCFL 208 (H)	175	144	21	15	36.0	16	100	51.2	49.2	19.0
45	UCFL 209 (H)	188	148	22	16	38.0	19	108	52.2	49.2	19.0
50	UCFL 210 (H)	197	157	22	16	40.0	19	115	54.6	51.6	19.0
55	UCFL 211 (H)	224	184	25	18	43.0	19	130	58.4	55.6	22.2
60	UCFL 212 (H)	250	202	29	18	48.0	23	140	68.7	65.1	25.4
65	UCFL 213 (H)	258	210	30	22	50.0	23	155	69.7	65.1	25.4
70	UCFL 214 (H)	265	216	31	22	54.0	23	160	75.4	74.6	30.2
75	UCFL 215 (H)	275	225	34	22	56.0	23	165	78.5	77.8	33.3
80	UCFL 216 (H)	290	233	34	22	58.0	25	180	83.3	82.6	33.3
85	UCFL 217 (H)	305	248	36	24	63.0	25	190	87.6	85.7	34.1
90	UCFL 218 (H)	320	265	40	24	68.0	25	205	96.3	96.0	39.7

FLANGED UNITS CAST HOUSINGS (SET SCREW TYPE)
SERIES UCFL 200

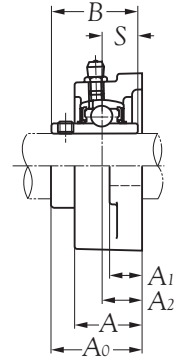
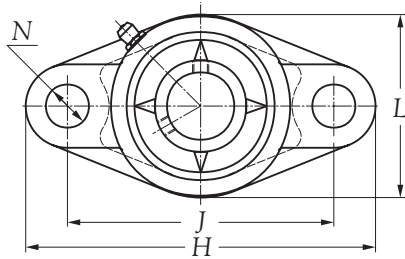

Bolt size mm	Bearing number	Housing number	Mass of unit kg
M10	UC 201 (D1)	FL 204 (H)	0.6
M10	UC 202 (D1)	FL 204 (H)	0.6
M10	UC 203 (D1)	FL 204 (H)	0.6
M10	UC 204 (D1)	FL 204 (H)	0.6
M14	UC 205 (D1)	FL 205 (H)	0.6
M14	UC 206 (D1)	FL 206 (H)	0.9
M14	UC 207 (D1)	FL 207 (H)	1.2
M14	UC 208 (D1)	FL 208 (H)	1.6
M16	UC 209 (D1)	FL 209 (H)	1.9
M16	UC 210 (D1)	FL 210 (H)	2.2
M16	UC 211 (D1)	FL 211 (H)	3.1
M20	UC 212 (D1)	FL 212 (H)	4.0
M20	UC 213 (D1)	FL 213 (H)	5.0
M20	UC 214 (D1)	FL 214 (H)	5.6
M20	UC 215 (D1)	FL 215 (H)	6.2
M22	UC 216 (D1)	FL 216 (H)	8.2
M22	UC 217 (D1)	FL 217 (H)	9.3
M22	UC 218 (D1)	FL 218 (H)	11.0

FLANGED CARTRIDGE UNITS CAST HOUSINGS (SET SCREW TYPE)
SERIES UCFC 200

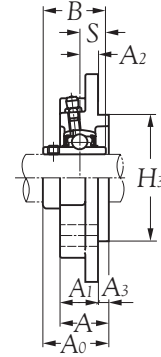
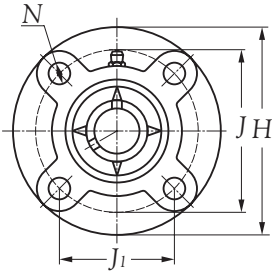

Shaft dia. mm	Unit number	Nominal dimensions											
		H	J	J ₁	A ₂	N	A ₃	A ₁	A	H ₃	A ₀	B	S
12	UCFC 201 (H)	100	78	55.1	10	12	5	20.5	25.5	62	33.3	31.0	12.7
15	UCFC 202 (H)	100	78	55.1	10	12	5	20.5	25.5	62	33.3	31.0	12.7
17	UCFC 203 (H)	100	78	55.1	10	12	5	20.5	25.5	62	33.3	31.0	12.7
20	UCFC 204 (H)	100	78	55.1	10	12	5	20.5	25.5	62	33.3	31.0	12.7
25	UCFC 205 (H)	115	90	63.6	10	12	6	21.0	27.0	70	35.8	34.1	14.3
30	UCFC 206 (H)	125	100	70.7	10	12	8	23.0	31.0	80	40.2	38.1	15.9
35	UCFC 207 (H)	135	110	77.8	11	14	8	26.0	34.0	90	44.4	42.9	17.5
40	UCFC 208 (H)	145	120	84.8	11	14	10	26.0	36.0	100	51.2	49.2	19.0
45	UCFC 209 (H)	160	132	93.3	10	16	12	26.0	38.0	105	52.2	49.2	19.0
50	UCFC 210 (H)	165	138	97.6	10	16	12	28.0	40.0	110	54.6	51.6	19.0
55	UCFC 211 (H)	185	150	106.1	13	19	12	31.0	43.0	125	58.4	55.6	22.2
60	UCFC 212 (H)	195	160	113.1	17	19	12	36.0	48.0	135	68.7	65.1	25.4
65	UCFC 213 (H)	205	170	120.2	16	19	14	36.0	50.0	145	69.7	65.1	25.4
70	UCFC 214 (H)	215	177	125.1	17	19	14	40.0	44.0	150	75.4	74.6	30.2
75	UCFC 215 (H)	220	184	130.1	18	19	16	40.0	56.0	160	78.5	77.8	33.3
80	UCFC 216 (H)	240	200	141.4	18	23	16	42.0	58.0	170	83.3	82.6	33.3
85	UCFC 217 (H)	250	208	147.1	18	23	18	45.0	63.0	180	87.6	85.7	34.1
90	UCFC 218 (H)	265	220	155.5	22	23	18	50.0	68.0	190	96.3	96.0	39.7

FLANGED CARTRIDGE UNITS CAST HOUSINGS (SET SCREW TYPE)
SERIES UCFC 200

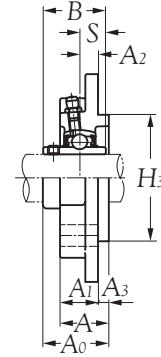
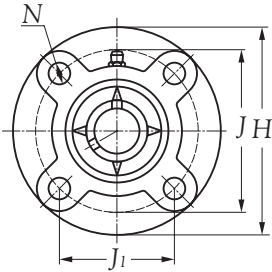

Bolt size mm	Bearing number	Housing number	Mass of unit kg
M10	UC 201 (D1)	FC 204 (H)	0.8
M10	UC 202 (D1)	FC 204 (H)	0.8
M10	UC 203 (D1)	FC 204 (H)	0.8
M10	UC 204 (D1)	FC 204 (H)	0.8
M10	UC 205 (D1)	FC 205 (H)	1.0
M10	UC 206 (D1)	FC 206 (H)	1.3
M12	UC 207 (D1)	FC 207 (H)	1.6
M12	UC 208 (D1)	FC 208 (H)	2.1
M14	UC 209 (D1)	FC 209 (H)	2.7
M14	UC 210 (D1)	FC 210 (H)	3.1
M16	UC 211 (D1)	FC 211 (H)	4.2
M16	UC 212 (D1)	FC 212 (H)	5.3
M16	UC 213 (D1)	FC 213 (H)	6.0
M16	UC 214 (D1)	FC 214 (H)	7.0
M16	UC 215 (D1)	FC 215 (H)	7.8
M20	UC 216 (D1)	FC 216 (H)	9.3
M20	UC 217 (D1)	FC 217 (H)	11.0
M20	UC 218 (D1)	FC 218 (H)	13.0

TAKE-UP UNITS CAST HOUSINGS (SET SCREW TYPE)
SERIES UCT 200

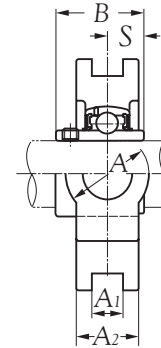
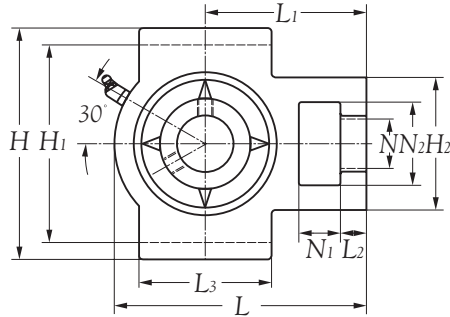

Shaft dia. mm	Unit number	Nominal dimensions															
		mm															
		N_1	L_2	H_2	N_2	N	L_3	A_1	H_1	H	L	A_2	A	r	L_1	B	S
12	UCT 201 (H)	16	12	51	32	19	51	12	76	89	94	21	32	33	61	31.0	12.7
15	UCT 202 (H)	16	12	51	32	19	51	12	76	89	94	21	32	33	61	31.0	12.7
17	UCT 203 (H)	16	12	51	32	19	51	12	76	89	94	21	32	33	61	31.0	12.7
20	UCT 204 (H)	16	12	51	32	19	51	12	76	89	94	21	32	33	61	31.0	12.7
25	UCT 205 (H)	16	12	51	32	19	51	12	76	89	97	24	32	35	62	34.1	14.3
30	UCT 206 (H)	16	12	56	37	22	57	12	89	102	113	28	37	43	70	38.1	15.9
35	UCT 207 (H)	16	15	64	37	22	64	12	89	102	129	30	37	51	78	42.9	17.5
40	UCT 208 (H)	19	18	83	49	29	83	16	102	114	144	33	49	56	88	49.2	19.0
45	UCT 209 (H)	19	18	83	49	29	83	16	102	117	145	35	49	57	88	49.2	19.0
50	UCT 210 (H)	19	18	83	49	29	86	16	102	117	151	37	49	59	92	51.6	19.0
55	UCT 211 (H)	25	21	102	64	35	95	22	130	146	171	38	64	65	106	55.6	22.2
60	UCT 212 (H)	32	21	102	64	35	102	22	130	146	194	42	64	75	119	65.1	25.4
65	UCT 213 (H)	32	23	111	70	41	121	26	151	167	224	44	70	87	137	65.1	25.4
70	UCT 214 (H)	32	23	111	70	41	121	26	151	167	224	46	70	87	137	74.6	30.2
75	UCT 215 (H)	32	23	111	70	41	121	26	151	167	232	48	70	92	140	77.8	33.3
80	UCT 216 (H)	32	23	111	70	41	121	26	165	184	235	51	70	95	140	82.6	33.3
85	UCT 217 (H)	38	31	124	73	48	157	30	173	198	260	54	73	98	162	85.7	34.1

TAKE-UP UNITS CAST HOUSINGS (SET SCREW TYPE)
SERIES UCT 200

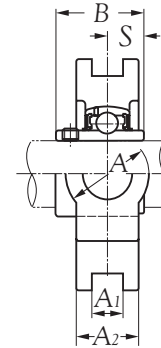
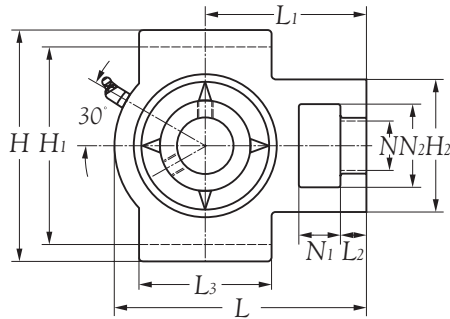

Bearing number	Housing number	Mass of unit kg
UC 201 (D1)	T 204 (H)	0.8
UC 202 (D1)	T 204 (H)	0.8
UC 203 (D1)	T 204 (H)	0.8
UC 204 (D1)	T 204 (H)	0.8
UC 205 (D1)	T 205 (H)	0.9
UC 206 (D1)	T 206 (H)	1.3
UC 207 (D1)	T 207 (H)	1.7
UC 208 (D1)	T 208 (H)	2.3
UC 209 (D1)	T 209 (H)	2.4
UC 210 (D1)	T 210 (H)	2.5
UC 211 (D1)	T 211 (H)	3.8
UC 212 (D1)	T 212 (H)	4.7
UC 213 (D1)	T 213 (H)	7.0
UC 214 (D1)	T 214 (H)	7.3
UC 215 (D1)	T 215 (H)	7.7
UC 216 (D1)	T 216 (H)	8.4
UC 217 (D1)	T 217 (H)	11.0

PILLOW BLOCKS CAST HOUSINGS (SET SCREW TYPE)
SERIES UCUP 200

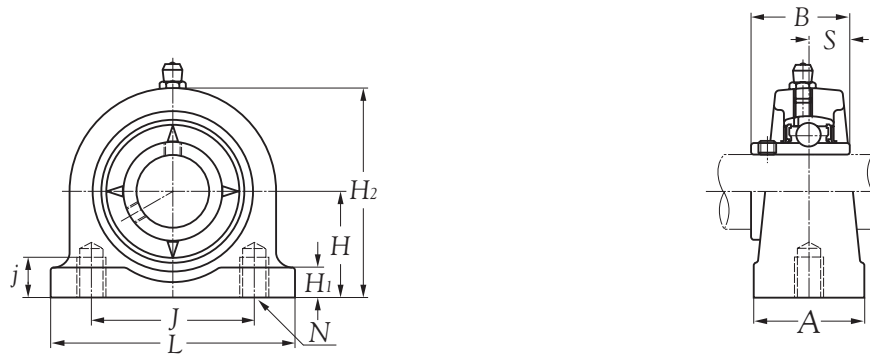

Shaft dia. mm	Unit number	Nominal dimensions									
		H	L	J	A	mm j	H1	H2	B	S	
12	UCUP 201 (H)	30.2	76	52	38	13	11	62	31.0	12.7	
15	UCUP 202 (H)	30.2	76	52	38	13	11	62	31.0	12.7	
17	UCUP 203 (H)	30.2	76	52	38	13	11	62	31.0	12.7	
20	UCUP 204 (H)	30.2	76	52	38	13	11	62	31.0	12.7	
25	UCUP 205 (H)	36.5	84	56	38	15	12	72	34.1	14.3	
30	UCUP 206 (H)	42.9	94	66	48	18	12	84	38.1	15.9	
35	UCUP 207 (H)	47.6	110	80	48	20	13	95	42.9	17.5	
40	UCUP 208 (H)	49.2	116	84	54	20	13	100	49.2	19.0	
45	UCUP 209 (H)	54.2	120	90	54	25	13	108	49.2	19.0	
50	UCUP 210 (H)	57.2	130	94	60	25	14	116	51.6	19.0	

PILLOW BLOCKS CAST HOUSINGS (SET SCREW TYPE)
SERIES UCUP 200

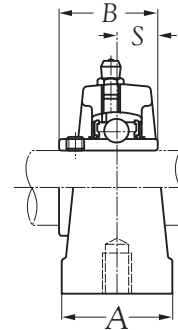
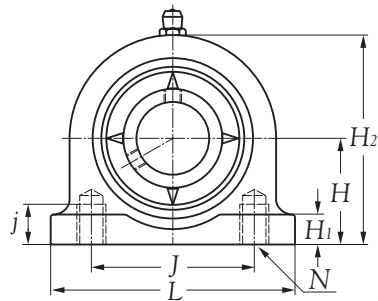

N	Bearing number	Housing number	Mass of unit
			kg
M10x1.5	UC 201 (D1)	UP 204 (H)	0.6
M10x1.5	UC 202 (D1)	UP 204 (H)	0.6
M10x1.5	UC 203 (D1)	UP 204 (H)	0.6
M10x1.5	UC 204 (D1)	UP 204 (H)	0.6
M10x1.5	UC 205 (D1)	UP 205 (H)	0.8
M14x2	UC 206 (D1)	UP 206 (H)	1.2
M14x2	UC 207 (D1)	UP 207 (H)	1.7
M14x2	UC 208 (D1)	UP 208 (H)	2.0
M14x2	UC 209 (D1)	UP 209 (H)	2.2
M16x2	UC 210 (D1)	UP 210 (H)	2.9

BALL BEARINGS (SET SCREW TYPE)
SERIES UC 200

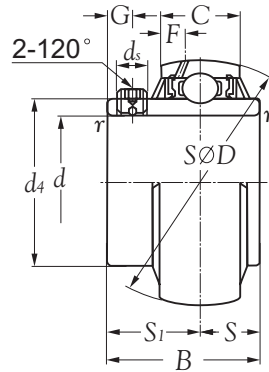

Shaft dia. mm	Unit number	Nominal dimensions											Basic load ratings		Mass kg
		d	D	B	C	r _s	S	S ₁	G	d _s	d ₄	F	N dynamic C _r	N static C _{0r}	
12	UC 201 (D1)	12	47	31.0	17	0.6	12.7	18.3	4.5	M5x0.8	29.6	4.7	12800	6650	0.21
15	UC 202 (D1)	15	47	31.0	17	0.6	12.7	18.3	4.5	M5x0.8	29.6	4.7	12800	6650	0.20
17	UC 203 (D1)	17	47	31.0	17	0.6	12.7	18.3	4.5	M5x0.8	29.6	4.7	12800	6650	0.18
20	UC 204 (D1)	20	47	31.0	17	1.0	12.7	18.3	4.5	M5x0.8	29.6	4.7	12800	6650	0.17
25	UC 205 (D1)	25	52	34.1	17	1.0	14.3	19.8	5.0	M5x0.8	33.9	4.5	14000	7850	0.20
30	UC 206 (D1)	30	62	38.1	19	1.0	15.9	22.2	5.0	M6x0.75	40.8	4.6	19500	11300	0.33
35	UC 207 (D1)	35	72	42.9	20	1.5	17.5	25.4	6.0	M6x0.75	46.8	4.6	25700	15300	0.49
40	UC 208 (D1)	40	80	49.2	21	1.5	19.0	30.2	8.0	M8x1	53.0	4.5	29100	17800	0.65
45	UC 209 (D1)	45	85	49.2	22	1.5	19.0	30.2	8.0	M8x1	57.5	4.9	32500	20400	0.70
50	UC 210 (D1)	50	90	51.6	24	1.5	19.0	32.6	9.0	M8x1	62.4	5.9	35000	23200	0.80
55	UC 211 (D1)	55	100	55.6	25	2.0	22.2	33.4	9.0	M8x1	69.0	6.0	43500	29200	1.08
60	UC 212 (D1)	60	110	65.1	27	2.0	25.4	39.7	10.0	M10x1.25	77.0	6.2	52500	36000	1.53
65	UC 213 (D1)	65	120	65.1	32	2.0	25.4	39.7	10.0	M10x1.25	82.5	8.7	57500	40000	1.85
70	UC 214 (D1)	70	125	74.6	33	2.0	30.2	44.4	12.0	M10x1.25	87.0	8.8	62000	44000	2.10
75	UC 215 (D1)	75	130	77.8	34	2.0	33.3	44.5	12.0	M10x1.25	93.0	9.0	66000	49500	2.35
80	UC 216 (D1)	80	140	82.6	35	2.5	33.3	49.3	12.0	M10x1.25	98.1	9.5	72500	53000	2.80
85	UC 217 (D1)	85	150	85.7	36	2.5	34.1	51.6	12.0	M12x1.5	106.4	10.1	83500	64000	3.37
90	UC 218 (D1)	90	160	96.0	37	2.5	39.7	56.3	12.0	M12x1.5	111.6	9.8	96000	71500	4.36

Note: It's applied to assemble with **NIKO** housings P, F, FL, FC, T and UP.

BALL BEARINGS (ECCENTRIC LOCKING COLLAR TYPE)
SERIES AEL 200

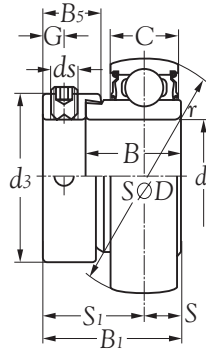

Shaft dia. mm	Unit number	Nominal dimensions											Basic load ratings		Mass kg	
		<i>d</i>	<i>D</i>	<i>B</i> ₁	<i>B</i>	<i>C</i>	<i>r</i> _s	<i>S</i>	<i>S</i> ₁	<i>G</i>	<i>d</i> _s	<i>d</i> ₃	<i>B</i> ₅	N dynamic <i>C</i> _r		N static <i>C</i> _{0r}
12	AEL201 (D1)	12	40	28.6	19.0	12	0.6	6.5	22.1	4.8	M6x0.75	29.0	13.6	9600	4600	0.12
15	AEL202 (D1)	15	40	28.6	19.0	12	0.6	6.5	22.1	4.8	M6x0.75	29.0	13.6	9600	4600	0.11
17	AEL203 (D1)	17	40	28.6	19.0	12	0.6	6.5	22.1	4.8	M6x0.75	29.0	13.6	9600	4600	0.10
20	AEL204 (D1)	20	47	31.0	21.5	14	1.0	7.5	23.5	4.8	M6x0.75	33.0	13.5	12800	6650	0.17
25	AEL205 (D1)	25	52	31.0	21.5	15	1.0	7.5	23.5	4.8	M6x0.75	38.0	13.5	14000	7850	0.20
30	AEL206 (D1)	30	62	35.7	23.8	16	1.0	9.0	26.7	6.0	M8x1	44.5	15.9	19500	11300	0.31
35	AEL207 (D1)	35	72	38.9	25.4	17	1.5	9.5	29.4	6.8	M10x1.25	55.5	17.5	25700	15300	0.49
40	AEL208 (D1)	40	80	43.7	30.2	18	1.5	11.0	32.7	6.8	M10x1.25	60.0	18.3	29100	17800	0.66

BALL BEARINGS (SET SCREW TYPE)
SERIES AS 200

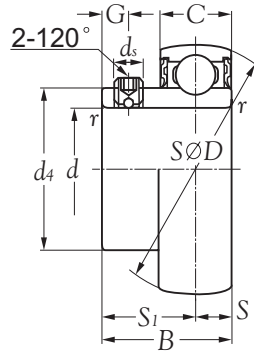

Shaft dia. mm	Unit number	Nominal dimensions										Basic load ratings		Mass kg
		d	D	B	C	r_s	S	S_1	G	d_s	d_4	dynamic C_r	static C_{or}	
12	AS 201 (D1)	12	40	22	12	0.6	6.0	16.0	4.2	M5x0.8	24.3	9600	4600	0.10
15	AS 202 (D1)	15	40	22	12	0.6	6.0	16.0	4.2	M5x0.8	24.3	9600	4600	0.09
17	AS 203 (D1)	17	40	22	12	0.6	6.0	16.0	4.2	M5x0.8	24.3	9600	4600	0.08
20	AS 204 (D1)	20	47	25	14	1.0	7.0	18.0	4.2	M5x0.8	29.6	12800	6650	0.13
25	AS 205 (D1)	25	52	27	15	1.0	7.5	19.5	5.0	M5x0.8	33.9	14000	7850	0.16
30	AS 206 (D1)	30	62	29	16	1.0	8.0	21.0	5.0	M6x0.75	40.8	19500	11300	0.25
35	AS 207 (D1)	35	72	34	17	1.5	8.5	25.5	6.0	M6x0.75	46.8	25700	15300	0.37
40	AS 208 (D1)	40	80	38	18	1.5	9.0	29.0	8.0	M8x1	53.0	29100	17800	0.50

**BALL BEARINGS (ADAPTER TYPE)
SERIES UK 200**

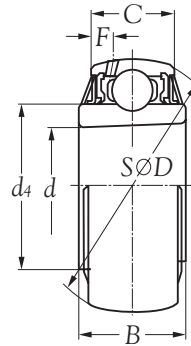
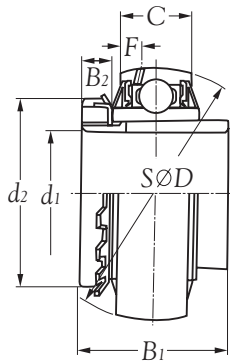

Taper 1:12

Shaft dia. mm	Unit number	Nominal dimensions										Basic load ratings		Mass kg
		mm										N		
		d	D	B	C	d_4	d_1	B_1	B_2	d_2	F	dynamic C_r	static C_{or}	
20	UK 205 (D1)	25	52	23	17	33.9	20	35	8	38	4.5	14000	7850	0.25
25	UK 206 (D1)	30	62	26	19	40.8	25	38	8	45	4.6	19500	11300	0.36
30	UK 207 (D1)	35	72	29	20	46.8	30	43	9	52	4.6	25700	15300	0.57
35	UK 208 (D1)	40	80	31	21	53.0	35	46	10	58	4.5	29100	17800	0.74
40	UK 209 (D1)	45	85	31	22	57.5	40	50	11	65	4.9	32500	20400	0.83
45	UK 210 (D1)	50	90	32	24	62.4	45	55	12	70	5.9	35000	23200	0.97
50	UK 211 (D1)	55	100	35	25	69.0	50	59	12	75	6.0	43500	29200	1.26
55	UK 212 (D1)	60	110	38	27	77.0	55	62	13	80	6.2	52500	36000	1.59
60	UK 213 (D1)	65	120	40	32	82.5	60	65	14	85	8.7	57500	40000	2.00
65	UK 215 (D1)	75	130	44	34	93.0	65	73	15	98	9.0	66000	49500	2.56
70	UK 216 (D1)	80	140	45	35	98.1	70	78	17	105	9.5	72500	53000	3.23



Bearing Units

Using applications

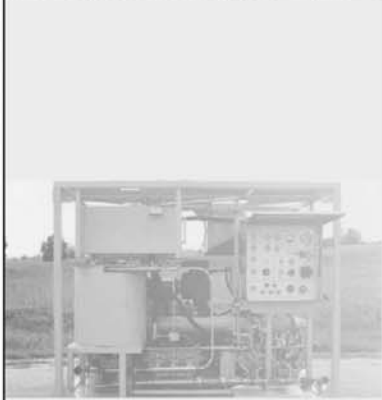

- Extruder gearbox
- Bevel gearbox
- Small electric motor
- Electric car motor
- Research vessel "M/V OCEAN Explorer"
- Concrete pipe production
- Jachmann bridge
- Tennis stadium
- Bascule bridge
- Belt conveyor system
- Analytical instrument
- Refraction unit
- Urology instrument
- Handling robot
- Lorry-mounted crane
- Plastic blow moulding machine
- Injection moulding machine
- Calender
- Cut-off valve
- Rodless pneumatic cylinder
- Radial piston motor
- Garden secateurs
- Hay tedding machine
- Automatic assembly machine
- Cabriolet
- Passenger car steering bearings
- Cross-cut and mitre-box saw
- Rail vehicle tilt system
- Tram
- Metro train
- Fitness training machine
- Roller or in-line skates
- Continuous casting machine
- Power saw
- Machining centre
- Front-operated lathe
- Deep hole drilling machine
- Sheetfed offset printing press
- All-purpose food slicer



NIPPON KODO AUTOMATION TECHNOLOGY CO. LTD.

[HTTP://WWW.NIPPONKODOBEARINGS.CO.JP](http://www.nipponkodobearings.co.jp)

HEADQUARTER:

ADDRESS: ROOM 205, GRANDEUR IMAZATO BLDG.

**NO. 1-4, 4-CHOME, IMAZATO,
NAGAKAKYO-CITY 617-0814,
KYOTO, JAPAN**

TEL: 81-75-959-0221

FAX: 81-75-959-0222

E-MAIL: NIKO@NIPPONKODOJAPAN.COM

CAT. NO. NIKO-BU 1/E-07