



SINCE 2002

NIKO®

PRECISION **B**ALL SCREWS



PRECISION BALL SCREWS

CATALOGUE

→ | **Note**

Dotted lines for note content.

1. NIKO Precision Ball Screws

NIKO applies stringent quality control standards on every production process. With proper lubrication and use, trouble-free operation for an extended period of time is possible.

Table Mean Travel Deviation ($\pm E$) and Travel Variation (e) (JIS B 1192)

Unit: μm

Accuracy Grade		C0		C1		C2		C3		C5		C7	C10
Thread length above	below	$\pm E$	e	$\pm E$	e	$\pm E$	e	$\pm E$	e	$\pm E$	e	e	e
		100	200	3	3	3.5	5	5	7	8	8	18	18
100	200	3.5	3	4.5	5	7	7	10	8	20	18		
200	315	4	3.5	6	5	8	7	12	8	23	18		
315	400	5	3.5	7	5	9	7	13	10	25	20		
400	500	6	4	8	5	10	7	15	10	27	20		
500	630	6	4	9	6	11	8	16	12	30	23		
630	800	7	5	10	7	13	9	18	13	35	25		
800	1000	8	6	11	8	15	10	21	15	40	27		
1000	1250	9	6	13	9	18	11	24	16	46	30		
1250	1600	11	7	15	10	21	13	29	18	54	35		
1600	2000			18	11	25	15	35	21	65	40		
2000	2500			22	13	30	18	41	24	77	46		
2500	3150			26	15	36	21	50	29	93	54		
3150	4000			30	18	44	25	60	35	115	65		
4000	5000					52	30	72	41	140	77		
5000	6300					65	36	90	50	170	93		
6300	8000							110	60	210	115		
8000	10000									260	140		
10000	12500									320	170		

Variation per 300mm (e_{300}) and Wobble Error ($e_{2\pi}$) (JIS B 1192)

Unit: μm

Accuracy Grade	C0	C1	C2	C3	C5	C7	C10
e_{300}	3.5	5	7	8	18	50	210
$e_{2\pi}$	2.5	4	5	6	8		

Specification Number

Model-number coding

SFU R 025 05 T4 D G C5 -600 P1 - B2 + N3 N3

<p>Nut type codes</p> <p>S S: Single nut D: Double nut</p> <p>F F: With flange C: Without flanges</p> <p>E: E nut H: H nut</p> <p>U Y: Y nut S: DIN nut I: I nut U: DIN nut K: K nut</p>												<p>Shaft Surface Treatment</p> <p>S: Standard B1: Black Oxidation N1: Hard Chrome Plating P: Phosphating N3: Nickel Plating N4: Raydent N5: Chrome Plating</p>
<p>Direction of helix</p> <p>R: Right L: Left</p>											<p>Nut Surface Treatment</p> <p>S: Standard B1: Black Oxidation N1: Hard Chrome Plating P: Phosphating N3: Nickel Plating N4: Raydent N5: Chrome Plating</p>	
<p>Shaft dia.(mm)</p>											<p>Number of Nut (Leave blank if only one nut is required) Ex: Install two nuts on a shaft B2</p>	
<p>Lead(mm)</p>										<p>Axial clearance and perload codes: P0, P1, P2, P3, P4</p>		
<p>No. of Turn(Circuits) of Turn x Row 卷数:T:1 A:1.8 B:2.8 C:3.8 D:4.8 Sample:(B2 = 2.5 x2)</p>										<p>Overall length of shaft(mm)</p>		
<p>Flange type</p> <p>N: Not cutting S: Single cutting D(U): Double cutting</p>										<p>Accuracy grade code (C0, C1, C2, C3, C5, C7, C10)</p> <p>G(P): Ground F(T): Rolled</p>		

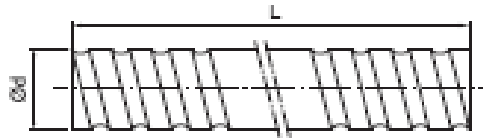

Fig 2.1.1 Screw Shaft Nominal Diameter

2-1 Nominal Model Code of Ball Screw

Table 2.1.1 Ground Ball Screw Specifications Ø4-32

Model No.			Accuracy Grade	Threading Direction	Number of Grooves	Standard Code of Shaft	Type of Nut
Ød	l	Da		R : Right L : Left			
4	1	0.800	C7, C5, C3	R	1	SCR00401	K
6	1	0.800	C7, C5, C3	R	1	SCR00601	K
8	1	0.800	C7, C5, C3	R/L	1	SCR00801	K
	2	1.200	C7, C5, C3	R/L	1	SCR00802	K
	2.5	1.200	C7, C5, C3	R	1	SCR0082.5	K, BSH
10	2	2.000	C7, C5, C3	R/L	1	SCR01002	K, BSH
	4	4.000	C7, C5, C3	R	1	SCR01004	K, BSH
12	2	1.200	C7, C5, C3	R/L	1	SCR01202	K
	4	2.500	C7, C5, C3	R	1	SCR01204	U, BSH
	5	2.500	C7, C5, C3	R	1	SCR01205-A	V, U, BSH, H, A
	10	2.500	C7, C5, C3	R	2	SCR01210-B	V
14	2	1.200	C7, C5, C3	R/L	1	SCR01402	K
	4	2.500	C7, C5, C3	R	1	SCR01404	BSH
15	10	3.175	C7, C5, C3	R	1	SCR01510	V
	20	3.175	C7, C5, C3	R	1	SCR01520	V
16	2	1.200	C7, C5, C3	R/L	1	SCR01602	K
	4	2.381	C7, C5, C3	R	1	SCR01604(N)	V, I, U, BSH
	5	3.175	C7, C5, C3	R/L	1	SCR01605	V, NI, NU, BSH
	10	3.175	C7, C5, C3	R/L	2	SCR01610	V, NI, NU, BSH
	16	2.778	C7, C5, C3	R	2	SCR01616	Y
20	32	2.778	C7, C5, C3	R	2	SCR01632	Y
	2	1.200	C7, C5, C3	R	1	SCR02002	K
	4	2.381	C7, C5, C3	R	1	SCR02004(N)	V, I, U
	5	3.175	C7, C5, C3	R/L	1	SCR02005	V, NI, NU, BSH, H, A
	10	3.969	C7, C5, C3	R	1	SCR02010	V
	20	3.175	C7, C5, C3	R	2	SCR02020	V, Y, H, A
25	40	3.175	C7, C5, C3	R	2	SCR02040	Y
	2	1.200	C7, C5, C3	R	1	SCR02502	K
	4	2.381	C7, C5, C3	R	1	SCR02504(N)	I, U
	5	3.175	C7, C5, C3	R/L	1	SCR02505	V, NI, NU, BSH, H, A
	6	3.969	C7, C5, C3	R	1	SCR02506	V, U
	8	4.762	C7, C5, C3	R	1	SCR02508	V, U
	10	4.762	C7, C5, C3	R/L	1	SCR02510-A	NI, NU, BSH
	10	6.350	C7, C5, C3	R	1	SCR02510-B	V
	25	3.969	C7, C5, C3	R	2	SCR02525	Y
32	50	3.969	C7, C5, C3	R	2	SCR02530	Y
	4	2.381	C7, C5, C3	R	1	SCR03204(N)	V, I, U
	5	3.175	C7, C5, C3	R/L	1	SCR03205	V, NI, NU, M, H, A
	6	3.969	C7, C5, C3	R	1	SCR03206	V, U
	8	4.762	C7, C5, C3	R	1	SCR03208	V, U
	10	6.350	C7, C5, C3	R/L	1	SCR03210	V, NI, NU
	20	6.350	C7, C5, C3	R	1	SCR03220	V
32	4.762	C7, C5, C3	R	2	SCR03232	Y	
	64	4.762	C7, C5, C3	R	2	SCR03264	Y

2-1 Nominal Model Code of Ball Screw

Table 2.1.2 Standard Specifications Ø40-80

Unit : mm

Model No.			Accuracy Grade	Threading Direction	Number of Grooves	Standard Code of Shaft	Type of Nut
Ød	l	Da		R : Right L : Left			
40	5	3.175	C7, C5, C3	R / L	1	SCR04005	V, NI, NU, H, A
	6	3.969	C7, C5, C3	R	1	SCR04006	V, NU
	8	4.762	C7, C5, C3	R	1	SCR04008	V, NU
	10	6.35	C7, C5, C3	R / L	1	SCR04010	V, NI, NU
	20	6.35	C7, C5, C3	R	2	SCR04020	V
	40	6.35	C7, C5, C3	R	2	SCR04040	Y
	80	6.35	C7, C5, C3	R	2	SCR04080	Y
50	5	3.175	C7, C5, C3	R	1	SCR05005	V, H, A
	10	6.35	C7, C5, C3	R / L	1	SCR05010	V, NI, NU
	20	9.525	C7, C5, C3	R	1	SCR05020	V
	50	7.938	C7, C5, C3	R	2	SCR05050	Y
	100	7.938	C7, C5, C3	R	2	SCR050100	Y
63	10	6.35	C7, C5, C3	R	1	SCR06310	V, NI, NU
	20	9.525	C7, C5, C3	R	1	SCR06320	V, NU
80	10	6.35	C7, C5, C3	R	1	SCR08010	V, NI, NU
	20	9.525	C7, C5, C3	R	1	SCR08020	V, U

Table 2.1.3 H, A-type Specifications Ø16-50

Unit : mm

Model No.			Accuracy Grade	Threading Direction	Number of Grooves	Type-H Code of Shaft	Type of Nut
Ød	l	Da		R : Right L : Left			
12	10	2.5	C7, C5, C3	R	1	SSR01210	H, A
16	5	2.778	C7, C5, C3	R	1	SSR01605	H, A
	10	2.778	C7, C5, C3	R	1	SSR01610	H, A
	16	2.778	C7, C5, C3	R	1	SSR01616	H, A
	20	2.778	C7, C5, C3	R	1	SSR01620	H, A
20	10	3.175	C7, C5, C3	R	1	SSR02010	H, A
25	10	3.175	C7, C5, C3	R	1	SSR02510	H, A
	25	3.175	C7, C5, C3	R	1	SSR02525	H, A
32	10	3.969	C7, C5, C3	R	1	SSR03210	H, A
	20	3.969	C7, C5, C3	R	1	SSR03220	H, A
	32	6.35	C7, C5, C3	R	1	SSR03232	H, A
40	10	6.35	C7, C5, C3	R	1	SSR04010	H, A
	20	6.35	C7, C5, C3	R	1	SSR04020	H, A
	40	6.35	C7, C5, C3	R	1	SSR04040	H, A
50	10	6.35	C7, C5, C3	R	1	SSR05010	H, A
	20	6.35	C7, C5, C3	R	1	SSR05020	H, A
	50	6.35	C7, C5, C3	R	1	SSR05050	H, A

 ※The information is for specifications, if customized products are needed please contact **NIKO**.

2-2 Precision Ground Ball Screw Series

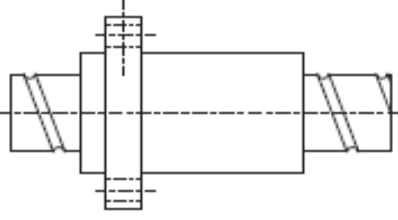
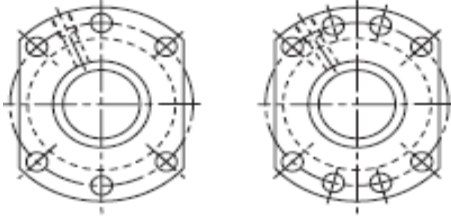
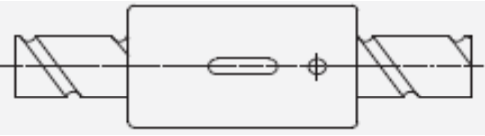
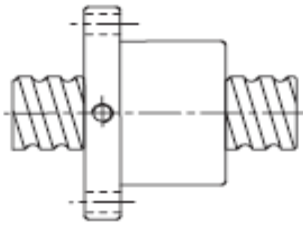
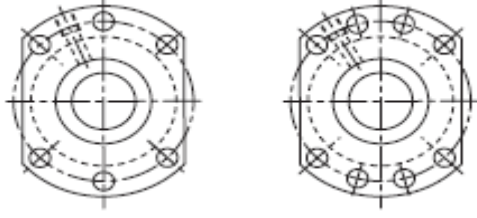
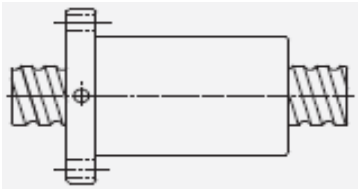
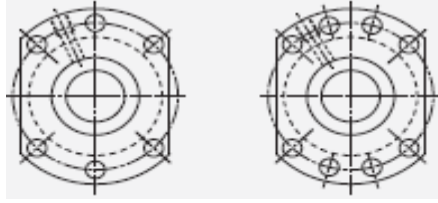

2-2-1 NIKO Nut of Precision Ground Ball Screw Type

	Nut Type	Flange Type
<p>H/A (A solution for slide table/High Speed/Strong dust-proof type)</p>	<p>SFH/SFA (DIN) C44, 45</p> 	 <p>d ≤ 32 d ≥ 40</p>
<p>CNH (A solution for slide table)</p>	<p>SCNH C46</p> 	<p>No-Flange</p>
<p>□ (Strong dust-proof type)</p>	<p>SFU (DIN) C47</p> 	 <p>d ≤ 32 d ≥ 40</p>
<p>□ (OFF set double nut)</p>	<p>DFU (DIN) C48</p> 	

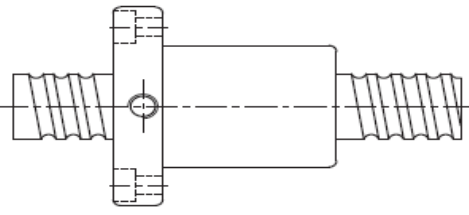
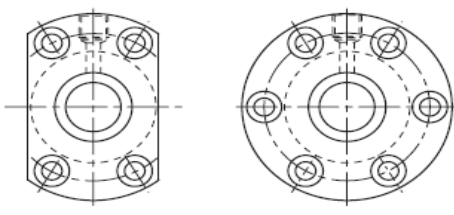
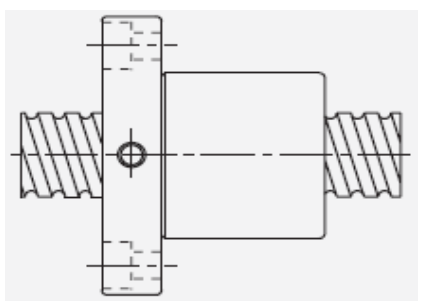
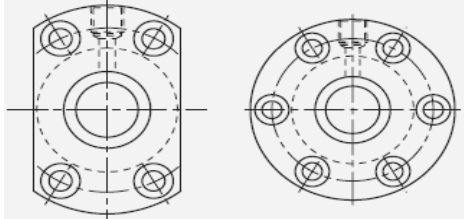
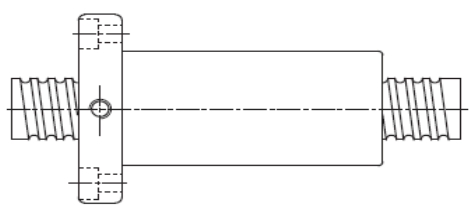
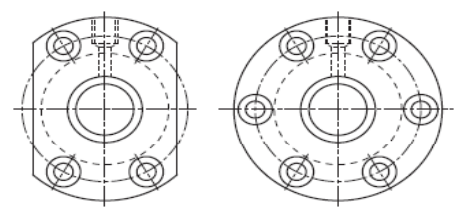
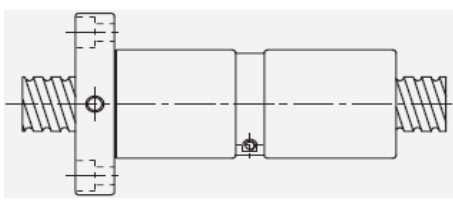
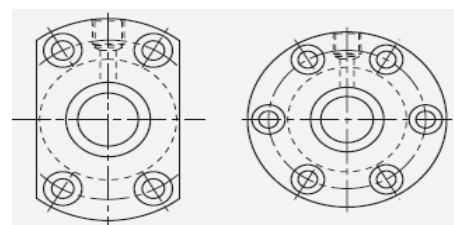
2-2 Precision Ground Ball Screw Series

		Nut Type	Flange Type
I (Strong dust-proof type)	SFI  C49		
M (Design for Milling)	SFM  C49		
I (OFF set double nut)	DFI  C50		
M (Design for Milling)	DFM  C50		

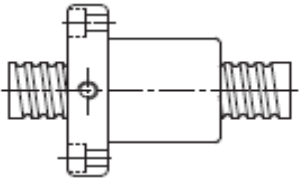
2-2 Precision Ground Ball Screw Series

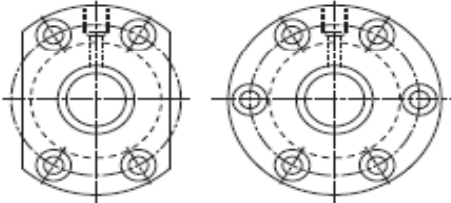
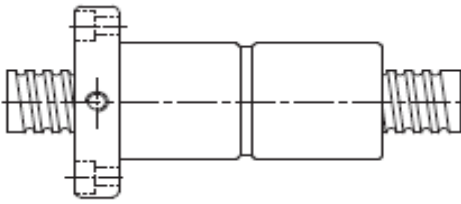
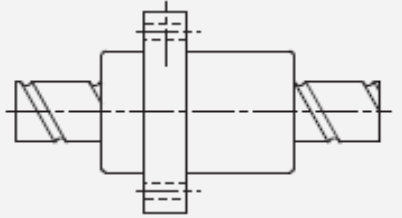
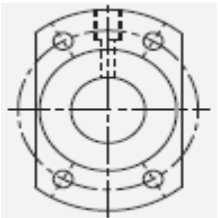
Nut Type		Flange Type
<p>V</p> <p>(High Load External Circulation type)</p>	<p>SFV</p>  <p>C51</p>	
<p>OFV</p> <p>(OFF set double nut)</p>	 <p>C52</p>	
<p>V</p> <p>(High Load External Circulation type)</p>	<p>DFV</p>  <p>C52</p>	
<p>Y</p> <p>(High DM-N Rating)</p>	 <p>C53</p>	

2-2 Precision Ground Ball Screw Series

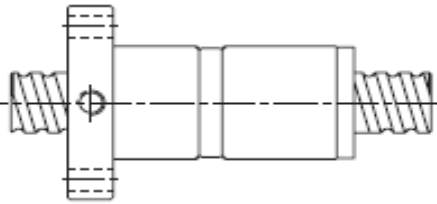
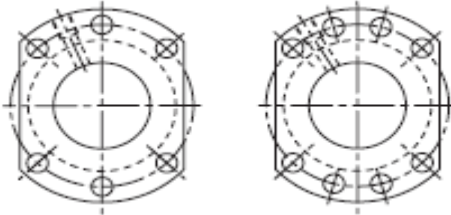
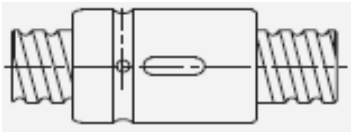
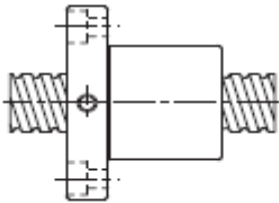
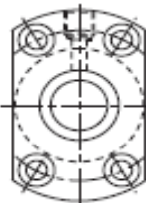
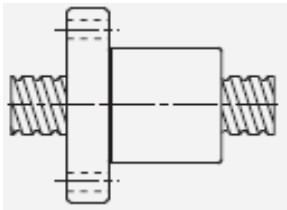
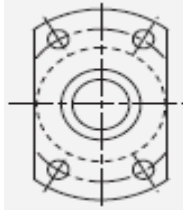
		Nut Type	Flange Type
<p>S (High Speed / Low Noise type)</p>	<p>DFS (DIN)</p>  <p>C54</p>	 <p>Model No. ≤3232 Model No. ≥4005</p>	
	<p>SCI</p>  <p>C55</p>	<p>No-Flange</p>	
<p>K (Miniature type)</p>	<p>SFK</p>  <p>C56</p>	 <p>(SFK 01004) (SFK 02002) (SFK 02502)</p>	
	<p>SFK</p>  <p>C56</p>		

2-2 Precision Ground Ball Screw Series

Nut Type		Flange Type
BSH		No-Flange
XSV (Design for factory automation)		

※The information is for specifications, if customized products is are needed please contact **NIKO**.

Table 2.2.1 Preload Chart

Preload	I, U, M-type	H, A-type	Y-type	V-type	BSH-type	K-type
P0						
P1	√	√	√	√	√	√
P2	√	√	√	√	√	
P3	√	√	√	√	√	
P4				√		

■ 2-3-1 Rolled Screws

Rolled screws are made through thread roller. Generally rolled screw has a smoother operation while lowering friction and backlash. Therefore, it gradually replaced the traditional ACME screws and trapezoidal screws. Moreover, rolled screws can eliminate axial play by preloading nut with a cost effective pricing compare to ground screw.

■ 2-3-2 The Features of NIKO Rolled Ball Screw

(1) Lead Accuracy Up to Grade C5

C7 and C10 Screws have been Standardized. C5 on request.

(2) Precision Ground Ball Nut

High Precision Ball Nut are interchangeable between ground and rolled screws.

(3) Available to ship separately

Ball screw and ball nuts can be shipped separated ensure shortest delivery time. The ball nuts are standardized with P0 preloaded, preload value can be adjusted through reballing.

■ 2-3-3 Nominal Model Code of Rolled Ball Screws

Nominal Model Code of Shaft

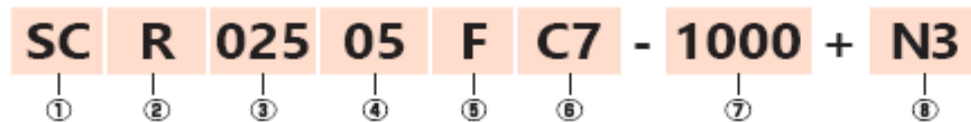

①	④	⑦
Type of Screw Shaft	Lead	Overall Length of Shaft
SC : standard SS : For H, NH type nut	Unit : mm	Unit : mm
②	⑤	⑧
Threading Direction	Product Code	Shaft Surface Treatment
R : Right L : Left	F : Rolled	□ : Standard B1 : Black Oxidation N1 : Hard Chrome Plating P : Phosphating N3 : Nickel Plating N4 : Raydent N5 : Chrome Plating
③	⑥	
Nominal Diameter	Accuracy Grade	
Unit : mm	C5, C7, C10	

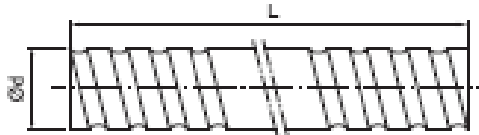

Fig 2.3.1 Screw Shaft Nominal Diameter

Table 2.3.1 Rolled Ball Screw Specifications Ø6~32

Unit : mm

Model No.			Accuracy Grade	Threading Direction	Number of Grooves	Standard Code of Shaft	Type of Nut	Overall Length of Shaft	
Ød	l	Da		R : Right L : Left					
6	1	0.8	C10, C7	R	1	SCR00601	K	1000	
8	1	0.8	C10, C7, C5	R	1	SCR00801	K	1000	
	2	1.2	C10, C7, C5	R	1	SCR00802	K		
10	2.5	1.2	C10, C7, C5	R	1	SCR0082.5	K, BSH	3000	
	2	1.2	C10, C7, C5	R	1	SCR01002	K, BSH		
12	4	2.0	C10, C7, C5	R	1	SCR01004	K, BSH	3000	
	2	1.2	C10, C7, C5	R	1	SCR01202	K		
14	4	2.5	C10, C7, C5	R	1	SCR01204	U, BSH		3000
	5	2.5	C10, C7, C5	R	1	SCR01205-A	V, U, BSH, H, A		
16	10	2.5	C10, C7, C5	R	2	SCR01210-B	V		3000
	20	2.5	C10, C7	R	4	SCR01220	Y		
18	2	1.2	C10, C7, C5	R	1	SCR01402	K	1800	
	4	2.5	C10, C7	R	1	SCR01404	BSH	3000	
20	4	2.381	C10, C7, C5	R	1	SCR01604(N)	V, I, U, BSH	3000	
	5	3.175	C10, C7, C5	R/L	1	SCR01605	V, NI, NU, BSH		
	10	3.175	C10, C7, C5	R	2	SCR01610	V, NI, NU, BSH		
	16	2.778	C10, C7, C5	R	4	SCR01616	Y		
	32	2.778	C10, C7	R	8	SCR01632	Y		
25	4	2.381	C10, C7, C5	R	1	SCR02004(N)	V, I, U	3000	
	5	3.175	C10, C7, C5	R/L	1	SCR02005	V, NI, NU, BSH, H, A		
	20	3.175	C10, C7, C5	R	4	SCR02020	V, Y, H, A		
	40	3.175	C10, C7	R	8	SCR02040	Y		
30	4	2.381	C10, C7	R	1	SCR02504(N)	I, U	6000	
	5	3.175	C10, C7, C5	R/L	1	SCR02505	V, NI, NU, BSH, H, A		
	10	4.762	C10, C7, C5	R	1	SCR02510-A	NI, NU, BSH		
	10	6.350	C10, C7, C5	R	1	SCR02510-B	V		
	25	3.969	C10, C7, C5	R	4	SCR02525	Y		
	50	3.969	C10, C7	R	8	SCR02550	Y		
32	4	2.381	C10, C7, C5	R	1	SCR03204(N)	V, I, U	6000	
	5	3.175	C10, C7, C5	R/L	1	SCR03205	V, NI, NU, M, H, A		
	10	6.350	C10, C7, C5	R/L	1	SCR03210	V, NI, NU		
	32	4.762	C10, C7	R	4	SCR03232	Y		
	64	4.762	C10, C7	R	8	SCR03264	Y		

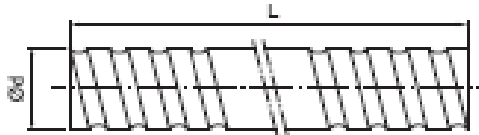

Fig 2.3.1 Screw Shaft Nominal Diameter

Table2.3.2 Standard Specifications Ø40~80

Unit : mm

Model No.			Accuracy Grade	Threading Direction	Number of Grooves	Standard Code of Shaft	Type of Nut	Overall Length of Shaft
Ød	l	Da		R : Right L : Left				
40	5	3.2	C10, C7, C5	R/L	1	SCR04005	V, NI, NU, H, A	6000
	10	6.4	C10, C7	R/L	1	SCR04010	V, NI, NU	
	20	6.4	C10, C7	R	2	SCR04020	V	
	40	6.4	C10, C7	R	4	SCR04040	Y	
	80	6.4	C10, C7	R	8	SCR04080	Y	
50 [●]	5	3.2	C10, C7, C5	R	1	SCR05005	V, H, A	6000
	10	6.4	C10, C7, C5	R/L	1	SCR05010	V, NI, NU	
	20	9.5	C10, C7	R	1	SCR05020	V	
	50	7.9	C10, C7	R	4	SCR05050	Y	
	100	7.9	C10, C7	R	8	SCR050100	Y	
63 [●]	10	6.4	C10, C7, C5	R	1	SCR06310	V, NI, NU	7000
	20	9.5	C10, C7	R	1	SCR06320	V, NU	
80 [●]	10	6.4	C10, C7, C5	R	1	SCR08010	V, NI, NU	7000
	20	9.5	C10, C7	R	1	SCR08020	V, U	

Table2.3.3 H, A-Type Specifications Ø16~50

Unit : mm

Model No.			Accuracy Grade	Threading Direction	Number of Grooves	Standard Code of Shaft	Type of Nut	Overall Length of Shaft
Ød	l	Da		R : Right L : Left				
12	10	2.5	C10, C7, C5	R	2	SSR01210	H, A	3000
16	5	2.8	C10, C7, C5	R	1	SSR01605	H, A	3000
	10	2.8	C10, C7, C5	R	2	SSR01610	H, A	
	16	2.8	C10, C7, C5	R	4	SSR01616	H, A	
	20	2.8	C10, C7, C5	R	4	SSR01620	H, A	
20	10	3.2	C10, C7, C5	R	2	SSR02010	H, A	3000
25	10	3.2	C10, C7, C5	R	2	SSR02510	H, A	6000
	25	3.2	C10, C7	R	4	SSR02525	H, A	
32	10	4.0	C10, C7, C5	R	1	SSR03210	H, A	6000
	20	4.0	C10, C7	R	2	SSR03220	H, A	
	32	4.0	C10, C7	R	4	SSR03232	H, A	
40	10	6.4	C10, C7	R	1	SSR04010	H, A	6000
	20	6.4	C10, C7, C5	R	2	SSR04020	H, A	
	40	6.4	C10, C7	R	4	SSR04040	H, A	
50 [●]	10	6.4	C10, C7	R	1	SSR05010	H, A	6000
	20	6.4	C10, C7	R	2	SSR05020	H, A	
	50	6.4	C10, C7	R	4	SSR05050	H, A	

※The information is for standard production, if required accuracy grade C5 or other needs, please contact NIKO.

※Please contact NIKO MOTION if the marked types (●) are required.

2-4 Rolled Ball Screw Series

Nominal Model Code of Nut

G
SFU
R
025
05
T4
D
 +
 N3

1
2
3
4
5
6
7
8

①

Product Code

②

Nominal Model

S	S : Single nut
	D : Double nut
F	F : With flange
	C : Without flange
U	I : I type nut
	U : U type nut
	H : H type nut
	A : A type nut
	H : H nut (A solution for slide table)
	Y : Y type nut
	V : V type nut
	U : DIN nut
	M : M type nut
	K : K type nut

③

Threading Direction

R : Right
L : Left

④

Nominal Diameter

Unit : mm

⑤

Lead

Unit : mm

⑥

Number of Turns (Turn Row)

Turn : T : 1
A : 1.5 (or 1.7/1.8)
B : 2.5/2.8
C : 3.5
D : 4.8
ex : (2.5 × 2 = B2)

⑦

Flange Type

N : Not cutting
S : Single cutting
D : Double cutting

⑧

Nut Surface Treatment

S : Standard
B1 : Black Oxidation
N1 : Hard Chrome Plating
P : Phosphating
N3 : Nickel Plating
N4 : Raydent
N5 : Chrome Plating

■ 2-3-4 Preload of Rolled Ball Screw

The standard preloading for Rolled Ball Screw is P0. If P1 preloading is required, please contact NIKO.

Table 2.3.4 Rolled screw accuracy

Unit : μm

Accuracy Grade	C5 (DIN)	C7	C10
e300	23	50	210

2-4-1 Nut of Rolled Ball Screw Type

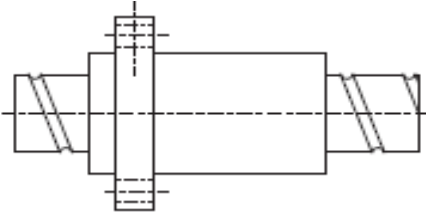
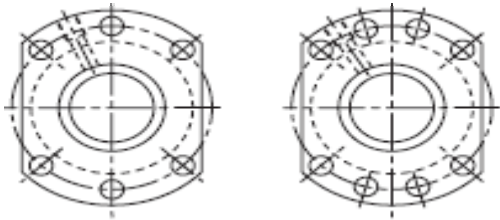
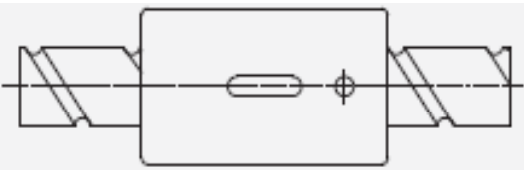
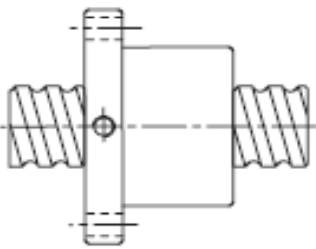
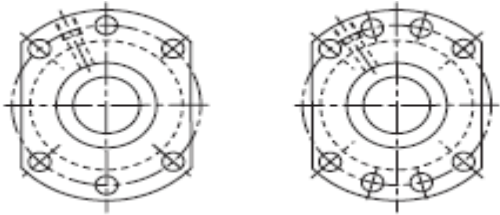
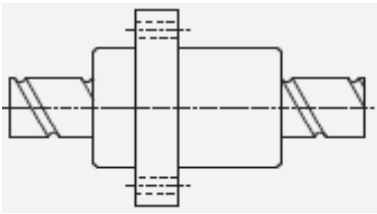
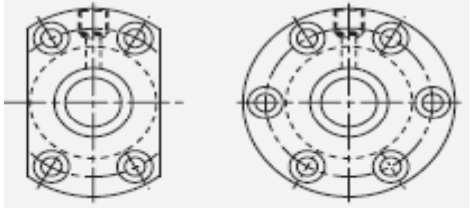
Nut Type		Flange Type	
<p>NH/H/A (A solution for slide table/High Speed/Strong dust-proof type)</p>	<p>SFNH/SFH/SFA (DIN) C70, 71</p> 	 <p>d ≤ 32 d ≥ 40</p>	
<p>CNH (A solution for slide table)</p>	<p>SCNH C72</p> 	<p>No-Flange</p>	
<p>▷ (Strong dust-proof type)</p>	<p>SFU (DIN) C73</p> 	 <p>d ≤ 32 d ≥ 40</p>	
<p>┆ (Strong dust-proof type)</p>	<p>SFI C74</p> 		

2-4 Rolled Ball Screw Series

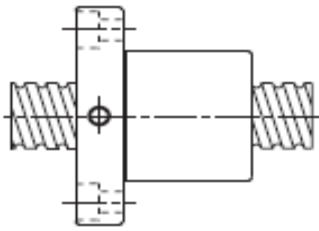
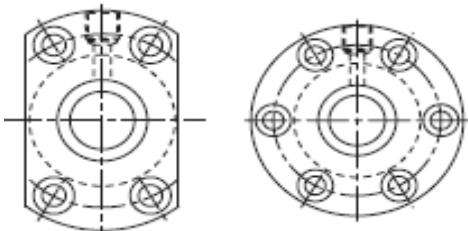
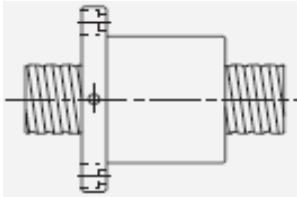
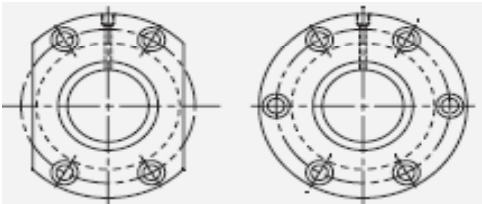
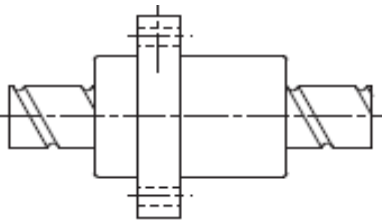
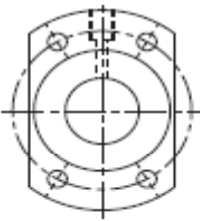
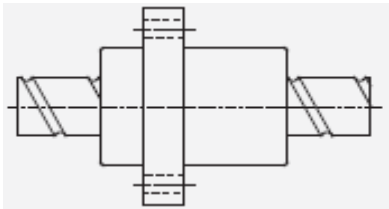
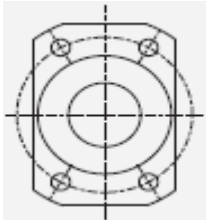
		Nut Type	Flange Type
M	(Design for Milling)	<p>SFM</p>  <p>C74</p>	
V	(High Load External Circulation type)	 <p>C75</p>	
Y	(High DM-N Rating)	 <p>C76</p>	
XSY	(Miniature type)	 <p>C77</p>	

2-4 Rolled Ball Screw Series

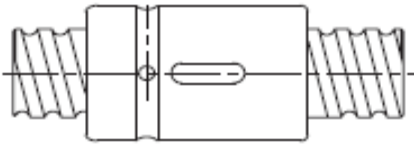
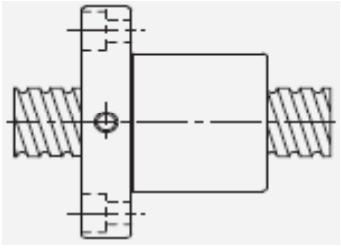
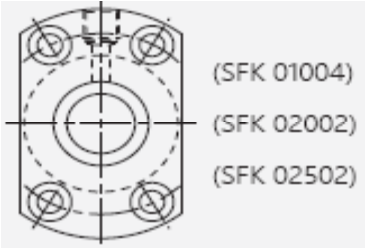
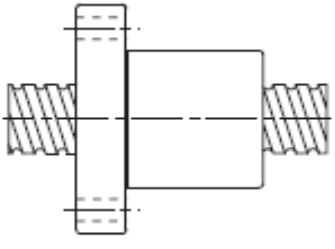
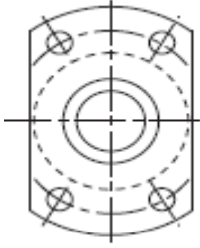
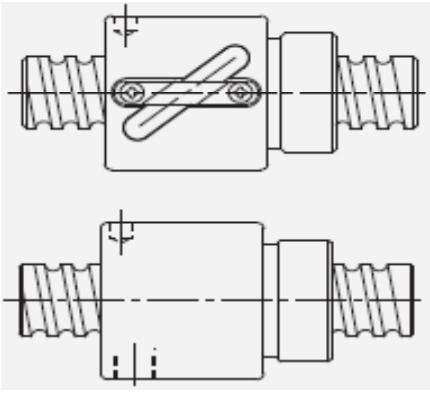
Nut Type		Flange Type
I (Standard)	SCI  C78	No-Flange
	K (Miniature type)	 C79  <ul style="list-style-type: none"> (SFK 01004) (SFK 02002) (SFK 02502)
	SFK  C79	
BSH	BSH  C80	No-Flange

SFK Series Specifications

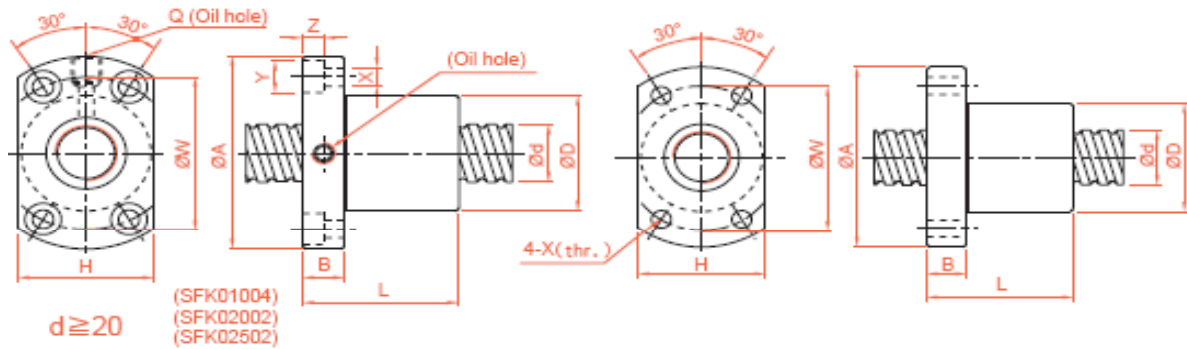

Model No.	d	I	Da	Dimension											Load Rating		K kgf/um
				D	A	B	L	W	H	X	Y	Z	Q	n	Ca (kgf)	Coa (kgf)	
SFKR00401	4	1	0.8	10	20	3	12	15	14	2.9	-	-	-	1x2	64	97	5
SFKR00601	6	1	0.8	12	24	3.5	15	18	16	3.4	-	-	-	1x3	111	224	9
SFKR00801☆	8	1	0.8	14	27	4	16	21	18	3.4	-	-	-	1x4	161	403	14
SFKR00802☆		2	1.2	14	27	4	16	21	18	3.4	-	-	-	1x3	222	458	13
SFKR0082.5		2.5	1.2	16	29	4	26	23	20	3.4	-	-	-	1x3	221	457	13
SFKR01002☆	10	2	1.2	18	35	5	28	27	22	4.5	-	-	-	1x3	243	569	15
SFKR01004		4	2	26	46	10	34	36	28	4.5	8	4.5	M6	1x3	468	905	17
SFKR01204	12	2	1.2	20	37	5	28	29	24	4.5	-	-	-	1x4	334	906	22
SFKR01205		4	2.5	24	40	6	28	32	25	3.5	-	-	-	1x3	454	772	
SFKR01202		5	2.5	22	37	8	28	39	24	4.5	-	-	-	1x3	675	1316	
SFKR01402	14	2	1.2	21	40	6	23	31	26	5.5	-	-	-	1x4	354	1053	24
SFKR01602	16	2	1.2	25	43	10	40	35	29	5.5	-	-	M6	1x4	373	1200	26
SFKR02002	20	2	1.2	50	80	15	55	65	68	6.5	10.5	6	M6	1x6	581	2284	48
SFKR02502	25	2	1.2	50	80	13	43	65	68	6.5	10.5	6	M6	1x5	540	2381	46

※ ☆ Left helix available

SCI Series Specifications

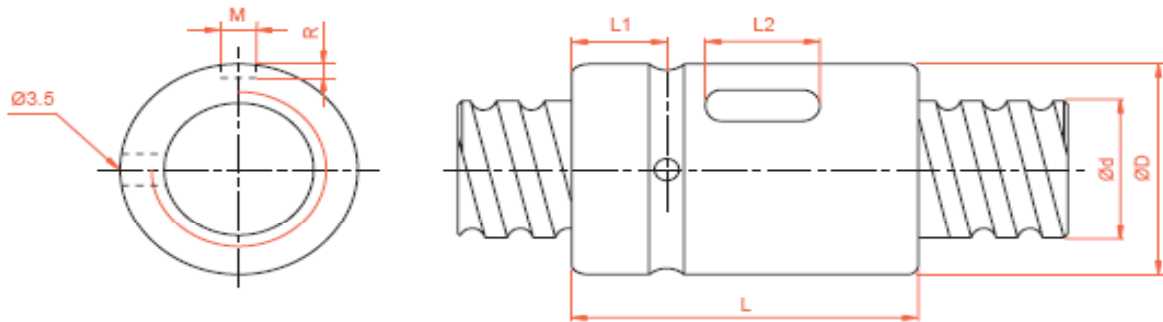

Model No.	d	I	Da	Dimension							Load Rating		K kgf/um
				D	L	L1	L2	M	R	n	Ca (kgf)	Coa (kgf)	
SCI 01604-4	16	4	2.381	30	40	9	15	3	1.5	1x4	973	2406	32
SCI 01605-4☆		5	3.175	30	45	9	20	5	3	1x4	1380	3052	33
SCI 02004-4	20	4	2.381	34	40	9	15	3	2	1x4	1066	2987	37
SCI 02005-4☆		5	3.175	34	45	9	20	5	3	1x4	1551	3875	39
SCI 02504-4	25	4	2.381	40	40	9	15	3	2	1x4	1180	3795	43
SCI 02505-4☆		5	3.175	40	45	9	20	5	3	1x4	1724	4904	45
SCI 02510-4		10	4.762	46	85	13	30	5	3	1x4	2954	7295	51
SCI 03205-4☆	32	5	3.175	46	45	9	20	5	3	1x4	1922	6343	52
SCI 03210-4		10	6.350	54	85	13	30	5	3	1x4	4805	12208	62
SCI 04005-4	40	5	3.175	56	45	9	20	5	3	1x4	2110	7988	59
SCI 04010-4		10	6.350	62	85	13	30	5	3	1x4	5399	15500	72
SCI 05010-4	50	10	6.350	72	85	13	30	5	3	1x4	6004	19614	83
SCI 06310-4	63	10	6.350	85	85	13	30	6	3.5	1x4	6719	25358	95
SCI 08010-4	80	10	6.350	105	85	13	30	8	4.5	1x4	7346	31953	109

※ ☆ Left helix available

SFSR (DIN 69051 FORM B) Series Specifications

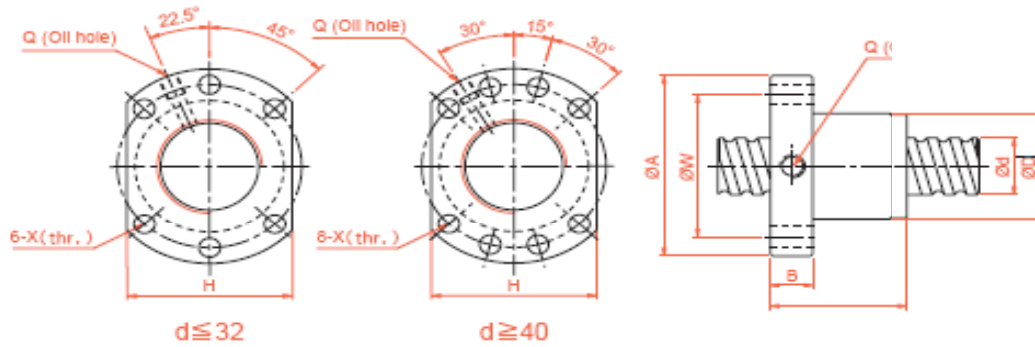

Model No.	d	I	Da	Dimension									Load Rating		K kgf/um
				D	A	B	L	W	H	X	Q	n	Ca (kgf)	Coa (kgf)	
SFSR01205-2.8	12	5	2.500	24	40	10	31	32	30	4.5	M6	2.8x1	661	1316	
SFSR01210-2.8		10	2.500	24	40	10	48.5	32	30	4.5	M6	2.8x1	642	1287	
SFSR01605-3.8	15	5	2.778	28	48	10	38	38	40	5.5	M6	3.8x1	1112	2507	
SFSR01610-2.8		10	2.778	28	48	10	47	38	40	5.5	M6	2.8x1	839	1821	
SFSR01616-1.8		16	2.778	28	48	10	45	38	40	5.5	M6	1.8x1	552	1137	
SFSR01616-2.8		16	2.778	28	48	10	61	38	40	5.5	M6	2.8x1	808	1769	
SFSR01620-1.8		20	2.778	28	48	10	57	38	40	5.5	M6	1.8x1	554	1170	
SFSR02005-3.8	20	5	3.175	36	58	10	40	47	44	6.6	M6	3.8x1	1484	3681	
SFSR02010-3.8		10	3.175	36	58	10	60	47	44	6.6	M6	3.8x1	1516	3833	
SFSR02020-1.8		20	3.175	36	58	10	57	47	44	6.6	M6	1.8x1	764	1758	
SFSR02020-2.8		20	3.175	36	58	10	77	47	44	6.6	M6	2.8x1	1118	2734	
SFSR02505-3.8	25	5	3.175	40	62	10	40	47	44	6.6	M6	3.8x1	1650	4658	
SFSR02510-3.8		10	3.175	40	62	12	65	51	48	6.6	M6	3.8x1	1638	4633	
SFSR02520-2.8		20	3.969	40	62	12	72	51	48	6.6	M6	2.8x1	1206	2695	
SFSR02525-1.8		25	3.175	40	62	12	70	51	48	6.6	M6	1.8x1	843	2199	
SFSR02525-2.8		25	3.175	40	62	12	95	51	48	6.6	M6	2.8x1	1232	3421	
SFSR03205-3.8	32	5	3.175	50	80	12	42	65	62	9.0	M6	3.8x1	1839	6026	
SFSR03210-3.8	31	10	3.969	50	80	13	62	65	62	9.0	M6	3.8x1	2460	7255	
SFSR03220-2.8		20	3.969	50	80	12	80	65	62	9.0	M6	2.8x1	1907	5482	
SFSR03232-1.8		32	3.969	50	80	13	84	65	62	9.0	M6	1.8x1	1257	3426	
SFSR03232-2.8		32	3.969	50	80	13	116	65	62	9.0	M6	2.8x1	1838	2329	
SFSR04005-3.8	40	5	3.175	63	93	15	45	78	70	9.0	M8	3.8x1	2018	7589	
SFSR04010-3.8	38	10	6.350	63	93	14	63	78	70	9.0	M8	3.8x1	5035	13943	
SFSR04020-2.8		20	6.350	63	93	14	82	78	70	9.0	M8	2.8x1	3959	10715	
SFSR04040-1.8		40	6.350	63	93	15	105	78	70	9.0	M8	1.8x1	2585	6648	
SFSR04040-2.8		40	6.350	63	93	15	145	78	70	9.0	M8	2.8x1	3780	10341	
SFSR05005-3.8	50	5	3.175	75	110	15	45	93	85	11.0	M8	3.8x1	2207	9542	
SFSR05010-3.8	48	10	6.350	75	110	18	68	93	85	11.0	M8	3.8x1	5638	17852	
SFSR05020-3.8		20	6.350	75	110	18	108	93	85	11.0	M8	3.8x1	5749	18485	
SFSR05050-1.8		50	6.350	75	110	18	125	93	85	11.0	M8	1.8x1	2946	8749	
SFSR05050-2.8		50	6.350	75	110	18	175	93	85	11.0	M8	2.8x1	4308	13610	

DFS (DIN 69051 FORM B) Series Specifications

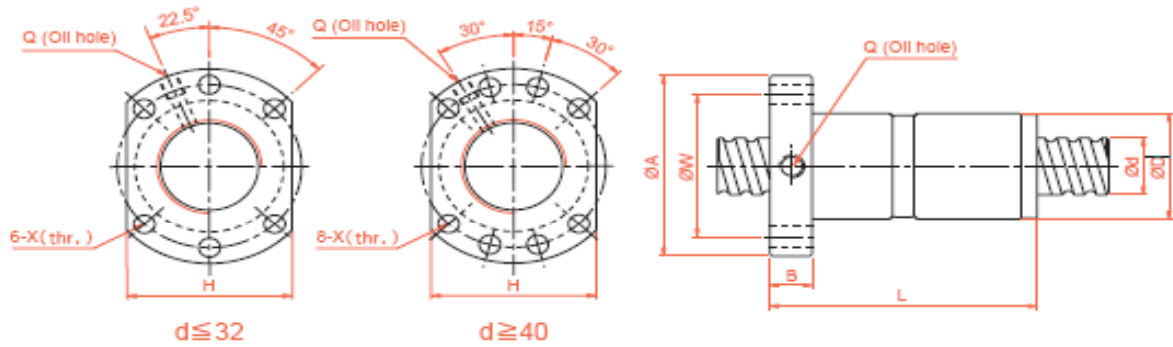

Model No.	d	I	Da	Dimension									Load Rating		K kgf/um
				D	A	B	L	W	H	X	Q	n	Ca (kgf)	Coa (kgf)	
DFSR01605-3.8	15	5	2.778	28	48	10	73	38	40	5.5	M6	3.8x1	1112	2507	41
DFSR01610-2.8		10	2.778	28	48	10	97	38	40	5.5	M6	2.8x1	839	1821	31
DFSR02005-3.8	20	5	3.175	36	58	10	75	47	44	6.6	M6	3.8x1	1484	3681	50
DFSR02010-3.8		10	3.175	36	58	10	120	47	44	6.6	M6	3.8x1	1516	3833	53
DFSR02505-3.8	25	5	3.175	40	62	10	75	51	48	6.6	M6	3.8x1	1650	4658	59
DFSR02510-3.8		10	3.175	40	62	12	122	51	48	6.6	M6	3.8x1	1638	4633	61
DFSR03205-3.8	32	5	3.175	50	80	12	82	65	62	9.0	M6	3.8x1	1839	6026	71
DFSR03210-3.8		10	3.969	50	80	13	122	65	62	9.0	M6	3.8x1	2460	7255	75
DFSR03220-2.8	31	20	3.969	50	80	12	160	65	62	9.0	M6	2.8x1	1907	5482	58
DFSR04005-3.8		40	5	3.175	63	93	15	85	78	70	9.0	M8	3.8x1	2018	7589
DFSR04010-3.8	38	10	6.350	63	93	14	123	78	70	9.0	M8	3.8x1	5035	13943	91
DFSR04020-2.8		20	6.350	63	93	14	162	78	70	9.0	M8	2.8x1	3959	10715	73
DFSR05005-3.8	50	5	3.175	75	110	15	85	93	85	11.0	M8	3.8x1	2207	9542	96
DFSR05010-3.8		10	6.350	75	110	18	138	93	85	11.0	M8	3.8x1	5638	17852	109
DFSR05020-3.8	48	20	6.350	75	110	18	218	93	85	11.0	M8	3.8x1	5749	18485	116

SFY Series Specifications

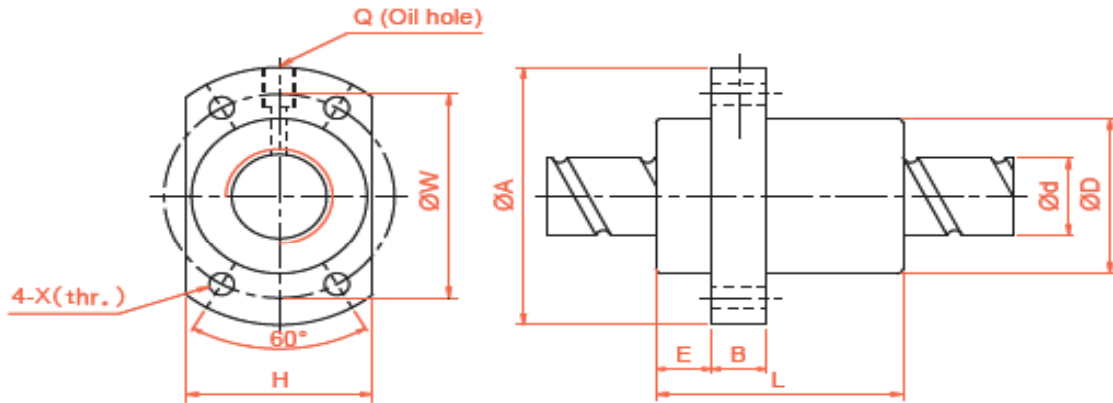

Large Lead Model No.	d	I	Da	Dimension										Load Rating		K kgf/um
				D	A	E	B	L	W	H	X	Q	n	Ca (kgf)	Coa (kgf)	
SFYR01616-3.6	16	16	2.778	32	53	10	10	45	42	34.0	4.5	M6	1.8x2	1073	2551	31
SFYR02020-3.6	20	20	3.175	39	62	13	10	52	50	41.0	5.5	M6	1.8x2	1387	3515	37
SFYR02040-1.6	40	40	3.175	39	62	13	10	48	50	41.0	5.5	M6	0.8x2	653	1597	15
SFYR02550-1.6	50	50	3.969	47	74	15	15	58	60	49.0	6.6	M6	0.8x2	976	2495	19
SFYR02525-3.6	25	25	3.969	47	74	15	12	64	60	49.0	6.6	M6	1.8x2	2074	5494	
SFYR03232-3.6	32	32	4.762	58	92	17	12	78	74	60.0	9.0	M6	1.8x2	3021	8690	58
SFYR04040-3.6	40	40	6.350	73	114	20	15	99	93	75.0	11.0	M6	1.8x2	4831	14062	70
SFYR05050-3.6	50	50	7.938	90	135	22	20	117	112	92.0	14.0	M6	1.8x2	7220	21974	86

SFE Series Specifications

Large Lead Model No.	d	I	Da	Dimension										Load Rating		K kgf/um
				D	A	E	B	L	W	H	X	Q	n	Ca (kgf)	Coa (kgf)	
SFE01616-3.6	16	16	2.778	32	53	10	10	45	42	34.0	4.5	M6	1.8x2	1073	2551	31
SFE02020-3.6	20	20	3.175	39	62	13	10	52	50	41.0	5.5	M6	1.8x2	1387	3515	37
SFE02525-3.6	25	25	3.969	47	74	15	12	64	60	49.0	6.6	M6	1.8x2	2074	5494	
SFE03232-3.6	32	32	4.762	58	92	17	12	78	74	60.0	9.0	M6	1.8x2	3021	8690	58
SFE04040-3.6	40	40	6.350	73	114	20	15	99	93	75.0	11.0	M6	1.8x2	4831	14062	70
SFE05050-3.6	50	50	7.938	90	135	22	20	117	112	92.0	14.0	M6	1.8x2	7220	21974	86

SFI Series Specifications

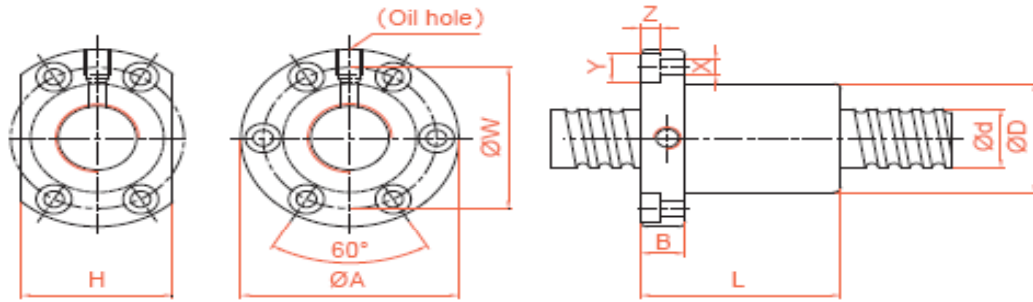

Model No.	d	I	Da	Dimension											Load Rating		K kgf/um
				D	A	B	L	W	H	X	Y	Z	Q	n	Ca (kgf)	Coa (kgf)	
SFIRO1605-4☆	16	5	3.175	30	49	10	45	39	34	4.5	8	4.5	M6	1x4	888	1525	
SFIRO1610-3☆		10	3.175	34	58	10	57	45	34	5.5	9.5	5.5	M6	1x3	716	1232	
SFIRO2005-4☆	20	5	3.175	34	57	11	51	45	40	5.5	9.5	5.5	M6	1x4	999	1994	
SFIRO2505-4☆	25	5	3.175	40	63	11	51	51	46	5.5	9.5	5.5	M8	1x4	1119	2581	
SFIRO2510-4☆		10	4.762	46	72	12	80	58	52	6.5	11	6.5	M6	1x4	1903	3695	
SFIRO3205-4☆	32	5	3.175	46	72	12	52	58	52	6.5	11	6.5	M8	1x4	1264	3402	
SFIRO3210-4☆		10	6.35	54	88	15	85	70	62	9	14	8.5	M8	1x4	3092	6101	
SFIRO4005-4	40	5	3.175	56	90	15	55	72	64	9	14	8.5	M8	1x4	1407	4341	
SFIRO4010-4		10	6.35	62	104	18	88	82	70	11	17.5	11	M8	1x4	3480	7779	
SFIRO5010-4	50	10	6.35	72	114	18	88	92	82	11	17.5	11	M8	1x4	3898	10325	
SFIRO6310-4	63	10	6.35	85	131	22	93	107	95	14	20	13	M8	1x4	4410	13611	
SFIRO8010-4	80	10	6.35	105	150	22	93	127	115	14	20	13	M8	1x4	4900	17366	

※ ☆ Left helix available

DFI Series Specifications

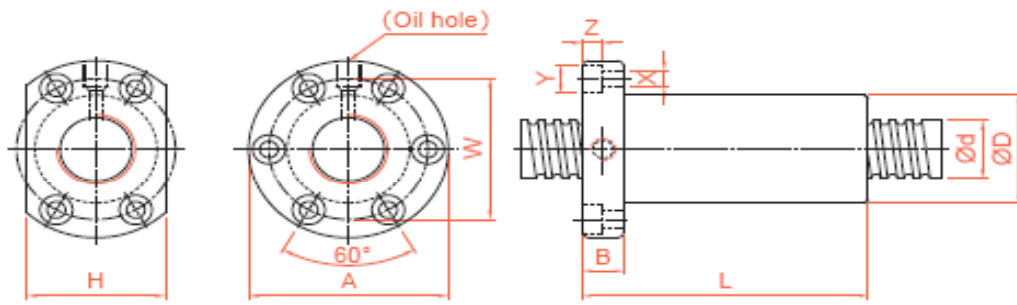

Model No.	d	I	Da	Dimension											Load Rating		K kgf/um
				D	A	B	L	W	H	X	Y	Z	Q	n	Ca (kgf)	Coa (kgf)	
DFIR01605-4 ☆	16	5	3.175	30	49	10	75	39	34	4.5	8	4.5	M6	1x4	888	1525	
DFIR02005-4 ☆	20	5	3.175	34	57	11	85	45	40	5.5	9.5	5.5	M6	1x4	999	1994	
DFIR02505-4 ☆	25	5	3.175	40	63	11	86	51	46	5.5	9.5	5.5	M8	1x4	1119	2581	
DFIR02510-4 ☆		10	4.762	46	72	12	130	58	52	6.5	11	6.5	M6	1x4	1903	3695	
DFIR03205-4 ☆	32	5	3.175	46	72	12	87	58	52	6.5	11	6.5	M8	1x4	1264	3402	
DFIR03210-4		10	6.35	54	88	15	145	70	62	9	14	8.5	M8	1x4	3092	6101	
DFIR04005-4	40	5	3.175	56	90	15	90	72	64	9	14	8.5	M8	1x4	1407	4341	
DFIR04010-4		10	6.35	62	104	18	148	82	70	11	17.5	11	M8	1x4	3480	7779	
DFIR05010-4	50	10	6.35	72	114	18	148	92	82	11	17.5	11	M8	1x4	3898	10325	
DFIR06310-4	63	10	6.35	85	131	22	153	107	95	14	20	13	M8	1x4	4410	13611	
DFIR08010-4	80	10	6.35	105	150	22	153	127	115	14	20	13	M8	1x4	4900	17366	

※ ☆ Left helix available

SFU (DIN 69051 FORM B) Series Specifications

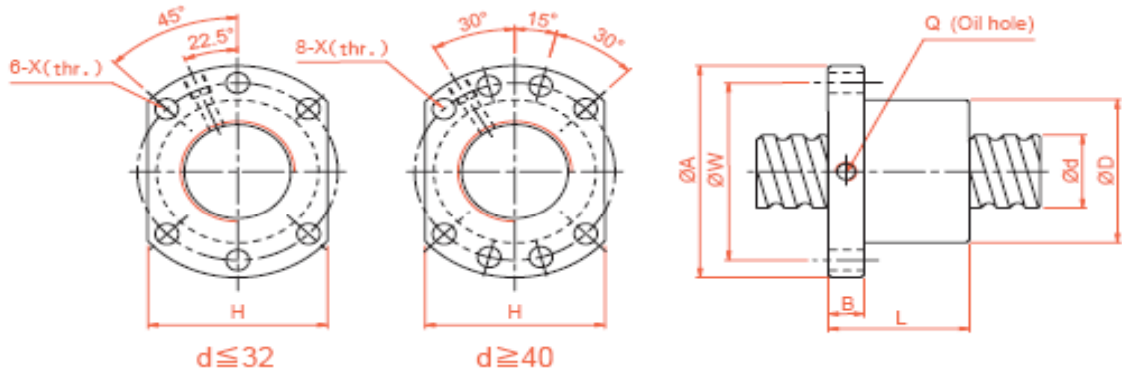

Model No.	d	l	Da	Dimension									Load Rating		K kgf/um
				D	A	B	L	W	H	X	Q	n	Ca (kgf)	Coa (kgf)	
SFUR01204-3☆	12	4	2.500	24	40	10	40	32	30	4.5	-	1x3	451	709	
SFUR01604-3	16	4	2.381	28	48	10	36	38	40	5.5	M6	1x3	488	940	
SFUR01605-3☆		5	3.175	28	48	10	42	38	40	5.5	M6	1x3	666	1143	
SFUR01605-4☆		5	3.175	28	48	10	50	38	40	5.5	M6	1x4	888	1525	
SFUR01610-3☆		10	3.175	28	48	10	57	38	40	5.5	M6	1x3	716	1232	
SFUR02004-3	20	4	2.381	36	58	10	42	47	44	6.6	M6	1x3	541	1187	
SFUR02005-3☆		5	3.175	36	58	10	42	47	44	6.6	M6	1x3	749	1495	
SFUR02005-4☆		5	3.175	36	58	10	51	47	44	6.6	M6	1x4	999	1994	
SFUR02504-3	25	4	2.381	40	62	10	42	51	48	6.6	M6	1x3	605	1534	
SFUR02505-3☆		5	3.175	40	62	10	42	51	48	6.6	M6	1x3	839	1935	
SFUR02505-4☆		5	3.175	40	62	10	51	51	48	6.6	M6	1x4	1119	2581	
SFUR02510-3☆		10	4.762	40	62	10	70	51	48	6.6	M6	1x3	1427	2771	
SFUR02510-4☆		10	4.762	40	62	12	85	51	48	6.6	M6	1x4	1903	3695	
SFUR03205-4	32	5	3.175	50	80	12	52	65	62	9	M6	1x4	1264	3402	
SFUR03210-3		10	6.35	50	80	12	74	65	62	9	M6	1x3	2319	4575	
SFUR03210-4		10	6.35	50	80	12	90	65	62	9	M6	1x4	3092	6101	
SFUR04005-4	40	5	3.175	63	93	14	55	78	70	9	M8	1x4	1407	4341	
SFUR04010-3		10	6.35	63	93	14	71	78	70	9	M8	1x3	2610	5834	
SFUR04010-4		10	6.35	63	93	14	93	78	70	9	M8	1x4	3480	7779	
SFUR05010-4	50	10	6.35	75	110	16	93	93	85	11	M8	1x4	3898	10325	
SFUR06310-4	63	10	6.35	90	125	18	93	108	95	11	M8	1x4	4401	13611	
SFUR06320-4		20	9.525	95	135	20	149	115	100	13.5	M8	1x4	7404	19008	
SFUR08010-4	80	10	6.35	105	145	20	98	125	110	13.5	M8	1x4	4900	17366	
SFUR08020-4		20	9.525	125	165	25	154	145	130	13.5	M8	1x4	8403	25345	

※ ☆ Left helix available

DFU (DIN 69051 FORM B) Series Specifications

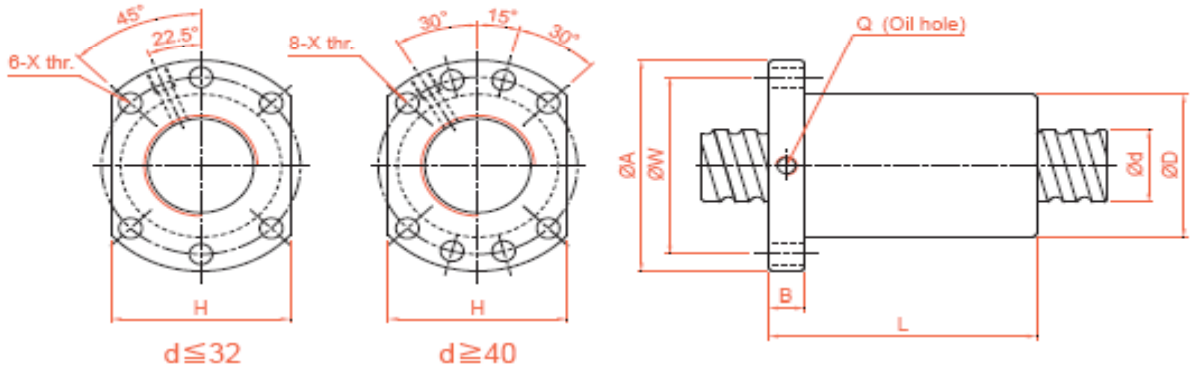

Model No.	d	l	Da	Dimension									Load Rating		K kgf/um
				D	A	B	L	W	H	X	Q	n	Ca (kgf)	Coa (kgf)	
DFUR01604-3	16	4	2.381	28	48	10	80	38	40	5.5	M6	1x3	488	940	
DFUR01605-4☆		5	3.175	28	48	10	100	38	40	5.5	M6	1x4	885	1525	
DFUR01610-3☆		10	3.175	28	48	10	118	38	40	5.5	M6	1x3	716	1232	
DFUR02004-3	20	4	2.381	36	58	10	80	47	44	6.6	M6	1x3	541	1187	
DFUR02005-4☆		5	3.175	36	58	10	101	47	44	6.6	M6	1x4	999	1994	
DFUR02504-3	25	4	2.381	40	62	10	80	51	48	6.6	M6	1x3	605	1534	
DFUR02505-4☆		5	3.175	40	62	10	101	51	48	6.6	M6	1x4	1119	2581	
DFUR02510-4☆		10	4.762	40	62	12	145	51	48	6.6	M6	1x4	1927	2771	
DFUR03205-4☆	32	5	3.175	50	80	12	102	65	62	9	M6	1x4	1264	3402	
DFUR03210-4		10	6.35	50	80	12	162	65	62	9	M6	1x4	3092	6101	
DFUR04005-4	40	5	3.175	63	93	14	105	78	70	9	M8	1x4	1407	4341	
DFUR04010-4		10	6.35	63	93	14	165	78	70	9	M8	1x4	3480	7979	
DFUR05010-4	50	10	6.35	75	110	16	171	93	85	11	M8	1x4	3898	10325	
DFUR06310-4	63	10	6.35	90	125	18	182	108	95	11	M8	1x4	4401	13611	
DFUR06320-4		20	9.525	95	135	20	290	115	100	13.5	M8	1x4	7404	19008	
DFUR08010-4	80	10	6.35	105	145	20	182	125	110	13.5	M8	1x4	4900	17366	
DFUR08020-4		20	9.525	125	165	25	295	145	130	13.5	M8	1x4	8403	25345	

※ ☆ Left helix available

SCNH Series Specifications

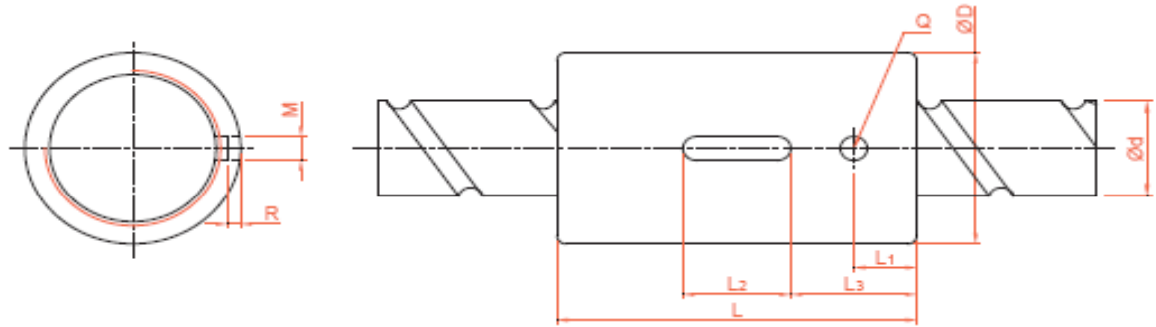

Model No.	d	l	Da	Dimension									Load Rating		K kgf/um
				D	L	L1	L2	L3	M	R	Q	n	Ca (kgf)	Coa (kgf)	
SCNH01205-4.8	12	5	2.500	24	40	7	12	14	3	1.5	3	4.8x1	1011	2105	34
SCNH01210-2.8		10	2.500	24	45	8	15	15	3	1.5	3	2.8x1	642	1287	19
SCNH01210-1.8		10	2.500	24	40	11	12	14	3	1.5	3	1.8x1	439	827	33
SCNH01605-5.8	15	5	2.778	28	45	7	20	13	5	3.0	3	5.8x1	1599	3827	49
SCNH01610-2.8		10	2.778	28	45	7	20	13	5	3.0	3	2.8x1	839	1821	23
SCNH01616-1.8		16	2.778	28	45	7	20	13	5	3.0	3	1.8x1	552	1137	18
SCNH01620-1.8		20	2.778	28	58	10	20	19	5	3.0	3	1.8x1	554	1170	14
SCNH02005-5.8	20	5	3.175	36	47	8	20	14	5	3.0	3	5.8x1	2134	5619	60
SCNH02010-3.8		10	3.175	36	55	8	20	18	5	3.0	3	3.8x1	1516	3833	40
SCNH02020-1.8		20	3.175	36	55	8	20	18	5	3.0	3	1.8x1	764	1758	19

SFH (DIN 69051 FORM B) Series Specifications

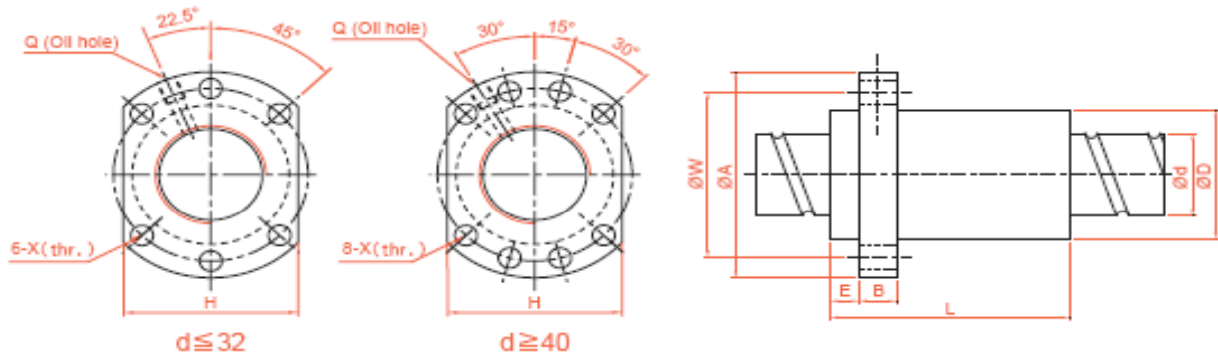

Model No.	d	l	Da	Dimension										Load Rating		K kgf/um
				D	A	E	B	L	W	H	X	Q	n	Ca (kgf)	Coa (kgf)	
SFH01205-2.8 [☆]	12	5	2.500	24	40	5	10	30	32	30	4.5	-	2.8x1	661	1316	19
SFH01210-2.8 [☆]		10	2.500	24	40	5	10	45	32	30	4.5	-	2.8x1	642	1287	19
SFH01605-3.8 [☆]	15	5	2.778	28	48	5	10	37	38	40	5.5	M6	3.8x1	1112	2507	30
SFH01610-2.8 [☆]		10	2.778	28	48	5	10	45	38	40	5.5	M6	2.8x1	839	1821	23
SFH01616-1.8 [☆]		16	2.778	28	48	5	10	45	38	40	5.5	M6	1.8x1	552	1137	14
SFH01616-2.8 [☆]		16	2.778	28	48	5	10	61	38	40	5.5	M6	2.8x1	808	1769	22
SFH01620-1.8 [☆]		20	2.778	28	48	7	10	58	38	40	5.5	M6	1.8x1	554	1170	14
SFH02005-3.8 [☆]	20	5	3.175	36	58	7	10	37	47	44	6.6	M6	3.8x1	1484	3681	37
SFH02010-3.8 [☆]		10	3.175	36	58	7	10	55	47	44	6.6	M6	3.8x1	1516	3833	40
SFH02020-1.8 [☆]		20	3.175	36	58	7	10	54	47	44	6.6	M6	1.8x1	764	1758	19
SFH02020-2.8 [☆]		20	3.175	36	58	7	10	74	47	44	6.6	M6	2.8x1	1118	2734	29
SFH02505-3.8 [☆]		5	3.175	40	62	7	10	37	51	48	6.6	M6	3.8x1	1650	4658	43
SFH02510-3.8 [☆]	25	10	3.175	40	62	7	12	55	51	48	6.6	M6	3.8x1	1638	4633	45
SFH02525-1.8 [☆]		25	3.175	40	62	7	12	64	51	48	6.6	M6	1.8x1	843	2199	22
SFH02525-2.8 [☆]		25	3.175	40	62	7	12	89	51	48	6.6	M6	2.8x1	1232	3421	34
SFH03205-3.8	32	5	3.175	50	80	9	12	37	65	62	9	M6	3.8x1	1839	6026	51
SFH03210-3.8	31	10	3.969	50	80	9	12	57	65	62	9	M6	3.8x1	2460	7255	55
SFH03220-2.8		20	3.969	50	80	9	12	76	65	62	9	M6	2.8x1	1907	5482	43
SFH03232-1.8		32	3.969	50	80	9	12	80	65	62	9	M6	1.8x1	1257	3426	27
SFH03232-2.8		32	3.969	50	80	9	12	112	65	62	9	M6	2.8x1	1838	5329	42
SFH04005-3.8	40	5	3.175	63	93	9	15	42	78	70	9	M8	3.8x1	2018	7589	60
SFH04010-3.8	38	10	6.35	63	93	9	14	60	78	70	9	M8	3.8x1	5035	13943	67
SFH04020-2.8		20	6.35	63	93	9	14	80	78	70	9	M8	2.8x1	3959	10715	54
SFH04040-1.8		40	6.35	63	93	9	14	98	78	70	9	M8	1.8x1	2585	6648	34
SFH04040-2.8		40	6.35	63	93	9	14	138	78	70	9	M8	2.8x1	3780	10341	52
SFH05005-3.8	50	5	3.175	75	110	10.5	15	42	93	85	11	M8	3.8x1	2207	9542	68
SFH05010-3.8	48	10	6.35	75	110	10.5	18	60	93	85	11	M8	3.8x1	5638	17852	79
SFH05020-3.8		20	6.35	75	110	10.5	18	100	93	85	11	M8	3.8x1	5749	18485	87
SFH05050-1.8		50	6.35	75	110	10.5	18	120	93	85	11	M8	1.8x1	2946	8749	42
SFH05050-2.8		50	6.35	75	110	10.5	18	170	93	85	11	M8	2.8x1	4308	13610	65

SFA Series Specifications

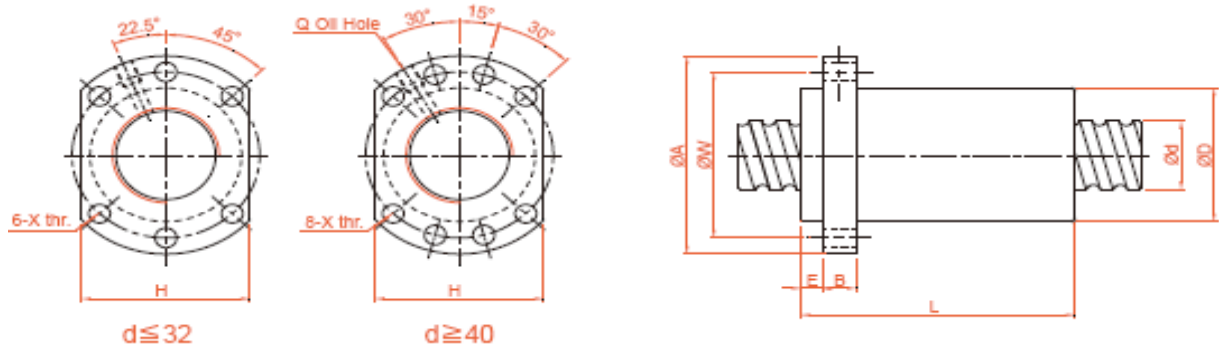

Model No.	d	l	Da	Dimension										Load Rating		K kgf/um
				D	A	E	B	L	W	H	X	Q	n	Ca (kgf)	Coa (kgf)	
SFA1205-2.8 [☆]	12	5	2.500	24	40	5	10	30	32	30	4.5	2.8×1	661	1316	19	-
SFA1210-2.8 [☆]		10	2.500	24	40	5	10	42	32	30	4.5	2.8×1	642	1287	19	-
SFA1605-3.8 [☆]	15	5	2.778	28	48	5	10	31	38	40	5.5	M6	3.8×1	1112	2507	30
SFA1610-2.8 [☆]		10	2.778	28	48	5	10	42	38	40	5.5	M6	2.8×1	839	1821	23
SFA1616-1.8 [☆]		16	2.778	28	48	5	10	43	38	40	5.5	M6	1.8×1	552	1137	14
SFA1616-2.8 [☆]		16	2.778	28	48	5	10	59	38	40	5.5	M6	2.8×1	808	1769	22
SFA1620-1.8 [☆]		20	2.778	28	48	5	10	50	38	40	5.5	M6	1.8×1	554	1170	14
SFA1630-1.8 [☆]	20	30	2.778	28	48	7	10	70	38	40	5.5	M6	1.8×1	534	1195	14
SFA2005-3.8 [☆]		5	3.175	36	58	7	10	33	47	44	6.6	M6	3.8×1	1484	3681	37
SFA2010-3.8 [☆]		10	3.175	36	58	7	10	52	47	44	6.6	M6	3.8×1	1516	3833	40
SFA2020-1.8 [☆]		20	3.175	36	58	7	10	52	47	44	6.6	M6	1.8×1	764	1758	19
SFA2020-2.8 [☆]		20	3.175	36	58	7	10	72	47	44	6.6	M6	2.8×1	1118	2734	29
SFA2505-3.8 [☆]	25	5	3.175	40	62	7	10	33	51	48	6.6	M6	3.8×1	1650	4658	43
SFA2510-3.8 [☆]		10	3.175	40	62	7	12	52	51	48	6.6	M6	3.8×1	1638	4633	45
SFA2525-1.8 [☆]		25	3.175	40	62	7	12	60	51	48	6.6	M6	1.8×1	843	2199	22
SFA2525-2.8 [☆]		25	3.175	40	62	7	12	85	51	48	6.6	M6	2.8×1	1232	3421	34
SFA3205-3.8	32	5	3.175	50	80	9	12	35	65	62	9	M6	3.8×1	1839	6026	51
SFA3210-3.8	31	10	3.969	50	80	9	12	53	65	62	9	M6	3.8×1	2460	7255	55
SFA3220-2.8		20	3.969	50	80	9	12	72	65	62	9	M6	2.8×1	1907	5482	43
SFA3232-1.8		32	3.969	50	80	9	12	78	65	62	9	M6	1.8×1	1257	3426	27
SFA3232-2.8		32	3.969	50	80	9	12	110	65	62	9	M6	2.8×1	1838	5329	42
SFA4005-3.8	40	5	3.175	63	93	9	14	39	78	70	9	M8	3.8×1	2018	7589	60
SFA4010-3.8	38	10	6.35	63	93	9	14	57	78	70	9	M8	3.8×1	5035	13943	67
SFA4020-2.8		20	6.35	63	93	9	14	78	78	70	9	M8	2.8×1	3959	10715	54
SFA4040-1.8		40	6.35	63	93	9	14	96	78	70	9	M8	1.8×1	2585	6648	34
SFA4040-2.8		40	6.35	63	93	9	14	136	78	70	9	M8	2.8×1	3780	10341	52
SFA5005-3.8	50	5	3.175	75	110	10.5	15	42	93	85	11	M8	3.8×1	2207	9542	68
SFA5010-3.8	48	10	6.35	75	110	10.5	18	57	93	85	11	M8	3.8×1	5638	17852	79
SFA5020-3.8		20	6.35	75	110	10.5	18	98	93	85	11	M8	3.8×1	5749	18485	87
SFA5050-1.8		50	6.35	75	110	10.5	18	117	93	85	11	M8	1.8×1	2946	8749	42
SFA5050-2.8		50	6.350	75	110	11	18	167	93	85	11.0	M8	2.8×1	4308	13610	65

BSHR Series Specifications

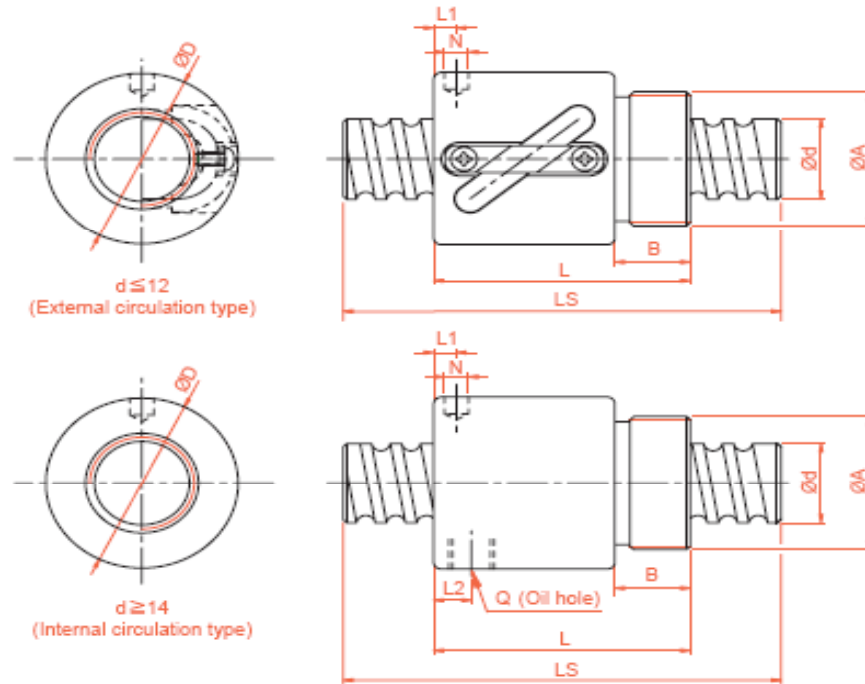

Model No.	d	I	Da	Dimension									Load Rating		K kgf/um
				D	A	B	L	L1	N	L2	Q	n	Ca (kgf)	Coa (kgf)	
BSHR0082.5-2.5	8	2.5	1.2	17.5	M15x1P	7.5	23.5	10	3	-	-	2.5x1	189	381	11
BSHR01002-3.5	10	2	1.2	19.5	M17x1P	7.5	22	3	3.2	-	-	3.5x1	277	664	17
BSHR01004-2.5		4	2	25	M20x1P	10	34	3	3	-	-	2.5x1	400	754	14
BSHR01204-3.5	12	4	2.5	25.5	M20x1P	10	34	13	3	-	-	3.5x1	804	1649	23
BSHR01205-3.5		5	2.5	25.5	M20x1P	10	39	16.25	3	-	-	3.5x1	801	1644	24
BSHR01404-3	14	4	2.5	32.1	M25x1.5P	10	35	11	3	-	-	1x3	748	1609	26
BSHR01604-3	16	4	2.381	29	M22x1.5P	8	32	4	3.2	-	-	1x3	759	1804	24
BSHR01605-3		5	3.175	32.5	M26x1.5P	12	42	19.25	3	-	-	1x3	1077	2289	25
BSHR01610-2		10	3.175	32	M26x1.5P	12	50	3	4	3	M4	1x2	779	1601	14
BSHR02005-3	20	5	3.175	38	M35x1.5P	15	45	20.3	3	-	-	1x3	1211	2906	30
BSHR02505-4	25	5	3.175	43	M40x1.5P	19	69	32.11	3	8	M6	1x4	1724	4904	37
BSHR02510-4		10	4.762	43	M40x1.5P	19	84	8	6	8	M6	1x4	2954	7295	41

※Standard ball nut from Ø8-Ø16 is assembled without wiper.



PRECISION BALL SCREWS

WWW.NIPPONKODOBEARINGS.CO.JP

